



Transport Canada
Safety and Security

Transports Canada
Sécurité et sûreté

Road Safety

Sécurité routière

Standards and Regulations Division

TEST METHOD 301.2 CNG Fuel System Integrity

Revised: February 28, 2004
Issued: May 20, 1994

Motor Vehicle Standards and Research Branch
Road Safety and Motor Vehicle Regulation Directorate
TRANSPORT CANADA
Ottawa, Ontario
K1A 0N5

Table of Contents

1. Introduction	1
2. Definition	1
3. Test Procedure	2
3.1 Applicability	2
3.2 General Requirements	2
3.3 Vehicle Loading	2
3.4 CNG Spillage	3
3.5 ATDs	4
3.6 Lateral-Moving Barrier Crash Test	4
3.7 Rear-Moving Barrier Crash Test	5
3.8 Moving Contoured Barrier Crash Test	5
Figure 1: Common Carriage for Moving Barriers	7
Figure 2: Common Carriage with Contoured Barrier Face Attached	8

1. Introduction

Test Method 301.2 — CNG Fuel Integrity (February 28, 2004) is to be used for demonstrating compliance with the requirements of section 301.2 of Schedule IV to the *Motor Vehicle Safety Regulations*.

(Original signed by)

Director, Standards Research and Development
for the Minister of Transport
Ottawa, Ontario

2. Definition

“ATD” means the 50th percentile male anthropomorphic test device as described in subpart B or subpart E, of part 572, title 49, of the *Code of Federal Regulations* of the United States.

3. Test Procedure

3.1 *Applicability*

The following procedure applies in determining compliance with section 301.2 of Schedule IV to the *Motor Vehicle Safety Regulations*.

3.2 *General Requirements*

- 3.2.1 Where a range of conditions is specified, the vehicle shall be capable of meeting the requirements at all points within the range.
- 3.2.2 A vehicle that has been subjected to a single barrier crash test need not be subjected to further testing.
- 3.2.3 The parking brake shall be disengaged and the transmission shall be in neutral. However, for paragraph 301.2(1)(b) of the Regulations, the parking brake shall be set.
- 3.2.4 The tires shall be inflated to the manufacturer's specifications.

3.3 *Vehicle Loading*

The vehicle, including test devices and instrumentation, shall be loaded to its unloaded vehicle mass, except for its fuel system, which shall be loaded as specified in paragraph 3.4.1 of this test method, in addition to the loading requirements of paragraphs 3.3.1, 3.3.2 and 3.3.4.

- 3.3.1 For a **passenger car**, the following shall be added:
 - (a) the vehicle rated cargo and luggage capacity mass, secured in the luggage area, and
 - (b) the appropriate number of test ATDs specified in subsection 3.5 of this test method, restrained only by the means that are installed in the vehicle for protection at the relevant seating positions.
- 3.3.2 For a **multipurpose passenger vehicle, truck, or bus with a GVWR of 4 536 kg or less**, the following shall be added:
 - (a) the appropriate number of ATDs specified in subsection 3.5 of this test method, restrained only by the means that are installed in the vehicle for protection at the relevant seating positions,
 - (b) the vehicle rated cargo and luggage capacity or 136 kg, whichever is less, secured to the vehicle and distributed so that the mass on

each axle, as measured at the tire-ground interface, is in proportion to its GAWR, and

- (c) if the mass on any axle exceeds the axle's proportional share of the test mass when the vehicle is loaded to the unloaded vehicle mass plus dummy mass, the remaining mass shall be placed so that the mass on that axle remains the same.

- 3.3.3 For the purposes of paragraph 3.3.2, the unloaded vehicle mass does not include the mass of **work performing accessories**.
- 3.3.4 **A school bus with a GVWR greater than 4 536 kg** shall be loaded to its unloaded vehicle mass plus an unsecured mass of 55 kg at every designated seating position.
- 3.3.5 **A multipurpose passenger vehicle, truck, or bus, other than a school bus, with a GVWR greater than 4 536 kg** shall be loaded to its unloaded vehicle mass.

3.4 CNG Spillage

CNG spillage shall be determined by measuring fuel system pressure.

- 3.4.1 The high-pressure portion of the fuel system shall be pressurized with nitrogen, which, when its temperature is stabilized at 21°C, shall have a pressure of 20 680 kPa or the maximum operating pressure, as specified by the vehicle manufacturer, that the fuel system is designed for, whichever is the higher.
- 3.4.2 The measured change in fuel system pressure shall be appropriately adjusted to compensate for changes in atmospheric conditions occurring during the test. The adjusted value shall be compared with the stipulated limit value.
- 3.4.3 All fuel system manual shutoff valves shall be in the open position, to simulate the engine running, at the time of the barrier crash.
- 3.4.4 If the vehicle has any fuel system electric shutoff valves that are normally open when the electrical system is activated, they shall be open at the time of the barrier crash and shall be set to close on impact.
- 3.4.5 If any electric shutoff valves prevent sensing of the pressure in the high-pressure portion of the fuel system by the pressure transducer when closed, they must be open for both the pre-test pressure measurement and after the vehicle ceases motion from the impact. All such electric shutoff valves shall be open for a period of one minute

prior to completing the pre-test fuel system pressure measurement and for 60 minutes after the vehicle ceases motion from the impact.

- 3.4.6 The pressure measurement shall be made using a location on the high-pressure portion of the fuel system that is in accordance with the vehicle manufacturer's recommendation.

3.5 ATDs

ATDs shall be installed in accordance to the following requirements:

- 3.5.1 For the frontal barrier crash test, at every front outboard designated seating position and at any other position for which the protection system is required to be tested under section 208 of Schedule IV to the Regulations.
- 3.5.2 For the rear-moving barrier crash test, at every front outboard designated seating positions.
- 3.5.3 For the lateral moving barrier crash test, at every front outboard designated seating positions.

3.6 Lateral-Moving Barrier Crash Test

The following additional conditions shall apply to the lateral moving barrier crash test:

- 3.6.1 The moving barrier, including the impact surface, supporting structure and carriage, shall have a mass of 1 814 kg.
- 3.6.2 The impact surface of the barrier shall be a vertical, rigid, flat rectangle 1 981 mm wide and 1 524 mm high, perpendicular to its direction of movement with its lower edge horizontal and 127 mm above the ground surface.
- 3.6.3 During the entire impact sequence, the barrier shall undergo no significant amount of dynamic or static deformation and shall absorb no significant portion of the energy resulting from the impact, except for energy that results in translational rebound movement of the barrier.
- 3.6.4 During the entire impact sequence, the barrier shall be guided so that it travels in a straight line, with no significant lateral, vertical or rotational movement.
- 3.6.5 The concrete surface upon which the vehicle is to be tested shall be level, rigid and of uniform construction, with a skid number of 75 when measured in accordance with the American Society for Testing

and Materials Method E-274-90 at 64 km/h omitting water delivery as specified in subsection 4.7 of that method.

- 3.6.6 The barrier and the test vehicle shall be positioned such that at impact:
- (a) the vehicle is at rest in its normal attitude,
 - (b) the barrier is travelling in a direction perpendicular to the longitudinal axis of the vehicle at 32 km/h, and
 - (c) a vertical plane through the geometric centre of the barrier impact surface and perpendicular to that surface passes through the driver's seating reference point in the tested vehicle.

3.7 Rear-Moving Barrier Crash Test

The rear-moving barrier additional test conditions shall be those specified in subsection 3.6, except for the conditions of paragraph 3.6.6, which shall be replaced by the following:

The barrier and test vehicle shall be positioned such that at impact:

- (a) the vehicle is at rest in its normal attitude,
- (b) the barrier is travelling at 48 km/h with its face perpendicular to the longitudinal centreline of the vehicle, and
- (c) a vertical plane through the geometric centre of the barrier impact surface and perpendicular to that surface coincides with the longitudinal centreline of the vehicle.

3.8 Moving Contoured Barrier Crash Test

The following conditions shall apply to the moving contoured barrier crash test:

- 3.8.1 The moving contoured barrier, mounted on a carriage as specified in Figure 1, shall be of rigid construction and symmetrical about a vertical longitudinal plane. The contoured impact surface, measuring 629 mm high by 1 981 mm wide, shall conform to the dimensions shown in Figure 2 and be attached to the carriage as shown in that figure. The ground clearance to the lower edge of the impact surface shall be 133 ± 13 mm and the wheelbase shall be $3\,048 \pm 50$ mm.
- 3.8.2 The complete moving contoured barrier, including the impact surface, supporting structure and carriage, shall have a mass of $1\,814 \pm 23$ kg with the mass distributed such that 408 ± 11 kg is at each rear wheel and 499 ± 11 kg is at each front wheel. The centre of gravity is located

1 372 ± 38 mm rearward of the front wheel axis, in the vertical longitudinal plane of symmetry, 401 ± 13 mm above the ground.

- 3.8.3 The moving contoured barrier shall have a solid non-steerable front axle and fixed rear axle attached directly to the frame rails with no spring or other type of suspension system on any wheel. The moving barrier assembly shall be equipped with a braking device capable of stopping its motion.
- 3.8.4 The moving barrier assemblies shall be equipped with P205/75R15 pneumatic tires inflated to 200 ± 21 kPa, but until August 31, 2005, they may be equipped with G78-15 pneumatic tires with a tread width of 152 ± 25 mm, inflated to 164 kPa.
- 3.8.5 The concrete surface upon which the vehicle is to be tested shall be level, rigid and of uniform construction, with a skid number of 75 when measured in accordance with the American Society for Testing and Materials Method E-274-90 at 64 km/h omitting water delivery as specified in subsection 4.7 of that method.
- 3.8.6 The barrier assembly shall be released from the guidance mechanism immediately prior to impact with the vehicle.

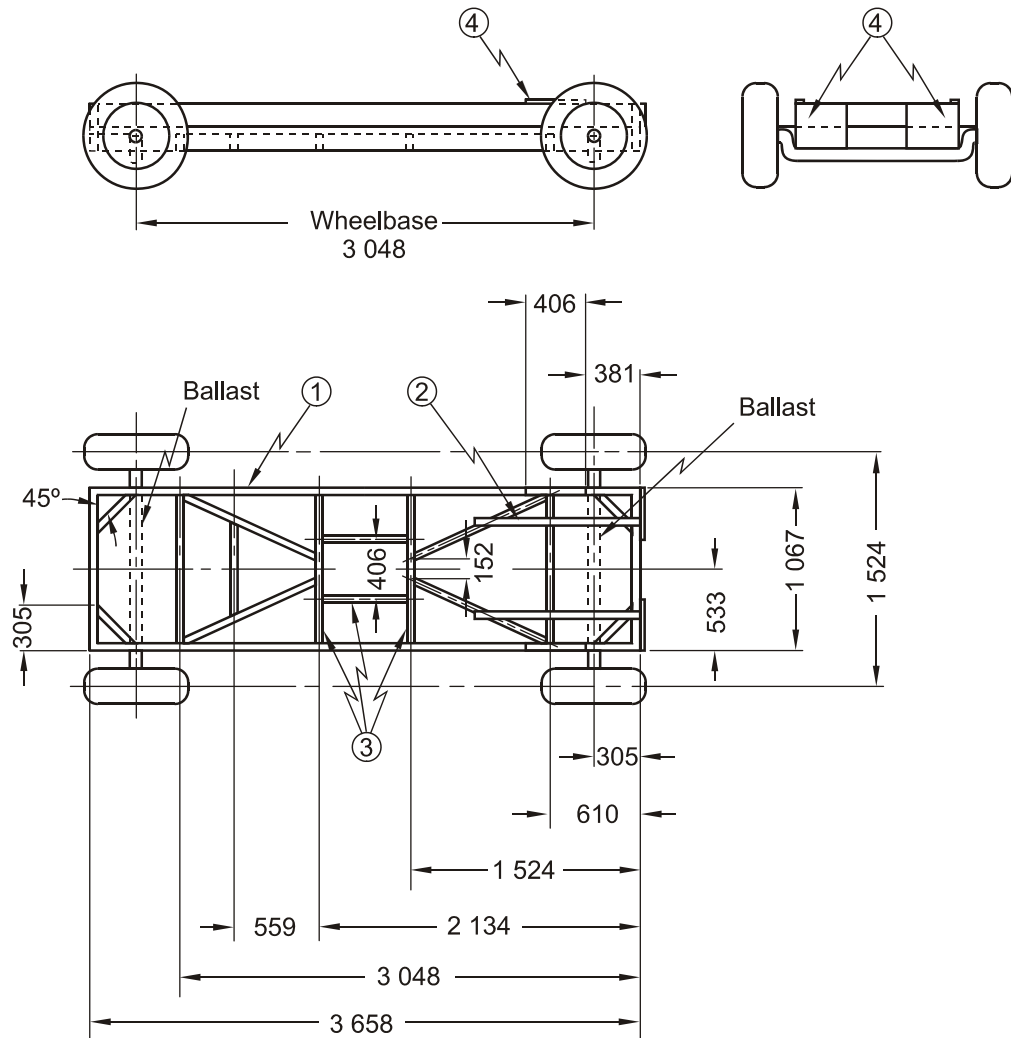

Notes:

- 1. Dimensions in mm
- 2. Drawing not to scale
- 3. Bullets:
 - 1 Outer frame 152 x 51 x 5 steel tubing, two pieces welded together for a height of 305
 - 2 Ballast tie downs
 - 3 All inner reinforcements and frame gussets of 102 x 51 x 5 steel tubing
 - 4 Reinforced areas for bolting on face plates

Figure 1: Common Carriage for Moving Barriers

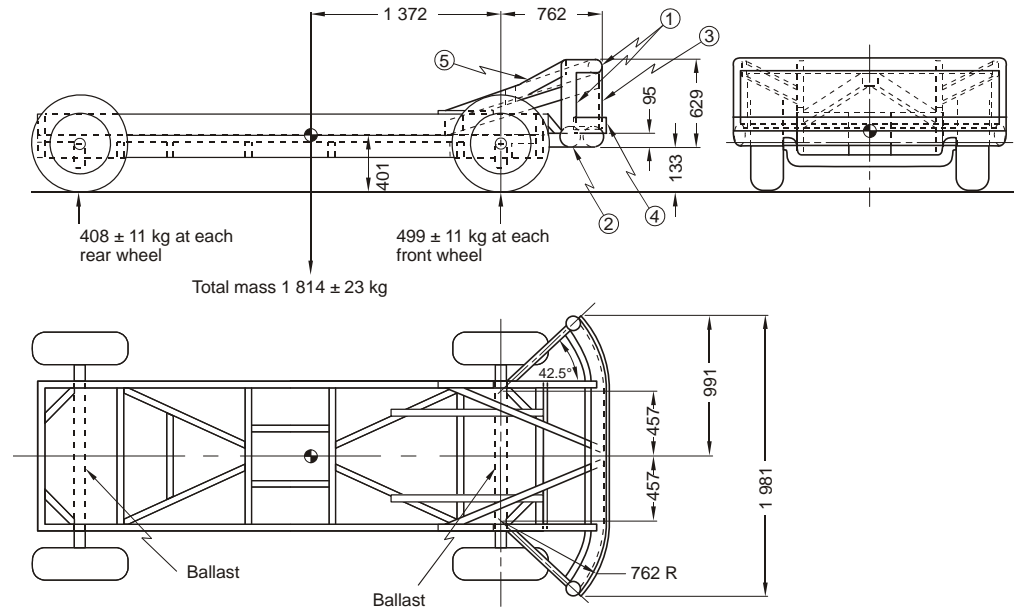

Notes:

1. Dimensions in mm

2. Not to scale

3. Bullets:

1 Upper frame 102 dia. x 6 wall steel tubing (three sides)

2 Lower frame 152 dia. x 13 wall steel tubing

3 Face plate 19 thick cold rolled steel

4 Leading edge 25 x 102 steel band, sharp edges broken

5 All inner reinforcements 102 x 51 x 5 steel tubing

Figure 2: Common Carriage with Contoured Barrier Face Attached