



Transport Canada
Safety and Security

Transports Canada
Sécurité et sûreté

Road Safety

Sécurité routière

Standards and Regulations Division

TECHNICAL STANDARDS DOCUMENT

No. 207, Revision 0

Anchorage of Seats

The text of this document is based on Federal Motor Vehicle Safety Standard No. 207, *Seating Systems*, as published in the U.S. *Code of Federal Regulations*, Title 49, Part 571, revised as of October 1, 2010.

Publication Date:	December 7, 2011
Effective Date:	December 7, 2011
Mandatory Compliance Date:	December 7, 2011

Standards Research and Development Branch
Road Safety and Motor Vehicle Regulation Directorate
TRANSPORT CANADA
Ottawa, Ontario
K1A 0N5

Technical Standards Document Number 207, Revision 0

Anchorage of Seats

(Ce document est aussi disponible en français.)

Introduction

As defined by section 12 of the *Motor Vehicle Safety Act*, a Technical Standards Document (TSD) is a document that reproduces an enactment of a foreign government (e.g. a Federal Motor Vehicle Safety Standard issued by the United States National Highway Traffic Safety Administration). According to the Act, the *Motor Vehicle Safety Regulations* may alter or override some provisions contained in a TSD or specify additional requirements; consequently, it is advisable to read a TSD in conjunction with the Act and its counterpart Regulation. As a guide, where the corresponding Regulation contains additional requirements, footnotes indicate the amending subsection number.

TSDs are revised from time to time in order to incorporate amendments made to the reference document, at which time a Notice of Revision is published in the *Canada Gazette*, Part I. All TSDs are assigned a revision number, with “Revision 0” designating the original version.

Identification of Changes

In order to facilitate the incorporation of a TSD, certain non-technical changes may be made to the foreign enactment. These may include the deletion of words, phrases, figures, or sections that do not apply under the Act or Regulations, the conversion of imperial to metric units, the deletion of superseded dates, and minor changes of an editorial nature. Additions are underlined, and provisions that do not apply are ~~stroked through~~. Where an entire section has been deleted, it is replaced by: “[CONTENT DELETED]”. Changes are also made where there is a reporting requirement or reference in the foreign enactment that does not apply in Canada. For example, the name and address of the United States Department of Transportation are replaced by those of the Department of Transport.

Effective Date and Mandatory Compliance Date

The effective date of a TSD is the date of publication of its incorporating regulation or of the notice of revision in the *Canada Gazette*, and the date as of which voluntary compliance is permitted. The mandatory compliance date is the date upon which compliance with the requirements of the TSD is obligatory. If the effective date and mandatory compliance date are different, manufacturers may follow the requirements that were in force before the effective date, or those of the TSD, until the mandatory compliance date.

In the case of an initial TSD, or when a TSD is revised and incorporated by reference by an amendment to the Regulations, the mandatory compliance date is as specified in the Regulations, and it may be the same as the effective date. When a TSD is revised with no

corresponding changes to the incorporating Regulations, the mandatory compliance date is six months after the effective date.

Official Version of Technical Standards Documents

Technical Standards Documents may be consulted electronically in both HTML and Portable Document Format (PDF) on the Department of Transport's Web site at <http://www.tc.gc.ca/eng/acts-regulations/regulations-crc-c1038.htm>. The PDF version is a replica of the TSD as published by the Department and is to be used for the purposes of legal interpretation and application. The HTML version is provided for information purposes only.

(Original signed by)

Director, Standards Research and Development
for the Minister of Transport,
Infrastructure and Communities
Ottawa, Ontario

TABLE OF CONTENTS**Technical Standards Document
Number 207, Revision 0****ANCHORAGE OF SEATS**

<i>Introduction</i>	<i>i</i>
<i>S1. Purpose and Scope</i>	<i>1</i>
<i>S2. Application</i>	<i>1</i>
<i>S3. Definitions</i>	<i>1</i>
<i>S4. Requirements</i>	<i>1</i>
<i>S4.1 Driver's seat</i>	<i>1</i>
<i>S4.2 General performance requirements</i>	<i>1</i>
<i>S4.3 Restraining device for hinged or folding seats or seat backs</i>	<i>2</i>
<i>S4.4 Labeling</i>	<i>3</i>
<i>S5. Test Procedures</i>	<i>3</i>

LIST OF FIGURES

Figure 1	5
Figure 2	6
Figure 3	6
Figure 4	7
Figure 5	7

**Technical Standards Document
Number 207, Revision 0**

ANCHORAGE OF SEATS

The text of this document is based on Federal Motor Vehicle Safety Standard No. 207, *Seating Systems*, as published in the U.S. *Code of Federal Regulations*, Title 49, Part 571, revised as of October 1, 2010.

S1. Purpose and Scope

This Technical Standards Document (TSD) ~~standard~~ establishes requirements for seats, their attachment assemblies, and their installation to minimize the possibility of their failure by forces acting on them as a result of vehicle impact.

S2. Application

[CONTENT DELETED] For applicability, see Schedule III and subsection 207(1) of Schedule IV to the *Motor Vehicle Safety Regulations*.

S3. Definitions

Occupant seat means a seat that provides at least one designated seating position.
(*siège d'occupant*)

Seat adjuster means the part of the seat that provides forward and rearward positioning of the seat bench and back, and/or rotation around a vertical axis, including any fixed portion, such as a seat track. In the case of a seat equipped with seat adjusters at different levels, the term means the uppermost seat adjuster. (*mécanisme de réglage du siège*)

S4. Requirements

S4.1 Driver's seat

Each vehicle shall have an occupant seat for the driver.

S4.2 General performance requirements

When tested in accordance with S5, each occupant seat shall withstand the following forces, in newtons, except for: a side-facing seat or a passenger seat on a bus; a passenger seat on a bus other than a school bus; a passenger seat on a school bus with a GVWR greater than 4,536 kilograms (10,000 pounds); and a passenger seat on a school bus with a GVWR less than or equal to 4,536 kg manufactured before October 21, 2011.

- (a) In any position to which it can be adjusted, 20 times the mass of the seat in kilograms multiplied by 9.8 m/s^2 applied in a forward longitudinal direction;
- (b) In any position to which it can be adjusted, 20 times the mass of the seat in kilograms multiplied by 9.8 m/s^2 applied in a rearward longitudinal direction;
- (c) For a seat belt assembly attached to the seat, the force specified in paragraph (a), if it is a forward-facing seat, or paragraph (b), if it is a rearward-facing seat, in each case applied simultaneously with the forces imposed on the seat by the seat belt assembly when it is loaded in accordance with subsections 210(7), (8) and (10) of Schedule IV of the *Motor Vehicle Safety Regulations* S4.2 of §571.210; and
- (d) In its rearmost position, a force that produces a 373 newton-meter moment about the seating reference point for each designated seating position that the seat provides, applied to the upper cross-member of the seat back or the upper seat back, in a rearward longitudinal direction for forward-facing seats and in a forward longitudinal direction for rearward-facing seats.

S4.2.1 Seat adjustment. Except for vertical movement of nonlocking suspension type occupant seats in trucks or buses, each seat shall remain in its adjusted position when tested in accordance with the test procedures specified in S5.

S4.3 Restraining device for hinged or folding seats or seat backs

Except for a passenger seat in a bus or a seat having a back that is adjustable only for the comfort of its occupants, a hinged or folding occupant seat or occupant seat back shall:

- (a) Be equipped with a self-locking device for restraining the hinged or folding seat or seat back, and
- (b) If there are any designated seating positions or auxiliary seating accommodations behind the seat, either immediately to the rear or to the sides, be equipped with a control for releasing that restraining device.

S4.3.1 Accessibility of release control. If there is a designated seating position immediately behind a seat equipped with a restraining device, the control for releasing the device shall be readily accessible to the occupant of the seat equipped with the device and, if access to the control is required in order to exit from the vehicle, to the occupant of the designated seating position immediately behind the seat.

S4.3.2 Performance of restraining device

S4.3.2.1 Static force

- (a) Once engaged, the restraining device for a forward-facing seat shall not release or fail when a forward longitudinal force, in newtons, equal to 20 times the mass of the hinged or folding portion of the seat in kilograms multiplied by 9.8 m/s^2 is applied through the center of gravity of that portion of the seat.

- (b) Once engaged, the restraining device for a rearward-facing seat shall not release or fail when a rearward longitudinal force, in newtons, equal to 8 times the mass of the hinged or folding portion of the seat in kilograms multiplied by 9.8 m/s^2 is applied through the center of gravity of that portion of the seat.

S4.3.2.2 Acceleration. Once engaged, the restraining device shall not release or fail when the device is subjected to an acceleration of 20 g in the longitudinal direction opposite to that in which the seat folds.

S4.4 Labeling

Seats not designated for occupancy while the vehicle is in motion shall be conspicuously labeled to that effect.¹

S5. Test Procedures

S5.1 Apply the forces specified in S4.2(a) and S4.2(b) as follows.

S5.1.1 For a seat whose seat back and seat bench are attached to the vehicle by the same attachments,

- (a) ~~For a seat whose seat back and seat bench are attached to the vehicle by the same attachments~~ And whose height is adjustable, the loads are applied when the seat is in its highest adjustment position in accordance with the procedure or procedures specified in S5.1.1(a)(1), ~~S5.1.1(a)(2)~~, or S5.1.1(a)(3), as appropriate.
- (1) For a seat whose center of gravity is in a horizontal plane that is above the seat adjuster, or that passes through any part of the adjuster, use, at the manufacturer's option, either S5.1.1(b) or, if physically possible, S5.1.1(c).
 - (2) ~~For a seat specified in S5.1.1(a)(1) for which it is not physically possible to follow the procedure in S5.1.1(c), use S5.1.1(b).~~
 - (3) For a seat whose center of gravity is in a horizontal plane that is below the seat adjuster, use S5.1.1(c).
 - (4) For all other seats ~~whose seat back and seat bench are attached to the vehicle by the same attachments~~, use S5.1.1(b).
- (b) Secure a strut on each side of the seat from a point on the outside of the seat frame in the horizontal plane of the seat's center of gravity to a point on the frame as far forward as possible of the seat anchorages. Between the upper ends of the struts, attach a rigid cross-member in front of the seat back frame for rearward loading and behind the seat back frame for forward loading. Apply the force specified by S4.2(a) or S4.2(b) horizontally through the rigid cross-member as shown in Figure 1.

¹ Please see subsection 207(2) of the *Motor Vehicle Safety Regulations (MVSR)* for an additional requirement.

- (c) Find “cg₁,” the center of gravity of the portion of the seat that is above the lowest surface of the seat adjuster. On each side of the seat, secure a strut from a point on the outside of the seat frame in the horizontal plane of cg₁ to a point on the frame as far forward as possible of the seat adjusted position. Between the upper ends of the struts, attach a rigid cross-member in front of the seat back frame for rearward loading and behind the seat back frame for forward loading. Find “cg₂,” the center of gravity of the portion of the seat that is below the seat adjuster. Apply a force horizontally through cg₁ equal to 20 times the weight of the portion of the seat represented by cg₁, and simultaneously apply a force horizontally through cg₂ equal to 20 times the weight of the portion of the seat represented by cg₂.

S5.1.2 If the seat back and the seat bench are attached to the vehicle by different attachments, attach to each component a fixture capable of transmitting a force to that component. Apply forces, in newtons, equal to 20 times the mass of the seat back in kilograms multiplied by 9.8 m/s² horizontally through the center of gravity of the seat back, as shown in Figure 2, and apply forces, in newtons, equal to 20 times the mass of the seat bench in kilograms multiplied by 9.8 m/s² horizontally through the center of gravity of the seat bench, as shown in Figure 3.

S5.2 Develop the moment specified in S4.2(d), as shown in Figure 4.

S5.3 Apply the forces specified in S4.3.2.1(a) and (b) to a hinged or folding seat, as shown in Figure 1, and to a hinged or folding seat back, as shown in Figure 5.

S5.4 Determine the center of gravity of a seat or seat component with all cushions and upholstery in place and with the head restraint in its fully extended design position.

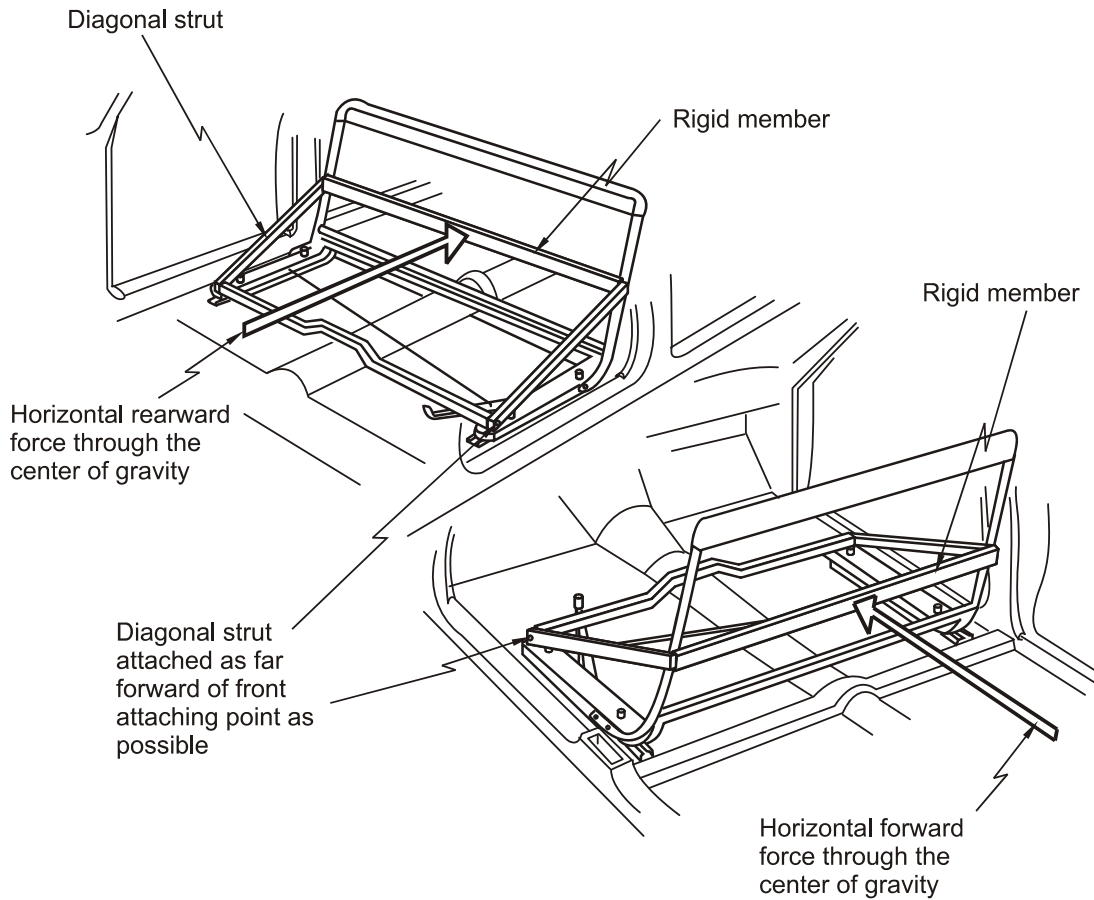

Figure 1

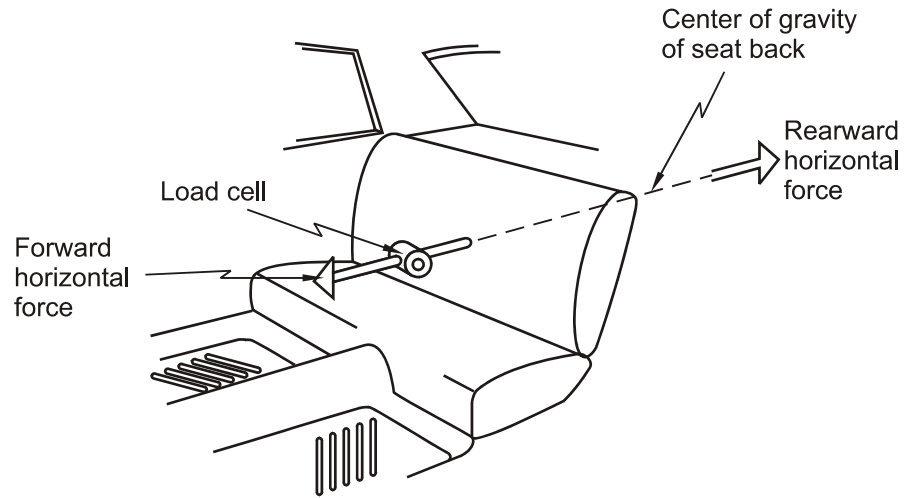

Figure 2

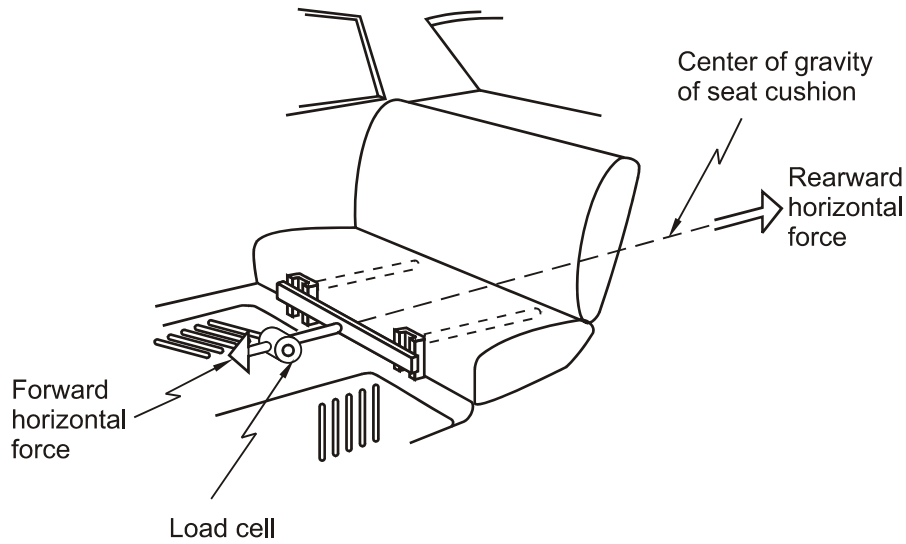
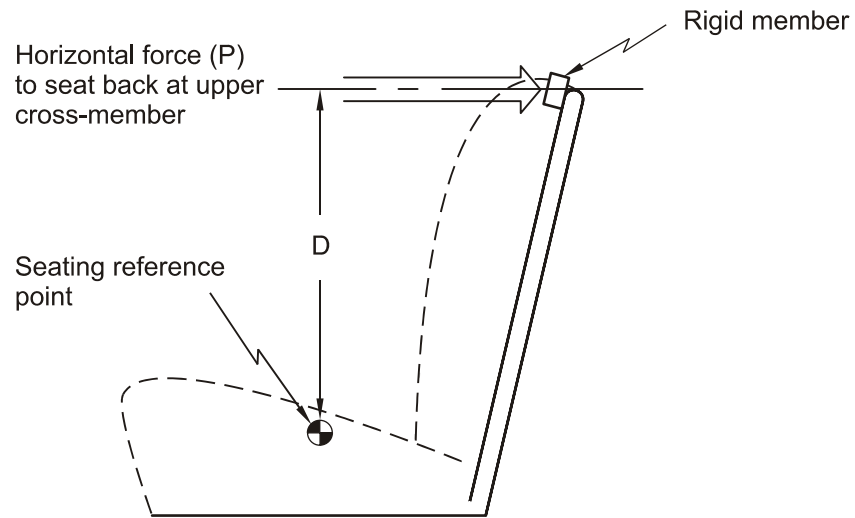

Figure 3



Note:
Moment ($P \times D$) is computed about the seating reference point.

Figure 4

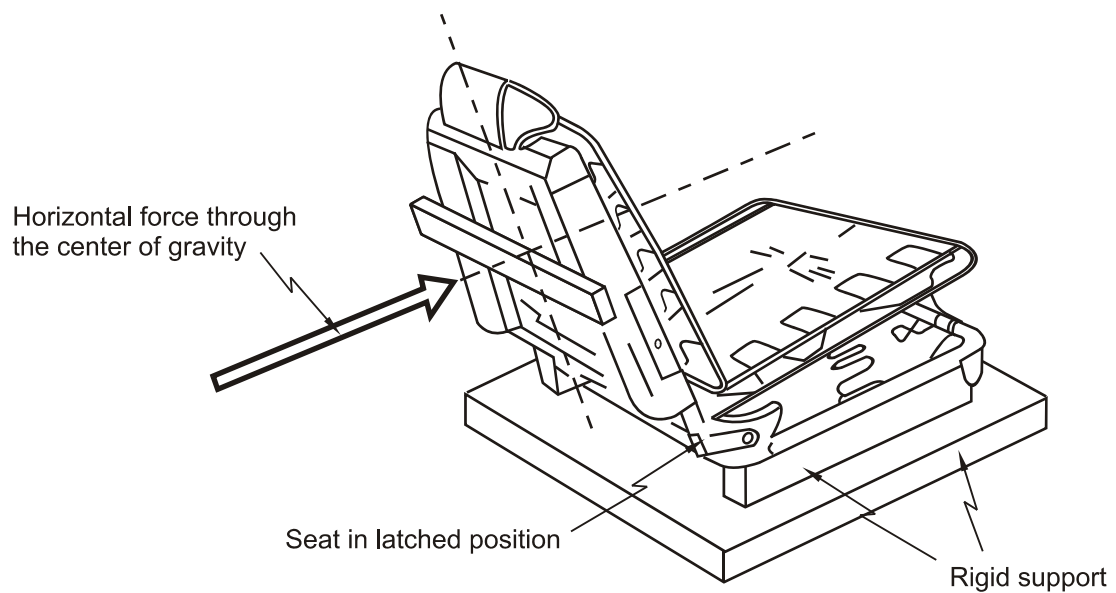

Figure 5