



Transport
Canada

Transports
Canada



TP 14371E
(2012-2)

Aeronautical Information Manual

Effective 0901Z, October 18, 2012, to 0901Z, April 4, 2013

TC-1004755



Canada 

1. Other related TC Publications:
TP 12916 *Civil Aviation Safety Inspector Toolkit*

2. Previous Edition:
TP 14371E (2012-1)

Printed in Canada

3. Please direct your comments, orders and inquiries to:

The Order Desk
Multimedia Products and Services
Transport Canada (AARA-MPS)
2655 Lancaster Road, Unit 100
Ottawa Ontario
K1B 4L5
Telephone: 1-888-830-4911 (in North America)
613-991-4071 (international)
Fax: 613-991-1653
E-mail: mps@tc.gc.ca

For general Civil Aviation inquiries please contact:

Civil Aviation Communications Centre (AARC)
Transport Canada
Place de Ville
330 Sparks Street
Ottawa, ON K1A 0N8
Telephone: 1-800-305-2059
Fax: 613-957-4208
E-mail: services@tc.gc.ca

4. © Her Majesty the Queen in Right of Canada, as represented by the Minister of Transport 2012

All rights reserved. No part of this publication may be reproduced, stored in a retrieval system, or transmitted, in any form or by any means, electronic, mechanical, photocopying, recording, or otherwise, without prior written permission of the Department of Transport, Canada. Please contact the Civil Aviation Communications Centre at 1 800 305-2059 (EST) for assistance.

The information in this publication is to be considered solely as a guide and should not be quoted as or considered to be a legal authority. It may become obsolete in whole or in part at any time without notice.

5. ISSN: 1715-7382
TP 14371E
(02/2012)
TC-1004755

6. Publication Mail agreement number 40063845



Transport
Canada

Transports
Canada

TP 14371E

Transport Canada

Aeronautical Information Manual

(TC AIM)

Canada[!]

TRANSPORT CANADA AERONAUTICAL INFORMATION MANUAL (TC AIM)

EXPLANATION OF CHANGES EFFECTIVE—OCTOBER 18, 2012

GEN

- (1) GEN 1.1.4
This section was updated.
- (2) GEN 4.0
This section was updated.
- (3) GEN 5.1
This section was updated.
- (4) GEN 5.2
This section was updated.

COM

- (1) COM 3.15.1
The term AIC 27/05 in the third paragraph was replaced with AIC 16/08.
The term AIC 2/00 in the fourth paragraph was replaced with AIC 15/08.
- (2) COM 3.15.11
The term AIC 2/00 in the first and second paragraphs was replaced with AIC 15/08.
- (3) COM 6.2.3
This section was updated.

MET

- MET
- (1) MET 1.1.3
Subparagraphs (a) and (b) were updated.
 - (2) MET 1.1.5
The second paragraph was updated.
 - (3) MET 1.2.5
This section was updated.
 - (4) MET 1.4.1
This section was updated.
 - (5) MET 3.3.5
The black and white graphic was replaced with a colour graphic.
 - (6) MET 3.3.8
The black and white graphic was replaced with a colour graphic.
 - (7) MET 3.3.11
The black and white graphics in this section were replaced with colour graphics.

- (8) MET 3.3.12
This section was updated and the black and white graphics were replaced with colour graphics.
New text and colour graphics were added to subparagraphs (b), (c) and (d).
- (9) MET 3.6
The acronym “VGSS” was added to this section.
- (10) MET 3.9.4
The first paragraph was updated.
- (11) MET 3.13
A new subparagraph (m) and a colour graphic were added to this section.
- (12) MET 3.15.1
A new paragraph was added at the end of this section. Subparagraph (e) was updated.
- (13) MET 3.15.3
This section was updated.
- (14) MET 3.15.4
Subparagraph (f) was updated.
- (15) MET 3.15.6.1
This section was updated.
- (16) MET 3.19
The black and white graphic was replaced with a colour graphic.

RAC

- (1) RAC 1.1.1
Subparagraph (h) was deleted and subparagraph (i) was updated.
- (2) RAC 1.1.5
The paragraph was updated in the French version.
- (3) RAC 2.7.1
New subparagraph (c) and two new graphics were added.
- (4) RAC 3.6.3
The second paragraph was deleted. The third and fourth paragraphs were updated.
- (5) RAC 3.15
This section was updated.
- (6) RAC 3.15.2
The terms “Canadian Flight Supplement” and “ADCUS” were deleted from this section.

(7) RAC 3.16

This section was updated.

(8) RAC 3.16.8

The term “ADCUS” was deleted from the last paragraph.

(9) RAC 4.4.3

Two new paragraphs were added at the end of this section.

(10) RAC 6.3.2.2

The third last paragraph was updated in the English version.

(11) RAC 9.2

The paragraph was deleted and four new paragraphs were added.

(12) RAC 9.2.4

A new section entitled “Minimum Sector Altitude (MSA)” was added.

(13) RAC 9.2.5

A new section entitled “Terminal Arrival Area (TAA)”, and a graphic entitled “Basic “T” Approach with TAA Depiction” was added.

(14) RAC 10.5

The first paragraph in the French edition was modified to correspond to the English edition.

(15) RAC 11.6.1

The third paragraph in subparagraph (f) was updated and a new paragraph was added.

(16) RAC 12.4.4

This section was deleted and replaced with a new section and table.

(17) RAC 12.5.5

This section was deleted and replaced with a new section.

(18) RAC 12.6.4

This section was deleted and replaced with a new section.

(19) RAC 12.7.3.5

This section was updated.

(20) RAC 12.17

“Reduced Vertical Separation Minimum” was added to the title.

(21) RAC 12.17.1

This section was updated.

FAL

(1) FAL 2.2.1

Prince George was added to the list of Regular-use aerodromes.

(2) FAL 2.3.2

This section was updated.

MAP

(1) MAP 2.1

The term “Ottawa” was added to the fourth paragraph.

(2) MAP 5.6

This section was updated.

AIR

(1) AIR 1.6.

The acronym “CRFI” was added to the title.

(2) AIR 1.6.1

This section was updated.

(3) AIR 1.6.2

This section was updated.

(4) AIR 1.6.3

This section was updated.

(5) AIR 1.6.4

This section was updated.

(6) AIR 1.6.5

This section was updated.

(7) AIR 1.6.6

This section was updated.

(8) AIR 1.8

The black and white graphics for “Marshalling Signals Diagram” were replaced with colour graphics.

(9) AIR 2.3

The black and white graphic for “Carburetor Icing” was replaced with a colour graphic.

(10) AIR 2.9

The black and white graphic for “Wake Turbulence” was replaced with a colour graphic.

(11) AIR 4.7

This section was updated.

(12) AIR 4.7.1

A new section was added.

(13) AIR 4.8

This section was updated.

(14) AIR 4.9

This section was updated.

(15) AIR 4.10

This section was updated.

(16) AIR 4.13

A new table was added and updated.

Table of Contents

GEN – GENERAL 1

- 1.0 GENERAL INFORMATION1**
- 1.1 **Aeronautical Information1**
 - 1.1.1 Aeronautical Authority1
 - 1.1.2 AIS2
 - 1.1.3 Aeronautical Information Publications2
 - 1.1.4 TC AIM Publication Information.....3
 - 1.1.5 NOTAM3
 - 1.1.6 Aerodromes.....3
- 1.2 **Summary of National Regulations3**
- 1.3 **Differences with ICAO Standards, Recommended Practices and Procedures3**
 - 1.3.1 ICAO’s Procedures for Air Navigation Services—Aircraft Operations (PANS OPS).....3
- 1.4 **Abbreviations, Acronyms and Initialisms4**
- 1.5 **Units of Measurement.....4**
 - 1.5.1 Other Units4
 - 1.5.2 Geographic Reference.....4
- 1.6 **Time System.....4**
 - 1.6.1 Date-Time Group4
 - 1.6.2 Morning and Evening Twilight Charts.....4
 - 1.6.3 Time Zone6
- 1.7 **Nationality and Registration Marks6**
- 1.8 **Special Equipment to be Carried on Board Aircraft6**
- 1.9 **Miscellaneous Information6**
 - 1.9.1 V Speeds6
 - 1.9.2 Conversion Tables7
 - 1.9.3 RVR Comparative Scale–Feet to Metres8
- 2.0 SAFETY8**
- 2.1 **Aviation Occupational Health and Safety Program8**
 - 2.1.1 General8
 - 2.1.2 Refusal to Work in Dangerous Situations8
 - 2.1.3 Civil Aviation Safety Inspectors — Occupational Health and Safety (CASI-OHS)9
 - 2.1.4 Web Site9
- 2.2 **System Safety National Program9**
 - 2.2.1 General9
 - 2.2.2 Safety Intelligence10
 - 2.2.3 Minister’s Observer and Technical Advisor Programs10
 - 2.2.4 Safety Communications and Partnerships10
- 3.0 TRANSPORTATION SAFETY BOARD OF CANADA11**
- 3.1 **Aviation Safety Investigation11**
- 3.2 **Definitions11**
- 3.3 **Reporting an Aviation Occurrence12**
 - 3.3.112
 - 3.3.212
 - 3.3.312
 - 3.3.413
 - 3.3.513
- 3.4 **Protection of Occurrence Sites, Aircraft, Components and Documentation13**
 - 3.4.113
 - 3.4.213
 - 3.4.313
- 3.5 **SECURITAS Program14**
- 3.6 **Offices of the TSB.....14**
- 4.0 INDEX OF KEYWORDS15**
- 5.0 MISCELLANEOUS32**
 - 5.1 Glossary of Aeronautical Terms.....32
 - 5.2 Abbreviations and Acronyms41
 - 5.3 Legislation Index44

6.0 CIVIL AVIATION CONTINGENCY OPERATIONS (CACO)	46
6.1 Introduction	46
6.2 Headquarters Operations	46
6.3 Civil Aviation Accident, Occurrence, or Incident Reporting	46

AGA - AERODROMES **47**

1.0 GENERAL INFORMATION	47
1.1 General	47
1.1.1 Aerodrome Authority	47
1.1.2 ICAO Documents	47
1.1.3 Differences with ICAO Standards, Recommended Practices and Procedures	47
1.1.4 Canadian Runway Friction Index	47
1.1.5 Contaminated Runway Operations	47
1.1.6 Bird Hazard	47
1.2 International Airports	48
1.2.1 ICAO Definitions	48
1.3 Aerodrome Directory	48
1.4 Aeronautical Ground Lights	48
2.0 AERODROMES AND AIRPORTS	48
2.1 General	48
2.2 Use of Aerodromes and Airports	49
2.3 Airport Certification	49
2.3.1 General	49
2.3.2 Applicability of Airport Certification	49
2.3.3 Transport Canada Responsibilities	49
2.3.4 Operator Responsibilities	49
2.3.5 Airport Certification Process	50
2.3.6 Regulatory References for Airport and Heliport Certification	50
2.4 Airport Certificate	50
2.4.1 Issue	50
2.4.2 Airport Certificate Validity and Amendments	50
3.0 RUNWAY CHARACTERISTICS	50
3.1 Runway Length and Width	50
3.2 Graded Area	51
3.3 Displaced Runway Threshold	51
3.4 Turnaround Bay	51
3.5 Pre-Threshold Area	51
3.6 Stopway	51
3.7 Clearway	51
3.8 Declared Distances	52
3.9 Rapid-Exit Taxiways	52
3.10 Runway and Taxiway Bearing Strength	52
3.10.1 Pavement Load Rating Charts	52
3.11 Heliports	52
3.11.1 FATO	52
3.11.2 Heliport Classification	52
3.11.3 Heliport Operational Limitations	53
4.0 OBSTACLE RESTRICTIONS	53
4.1 General	53
4.2 Obstacle Limitation Surfaces	53
4.2.1 General	53
4.2.2 Heliports	53
4.3 Airport Zoning Regulations	53
4.3.1 General	53
4.3.2 Airports Where Zoning Regulations Are in Effect	54

5.0	MARKERS, MARKING, SIGNS AND INDICATORS	54
5.1	Aircraft Takeoff or Landing Area Boundary Markers	54
5.2	Air Taxiway Edge Markers.....	54
5.3	Seaplane Dock Markers	54
5.4	Runway Markings	54
5.4.1	Displaced Threshold Markings	55
5.4.2	Stopways.....	55
5.4.3	Taxiway Exit and Holding Markings.....	55
5.5	Heliports.....	56
5.5.1	Heliport TLOF Marking	56
5.5.2	Safety Area Markers	56
5.5.3	Heliport Identification Markings	56
5.5.4	FATO Marking.....	56
5.5.5	Helicopter Parking Position Marking.....	56
5.5.6	Approach and Take-Off Direction Indicator Markings	56
5.6	Closed Markings	56
5.7	Unserviceable Area Markings	57
5.8	Airside Guidance Signs	57
5.8.1	General	57
5.8.2	Operational Guidance Signs	57
5.8.3	Mandatory Instruction Signs	58
5.8.4	Illumination of Airside Guidance Signs	59
5.9	Wind Direction Indicators	59
6.0	OBSTRUCTION MARKING AND LIGHTING	59
6.1	General	59
6.2	Standards	59
6.3	Requirements for an Aeronautical Evaluation	60
6.4	Marking	60
6.5	Lighting	60
6.6	Appurtenances	61
6.7	Suspended Cable Span Markings	61
6.8	Aircraft Detection Systems	62
7.0	AERODROME LIGHTING	62
7.1	General	62
7.2	Aerodrome Beacon.....	63
7.3	Minimum Night Lighting Requirements at Aerodromes.....	63
7.4	Unserviceable Area Lighting	63
7.5	Approach Lighting	63
7.5.1	Non-Precision Approach Runways	63
7.5.2	Precision Approach Runways	64
7.6	Approach Slope Indicator Systems	64
7.6.1	General	64
7.6.1.1	64
7.6.1.2	64
7.6.1.3	64
7.6.1.4	65
7.6.1.5	65
7.6.1.6	65
7.6.2	Visual Approach Slope Indicator Systems (VASIS)	65
7.6.2.1	2-BAR VASI (V1 and V2)	65
7.6.2.2	3-BAR VASI (V3).....	65
7.6.2.3	Precision Approach Path Indicator (PAPI)	65
7.6.3	Categories According to EWH in the Approach Configuration	66
7.6.3.1	66
7.6.3.2	66
7.6.3.3	66
7.6.3.4	66
7.6.4	Knowing your EWH	66
7.6.4.1	66
7.7	Runway Identification Lights.....	66
7.7.1	Runway Identification Lights (RILS).....	66
7.7.2	Visual Alignment Guidance System (VAGS)	67

7.8	Runway Lighting	67
7.8.1	Runway Edge Lights	67
7.8.2	Runway Threshold End Lights	67
7.9	Displaced Runway Threshold Lighting	67
7.10	Runway Centreline Lighting	67
7.11	Runway Touchdown Zone Lighting	67
7.12	Rapid-Exit Taxiway Lighting	68
7.13	Taxiway Lighting	68
7.14	Stop Bars	68
7.15	Runway Guard Lights	68
7.16	Heliport Lighting	68
7.16.1	FATO Lighting	69
7.16.2	Approach/Take-Off Direction Lights	69
7.17	Emergency Lighting	69
7.18	Aircraft Radio Control of Aerodrome Lighting (ARCAL)	69
7.19	Retroreflective Markers	70
8.0	AIRCRAFT RESCUE AND FIRE FIGHTING (ARFF)	70
8.1	General	70
8.2	ARFF Hours of Availability	70
8.3	Classification System	70
8.4	ARFF Standby Request	71
8.5	ARFF Discreet Communication	71
9.0	AIRCRAFT ARRESTING SYSTEMS	71
9.1	Engineered Material Arresting Systems (EMAS)	71
9.1.1	System Description	71
9.1.2	System Depiction	71
9.1.3	Pilot Considerations for Engagement	72
9.2	Military Aircraft Arresting Systems	72
9.2.1	Background	72
9.2.2	Markings	72
9.2.3	Operations	72
9.2.4	Damage Hazards	73
9.2.5	Information for Pilots	73

COM – COMMUNICATIONS 75

1.0	GENERAL INFORMATION	75
1.1	General	75
1.2	Responsible Authority	75
1.3	Provision of Services	75
1.3.1	NAV CANADA	75
1.3.2	Canadian Base Operators (CBO)	75
1.3.3	Other Telecommunication System Operators	75
2.0	LOCATION INDICATORS	75
2.1	General	75
3.0	RADIO NAVIGATION AIDS	75
3.1	General	75
3.1.1	Non-NAV CANADA Navigation Aids	75
3.1.2	Interference with Aircraft Navigational Equipment	76
3.2	Removal of Identification	76
3.3	Accuracy, Availability and Integrity of Navigation Aids	76
3.4	Pilot Reporting of Abnormal Operation of Navigation Aids	77
3.5	VHF Omnidirectional Range	77
3.5.1	VOR Receiver Checks	77
3.5.2	VOR Check Point	77
3.5.3	Airborne VOR Check	78
3.6	NDB	78
3.7	Distance Measuring Equipment	78
3.8	Tactical Air Navigation	78
3.9	VHF Omnidirectional Range and Tactical Air Navigation	78

3.10	VHF Direction Finding Equipment	79
3.11	Localizer	79
3.12	ILS	79
3.12.1	Caution—Use of ILS Localizers	79
3.12.2	Localizer	81
3.12.3	Glide Path.....	81
3.12.4	NDBs	82
3.12.5	ILS/DME, ILS/RNAV	82
3.12.6	ILS Categories	82
3.12.7	CAT II/III ILS.....	82
3.13	RADAR	82
3.14	Area Navigation.....	83
3.14.1	VOR/DME (RHO-THETA) System	83
3.14.2	DME-DME (RHO-RHO) System	83
3.14.3	LORAN-C System.....	83
3.15	Global Navigation Satellite System (GNSS).....	84
3.15.1	Satellite Navigation (SatNav).....	84
3.15.2	Navigation Performance Requirements.....	84
3.15.3	Global Positioning System (GPS).....	84
3.15.4	Augmentation Systems	85
3.15.4.1	Aircraft-Based Augmentation System (ABAS)	85
3.15.4.2	Satellite-Based Augmentation System (SBAS)	86
3.15.4.3	Ground-Based Augmentation System (GBAS)	87
3.15.5	IFR Approval to Use GNSS and WAAS in Domestic Airspace	87
3.15.5.1	Domestic En-Route and Terminal Operations	87
3.15.5.2	GNSS-Based RNAV Approach Procedures	88
3.15.5.2.1	RNAV Approaches with Lateral Guidance Only	88
3.15.5.2.2	GPS Overlay Approaches	89
3.15.5.2.3	Vertical Guidance on RNAV Approaches	89
3.15.5.2.4	RNAV Approaches with Vertical Guidance Based on BARO VNAV.....	89
3.15.5.2.5	RNAV Approaches with Vertical Guidance Based on WAAS	90
3.15.6	Flight Planning.....	90
3.15.6.1	GPS NOTAM.....	90
3.15.6.2	WAAS NOTAM.....	91
3.15.6.3	Negative W Notation.....	92
3.15.7	Flight Plan Equipment Suffixes.....	92
3.15.8	Avionics Databases	92
3.15.9	Use of GNSS in Lieu of Ground-based Aids.....	92
3.15.10	Replacement of DME or ADF by GNSS Avionics.....	92
3.15.11	NAT MNPS Operations.....	93
3.15.12	GPS and WAAS Approaches at Alternate Aerodromes	93
3.15.12.1	GNSS Approaches at Alternate Aerodromes – GPS (TSO C129/C129a) Avionics	93
3.15.12.2	GNSS Approaches at Alternate Aerodromes – WAAS Avionics	94
3.15.13	Next Generation GNSS.....	94
3.15.14	Required Navigation Performance (RNP) and SatNav	94
3.15.15	GNSS Vulnerability – Interference/Anomaly Reporting	94
3.15.16	Proper Use of GNSS	95
3.15.17	Communication, Navigation, Surveillance Implementation Team (CNS IT).....	95
3.15.18	GNSS User Comments.....	96
4.0	TIME SIGNALS.....	98
4.1	General	98
5.0	RADIO COMMUNICATIONS	98
5.1	General	98
5.2	Language.....	98
5.3	VHF Communication Frequencies– Channel Spacing.....	98
5.4	Use of Phonetics.....	99
5.5	Airways and Air Routes Designation.....	99
5.6	Distance Reporting	99
5.7	Use of Numbers	99
5.8	Call Signs	99
5.8.1	Civil Aircraft.....	99
5.8.2	Ground Stations	101
5.8.3	RCO.....	101
5.9	Standard Radio Telephony	101

5.10	Communications Checks	102
5.11	Emergency Communications	102
5.12	Monitoring of Emergency Frequency 121.5 MHz	103
5.13	VHF Frequency Allocations	103
5.13.1	Air Traffic Services.....	103
5.13.2	Soaring.....	103
5.13.3	Air-to-Air.....	103
5.14	Use of Frequency 5680 kHz	104
5.15	Phone Use During a Radio Communications Failure	104
6.0	AERONAUTICAL FIXED SERVICES – INTERNATIONAL FLIGHTS	104
6.1	AFS	104
6.1.1	Voice Systems.....	104
6.1.2	AFTN.....	104
6.2	International A/G Service	105
6.2.1	HF Aeromobile Operations in the NAT.....	105
6.2.2	HF Operations—Anchorage Arctic.....	105
6.2.3	VOLMET.....	105
6.3	Availability of SSB	105
6.4	SELCAL	106
6.5	Telecommunications and En Route Facilities Service Fees	106
6.6	Use of General Purpose VHF or SATCOM Voice in Lieu of International HF A/G Frequencies	106
6.6.1	NAT and Anchorage Arctic Regions—SATCOM Voice Use.....	106
6.6.2	NAT Region—VHF Coverage.....	106
6.6.3	Canadian Northern Airspace—SATCOM Voice Use.....	107
6.6.4	Canadian Northern Airspace—VHF Coverage.....	107
COM ANNEX A – RADIO COMMUNICATIONS		108
1.0	Canadian Aviation Regulations.....	108
COM ANNEX B – USE OF PORTABLE PASSENGER-OPERATED ELECTRONIC DEVICES ON BOARD AIRCRAFT		109
1.0	General.....	109
1.1	Portable Two-Way Radiocommunication Devices.....	110
2.0	Regulatory Requirement.....	110
3.0	Operating Procedures.....	110
3.1	Informing Passengers.....	110
3.2	Interference.....	112

MET – METEOROLOGY

113

1.0	GENERAL INFORMATION	113
1.1	General	113
1.1.1	Meteorological Responsibility.....	113
1.1.2	Meteorological Services Available.....	113
1.1.3	Aviation Weather Services.....	113
1.1.4	Weather Service Information.....	114
1.1.5	Weather Observing Systems and Procedures at Major Aerodromes.....	114
1.1.6	Pilot Reports.....	114
1.1.7	Applicable International Civil Aviation Organization (ICAO) and World Meteorological Organization (WMO) Documents.....	115
1.1.8	Differences from ICAO Annex 3.....	115
1.1.9	Pilot Responsibility.....	115
1.2	Meteorological Observation and Reports	115
1.2.1	Aeronautical Meteorological Stations and Offices.....	115
1.2.2	Type and Frequency of Observations.....	115
1.2.3	Flight Weather Documentation.....	116
1.2.4	Automated Weather Observation System.....	116
1.2.5	LWIS.....	116
1.2.6	Weather Services in Support of Approach UNICOM (AU).....	116
1.2.7	Runway Visibility Assessment (RVA).....	116
1.3	Meteorological Forecasts and Charts	117
1.3.1	Locations.....	117
1.3.2	Hours of Service and Telephone Numbers of FICs.....	117

1.3.3	World Area Forecast System (WAFS) Charts	117
1.3.4	Aerodrome Forecasts	117
1.3.5	Weather Information	117
1.3.6	Area Forecasts and AIRMET	117
1.3.7	Upper Level Wind and Temperature Forecasts	118
1.3.8	ATC Weather Assistance	118
1.3.9	Supplementary Information	118
1.4	VOLMET	118
1.4.1	General	118
2.0	PILOT REPORTS	119
2.1	General	119
2.2	Clear Air Turbulence	119
2.3	Wind Shear	119
2.4	Airframe Icing	119
2.5	Volcanic Ash	120
2.6	Pilot Estimation of Surface Wind	120
3.0	APPENDICES	122
3.1	Location of Canadian Weather Centres	122
3.2	Canadian Weather Information	122
3.2.1	Aviation Forecasts and Charts	122
3.2.2	Aviation Weather Reports	123
3.2.3	Weather Charts	123
3.3	Graphic Area Forecast (GFA)	124
3.3.1	General	124
3.3.2	Issue and Valid Times	124
3.3.3	Coverage Area	124
3.3.4	Units of Measure	124
3.3.5	Abbreviations and Symbols	124
3.3.6	Layout	124
3.3.7	Title Box	124
3.3.8	Legend Box	125
3.3.9	Comments Box	125
3.3.10	Weather Information	125
3.3.11	Clouds and Weather Chart	126
3.3.12	Icing, Turbulence and Freezing Level Chart	128
3.3.13	GFA Amendments	130
3.4	AIRMET	130
3.4.1	Definition	130
3.4.2	Criteria	130
3.4.3	Validity	130
3.5	Meteorological Reference Points Map	132
3.6	Abbreviations – Aviation Forecasts	134
3.7	Turbulence Reporting Criteria Table	137
3.8	Aerodrome Forecast Locations	138
3.9	Aerodrome Forecast – TAF	138
3.9.1	General	138
3.9.2	National Variations	139
3.9.3	Sample Message	139
3.9.4	Aerodrome Forecasts from AWOS Sites	142
3.10	Canadian Forecast Winds and Temperatures Aloft Network	143
3.11	Upper Level Wind and Temperature Forecasts (FD)	144
3.12	Upper Level Charts	144
3.13	Significant Weather Prognostic High-Level Charts (SIGWX HI LVL)	145
3.14	Significant Weather Prognostic Charts – CMC	147
3.15	Aviation Routine Weather Report - METAR	147
3.15.1	The METAR Code	147
3.15.2	National Variations	147
3.15.3	Sample Message	147
3.15.4	Aerodrome Special Meteorological Reports (SPECI)	151
3.15.5	Reports from Automated Weather Observation Systems (AWOS)	153
3.15.6	Other Automated Reports	156
3.15.6.1	LWIS	156
3.15.6.2	Voice Generator Module Reports	156

3.16	EC/DND Weather Radar Network	157
3.17	PIREP	157
3.18	SIGMET	158
3.19	Surface Weather Maps	158
3.20	Upper Level Charts – ANAL	159
3.21	Volcanic Ash Prognostic Charts	159

RAC – RULES OF THE AIR AND AIR TRAFFIC SERVICES 163

1.0 GENERAL INFORMATION163

1.1	AIR TRAFFIC SERVICES	163
1.1.1	ATC and Information Services	163
1.1.2	Flight Advisory and Information Services	164
1.1.2.1	A FIC provides:	164
1.1.2.2	An FSS provides:	164
1.1.2.3	FICs and FSSs may provide:.....	165
1.1.2.4	International Flight Service Station (IFSS)	166
1.1.3	RCOs and DRCOs	166
1.1.4	Arctic Radio	167
1.1.5	Military Flight Advisory Unit	167
1.2	Services Other Than Air Traffic Services	167
1.2.1	Universal Communications	167
1.2.2	Airport Radio/Community Aerodrome Radio Station	167
1.2.3	Private Advisory Stations (PAS)—Controlled Airports	168
1.2.4	Apron Advisory Service	168
1.3	ATIS	168
1.4	Use of Term “CAVOK”	169
1.5	Radar Service	169
1.5.1	General	169
1.5.2	Procedures	169
1.5.3	Radar Traffic Information	170
1.5.4	Radar Navigation Assistance to VFR Flights	170
1.5.5	Obstacle Clearance During Radar Vectors	171
1.5.6	Misuse of Radar Vectors	171
1.5.7	Canadian Forces Radar Assistance	171
1.5.8	The Use of Radar in the Provision of AAS and RAAS by FSSs	172
1.6	VDF Service.....	172
1.6.1	Purpose.....	172
1.6.2	Equipment Operation	172
1.6.3	Provision of Service	172
1.6.4	Procedures	172
1.7	ATC Clearances, Instructions and Information	173
1.8	Flight Priority	173
1.8.1	173	
1.8.2	Minimum Fuel Advisory	174
1.9	Transponder Operation	174
1.9.1	General	174
1.9.2	Transponder Requirements	175
1.9.3	IFR Operations in Other Low Level Airspace	175
1.9.4	VFR Operations	175
1.9.5	Phraseology	176
1.9.6	Emergencies	176
1.9.7	Communication Failure	176
1.9.8	Unlawful Interference (Hijack).....	176
1.10	Collision Avoidance—Right of Way (CARs)	176
1.11	Aerobatic Flight (CARs 602.27 and 602.28)	177
1.12	Pilot Reports	178
1.12.1	General	178
1.12.2	CIRVIS Reports – Vital Intelligence Sightings	178
1.12.3	Meteorite Reports	178
1.12.4	Fire Detection – Northern Areas	178
1.12.5	Pollution Reports	178
1.13	ATS Reports—Possible Contravention of the Canadian Aviation Regulations (CARs)	179
1.14	Conservation	179
1.14.1	Fur and Poultry Farms	179

1.14.2	Protection of Wildlife	179
1.14.3	Reindeer, Caribou, Moose and Muskoxen Conservation	180
1.14.4	Migratory Bird Protection	180
1.14.5	National, Provincial and Municipal Parks, Reserves and Refuges	180
1.15	Wildlife Hazards	181
1.15.1	Introduction.....	181
1.15.2	Airport Wildlife Management	181
1.15.3	Communication of Wildlife Hazards	182
1.15.4	Bird/Wildlife-Strike Reporting Procedures.....	182
2.0	AIRSPACE – REQUIREMENTS AND PROCEDURES.....	186
2.1	General.....	186
2.2	Canadian Domestic Airspace	186
2.2.1	Northern Domestic Airspace.....	186
2.3	High and Low Level Airspace.....	186
2.3.1	Cruising Altitudes and Cruising Flight Levels Appropriate to Aircraft Track	186
	General Provisions	186
2.4	Flight Information Regions.....	187
2.5	Controlled Airspace	187
2.5.1	Use of Controlled Airspace by VFR Flights	187
2.5.2	Aircraft Speed Limit Order	187
	Exceptions 187	
2.6	High Level Controlled Airspace.....	188
2.7	Low-Level Controlled Airspace	188
2.7.1	Low-Level Airways	188
2.7.2	Control Area Extensions	189
2.7.3	Control Zones	189
2.7.4	VFR Over-the-Top	191
2.7.5	Transition Areas	191
2.7.6	Terminal Control Areas	191
2.8	Airspace Classification	192
2.8.1	Class A Airspace.....	192
2.8.2	Class B Airspace	192
2.8.3	Class C Airspace	193
2.8.4	Class D Airspace	193
2.8.5	Class E Airspace	193
2.8.6	Class F Airspace	193
2.8.7	Class G Airspace	195
2.9	OTHER AIRSPACE DIVISIONS	196
2.9.1	Altitude Reservation	196
2.9.2	Temporary Flight Restrictions—Forest Fires	196
2.9.3	Flight Operations Over or in the Vicinity of Nuclear Power Plants	196
2.10	Altimeter Setting Region	196
2.11	Standard Pressure Region	196
2.12	Mountainous Regions	197
2.13	Emergency Communications and Security.....	198
3.0	FLIGHT PLANNING.....	198
3.1	General	198
3.2	Pilot Briefing Service	198
3.3	Aeronautical Information	199
3.4	DUATS	199
3.5	Weight and Balance Control	199
3.5.1	Definitions	199
3.5.2	Weight Control	200
3.5.3	Balance.....	201
3.5.4	Operational Requirements	201
3.5.5	Computerized Systems	201
3.5.6	Segmented Weights.....	201
3.5.6.1	Derivation of Segmented Weights	202
3.5.7	Computation of Passenger and Baggage Weights	202
3.5.8	Fuel and Oil Weights	204
3.6	Flight Plans and Flight Itineraries	205
3.6.1	When Required	205
3.6.2	Filing (CAR 602.75)	205

- 3.6.3 Flight Plan Requirements—Flights Between Canada and a Foreign State206
- 3.6.4 Opening a VFR Flight Plan or Flight Itinerary206
- 3.7 Changes To The Information In A Flight Plan Or Flight Itinerary206**
 - 3.7.1 VFR Flight Plan or Flight Itinerary206
 - 3.7.2 IFR Flight Plan or Flight Itinerary206
- 3.8 Composite Flight Plan Or Flight Itinerary—VFR And IFR206**
- 3.9 Defence VFR Flight Plans and Defence Flight Itineraries (CAR 602.145)207**
- 3.10 Intermediate Stops207**
 - 3.10.1 Consecutive IFR Flight Plans208
- 3.11 Cross Country Instrument Training Flights208**
- 3.12 Closing208**
 - 3.12.1 Arrival Report208
 - 3.12.2 Closing of a Flight Plan or Flight Itinerary Prior to Landing209
- 3.13 Fuel Requirements209**
 - 3.13.1 VFR Flight209
 - 3.13.2 IFR Flight209
- 3.14 Requirements for Alternate Aerodrome — IFR Flight210**
 - 3.14.1 Alternate Aerodrome Weather Minima Requirements210
- 3.15 Completion of Canadian Flight Plans and Flight Itineraries and ICAO Flight Plans211**
 - 3.15.1 General211
 - 3.15.2 Canadian211
 - 3.15.3 ICAO212
 - 3.15.4 Instructions for Completing the Form212
 - 3.15.4.1 General212
 - 3.15.4.2 Instructions for Insertion of ATS Data212
- 3.16 Contents of a Flight Plan and Flight Itinerary212**
 - 3.16.1 Item 7: Aircraft Identification (not exceeding seven alphanumeric characters and without hyphens or symbols)212
 - 3.16.2 Item 8: Flight Rules and Type of Flight213
 - 3.16.2.1 Flight Rules (one character) (Canadian and ICAO)213
 - 3.16.2.2 Type of Flight (up to two characters, as applicable)213
 - 3.16.3 Item 9: Number and Type of Aircraft and Wake Turbulence Category213
 - 3.16.3.1 Number of Aircraft (one or two characters)213
 - 3.16.3.2 Type of Aircraft (two to four characters).....213
 - 3.16.3.3 ICAO Wake Turbulence Category (one character)213
 - 3.16.4 Item 10: Equipment and Capabilities (Canadian and ICAO)213
 - 3.16.4.1 Radio Communication, Navigation and Approach Aid Equipment and Capabilities214
 - 3.16.4.2 Surveillance Equipment and Capabilities214
 - 3.16.5 Item13: Departure Aerodrome and Time215
 - 3.16.5.1 Departure Aerodrome (maximum four characters)215
 - 3.16.5.2 Time (maximum four characters)215
 - 3.16.6 Item 15: Cruising Speed, Altitude/Level and Route215
 - 3.16.6.1 Flights Along Designated ATS Routes:216
 - 3.16.6.2 Flights Outside Designated ATS Routes:216
 - 3.16.7 Item 16: Destination Aerodrome, Total EET, SAR Time (for flights in Canada only) and Destination Alternate Aerodrome(s)218
 - 3.16.7.1 Destination Aerodrome and Total EET (maximum 10 characters)218
 - 3.16.7.2 Destination Alternate Aerodrome(s)218
 - 3.16.8 Item 18: Other Information218
 - 3.16.9 Item 19: Supplementary Information220
 - 3.16.9.1 Endurance220
 - 3.16.9.2 Persons On Board220
 - 3.16.9.3 Emergency and Survival Equipment220

4.0 AIRPORT OPERATIONS 224

- 4.1 General224**
 - 4.1.1 Wake Turbulence224
 - 4.1.2 Noise Abatement225
 - 4.1.3 Preferential Runway Assignments226
- 4.2 Departure Procedures — Controlled Airports226**
 - 4.2.1 ATIS Broadcasts226
 - 4.2.2 Clearance Delivery226
 - 4.2.3 Radio Checks226
 - 4.2.4 Requests for Push-back or Power-back226
 - 4.2.5 Taxi Information226
 - 4.2.6 Taxi Holding Positions227
 - 4.2.7 Taxiway Holding Positions During IFR Operations227
 - 4.2.8 Take-Off Clearance228

4.2.9	Release from Tower Frequency	228
4.2.10	Departure Procedures - NORDO Aircraft	228
4.2.11	Visual Signals	229
4.2.12	Departure Procedures – RONLY Aircraft	229
4.3	Traffic Circuits — Controlled Aerodromes	229
4.4	Arrival Procedures — Controlled Airports	229
4.4.1	Initial Contact	229
4.4.2	Initial Clearance	230
4.4.3	Landing Clearance	230
4.4.4	Taxiing	231
4.4.5	Arrival Procedures – NORDO Aircraft	232
4.4.6	Arrival Procedures – RONLY Aircraft	232
4.4.7	Visual Signals	232
4.4.8	Communications Failure - VFR	232
4.4.9	Operations on Intersecting Runways	233
4.4.10	High Intensity Runway Operations (HIRO).....	235
4.5	Aircraft Operations—Uncontrolled Aerodromes	236
4.5.1	General	236
4.5.2	Traffic Circuit Procedures — Uncontrolled Aerodromes	236
4.5.3	Helicopter Operations	237
4.5.4	Mandatory Frequency	237
4.5.5	Aerodrome Traffic Frequency	238
4.5.6	Use of MF and ATF	238
4.5.7	VFR Communication Procedures at Uncontrolled Aerodromes with MF and ATF Areas	239
4.5.8	Aircraft Without Two-Way Radio (NORDO/RONLY)	239
4.5.8.1	Prior Arrangements	239
4.5.8.2	Traffic Circuits - NORDO/RONLY	240
4.5.8.3	RONLY	240
4.6	Helicopter Operations at Controlled Airports	240
5.0	VFR EN ROUTE PROCEDURES	240
5.1	Monitoring, Broadcasting on 126.7 MHz and Position Reporting En Route	240
5.2	Acknowledgement of Clearances	240
5.3	Altitudes and Flight Levels — VFR	240
5.4	Minimum Altitudes — VFR (CARs 602.14 and 602.15)	241
5.5	Minimum Altitudes — Overflying Aerodromes [CARs 602.96(4)and(5)].....	241
5.6	Controlled VFR (CVFR) Procedures	242
5.7	En route Radar Surveillance	242
5.8	VFR Operations Within Class C Airspace	242
6.0	INSTRUMENT FLIGHT RULES (IFR) — GENERAL	243
6.1	ATC Clearance	243
6.2	IFR Flights in VMC	243
6.2.1	IFR Clearance with VFR Restrictions	243
6.2.2	VFR Release of an IFR Aircraft	244
6.3	Emergencies and Equipment Failures — IFR	244
6.3.1	Declaration of Emergency	244
6.3.2	Two-Way Communications Failure	244
6.3.2.1	General	244
6.3.2.2	IFR Flight Plan	244
6.3.3	Reporting Malfunctions of Navigation and Communications Equipment	246
6.3.4	Fuel Dumping	246
6.4	IFR Separation	246
6.4.1	General	246
6.4.2	Vertical Separation — General	246
6.4.3	Vertical Separation Between Flight Levels and Altitudes ASL	246
6.4.4	Longitudinal Separation—Distance-Based	246
6.4.5	Lateral Separation — General	246
6.4.6	Lateral Separation — Airways and Tracks	247
6.4.7	Lateral Separation — Instrument Approach Procedure	247
6.5	Development of Instrument Procedures	247
7.0	INSTRUMENT FLIGHT RULES – DEPARTURE PROCEDURES	248
7.1	Aerodrome Operations	248
7.2	ATIS Broadcasts	248
7.3	Initial Contact	248

7.4	IFR Clearances	248
7.5	SID	248
7.6	Noise Abatement Procedures – Departure	250
7.6.1	General	250
7.6.2	Noise Preferential Runways	250
7.6.3	Noise Abatement Departure Procedures (NADP)	250
7.7	Obstacle and Terrain Clearance	252
7.7.1	Visual Climb Over the Airport (aerodrome)	252
7.8	Release from Tower Frequency	253
7.9	IFR Departures from Uncontrolled Airports	253
7.10	Alerting Service IFR Departures from Uncontrolled Airports	253
8.0	INSTRUMENT FLIGHT RULES (IFR) – EN ROUTE PROCEDURES	254
8.1	Position Reports	254
8.2	Future Air Navigation Systems 1/A Automatic Dependent Surveillance Waypoint Position Reporting (FANS 1/A ADS WPR)	254
8.2.1	ADS WPR	254
8.2.2	ATS Facilities Notification (AFN) Logon	255
8.2.3	Using ADS WPR	255
8.2.4	Aeradio Communications	255
8.2.4.1	Flight Crew Initial Contact with Edmonton Centre (Flight Is Radar Identified)	255
8.2.4.2	Flight Crew Initial Contact with Edmonton Centre (Flight Is Not Radar Identified)	255
8.2.4.3	Flight Crew Initial Contact with Gander Radio	255
8.2.4.4	Flight Crew Initial Contact with Arctic Radio	255
8.2.5	Satellite Communications (SATCOM) Shadow	256
8.3	Mach Number/True Airspeed—Clearances and Reports	256
8.3.1	Mach Number	256
8.3.2	TAS	256
8.4	Altitude Reports	256
8.5	Climb or Descent	257
8.5.1	General	257
8.5.2	Visual Climb and Descent	257
8.5.2.1	General	257
8.5.2.2	Visual Separation from Other Aircraft	257
8.6	Minimum IFR Altitudes	257
8.7	ATC Assignment of Altitudes	258
8.7.1	Minimum IFR Altitude	258
8.7.1.1	DME Intersections on a Minimum En-Route Altitude	259
8.7.2	Altitudes and Direction of Flight	259
8.8	“1 000-ft-on-Top” IFR Flight	259
8.9	Clearances—Leaving or Entering Controlled Airspace	260
8.10	Clearance Limit	260
8.11	Class G Airspace—Recommended Operating Procedures—En-Route	260
9.0	INSTRUMENT FLIGHT RULES (IFR) — ARRIVAL PROCEDURES	261
9.1	ATIS Broadcasts	261
9.2	Standard Terminal Arrival (STAR), Minimum Sector Altitude (MSA) and Terminal Arrival Area (TAA)	261
9.2.1	Conventional STAR	261
9.2.2	RNAV Equipment	261
9.2.3	RNAV STAR Procedure	261
9.2.4	MSA	263
9.2.5	TAA	264
9.3	Approach Clearance	264
9.4	Descent Out of Controlled Airspace	266
9.5	Advance Notice of Intent in Minimum Weather Conditions	266
9.6	Contact and Visual Approaches	266
9.6.1	Contact Approach	266
9.6.2	Visual Approach	266
9.7	Radar Arrivals	267
9.7.1	General	267
9.7.2	Radar Required	267
9.7.3	Speed Adjustment – Radar-Controlled Aircraft	267
9.7.4	Precision Radar Approaches	268
9.8	Initial Contact with Control Towers	268
9.9	Approach Position Reports— Controlled Airports	268

9.10	Control Transfer— IFR Units to Towers	268
9.11	Initial Contact with Air-to-Ground (A/G) Facility at Uncontrolled Aerodromes	269
9.12	Reporting Procedures for IFR Aircraft when Approaching or Landing at an Uncontrolled Aerodrome (CAR 602.104) (see RAC 4.5.4 and 4.5.5)	269
9.13	IFR Procedures at an Uncontrolled Aerodrome in Uncontrolled Airspace	269
9.14	Outbound Report	270
9.15	Straight-In Approach	270
9.16	Straight-In Approaches from an Intermediate Fix	270
9.17	Procedure Altitudes and Current Altimeter Setting	271
9.17.1	Corrections for Temperature	271
9.17.2	Remote Altimeter Setting	273
9.18	Departure, Approach and Alternate Minima	273
9.18.1	Category II ILS Approach Minima	273
9.19	Application of Minima	274
9.19.1	Take-Off Minima	274
9.19.2	Approach Ban	275
9.19.2.1	General Aviation—Non-Precision Approach (NPA), Approach Procedure with Vertical Guidance (APV), CAT I or CAT II Precision Approach.....	275
9.19.2.2	Approach Ban—General Aviation—CAT III Precision Approach.....	276
9.19.2.3	Approach Ban—Commercial Operators—General—Non-Precision Approach (NPA), Approach Procedure with Vertical Guidance (APV), or CAT I Precision Approach	276
9.19.2.4	Approach Ban—Commercial Operators—CAT II and CAT III Precision Approach.....	277
9.19.2.5	Approach Ban—Commercial Operators—Operations Specification—Non-Precision Approach (NPA), Approach Procedure with Vertical Guidance (APV), or CAT I Precision Approach	277
9.19.2.6	Runway Visibility	278
9.19.2.7	Localized Phenomenon.....	278
9.19.3	Landing Minima	278
9.20	Runway Visual Range	279
9.20.1	Definitions	279
9.20.2	Operational Use of RVR	279
9.21	Aircraft Categories	280
9.22	Straight-In Landing Minima	280
9.23	Circling	281
9.24	Circling Procedures	281
9.25	Missed Approach Procedure While Visually Manoeuvring in the Vicinity of the Aerodrome	281
9.26	Missed Approach Procedures	281
9.27	Simultaneous Precision Instrument Approaches - Parallel Runways	282
9.28	Simultaneous Precision Instrument Approaches - Converging Runways	282
10.0	INSTRUMENT FLIGHT RULES — HOLDING PROCEDURES	283
10.1	General	283
10.2	Holding Clearance	283
10.3	Standard Holding Pattern.....	283
10.4	Non-Standard Holding Pattern	284
10.5	Entry Procedures	284
10.6	Timing	284
10.7	Speed Limitations	285
10.8	DME Procedures	285
10.9	Shuttle Procedure	285
10.10	Holding Patterns Published on En-Route and Terminal Charts	286
11.0	NORTH ATLANTIC OPERATIONS	286
11.1	Regulation Reference Documents and Guidance Material	286
11.1.1	Regulation	286
11.1.2	NAT Documents and Guidance Material	286
11.2	General Aviation Aircraft	286
11.3	North American Routes	287
11.4	NAT Organized Track System	287
11.5	Flight Rules	287
11.6	Flight Planning Procedures	287
11.6.1	Routes	287
11.6.2	Airspeed	288
11.6.3	Altitude	288
11.6.4	Estimated Times	289
11.6.5	Aircraft Approval Status and Registration	289

11.6.6	Height Monitoring Unit (HMU)	289
11.6.7	Filing	289
11.7	Preferred Routes Messages	289
11.8	Clearances	290
11.8.1	Oceanic Clearances	290
11.8.2	Domestic Clearances – NAT Westbound Traffic	291
11.8.3	Oceanic Clearance Delivery	291
11.9	Position Reports	292
11.9.1	Requirements	292
11.9.2	Communications	292
11.10	Minimum Navigation Performance Specifications (MNPS)	292
11.11	Reduced Vertical Separation Minimum (RVSM)—Minimum Aircraft System Performance Specifications (MASPS)	293
11.12	Adherence to Mach Number	293
11.13	Operation of Transponders	293
11.14	Meteorological Reports	293
11.15	Adherence to Route	293
11.16	Step-Climb Procedure	293
11.17	Cruise Climbs and Altitude Reports	293
11.18	In-Flight Contingencies	293
11.19	Communications Failure–NAT Traffic	294
11.19.1	General	294
11.19.2	Communications Failure Prior to Entering NAT Oceanic Airspace	294
11.19.3	Communications Failure Prior to Exiting NAT Oceanic Airspace	294
11.20	North Atlantic Minimum Navigation Performance Specification Airspace	294
11.20.1	General	294
11.20.2	Time Keeping Procedures	295
11.20.3	Provisions for Partial Loss of Navigation Capability	295
11.20.4	Special Routes for Aircraft Fitted with a Single Long-Range Navigation System	295
11.20.5	Special Routes for Aircraft Fitted with Short-Range Navigation Equipment Operating Between Iceland and Other Parts of Europe	296
11.20.6	Aircraft Without MNPS Capability	296
11.20.7	Monitoring of Gross Navigation Errors	296
11.21	North Atlantic Reduced Vertical Separation Minimum	296
11.21.1	General	296
11.21.2	RVSM Details and Procedures	296
11.21.3	Flight Level Allocation Scheme	296
11.21.3.1	Flight Level Availability	296
11.21.3.2	Procedures	297
11.21.3.3	Delegated Opposite Direction Levels (ODL)	297
11.21.3.4	Eastbound Traffic Originating in New York/Santa Maria During Eastbound OTS Hours of Validity	298
11.21.3.5	Iberian Tracks	298
11.21.3.6	OTS Design and Use	298
11.21.3.7	OTS Changeover Periods	299
11.21.4	NAT RVSM Aircraft Approvals	300
11.21.5	Central Monitoring Agency (CMA)	300
11.21.6	Height Monitoring	300
11.21.7	Height Monitoring Unit (HMU)	300
11.21.8	GMU Monitoring	301
11.21.9	Further Information	301
11.22	Strategic Lateral Offset Procedures (SLOP) in the North Atlantic	301
12.0	AIR TRAFFIC CONTROL (ATC) SPECIAL PROCEDURES	302
12.1	Adherence to Mach Number	302
12.2	Parallel Offset Procedures	302
12.3	Structured Airspace	302
12.4	Required Navigation Performance Capability (RNP) Airspace	302
12.4.1	Definition	302
12.4.2	Aircraft Navigation Equipment for RNP	302
12.4.3	Operator Certification for RNP	303
12.4.4	Flight Planning Procedure	303
12.4.5	RNAV/DME Distance	303
12.4.6	RNAV Equipment Failure Procedures	303
12.5	CMNPS AIRSPACE	304
12.5.1	Definition	304
12.5.2	CMNPS Transition Airspace	304
12.5.3	Aircraft Navigation Equipment for CMNPS	304

12.5.4	Operator Certificate for CMNPS	304
12.5.5	Flight Planning Procedure	305
12.5.6	Partial or Complete Loss of Navigation Capability While Operating within CMNPS Airspace	305
12.5.7	Communications	305
12.6	Canadian Domestic Routes	305
12.6.1	General	305
12.6.2	North American Route Program (NRP).....	305
12.6.2.1	Introduction	305
12.6.2.2	Eligibility	305
12.6.2.3	Procedures	305
12.6.3	Preferred IFR Routes	305
12.6.4	Fixed RNAV Routes	306
12.6.5	Northern Control Area Random Routes	306
12.6.6	Arctic Control Area Random Routes	306
12.7	Canadian Track Structures	307
12.7.1	ACA Track System.....	307
12.7.1.1	General.....	307
12.7.1.2	Flight Planning Procedures	307
12.7.1.3	Position Reports	307
12.7.2	Northern Organized Track System.....	307
12.7.2.1	General.....	307
12.7.2.2	Track Coordination and Publication.....	307
12.7.2.3	Flight Planning Procedures	307
12.7.2.4	Position Reporting and Abbreviated Route Clearances Flights	308
12.7.3	NCA Track System	308
12.7.3.1	General.....	308
12.7.3.2	Flight Planning Procedures	308
12.7.3.3	Position Reports.....	308
12.7.3.4	NCA Tracks—NAT Traffic.....	308
12.7.3.5	NCA Tracks—PAC Traffic.....	309
12.7.4	SCA Track System	309
12.7.4.1	General.....	309
12.7.4.2	Flight Planning Procedures	309
12.7.4.3	Position Reports.....	309
12.7.5	NAR System.....	309
12.8	Security Control of Air Traffic	309
12.8.1	General	309
12.8.2	ESCAT Plan	309
12.9	Air Traffic Flow Management (ATFM)	310
12.10	Flow Control Procedures	311
12.11	Fuel Conservation High Level Airspace	311
12.12	Altimeter Setting Procedures During Abnormally High Pressure Weather Conditions	311
12.12.1	General	311
12.12.2	Flight Procedures	312
12.13	Formation Flight Procedures	312
12.13.1	General	312
12.13.2	Formation Flight Planning Procedures	312
12.13.3	IFR and CVFR Formation Flight	313
12.14	Photographic Survey Flights	313
12.15	Safety Alert Procedure and Phraseology	313
12.15.1	General.....	313
12.15.2	Controller Phraseology.....	314
12.15.3	ATC Conflict Alert Software.....	314
12.15.4	Use of the Terms Traffic Alert and Airspace Alert as Part of an Avoidance Instruction	314
12.15.5	Controller Phraseology	314
12.16	Traffic Alert and Collision Avoidance Systems and Airborne Collision Avoidance Systems	314
12.16.1	General	314
12.16.2	Use of TCAS/ACAS	314
12.16.3	Transport Canada TCAS/ACAS Policy	315
12.16.4	Operational Approval	315
12.16.5	Airworthiness Approval	315
12.16.6	Pilot Immunity from Enforcement Action for Deviating from Clearances	315
12.16.7	Mode S Transponder Approval and Unique Codes	316
12.16.8	Pilot/Controller Actions	316
12.16.9	Pilot and Controller Phraseology	316
12.16.10	Recommended Use	316

12.17 Reduced Vertical Separation Minimum (RVSM) 316

12.17.1 Definitions 316

12.17.2 RVSM Airspace 317

12.17.3 ATC Procedures 317

12.17.4 In-Flight Procedures 317

12.17.5 Flight Planning Requirements 317

12.17.6 Operation of Non-RVSM Aircraft in RVSM Airspace 318

12.17.7 Delivery Flights for Aircraft that are RVSM-Compliant on Delivery 318

12.17.8 Airworthiness and Operational Approval and Monitoring 318

12.17.9 Monitoring 319

12.17.10 NAARMO 319

12.17.11 ACAS II 319

12.17.12 Mountain Wave Activity (MWA) 319

12.17.13 Wake Turbulence 320

12.17.14 In-Flight Contingencies 321

RAC ANNEX 322

1.0 General 322

2.0 Canadian Aviation Regulations 322

3.0 Transportation of Dangerous Goods (TDG) by Air 330

FAL – FACILITATION 333

1.0 GENERAL INFORMATION 333

1.1 General 333

1.2 Designated Authorities 333

2.0 ENTRY, TRANSIT AND DEPARTURE OF AIRCRAFT 334

2.1 General 334

2.2 Commercial Flights 334

2.2.1 Aerodrome Use for Commercial Flights 334

2.2.2 International Commercial Flights Operating into and out of Canada or Transiting Canadian Airspace 334

2.2.3 Use of DND and Civil High Arctic Aerodromes 337

2.2.4 Documents Required by Passengers for Canadian Inspection Services 337

2.2.5 Requirement for Visas 338

2.2.6 Documents Required by CIS for Cargo/Passenger Baggage 338

2.3 Private Flights 338

2.3.1 General 338

2.3.2 Transborder Flights 339

2.3.3 Documentary Requirements for Customs Clearance of Aircraft 339

2.3.4 Public Health Measures and Requirements Regarding Passports and Visas 340

2.4 Public Health Measures Applied to Aircraft 340

2.5 Regulations Concerning the Importation of Plants and Animals 340

3.0 FEES AND CHARGES 341

3.1 Airport Fees 341

3.2 Air Navigation Service Charges (NAV CANADA) 341

3.2.1 En-Route and Terminal Air Navigation Services 341

3.2.1.1 Annual Charges for Small Aircraft 341

3.2.1.2 Daily Charges for Propeller Aircraft Over Three Metric Tons (Including Helicopters and Small Jet Aircraft) 341

3.2.1.3 Movement-Based Charges for Jet Aircraft Over 3 Metric Tons 341

3.2.2 Oceanic Services 341

3.2.2.1 NAT En-Route Facilities and Services Charge 341

3.2.2.2 International Communication (Int'l Comm) Services Charge 341

3.2.3 Customer Service and Account Inquiries 341

3.3 Charges for Customs Services 342

3.4 Penalties for Customs Violations 342

SAR – SEARCH AND RESCUE 343

1.0 RESPONSIBLE AUTHORITY 343

1.1 General 343

1.2 Types of Service Available 343

1.3 SAR Agreements 343

2.0 FLIGHT PLANNING	344
2.1 General	344
2.2 Request for SAR Assistance	344
2.3 MANOT	344
2.4 Aiding Persons in Distress	345
3.0 EMERGENCY LOCATOR TRANSMITTER	346
3.1 General	346
3.2 Categories of ELT	346
TYPE P	346
3.3 Installation and Maintenance Requirements	346
3.4 ELT Operating Instructions (Normal Use)	346
3.5 ELT Operating Instructions (Emergency Use)	347
3.6 Maximizing the Signal	347
3.7 Accidental ELT Transmissions	348
3.8 Testing Procedures	348
3.9 Schedule of Requirements	349
4.0 AIRCRAFT EMERGENCY ASSISTANCE	349
4.1 Declaring an Emergency	349
4.2 Action by the Pilot During Emergency Conditions	349
4.3 VHF Direction-Finding Assistance.....	350
4.4 Transponder Alerting	350
4.5 Radar Alerting Manoeuvres	350
4.6 Emergency Radio Frequency Capability	350
4.7 Interception Procedures (CAR 602.144)	351
4.8 Downed Aircraft Procedures	354
4.8.1 Ground-to-Air Signals	354
4.8.2 Survival	354
4.9 <i>Canada Shipping Act, 2001 (2001,</i> <i>C. 26) EXTRACT—PART 5, SECTIONS 130–133.....</i>	<i>355</i>

MAP – AERONAUTICAL CHARTS AND PUBLICATIONS

357

1.0 GENERAL INFORMATION	357
1.1 General	357
1.2 Preflight Reference Information	357
1.3 Inflight Information	357
2.0 AERONAUTICAL INFORMATION – VFR	357
2.1 General	357
2.2 Index to Canadian Aeronautical Charts	358
2.3 Updating of Canadian Aeronautical Charts	358
2.4 Chart Updating Data	358
3.0 AERONAUTICAL INFORMATION – IFR	358
3.1 General	358
3.2 En-Route Products	359
3.2.1 Low Altitude	359
3.2.2 High Altitude	359
3.3 Terminal Products	359
3.3.1 Terminal Area Charts	359
3.3.2 Terminal Instrument Procedures	359
3.4 Canada Flight Supplement	360
3.5 Publication Revision Cycles	360
3.6 Aerodrome Obstacle Charts – ICAO Type A	360
3.6.1 General	360
3.6.2 Index of Aerodrome Obstacle Charts – ICAO Type A (Operating Limitations).....	360
4.0 INFORMATION COLLECTION	362
4.1 Responsibility	362
4.2 Correction Card System	362

5.0	NOTAM	362
5.1	General	362
5.2	NOTAM Distribution—Canadian	362
5.3	NOTAM Distribution—International	362
5.4	Criteria for Issuing a NOTAM	362
5.5	NOTAM Summaries	363
5.5.1	Summary Distribution Schedule	363
5.6	NOTAM Format	364
5.6.1	General	364
5.6.1.1	Date-Time Group	364
5.6.1.2	NOTAM Time Schedule	364
5.6.2	New NOTAM (NOTAMN)	364
5.6.3	Replacing NOTAM (NOTAMR)	364
5.6.4	Cancelling NOTAM (NOTAMC)	364
5.6.5	Permanent Changes to Aeronautical Data	364
5.6.6	RSC/CRFI NOTAM (NOTAMJ)	364
5.6.7	Query/Response NOTAM (NOTAMQ)	364
5.6.8	Automatic Query/Response—Canadian International NOTAM Database	364
5.6.9	Response Delivery	364
5.6.10	NOTAM Files	365
6.0	AIP CANADA (ICAO) SUPPLEMENTS, AERONAUTICAL INFORMATION CIRCULARS, AIRAC CANADA	365
6.1	General	365
6.2	AIP Canada (ICAO) Supplement	365
6.3	Aeronautical Information Circular	366
6.4	AIRAC Canada	366
7.0	PROCUREMENT OF AERONAUTICAL CHARTS AND PUBLICATIONS	366
7.1	Publishing and Depository Services	366
7.2	NAV CANADA	367
7.2.1	Subscriptions	367
8.0	CHARTS AND PUBLICATIONS FOR INTERNATIONAL FLIGHTS	368
8.1	General	368

LRA – LICENSING, REGISTRATION AND AIRWORTHINESS 369

1.0	FLIGHT CREW LICENSING	369
1.1	General	369
1.2	Aviation Document Booklet	369
1.3	Aviation Language Proficiency	369
1.4	Permits and Licences issued by Transport Canada Civil Aviation (TCCA)	370
1.4.1	Permits	370
1.4.2	Licences	370
1.5	Definitions of Flight Experience	370
1.6	Summary of Requirements for Permits	370
1.6.1	Student Pilot Permits	371
1.6.2	Pilot Permits	371
1.7	Summary of Requirements for Licences	372
1.7.1	Pilot Licence	372
1.7.2	Private Pilot Licence (PPL)	372
1.7.3	Commercial Pilot Licence (CPL)	373
1.7.4	Airline Transport Pilot Licence (ATPL)	373
1.7.5	Multi-Crew Pilot Licence (MPL)	373
1.7.6	Flight Engineer Licence	374
1.8	Licence Differences with ICAO Standards and Recommended Practices	374
1.8.1	General Rules Concerning Licences (Chapter 1)	374
1.8.2	Licences and Ratings for Pilots (Chapter 2)	375
1.9	Medical Fitness for Permits and Licences	375
1.9.1	Medical Validity Periods	376
1.9.2	Medical Fitness: Renewals for Category 1, 2 or 3 Medical Certificates (Assessed Fit)	376
1.9.3	Medical Fitness: Renewals for Category 4 Medical Certificate	376
1.9.4	Medical Fitness: Assessed Unfit	377

1.10	Refusal to Issue a Permit, Licence, Rating or Medical Certificate	377
1.11	Reinstatement of a Suspended Permit, Licence or Rating	377
1.12	Recency Requirements	377
1.13	Flight Crew Licensing Conversion Agreement Between Canada and the United States	378
1.14	Flight Crew Licensing Administration	378
2.0	Civil Aviation Medicine (CAM)	378
2.1	Medical Assessment Process	378
2.1.1	Medical Examination Report	378
2.1.2	Category 4 Medical Declaration	379
2.2	Medical Examination Requirements	380
2.3	Periodic Medical Exam Categories 1, 2, 3 - Medically Fit	380
2.4	Aviation Medical Review Board	380
2.5	Unfit Assessment	380
2.6	Review by the Transportation Appeal Tribunal of Canada (TATC)	381
3.0	FLIGHT CREW EXAMINATIONS.....	382
3.1	Use of Hand-Held Calculators or Computers for Written Examinations	382
4.0	AIRCRAFT IDENTIFICATION, MARKING, REGISTRATION AND INSURANCE	382
4.1	General	382
4.2	Aircraft Identification	382
4.3	Nationality and Registration Marks	382
4.4	Change of Ownership—Canadian-Registered Aircraft	383
4.5	Initial Registration	383
4.6	Importation of Aircraft Into Canada	383
4.7	Exportation of Aircraft	383
4.8	Liability Insurance	384
5.0	AIRCRAFT AIRWORTHINESS	384
5.1	General	384
5.2	Aircraft Design Requirements	384
5.2.1	General	384
5.2.2	Canadian Type Certificate (CARs, Part V, Subpart 21)	384
5.3	Flight Authority and Noise Compliance	385
5.3.1	General	385
5.3.2	Certificates of Airworthiness	385
5.3.3	Special Certificates of Airworthiness	385
5.3.4	Flight Permit	385
5.3.5	Noise Compliance	386
5.4	Maintenance Certification	386
5.4.1	General	386
5.4.2	Certification of Maintenance Performed Outside Canada	386
5.5	Annual Airworthiness Information Report	386
5.6	Maintenance Requirements for Canadian-Registered Aircraft	387
5.6.1	General	387
5.6.2	Maintenance Schedules	387
5.6.3	Maintenance Performance	387
5.6.4	Aircraft Technical Records.....	387
5.6.5	Service Difficulty Reporting (SDR) Program	388
5.7	Airworthiness Directives.....	388
5.7.1	General	388
5.7.2	Availability of ADs.....	388
5.7.3	AD Schedule and Compliance Records	388
6.0	THE TRANSPORTATION APPEAL TRIBUNAL OF CANADA (TATC)	388
6.1	General	388
6.2	Refusal to Issue or Amend a Canadian Aviation Document	389
6.3	Suspension, Cancellation or Refusal to Renew	389
6.4	Monetary Penalties	389
6.5	Appeals	390

7.0	CANADIAN AVIATION REGULATION ADVISORY COUNCIL (CARAC)	390
7.1	General	390
7.2	Introduction	390
7.3	Governing Principles	390
7.4	Objective	391
7.5	Organization Structure	391
7.6	Project Resources	391
7.7	Communication and External Relationships	391
7.8	Information	391
7.9	Web Site	391
8.0	CIVIL AVIATION ISSUES REPORTING SYSTEM (CAIRS)	392
8.1	Introduction	392
9.0	LRA ANNEX - AIRCRAFT AIRWORTHINESS	392
9.1	General	392

AIR – AIRMANSHIP 393

1.0	GENERAL INFORMATION	393
1.1	General	393
1.2	Pilot Vital Action Checklists	393
1.3	Aviation Fuels	393
1.3.1	Fuel Grades	393
1.3.2	Aviation Fuel Handling	393
1.3.3	Fuel Anti-Icing Additives	393
1.3.4	Fires and Explosions	394
1.4	Aircraft Hand Fire Extinguishers	394
1.4.1	General	394
1.4.2	Classification of Fires	394
1.4.3	Types of Extinguishers	395
1.5	Pressure Altimeter	395
1.5.1	General	395
1.5.2	Calibration of the Pressure Altimeter	395
1.5.3	Incorrect Setting on the Subscale of the Altimeter	396
1.5.4	Non-Standard Temperatures	396
1.5.5	Standard Pressure Region	397
1.5.6	Effect of Mountains	397
1.5.7	Downdraft and Turbulence	397
1.5.8	Pressure Drop	397
1.5.9	Abnormally High Altimeter Settings	397
1.6	Canadian Runway Friction Index (CFRI)	398
1.6.1	General	398
1.6.2	Reduced Runway Coefficients of Friction and Aircraft Performance	398
1.6.3	Description of CRFI and Method of Measurement	398
1.6.4	Aircraft Movement Surface Condition Reports (AMSCR)	398
1.6.5	Wet Runways	400
1.6.6	CRFI Application to Aircraft Performance	400
1.7	Jet and Propeller Blast Danger	404
1.8	Marshalling Signals	405
2.0	FLIGHT OPERATIONS	409
2.1	General	409
2.2	Crosswind Landing Limitations	409
2.3	Carburetor Icing	409
2.4	Low Flying	409
2.4.1	Flying Near Power Lines	410
2.4.2	Logging Operations	410
2.5	Flight Operations in Rain	411
2.6	Flight Operations in Volcanic Ash	411
2.7	Flight Operation Near Thunderstorms	411
2.7.1	General	411
2.7.2	Considerations	412
2.8	Low Level Wind Shear	412

2.9	Wake Turbulence	413
2.9.1	Vortex Characteristics	413
2.9.2	Considerations	414
2.10	Clear Air Turbulence.....	415
2.11	Flight Operations on Water	416
2.11.1	General	416
2.11.2	Ditching	416
2.11.3	Life-Saving Equipment For Aircraft Operating Over Water	416
2.11.4	Landing Seaplanes on Glassy Water	416
2.12	Flight Operations in Winter	417
2.12.1	General	417
2.12.2	Aircraft Contamination on the Ground – Frost, Ice or Snow	417
2.12.3	Aircraft Contamination in Flight – Inflight Airframe Icing	420
2.12.3.1	Types of Ice	420
2.12.3.2	Aerodynamic Effects of Airborne Icing	420
2.12.3.3	Roll Upset	421
2.12.3.4	Tail Plane Stall	421
2.12.3.5	Freezing Rain, Freezing Drizzle, and Large Super-Cooled Droplets	422
2.12.3.6	Detecting Large Super-Cooled Droplets Conditions in Flight	422
2.12.3.7	Flight Planning or Reporting	423
2.12.4	Landing Wheel-Equipped Light Aircraft on Snow Covered Surfaces	423
2.12.5	Use of Seaplanes on Snow Surfaces	423
2.12.6	Landing Seaplanes on Unbroken Snow Conditions	423
2.12.7	Whiteout	423
2.13	Flight Operations in Mountainous Areas	424
2.14	Flight Operations in Sparsely Settled Areas of Canada	424
2.14.1	Single-Engine Aircraft Operating in Northern Canada	425
2.15	Automatic Landing Operations	426
2.16	Flight Operations at Night	426
3.0	MEDICAL INFORMATION	426
3.1	General Health	426
3.1.1	Mandatory Medical Reporting	426
3.2	Specific Aeromedical Factors	426
3.2.1	Hypoxia	426
3.2.2	Carbon Monoxide	427
3.2.3	Hyperventilation	427
3.3	Decompression Sickness.....	427
3.4	Scuba Diving.....	428
3.5	Vision	428
3.6	Middle-Ear and Sinus Discomfort or Pain	428
3.7	Disorientation	429
3.8	Fatigue	429
3.9	Alcohol.....	429
3.10	Drugs	429
3.11	Anaesthetics.....	429
3.12	Blood Donation.....	430
3.13	Immunizations.....	430
3.14	Pregnancy	430
3.15	Positive and Negative G	430
3.15.1	What is G?	430
3.15.2	The Effects of G.....	431
3.15.3	G Straining Manoeuvres.....	431
3.15.4	Dealing with G.....	432
4.0	MISCELLANEOUS	432
4.1	Air Time and Flight Time	432
4.2	Conduct of Experimental Test Flights	432
4.3	Practice Spins	433
4.4	Cargo Restraint	433
4.4.1	General	433
4.4.2	Regulations	433
4.4.3	Guidelines	433
4.4.4	References	433
4.4.5	Approval	433

4.5	Collision Avoidance – Use of Landing Lights	434
4.6	Use of Strobe Lights	434
4.7	Manned Free Balloon Operations	434
	4.7.1 Balloon Operations with Fare-Paying Passengers	434
4.8	Parachute Jumping/Skydiving	434
4.9	Hang Glider and Paraglider Operations	435
4.10	Ultralight Aeroplane	435
4.11	Circuit Breakers and Alerting Devices	435
4.12	Design Eye Reference Point	436
4.13	First Aid Kits on Privately Owned and Operated Aircraft	436
AIR ANNEX		437
1.0	Survival Advisory Information	437

GEN – GENERAL

1.0 GENERAL INFORMATION

1.1 AERONAUTICAL INFORMATION

1.1.1 Aeronautical Authority

Transport Canada is the responsible aeronautical authority in Canada.

Postal Address

Assistant Deputy Minister
Transport Canada, Safety and Security
330 Sparks Street
Ottawa ON K1A 0N8

Aeronautical Fixed Telecommunication
Network (AFTN):CYHQYAYB

The Transport Canada, Aerodromes and Air Navigation Branch is responsible for the establishment and administration of the Regulations and Standards for the provision of AIS in Canada.

Enquiries relating to regulations and standards for AIS should be addressed to:

Postal Address:

Transport Canada (AARTA)
Aerodrome and Air Navigation Standards
330 Sparks Street
Ottawa ON K1A 0N8

Fax: 613-954-1602

TRANSPORT CANADA REGIONAL OFFICES

Transport Canada has five Regional Offices:

Pacific Region

Transport Canada
Suite 620
800 Burrard Street
Vancouver BC V6Z 2J8

Aerodromes and Air Navigation: 604-666-2103
General Aviation: 604-666-5571
Aviation Maintenance and Manufacturing: . 604-666-5596
Aircraft Certification: 604-666-2535
Aviation Enforcement: 604-666-5586
Commercial and Business Aviation: 604-666-5657
Civil Aviation Medicine: 604-666-5601
System Safety: 604-666-9517
Fax: 604-666-1175

Prairie and Northern Region

Transport Canada
344 Edmonton Street
P.O. Box 8550
Winnipeg MB R3C 0P6

Aerodromes and Air Navigation: 204-983-4335
General Aviation: 204-983-4341
Aviation Maintenance and Manufacturing: . 204-983-4352
Aircraft Certification: 204-984-7713
Aviation Enforcement: 204-983-4348
Commercial and Business Aviation: 204-983-3139
System Safety: 204-983-5870
Fax: 204-983-7339

Transport Canada
Canada Place
1100 – 9700 Jasper Avenue
Edmonton AB T5J 4E6

Aerodromes and Air Navigation: 780-495-3850
General Aviation: 780-495-2764
Aviation Maintenance and Manufacturing: 780-495-5224
Aircraft Certification: 780-495-7412
Aviation Enforcement: 780-495-3993
Commercial and Business Aviation: 780-495-3873
Civil Aviation Medicine: 780-495-3848
System Safety: 780-495-3861
Fax: 780-495-5190

Transport Canada Centre
800, 1601 Airport Rd, NE
Calgary AB T2E 6Z8

General Inquiries: 403-292-5942
General Aviation: 403-292-5227
Aviation Maintenance and Manufacturing: 403-292-5007
Commercial and Business Aviation: 403-292-5018

Ontario Region

Transport Canada
4900 Yonge Street, 4th Floor
Toronto ON M2N 6A5

Tel: 1-888-231-2330
Fax: 1-877-822-2129

Quebec Region

Transport Canada
700 Leigh Capr el
Dorval QC H4Y 1G7

Telephone: 514-633-3030
Fax: 514-633-3052

Atlantic Region

Transport Canada
P.O. Box 42
Moncton NB E1C 8K6

Operations: 506-851-6633
Civil Aviation Services: 506-851-7131
Aviation Enforcement: 506-851-7483
Civil Aviation Medicine: 1-888-764-3333
System Safety: 506-851-7110
Fax: 1-855-726-7495

Figure 1.1 – Transport Canada Regions

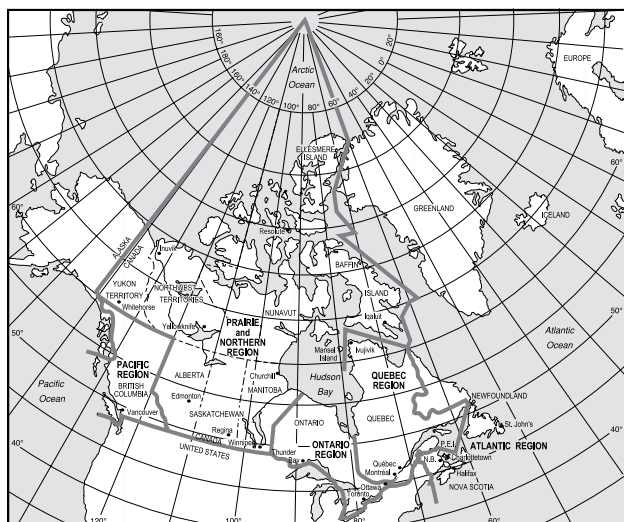

1.1.2 AIS

NAV CANADA, AIS is responsible for the collection, evaluation and dissemination of aeronautical information published in the *AIP Canada (ICAO)*, CFS, the WAS, the CAP and aeronautical charts. In addition, AIS assigns and controls Canadian location indicators and aircraft operating agency designators. (For information on the dissemination of aeronautical information and aeronautical products, see the MAP section.)

Postal Address

NAV CANADA
 Aeronautical Information Services
 77 Metcalfe Street
 Ottawa ON K1P 5L6
 Tel.: 613-563-5553
 Fax: 613-563-5602

Any errors, omissions, anomalies, suggestions or comments on the air navigation system can be submitted via any FIC.

Comments on the Air Navigation System

To report any concerns about the safety or quality of services provided by NAV CANADA, please contact the local NAV CANADA Site Manager or our Customer Service Centre at:

NAV CANADA Customer Service

Tel.: 1-800-876-4693-4*
 (*Disregard the last digit when calling within North America)
 Fax: 613-563-3426
 E-mail: service@navcanada.ca
 Regular hours of operation: 08:00–18:00 EST/EDT

1.1.3 Aeronautical Information Publications

TC AIM

The *Transport Canada Aeronautical information Manual* (TC AIM) has been developed to consolidate pre-flight reference information of a lasting nature into a single primary

document. It provides flight crews with a single source for information concerning rules of the air and procedures for aircraft operation in Canadian airspace. It includes those sections of the CARs that are of interest to pilots.

Throughout the TC AIM, the term “should” implies that Transport Canada encourages all pilots to conform with the applicable procedure. The term “shall” implies that the applicable procedure is mandatory because it is supported by regulations.

The rules of the air and air traffic control procedures are, to the extent practical, incorporated into the main text of the TC AIM in plain language. Where this was not possible, the proper CARs have been incorporated verbatim into the Annexes; however, editorial liberties have been taken in the deletion of definitions not considered essential to the understanding of the intent of the CARs. This has been done to enhance comprehension of the rules and procedures essential to the safety of flight. The inclusion of these rules and procedures in this format does not relieve persons concerned with aviation from their responsibilities to comply with all *Canadian Aviation Regulations* as published in the *Aeronautics Act* and CARs. Where the subject matter of the TC AIM is related to CARs, the legislation is cited.

In the compilation of the TC AIM, care has been taken to ensure that the information it contains is accurate and complete. Any correspondence concerning the content of the TC AIM is to be referred to:

TC AIM Co-ordinator (AARTT)
 Transport Canada
 330 Sparks Street
 Ottawa ON K1A 0N8
 Tel.: 613-993-4502
 Fax: 613-952-3298
 E-mail: alain.piche@tc.gc.ca

AIP Canada (ICAO)

The *AIP Canada (ICAO)* is published and disseminated by NAV CANADA and is an ICAO compliant publication intended primarily to satisfy international requirements for the exchange of aeronautical information of a lasting nature. It contains or provides reference to basic permanent and long-duration temporary Canadian aeronautical information. The *AIP Canada (ICAO)* is the main information source for basic Canadian aeronautical information required by ICAO, including Supplements and AICs.

AIP Canada (ICAO) pre-flight and in-flight information is provided in the following documents and charts: CFS, WAS, CAP (Volumes 1 to 7), *Enroute Low Altitude Charts* (GPH206), *Enroute High Altitude Charts* (GPH207), *Terminal Area Charts*, *Plotting Charts*, *Aeronautical Charts for Visual Navigation* and the DAH (TP 1820E). These documents and charts are designated supplements and form an integral part of the *AIP Canada (ICAO)*, in that they provide pre-flight and in-flight information necessary for the safe and efficient movement of aircraft in Canadian airspace. In due course, the

above publications and charts will be annotated to reflect their relationship to the TC AIM and to the *AIP Canada (ICAO)*.

Any correspondence concerning the content of the *AIP Canada (ICAO)* is to be referred to:

Ernie Szelepcsenyi
AIP Canada (ICAO) Co-ordinator
 NAV CANADA
 1601 Tom Roberts Avenue
 Ottawa ON K1V 1E5

Tel.: 613-248-4157
 Fax: 613-248-4093
 E-mail: aipcoord@navcanada.ca

1.1.4 TC AIM Publication Information

Individual copies of the TC AIM may be purchased by logging onto the Transport Canada Publication Storefront Web site at www.tc.gc.ca/TRANSACT. All information with respect to purchases and subscriptions to the TC AIM will be available on this Web site, or by contacting the Order Desk.

This edition of the TC AIM is designed to be as inexpensive as possible since it is intended primarily for student pilots and foreign pilots for use over a short period of time.

The TC AIM is available on the Transport Canada Web site at: www.tc.gc.ca/eng/civilaviation/publications/tp14371-menu-3092.htm.

Amendment Service

This document is intended to provide users of Canadian airspace with current information. A regular amendment service is established to advise individuals of changes to the airspace, regulations or procedures. New editions of the TC AIM are issued two times per year in phase with the ICAO Aeronautical Information Regulation and Control (AIRAC) schedule. Future issue dates are as follows:

2013-1 – April 04, 2013	2013-2 – October 17, 2013
2014-1 – April 03, 2014	2014-2 – October 16, 2014
2015-1 – April 02, 2015	2015-2 – October 15, 2015
2016-1 – March 31, 2016	2016-2 – October 13, 2016

Each new edition of the TC AIM includes an explanation of changes section that highlights the most significant changes made to the TC AIM and may provide a reference to detailed information on the change.

Distribution

To ensure uninterrupted service or to rectify any distribution problems, please contact:

The Order Desk
 Multimedia Products and Services (AARA-MPS)
 Transport Canada
 2655 Lancaster Road, Unit 100
 Ottawa ON K1B 4L5

Tel.: 1-888-830-4911 (in North America)
 613-991-4071 (international)

Fax: 613-991-1653
 E-mail: mps@tc.gc.ca
 Internet: www.tc.gc.ca/eng/civilaviation/opssvs/secretariat-763.htm

Please include your name, address, telephone number and licence number with all correspondence.

1.1.5 NOTAM

NAV CANADA, International NOTAM Office (NOF), is responsible for the collection, evaluation and dissemination of NOTAM. A complete description of the Canadian NOTAM system is located in MAP 5.0.

Postal Address

NAV CANADA
 International NOTAM Office
 Combined ANS Facility
 1601 Tom Roberts Avenue
 P.O. Box 9824 Stn. T
 Ottawa ON K1G 6R2

Tel.: 613-248-4000
 Fax: 613-248-4001
 AFTN: CYHQYNYX

1.1.6 Aerodromes

Complete information for all Canadian aerodromes is published in the CFS. ICAO Type A Charts are available from NAV CANADA, AIS (see MAP 3.6).

1.2 SUMMARY OF NATIONAL REGULATIONS

Civil aviation in Canada is regulated by the *Aeronautics Act* and the CARs. (See MAP 7.2 for procurement of the CARs). A legislation index is located in GEN 5.3.

1.3 DIFFERENCES WITH ICAO STANDARDS, RECOMMENDED PRACTICES AND PROCEDURES

Differences with ICAO Standards and Recommended Practices are listed in the appropriate ICAO Annexes and the *AIP Canada (ICAO)*, section GEN 1.7. However, differences with ICAO Procedures are listed in the TC AIM.

1.3.1 ICAO's Procedures for Air Navigation Services—Aircraft Operations (PANS OPS)

Canada does not use ICAO's *Procedures for Air Navigation Services—Aircraft Operations (PANS OPS)*. Instead, Canada uses TP 308, *Criteria for the Development of Instrument Procedures*, which is a document developed and produced by Transport Canada, Aerodromes and Air Navigation.

1.4 ABBREVIATIONS, ACRONYMS AND INITIALISMS

A list of the abbreviations, acronyms and initialisms that are used in the TC AIM is located in GEN 5.2. Those that apply to meteorology are contained in MET 3.6.

1.5 UNITS OF MEASUREMENT

The Imperial system of units is used for all information contained on aeronautical charts and publications.

1.5.1 Other Units

Other units are given in the following table and apply to specific situations.

MEASUREMENT	UNITS
Altimeter setting	inches of mercury
Altitudes, elevations and heights	feet
Distance used in navigation	nautical miles
Horizontal speed	knots
Relatively short distances	feet
Runway Visual Range (RVR)	feet
Temperature	degrees Celsius
Tire Pressure	pounds per square inch megapascals
Vertical speed	feet per minute
Visibility	statute miles
Weight	pounds kilograms kilonewtons
Wind direction, except for landing and takeoff	degrees true
Wind direction observations for landing and takeoff <i>*Degrees true in the Northern Domestic Airspace</i>	degrees magnetic
Wind speed	knots

1.5.2 Geographic Reference

Geographic co-ordinates are determined using the North American Datum 1983 (NAD83). Canada has deemed NAD83 co-ordinates to be equivalent to the World Geodetic System 1984 (WGS-84) for aeronautical purposes.

1.6 TIME SYSTEM

Co-ordinated Universal Time, abbreviated UTC, Zulu (Z) or spoken Universal, is used in Canadian aviation operations and is given to the nearest minute. Time checks are given to the nearest 15 seconds. The day begins at 0000 hours and ends at 2359 hours.

1.6.1 Date-Time Group

Date and time are indicated by a date-time group, which is a combination of the date and time in a single six-figure group. When used in the text of NOTAM, the date-time group is composed of ten figures, e.g., 9501191200. The first two digits indicate the year; the second two, the month; the third two, the day; and the last four, the hour and the minutes.

1.6.2 Morning and Evening Twilight Charts

In the morning, civil twilight begins when the centre of the sun's disc is 6° below the horizon and is ascending, and ends at sunrise, approximately 25 min later. In the evening, civil twilight begins at sunset, and ends when the centre of the sun's disc is 6° below the horizon and is descending, approximately 25 min later.

INSTRUCTIONS

1. Start at the top or bottom of the scale with the appropriate date and move vertically, up or down to the curve of the observer's latitude.
2. From the intersection move horizontally and read the local time.
3. To find the exact zone or standard time, ADD 4 minutes for each degree west of the standard meridian, or SUBTRACT 4 minutes for each degree east of the standard meridian. The standard meridians in Canada are: AST-60W; EST-75W; CST-90W; MST-105W; PST-120W

Beginning of Morning Civil Twilight on Standard Meridian of Time Zone

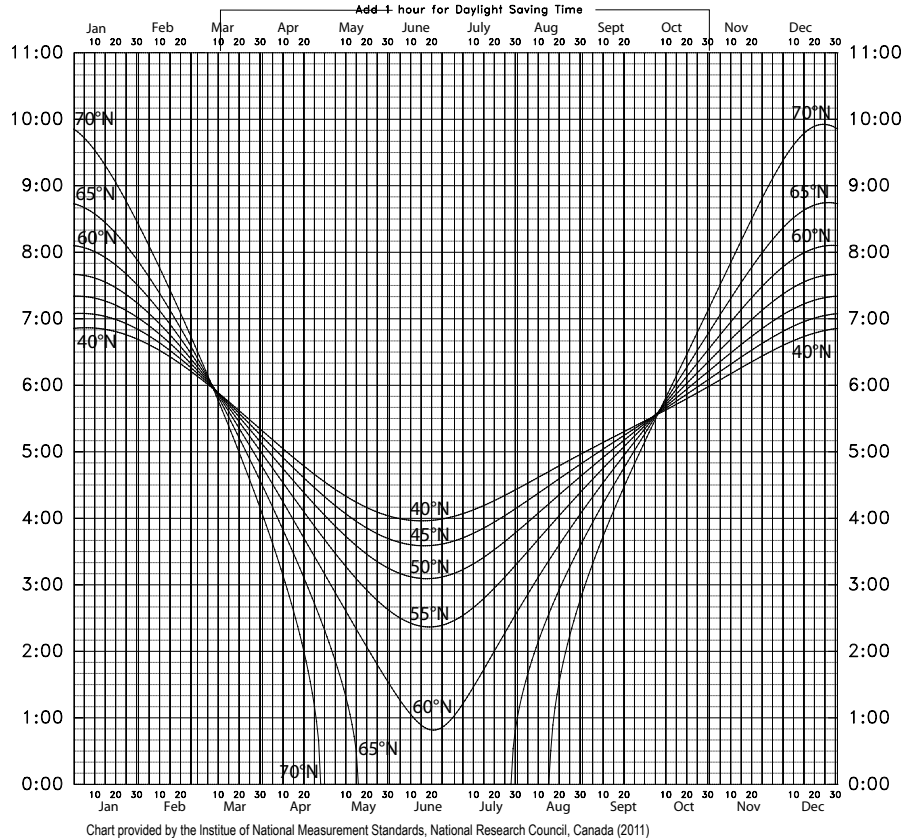

Chart provided by the Institute of National Measurement Standards, National Research Council, Canada (2011)

End of Evening Civil Twilight on Standard Meridian of Time Zone

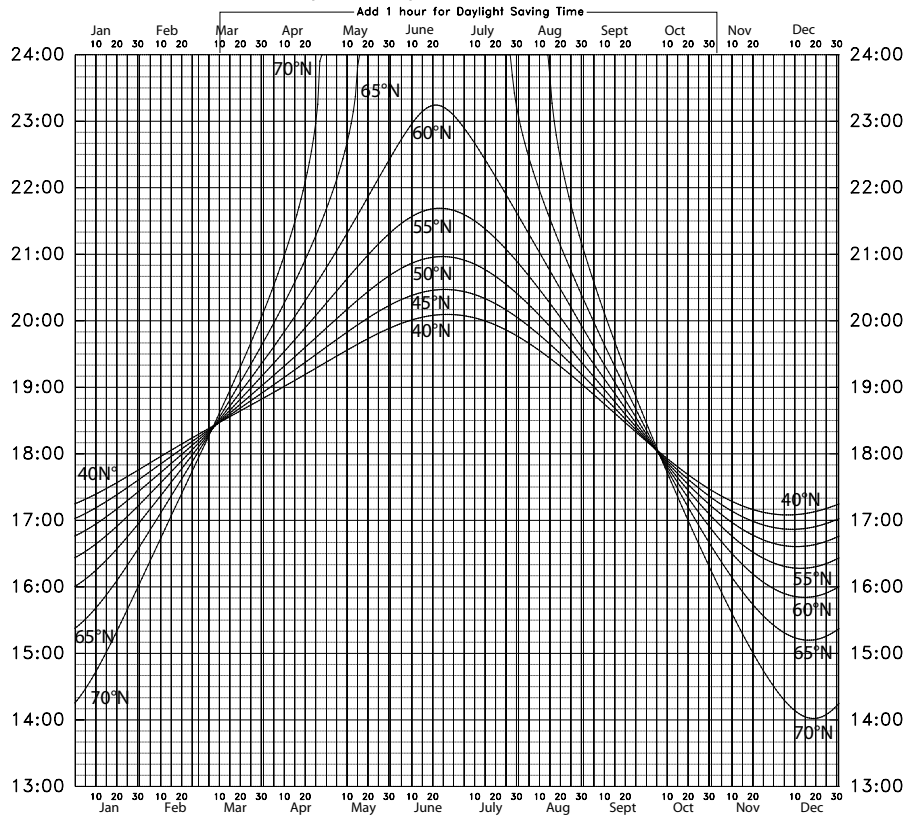
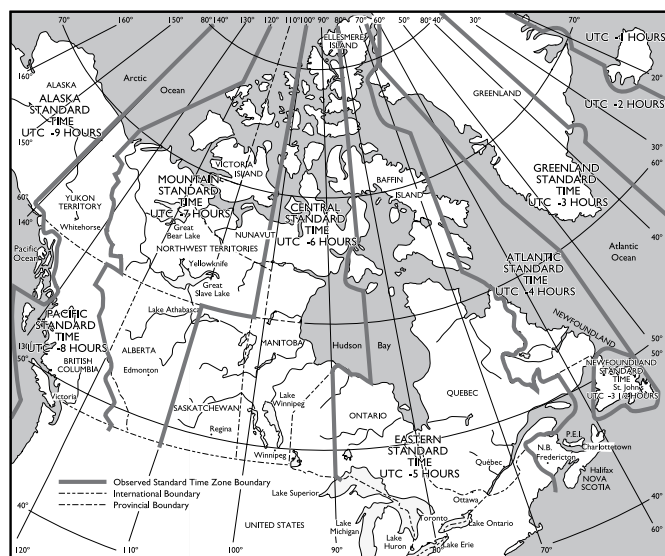

Chart provided by the Institute of National Measurement Standards, National Research Council, Canada (2011)

1.6.3 Time Zone

Where daylight saving time (DST) is observed in Canada, clocks are advanced one hour. Starting in 2007, DST is in effect from 02:00 local time on the second Sunday in March to 02:00 local time on the first Sunday in November. Locations that observe DST are indicated in the CFS and the WAS. See the Aerodrome/Facility Directory Legend of these publications under “Times of Operation”.

Time Zone	To Obtain Local Time
Newfoundland	UTC minus 3 1/2 hours (2 1/2 DT)
Atlantic	UTC minus 4 hours (3 DT)
Eastern	UTC minus 5 hours (4 DT)
Central	UTC minus 6 hours (5 DT)
Mountain	UTC minus 7 hours (6 DT)
Pacific	UTC minus 8 hours (7 DT)



1.7 NATIONALITY AND REGISTRATION MARKS

The nationality mark for Canadian civil aircraft consists of the capital letter “C” or two letters “CF”.

The registration mark of a Canadian registered aircraft shall be a combination of three or four capital letters as specified by Transport Canada Civil Aviation.

Each aircraft must carry its nationality and registration marks in the following places:

- (a) inscribed on a fireproof identification plate secured in a prominent position near the main entrance to the aircraft; and
- (b) painted on or affixed to the aircraft (see LRA 1.0).

1.8 SPECIAL EQUIPMENT TO BE CARRIED ON BOARD AIRCRAFT

Special equipment to be carried on board aircraft is located in AIR 2.14, 2.14.1, and AIR Annex 1.0.

1.9 MISCELLANEOUS INFORMATION

1.9.1 V Speeds

V_1	Critical engine failure recognition speed *
V_2	Takeoff safety speed
V_{2min}	Minimum takeoff safety speed
V_3	Flap retraction speed
V_a	Design safety speed
V_b	Speed for maximum gust intensity
V_c	Cruise speed
V_d	Diving speed
V_{df}/M_{df}	Demonstrated flight diving speed
V_f	Flap speed
V_{fe}	Maximum flap speed
V_h	Maximum level flight speed at maximum continuous power
V_{le}	Landing gear extended speed
V_{lo}	Maximum landing gear operation speed
V_{mc}	Minimum control speed with critical engine inoperative
V_{mo}/M_{mo}	Maximum operating limit speed
V_{mu}	Minimum unstick speed
V_{no}	Maximum structural cruising speed **
V_{ne}	Never exceed speed
V_r	Rotation speed
V_{ref}	Landing reference speed
V_s	Stalling speed or minimum steady controllable flight speed
V_{sl}	Stalling speed or minimum steady flight speed obtained in a specific configuration
V_{so}	Stalling speed or minimum steady flight speed in the landing configuration
V_x	Speed for best angle of climb
V_y	Speed for best rate of climb

* This definition is not restrictive. An operator may adopt any other definition outlined in the aircraft flight manual (AFM) of TC type-approved aircraft as long as such definition does not compromise operational safety of the aircraft.

** For older transport category aircraft V_{no} means normal operating limit speed.

1.9.2 Conversion Tables

MILLIBARS TO INCHES OF MERCURY

mb	0	1	2	3	4	5	6	7	8	9
	INCHES									
940	27.76	27.79	27.82	27.85	27.88	27.91	27.94	27.96	27.99	28.02
950	28.05	28.08	28.11	28.14	28.17	28.20	28.23	28.26	28.29	28.32
960	28.35	28.38	28.41	28.44	28.47	28.50	28.53	28.56	28.58	28.61
970	28.64	28.67	28.70	28.73	28.76	28.79	28.82	28.85	28.88	28.91
980	28.94	28.97	29.00	29.03	29.06	29.09	29.12	29.15	29.18	29.20
990	29.23	29.26	29.29	29.32	29.35	29.38	29.41	29.44	29.47	29.50
1000	29.53	29.56	29.59	29.62	29.65	29.68	29.71	29.74	29.77	29.80
1010	29.83	29.85	29.88	29.91	29.94	29.97	30.00	30.03	30.06	30.09
1020	30.12	30.15	30.18	30.21	30.24	30.27	30.30	30.33	30.36	30.39
1030	30.42	30.45	30.47	30.50	30.53	30.56	30.59	30.62	30.65	30.68
1040	30.71	30.74	30.77	30.80	30.83	30.86	30.89	30.92	30.95	30.98
1050	31.01	31.04	31.07	31.09	31.12	31.15	31.18	31.21	31.24	31.27

TEMPERATURE: DEGREES C TO DEGREES F

°C	°F	°C	°F	°C	°F	°C	°F	°C	°F	°C	°F	°C	°F	°C	°F
-45	-49.0	-33	-27.4	-21	-5.8	-9	15.8	3	37.4	15	59.0	27	80.6	39	102.2
-44	-47.2	-32	-25.6	-20	-4.0	-8	17.6	4	39.2	16	60.8	28	82.4	40	104.0
-43	-45.4	-31	-23.8	-19	-2.2	-7	19.4	5	41.0	17	62.6	29	84.2	41	105.8
-42	-43.6	-30	-22.0	-18	-0.4	-6	21.2	6	42.8	18	64.4	30	86.0	42	107.6
-41	-41.8	-29	-20.2	-17	1.4	-5	23.0	7	44.6	19	66.2	31	87.8	43	109.4
-40	-40.0	-28	-18.4	-16	3.2	-4	24.8	8	46.4	20	68.0	32	89.6	44	111.2
-39	-38.2	-27	-16.6	-15	5.0	-3	26.6	9	48.2	21	69.8	33	91.4	45	113.0
-38	-36.4	-26	-14.8	-14	6.8	-2	28.4	10	50.0	22	71.6	34	93.2	46	114.8
-37	-34.6	-25	-13.0	-13	8.6	-1	30.2	11	51.8	23	73.4	35	95.0	47	116.6
-36	-32.8	-24	-11.2	-12	10.4	0	32.0	12	53.6	24	75.2	36	96.8	48	118.4
-35	-31.0	-23	-9.4	-11	12.2	1	33.8	13	55.4	25	77.0	37	98.6	49	120.2
-34	-29.2	-22	-7.6	-10	14.0	2	35.6	14	57.2	26	78.8	38	100.4	50	122.0

CONVERSION FACTORS

To CONVERT	INTO	MULTIPLY BY
centimetres	inches	0.394
feet	metres	0.305
imperial gallon	U.S. gallon	1.201
imperial gallon	litres	4.546
inches	centimetres	2.540
inches of mercury	pounds per square inch	0.490
kilograms	pounds	2.205
kilograms per litre	pounds per imperial gallon	10.023
kilograms per litre	pounds per U.S. gallon	8.333
kilometres	nautical miles	0.540
kilometres	statute miles	0.621
litres	imperial gallon	0.220
litres	U.S. gallon	0.264
megapascals	pounds per square inch	145.14
metres	feet	3.281
nautical miles	kilometres	1.852
nautical miles	statute miles	1.152
newton	pounds	0.2248
pounds	kilograms	0.454
pounds	newtons	4.448
pounds per imperial gallon	kilograms per litre	0.0998
pounds per square inch	inches of mercury	2.040
pounds per square inch	megapascals	0.00689
pounds per U.S. gallon	kilograms per litre	0.120
statute miles	kilometres	1.609
statute miles	nautical miles	0.868
U.S. gallon	imperial gallon	0.833
U.S. gallon	litres	3.785

1.9.3 RVR Comparative Scale–Feet to Metres

RVR - FEET	RVR - METRES
500	150
600	175
700	200
1000	300
1200	350
1400	400
2600	800
4000	1200
5000	1500

2.0 SAFETY

2.1 AVIATION OCCUPATIONAL HEALTH AND SAFETY PROGRAM

2.1.1 General

The Transport Canada Aviation Occupational Safety and Health (OSH) Program began in 1987. This Program has recently been renamed the Transport Canada Aviation Occupational Health and Safety (AOH&S) Program. The main objective of the program is to ensure compliance with Part II of the *Canada Labour Code*. As an extended jurisdiction of the Department of Human Resources and Skills Development Canada (HRSDC— Labour Program), it is administered by Transport Canada, Safety and Security.

The corner-stone of the AOH&S Program is to ensure compliance with the purpose of Part II of the *Canada Labour Code*, i.e., “to prevent accidents and injury to health arising out of, linked with or occurring in the course of employment.” Transport Canada is responsible for the administration, enforcement and promotion of the Code as it applies to employees working on board an aircraft while in operation. The AOH&S Program position in this regard is that an aircraft is considered to be “in operation” anytime it is flying in Canada or abroad, as well as anytime the aircraft doors are closed and the aircraft is moving on the ground, under its own power, for the purposes of taking off or landing.

2.1.2 Refusal to Work in Dangerous Situations

Based on the *Canada Labour Code*, Part II, subsection 128(1), pilots have a legal right to refuse to work, if they have reasonable cause to believe that taking off constitutes a danger, or a potential danger, to themselves or others. Pursuant to subsection 122(1) of the Code,

“danger” means any existing or potential hazard or condition or any current or future activity that could reasonably be expected to cause injury or illness to a person exposed to it before the hazard or condition



can be corrected, or the activity altered, whether or not the injury or illness occurs immediately after the exposure to the hazard, condition or activity, and includes any exposure to a hazardous substance that is likely to result in a chronic illness, in disease or in damage to the reproductive system.

For pilots, refusals to work in dangerous, or potentially dangerous, situations could occur under a variety of different scenarios; for example, security issues on board aircraft; concerns about improperly packaged, loaded or secured cargo; pressures to complete flight on schedule; and deteriorating weather conditions.

Once a pilot has indicated they are refusing to work, both they and their employer have specific roles and responsibilities that have been established to assist them in working together to find a solution. Subsections 128(1) through 129(7) of the Code identify these employee and employer roles and responsibilities, as well as the role and responsibility of the Civil Aviation Safety Inspector—Occupational Health and Safety (CASI-OHS), should their intervention become necessary.

To protect an employee’s rights, section 147 of the Code states that no employer shall take, or threaten to take, any disciplinary action against an employee who has refused to work in a dangerous situation. It should also be noted that subsection 147.1(1) states that after all the investigations and appeals have been exhausted by the employee who exercised their rights to refuse dangerous work, the employer may take disciplinary action against that employee provided the employer can demonstrate the employee has willfully abused those rights.

2.1.3 Civil Aviation Safety Inspectors – Occupational Health and Safety (CASI-OHS)

CASI-OHSs in the Regions who report to their respective Commercial and Business Aviation managers are responsible for ensuring compliance with Part II of the *Canada Labour Code* and the *Aviation Occupational Safety and Health Regulations*. To ensure a 24-hr service to the aviation community, CASI-OHSs or an alternate may be reached either during the day at their work place or after working hours at the following numbers:

- Pacific Region: 604-666-5654
604-612-4944 (after working hours)
- Prairie and Northern Region:
 - Edmonton Office 780-495-5271
780-495-7726
1-877-992-6853 (after working hours)
 - Calgary Office 403-292-5051
403-292-5216
1-877-992-6853 (after working hours)
 - Winnipeg Office: 204-983-1394
1-877-992-6853 (after working hours)

- Ontario Region: 905-405-3294
905-612-6256
1-800-641-4049 (after working hours)
- Quebec Region: 514-633-3261
514-633-3722
514-633-3534 (after working hours)
- Atlantic Region: 506-851-3333
506-851-6561
506-851-6644
- Headquarters (only if a Regional Officer cannot be reached):
613-991-1271
613-990-1072
613-998-4705

They may also be reached at the following address:

Transport Canada (AARTH)
330 Sparks Street
Ottawa ON K1A 0N8

E-mail:jacques.servant@tc.gc.ca
E-mail:elizabeth.marston@tc.gc.ca
E-mail:martin.gravel@tc.gc.ca

2.1.4 Web Site

For additional information on the Transport Canada AOH&S Program, visit our Web site at < <http://www.tc.gc.ca/eng/civilaviation/standards/commerce-ohs-menu-2059.htm> >.

2.2 SYSTEM SAFETY NATIONAL PROGRAM

2.2.1 General

System Safety is responsible for monitoring and evaluating the level of safety within the National Civil Air Transportation System (NCATS) by:

- monitoring and evaluating all facets of the system;
- reviewing and analyzing accident and incident data, as well as other safety-related information;
- assessing risk and providing risk management advice;
- determining safety priorities;
- developing safety promotion to enhance the level of safety awareness, and to reduce the probability of injuries to persons or loss of resources; and
- preparing and coordinating emergency response to national or international emergencies affecting aviation.

For more information on the System Safety National Program and its activities, visit its Web site at <www.tc.gc.ca/CivilAviation/SystemSafety>.

2.2.2 Safety Intelligence

One of System Safety's objectives is to produce safety intelligence. This is information about hazards in the National Civil Air Transportation System (NCATS) that allows managers in Civil Aviation to understand the hazards and risks present in the elements of the system they oversee. Communication of safety intelligence enables the development of mitigation and prevention strategies that correctly match the nature of the hazards.

The Safety Evaluation and Standards Division communicates safety intelligence directly to other branches and by working with the Safety Promotion and Education Division to develop more extensive communication strategies. Functional specialists use their expertise to combine information from many sources to identify key risks and remedial actions and provide feedback on their intelligence needs. Some hazards or issues may be raised to the National Civil Aviation Safety Committee (NSASC) if they warrant national attention.

A key aspect of communications activities is to ensure that safety intelligence is recorded and understood throughout Civil Aviation so that system-wide risks are assessed and initiatives are not duplicated or opportunities missed.

Ultimately, the goal is the early detection of conditions that may later introduce hazards and increase the level of risk. This includes the regulator's role within the system and the way the regulator addresses identified hazards.

2.2.3 Minister's Observer and Technical Advisor Programs

Key aspects of obtaining safety intelligence are the Minister's Observer and Technical Advisor Programs. While it is the TSB mandate to advance transportation safety by conducting investigations into occurrences, the Minister's observer/technical advisor plays an essential role by:

- obtaining timely, factual information from an on-going investigation;
- advising the Minister of significant regulatory factors;
- identifying deficiencies that require immediate coordination of corrective actions;
- being TC's support to an aviation occurrence investigation; and
- providing safety intelligence to senior managers and the Minister to help support their decision making.

As a member of the International Civil Aviation Organization (ICAO), Canada enjoys certain rights and accepts certain responsibilities in relation to accidents either occurring in another State, or where another State has an interest in an accident that occurs in Canada.

These responsibilities are detailed in Article 26 of the ICAO convention, which imposes an obligation on the State in which the aircraft accident occurs, to institute an inquiry in accordance with ICAO procedures; and Article 37, which provides for the Standards and Recommended Practices (SARPS) for aircraft accident investigation. Annex 13 to the Convention on International Civil Aviation details these SARPS.

In the event of a foreign accident involving a Canadian-registered aircraft, or an aircraft or significant component manufactured in Canada, Canada has the right to appoint an accredited representative. Under Annex 13, this duty falls to the TSB. TC and other Canadian interests may appoint technical advisors to support the accredited representative.

In the event of a domestic occurrence, the Canadian Transportation Accident Investigation and Safety Board Act (CTAISB Act) contains provisions that permit a party of direct interest to participate as an observer in a TSB investigation if the Board determines that it is appropriate.

If the TSB decides not to investigate, in accordance with the CTAISB Act Chapter C-23.4 Section 14(2), TC can make a formal request to the TSB to investigate. TC would be liable to the Board for any reasonable costs incurred by the Board in their investigation.

The CTAISB Act, Chapter C-23.4 Section 14(4), also states:

"Nothing prevents ... a department from commencing an investigation into or continuing to investigate a transportation occurrence for any purpose other than that of making findings as to its causes and contributing factors, or from investigating any matter that is related to the transportation occurrence and that is not being investigated by the Board..."

In the event of an occurrence involving a Canadian civil aviation certificate holder, Civil Aviation must determine, on behalf of the Minister, as quickly as possible, whether or not the certificate holder continues to meet the certificate's conditions of issue.

2.2.4 Safety Communications and Partnerships

As part of Civil Aviation's larger risk mitigation strategy, System Safety communicates safety intelligence to promote the adoption of practices known to be effective at mitigating risk, and to educate the wider aviation community on current and emerging hazards.

Promotional and educational products are developed, as appropriate, to support System Safety programs and initiatives for the Canadian aviation industry. These programs and initiatives aim to enhance aviation safety awareness and accident prevention. For example, the Aviation Safety Letter (ASL), Civil Aviation's quarterly online newsletter, includes articles that address aviation safety from all perspectives, such as regulatory updates, safety insight derived from accidents and incidents, as well as information

tailored to the needs of maintenance and servicing personnel and aviation managers. The ASL is targeted at the entire aviation industry, but particularly at certificate holders, as well as holders of a valid pilot licence, permit, or a valid Canadian aircraft maintenance engineer (AME) licence. Readers can subscribe to the ASL e-Bulletin notification service and receive an e-mail announcing the release of each new issue of the ASL, with a link to the ASL Web page. To register for this service, please go to <www.tc.gc.ca/ASL> and follow the appropriate steps. Those who prefer a printed copy will be able to receive a print-on-demand version (black and white) through TC’s Publication Order Desk by calling 1-888-830-4911 or by e-mailing <MPSI@tc.gc.ca>.

Another safety communications and partnership initiative is the Canadian Aviation Executives’ Safety Network (CAESN). The CAESN was established in 2003 as an annual assembly of Canadian aviation leaders to continue responding to the multiple challenges facing civil aviation. For information on the CAESN and records of past meetings, visit <www.tc.gc.ca/eng/civilaviation/regserv/affairs-caesn-menu-1975.htm>.

3.0 TRANSPORTATION SAFETY BOARD OF CANADA

3.1 AVIATION SAFETY INVESTIGATION

The purpose of an aviation safety investigation into an aircraft accident or incident is to prevent a recurrence; it is not to determine or apportion blame or liability. The TSB, established under the *Canadian Transportation Accident Investigation and Safety Board Act*, is responsible for investigating all aviation occurrences in Canada involving civil aircraft registered both in Canada and abroad. A team of investigators is on 24-hr standby.

3.2 DEFINITIONS

“*aviation occurrence*” means

- (a) any accident or incident associated with the operation of an aircraft; and
- (b) any situation or condition that the Board has reasonable grounds to believe could, if left unattended, induce an accident or incident described in paragraph (a).

“*dangerous goods*” means dangerous goods as defined in the *Transportation of Dangerous Goods Act*.

“*reportable aviation accident*” means an accident resulting directly from the operation of an aircraft, where

- (a) a person sustains a serious injury or is killed as a result of
 - (i) being on board the aircraft,
 - (ii) coming into contact with any part of the aircraft or its contents, or
 - (iii) being directly exposed to the jet blast or rotor downwash of the aircraft;
- (b) the aircraft sustains damage or failure that adversely affects the structural strength, performance or flight characteristics of the aircraft and that requires major repair or replacement of any affected component part; or
- (c) the aircraft is missing or inaccessible.

“*reportable aviation incident*” means an incident resulting directly from the operation of an airplane having a maximum certificated take-off weight greater than 5 700 kg, or from the operation of a rotorcraft having a maximum certificated take-off weight greater than 2 250 kg, where

- (a) an engine fails or is shut down as a precautionary measure;
- (b) a transmission gearbox malfunction occurs;
- (c) smoke or fire occurs;
- (d) difficulties in controlling the aircraft are encountered owing to any aircraft system malfunction, weather phenomena, wake turbulence, uncontrolled vibrations or operations outside the flight envelope;
- (e) the aircraft fails to remain within the intended landing or take-off area, lands with all or part of the landing gear retracted or drags a wing tip, an engine pod or any other part of the aircraft;
- (f) any crew member whose duties are directly related to the safe operation of the aircraft is unable to perform the crew member’s duties as a result of a physical incapacitation that poses a threat to the safety of any person, property or the environment;
- (g) depressurization occurs that necessitates an emergency descent;
- (h) a fuel shortage occurs that necessitates a diversion or requires approach and landing priority at the destination of the aircraft;
- (i) the aircraft is refuelled with the incorrect type of fuel or contaminated fuel;
- (j) a collision, a risk of collision or a loss of separation occurs;

- (k) a crew member declares an emergency or indicates any degree of emergency that requires priority handling by an air traffic control unit or the standing by of emergency response services;
- (l) a slung load is released unintentionally or as a precautionary or emergency measure from the aircraft; or
- (m) any dangerous goods are released in or from the aircraft.

3.3 REPORTING AN AVIATION OCCURRENCE

3.3.1

Where a reportable aviation accident occurs and it has not yet been reported to the TSB, the pilot-in-command, operator, owner and any crew member of the aircraft involved shall report the following information to the Board as soon as possible thereafter and by the quickest means of communication available:

- (a) the type, model and nationality and registration marks of the aircraft;
- (b) the names of the owner, operator and, where applicable, the hirer of the aircraft;
- (c) the name of the pilot-in-command;
- (d) the date and time of the accident;
- (e) the last point of departure and the point of intended landing of the aircraft, including the date and time of the departure;
- (f) the location of the aircraft by reference to an easily defined geographical point, or by latitude and longitude;
- (g) the number of crew members, passengers and other persons that were killed or sustained serious injury;
- (h) a description of the accident and the extent of any resulting damage to the aircraft, the environment and other property;
- (i) a description of any dangerous goods on board, or released from, the aircraft; and
- (j) the name and address of the person making the report.

3.3.2

Where an aircraft is missing or inaccessible and the accident has not yet been reported to the TSB, the owner and the operator of the aircraft shall report the following information to the Board by the quickest means of communication available:

- (a) the type, model and nationality and registration marks of the aircraft;
- (b) the names of the owner, operator and, where applicable, the hirer of the aircraft;
- (c) the name of the pilot-in-command;
- (d) the last point of departure and the point of intended landing of the aircraft, including the date and time of the departure;
- (e) the date and time of the last known takeoff of the aircraft;
- (f) the last known position of the aircraft by reference to an easily defined geographical point, or by latitude and longitude, including the date and time of that position;
- (g) the names of crew members and passengers on board the aircraft;
- (h) the action being taken to locate, or gain access to, the aircraft;
- (i) a description of any dangerous goods on board the aircraft; and
- (j) the name and address of the person making the report.

3.3.3

Where a reportable incident occurs and the incident has not yet been reported to the TSB, the owner, operator, pilot-in-command, any crew member of the aircraft, and, where the incident involves a loss of separation or a risk of collision, any air traffic controller having knowledge of the incident shall report the following information to the Board as soon as possible thereafter and by the quickest means of communication available:

- (a) the type, model and nationality and registration marks of the aircraft;
- (b) the names of the owner, operator and, where applicable, the hirer of the aircraft;
- (c) the name of the pilot-in-command;
- (d) the date and time of the incident;
- (e) the last point of departure and the point of intended landing of the aircraft, including the date and time of the departure;

- (f) the location of the incident by reference to an easily defined geographical point, or by latitude and longitude;
- (g) the number of crew members, passengers and other persons that were killed or sustained serious injury;
- (h) a description of the incident and the extent of any resulting damage to the aircraft, the environment and other property;
- (i) a description of any dangerous goods on board, or released from, the aircraft; and
- (j) the name and address of the person making the report.

3.3.4

Any other incident indicative of a deficiency or discrepancy in the Canadian air transportation system may be reported in writing to the TSB. Sufficient details concerning the incident should be provided to enable the identification of action required to remedy the deficiency or discrepancy.

3.3.5

Reportable aviation accidents and incidents, and missing aircraft are to be reported to the Regional TSB office, using the telephone numbers listed in GEN 3.6. Alternatively, occurrences may be reported through a NAV CANADA ATS unit, which will forward the report to the appropriate TSB office.

For Canadian-registered aircraft operating outside of Canada, in addition to the reporting required by the state of occurrence, a report shall be made to the TSB Regional office nearest to the company's headquarters or, for private aircraft, nearest to the aircraft's home base.

3.4 PROTECTION OF OCCURRENCE SITES, AIRCRAFT, COMPONENTS AND DOCUMENTATION

3.4.1

- (1) Where a reportable accident or incident takes place, the owner, operator and any crew member shall, to the extent possible, and until otherwise instructed by a TSB investigator or except as otherwise required by law, preserve and protect any evidence relevant to the reportable accident or incident, including evidence contained in documents, except when taking necessary measures to ensure the safety of any person, property or the environment.

- (2) Where evidence relevant to a reportable accident or incident has to be interfered with pursuant to paragraph (1), the person directing, supervising or arranging the interference shall, to the extent possible in the circumstances, and prior to the interference, record the evidence by the best means available.

3.4.2

Where a reportable aviation accident occurs, the pilot-in-command, operator, owner and any crew member of the aircraft involved shall, to the extent possible, preserve and protect:

- (a) the aircraft or any component or contents thereof and the occurrence site until such time as an investigator otherwise authorizes;
- (b) the flight data and cockpit voice recorders and the information recorded thereon; and
- (c) all other records, documents and all materials of any kind pertaining to:
 - (i) the flight during which the accident occurred,
 - (ii) the crew members involved, and
 - (iii) the aircraft, its contents and components,

and shall surrender on demand the recorders, information, records, documents and materials referred to in (b) and (c) to an investigator.

3.4.3

Where a reportable aviation incident occurs, the pilot-in-command, operator, owner and any crew member of the aircraft involved shall, to the extent possible, preserve and protect:

- (a) the flight data recorders and the information recorded thereon; and
- (b) all other records, documents and materials of any kind pertaining to:
 - (i) the flight during which the incident occurred,
 - (ii) the crew members involved, and
 - (iii) the aircraft, its contents and components,

and shall surrender on demand the recorders, information, records, documents and materials referred to in (a) and (b) to an investigator.

3.5 SECURITAS PROGRAM

The SECURITAS program provides a means for individuals to report incidents and potentially unsafe acts or conditions relating to the Canadian transportation system that would not normally be reported through other channels. It should be noted that this multi-modal confidential safety reporting system replaces the Confidential Aviation Safety Reporting Program (CARSP).

Each report is assessed by SECURITAS analysts. When a reported concern is validated as a safety deficiency, the TSB normally forwards the information, often with suggested corrective action, to the appropriate regulatory authority, or in some cases, the transportation company, organization, or agency. No information will be released that could reasonably be expected to reveal the reporter's identity without the reporter's written consent.

SECURITAS is primarily concerned with unsafe acts and conditions relating to commercial and public transportation systems. To submit a report, write, fax, e-mail, or telephone SECURITAS at:

SECURITAS
 P.O. Box 1996
 Station B
 Gatineau QC J8Z 3Z2

Tel.: 1-800-567-6865
 Fax: 819-994-8065
 E-mail: securitas@tsb-bst.gc.ca

3.6 OFFICES OF THE TSB

HEADQUARTERS:

Place du Centre, 4th Floor
 200 Promenade du Portage
 Gatineau QC K1A 1K8

Toll-free (within Canada): 1-800-387-3557
 Toll: 819-994-3741
 Fax: 819-953-9586
 TTY: 819-953-7287
 E-mail: airops@tsb-bst.gc.ca

REGIONAL OFFICES (AIR)

TSB—Pacific

Regional Manager, TSB-AIR
 4-3071 Number Five Road
 Richmond BC V6X 2T4

Toll-free (within Canada): 1-800-387-3557
 Toll: 819-994-3741
 Fax: 604-666-7230
 E-mail: airnotifications.vancouver@tsb-bst.gc.ca

TSB—Western

Regional Manager, TSB-AIR
 17803 106A Avenue
 Edmonton AB T5S 1V8

Toll-free (within Canada): 1-800-387-3557
 Toll: 819-994-3741
 Fax: 780-495-2079
 E-mail: airnotifications.edmonton@tsb-bst.gc.ca

TSB—Central

Regional Manager, TSB-AIR
 335-550 Century Street
 Winnipeg MB R3H 0Y1

Toll-free (within Canada): 1-800-387-3557
 Toll: 819-994-3741
 Fax: 204-983-8026
 E-mail: airnotifications.winnipeg@tsb-bst.gc.ca

TSB—Ontario

Regional Manager, TSB-AIR
 23 East Wilmot Street
 Richmond Hill ON L4B 1A3

Toll-free (within Canada): 1-800-387-3557
 Toll: 819-994-3741
 Fax: 905-771-7709
 E-mail: airnotifications.toronto@tsb-bst.gc.ca

TSB—Quebec

Regional Manager, TSB-AIR
 185 Dorval Avenue, Suite 403
 Dorval QC H9S 5J9

Toll-free (within Canada): 1-800-387-3557
 Toll: 819-994-3741
 Fax: 514-633-2944
 E-mail: airnotifications.montreal@tsb-bst.gc.ca

TSB—Atlantic

Regional Manager, TSB-AIR
 150 Thorne Avenue
 Dartmouth NS B3B 1Z2

Toll-free (within Canada): 1-800-387-3557
 Toll: 819-994-3741
 Fax: 902-426-5143
 E-mail: airnotifications.dartmouth@tsb-bst.gc.ca

4.0 INDEX OF KEYWORDS

A

- Abbreviations – Aviation Forecasts MET 3.6
- Abbreviations and Acronyms..... GEN 5.2
- Abnormal Operation of Navigation Aids,
Pilot Reporting of COM 3.4
- ACA (Arctic Control Area), Position
Reporting Within RAC 12.6.6
- ACAS/TCAS..... RAC 12.16
- ACAS II and Transponder Equipage..... RAC 12.17.11
- ACA Track System.....RAC 12.7.1
- Accident site, Protection of GEN 3.4
- Accident reporting GEN 3.3
 - Confidential Incident Reporting
 - SECURITAS Program..... GEN 3.6
- Accuracy, Availability and Integrity
of Navigation Aids..... COM 3.3
- Acknowledgement of Clearances – VFR RAC 5.2
- Acronyms and Abbreviations..... GEN 5.2
- ADIZ (Air Defence Identification Zone)
..... RAC 2.13, 3.9, 12.8
- ADS WPR FANS 1/A (Automatic Dependent
Surveillance Waypoint Position Reporting) RAC 8.2
- Advance Notice of Intent in Minimum
Weather Conditions..... RAC 9.5
- Advisory Airspace..... RAC 2.8.6
- Advisory forecasts..... MET 3.9.1
- Aerobatic Flight.....RAC 1.11
- Aerodromes and airports AGA 2.0
 - ARCAL (Aircraft Radio Control
of Aerodrome Lighting) AGA 7.18
 - ATF (Aerodrome Traffic Frequency).RAC 4.5.5, 4.5.6
 - AuthorityAGA 1.1.1
 - Beacon..... AGA 7.2
 - CertificationAGA 2.3
 - Design Criteria, Runway..... AGA 3.1
 - Directory AGA 1.3
 - DND (Snow Removal and Ice Control) AGA 1.1.5
 - Lighting..... AGA 7.0
 - Maintenance
 - Transport Canada..... AGA 1.1.5, 2.3.3
 - Military AGA 1.1.5, 9.0, FAL 2.2.3
 - Obstacle Charts (ICAO Type A) MAP 3.6
 - Operator Responsibilities.....AGA 2.3.4
 - PNR (Prior Notice Required).....AGA 2.2
 - PPR (Prior Permission Required)AGA 2.2
 - Private-use CertificateAGA 2.2
 - Public-use CertificateAGA 2.2
 - Registration AGA 2.1
 - Runway Characteristics AGA 3.0
 - TAF (Forecasts).....MET 3.9
 - From AWOS Sites MET 3.9.4
 - National Variations MET 3.9.2
 - Uncontrolled Procedures (IFR).....RAC 9.13
 - Use, International Flights..... AGA 1.2, FAL 2.2.2
- Aeromedical Factors AIR 3.2
- Aeronautical

- AFS (Aeronautical Fixed Service) COM 6.1
- AFTN (Aeronautical Fixed
Telecommunications Network) COM 6.1.2
- AuthorityGEN 1.1.1
- Charts for Visual Flight MAP 7.3
- Ground Lights AGA 1.4
- Aeronautical Information GEN 1.1
 - AIRAC Canada MAP 6.5
 - AIS (Services)..... GEN 1.1.2
 - Broadcast Service RAC 1.1.3
 - Canada Flight Supplement MAP 3.4
 - Charts and Publications for International
Flights..... MAP 8.0
 - Circular..... MAP 6.3
 - Collection MAP 4.0
 - ICAO Type A Charts..... MAP 3.6
 - IFR..... MAP 3.0
 - In-flight Information MAP 1.3
 - Manual (TC AIM).....GEN 1.1.3
 - NOTAM MAP 5.0
 - Procurement of Charts and PublicationsMAP 7.0
 - Publication, Aeronautical Information
(AIP Canada).....GEN 1.1.3
 - Publication Revision Cycles..... MAP 3.5
 - VFR..... MAP 2.0
- Aeronautical Study, Requirements for an AGA 6.3
- Aeronautical Terms, Glossary..... GEN 5.1
- Aeronautics Act and Canadian Air Regulations,
– Legislative Index..... GEN 5.3
- Aiding Persons in Distress SAR 2.4
- AIP Canada (ICAO)
 - AIC (Aeronautical Information Circular) ... MAP 6.3
 - Content GEN 1.1.3
 - Co-ordinator GEN 1.1.3
 - Enquiries GEN 1.1.3
 - Supplements MAP 6.2
- AIRAC Canada MAP 6.5
- Air Navigation Service Charges..... FAL 3.2
- Air Routes and Airways Designation COM 5.5
- Air Time and Flight Time AIR 4.1
- Air Traffic and Advisory Services RAC 1.1
- Air Traffic Services, Services Other Than RAC 1.2
- Aircraft
 - Accident Investigation..... GEN 3.1
 - Aircraft Identification, Marking, Registration
and Insurance LRA 4.0
 - Airworthiness..... LRA 5.0
 - Airworthiness ANNEX LRA 9.0
 - ARCAL (Radio Control of
Aerodrome Lighting) AGA 7.18
 - Categories..... RAC 9.21
 - Change of Ownership –
Canadian-Registered..... LRA 4.4
 - Contamination (Frost, Ice or Snow)
 - In Flight AIR 2.12.3
 - On ground AIR 2.12.2
 - Design Requirements LRA 5.2
 - Emergency Assistance SAR 4.0
 - First Aid Kits on Privately Owned

- and Operated Aircraft..... AIR 4.13
- Identification LRA 4.2
- Import/Export LRA 4.6, 4.7
- Liability Insurance LRA 4.8
- NAT RVSM Aircraft Approvals RAC 11.23.4
- Nationality and Registration Marks..... GEN 1.7, LRA 4.3
- Navigational Equipment, Interference with COM 3.1.2
- Operations – Uncontrolled Aerodromes RAC 4.5
- Public Health Measures Applied to Aircraft..... FAL 2.4
- Registration, Initial LRA 4.5
- Rescue and Fire Fighting (ARFF)..... AGA 8.0
- Special Equipment to be Carried on Board Aircraft..... GEN 1.8
- Speed Limit RAC 2.5.2
- Technical Records LRA 5.6.3
- Aircraft Contamination in Flight AIR 2.12.3
- Aircraft Contamination on the Ground..... AIR 2.12.2
- Aircraft Rescue and Fire Fighting (ARFF)..... AGA 8.0
 - Hours of Availability..... AGA 8.2
 - Classification System..... AGA 8.3
 - ARFF Standby Request AGA 8.4
- Aircraft Movement Surface Condition Report (AMSCR) AIR 1.6.4
- Aircraft Parachute System GEN 5.1
- AIREP (Meteorological Report) MET 1.1.6, RAC 11.14
- Airmanship..... AIR 1.1
 - Flight Operations AIR 2.0
 - Low Flying AIR 2.4
- AIRMET..... MET 1.3.6, 3.4
- Arrival Procedures – IFR RAC 9.0
- Airport
 - AAS (Advisory Service)..... RAC 1.1.3
 - ASDE (Surface Detection Equipment) COM 3.14
 - Airport Radio (APRT RDO)..... RAC 1.2.2
 - Bird Hazard AGA 1.1.6, RAC 1.15
 - Certificate..... AGA 2.4
 - Certification AGA 2.3, 2.3.5, 2.3.6
 - Operational Guidance Signs AGA 5.8.2
 - Operations RAC 4.0
 - Controlled Airports, Departure Procedures RAC 4.2
 - Snow Removal and Ice Control..... AGA 1.1.5
 - Uncontrolled Aerodromes..... RAC 4.5
 - Zoning Regulations AGA 4.3
- Airside Guidance Signs..... AGA 5.8
- Air Navigation Service Charges..... FAL 3.2
- Airspace Classification RAC 2.8
 - Advisory RAC 2.8.6
 - Altitude Reservations RAC 2.9.1
 - Canadian Domestic/Northern and Southern Domestic..... RAC 2.2, Fig. 2.1
 - Classification of RAC 2.8
 - CMNPS, RNPC and CMNPS Transition RAC Fig. 12.1
 - CMNPS (Canadian Minimum Navigation Performance Specifications) RAC 12.5
 - High and Low Level..... RAC 2.3
 - High Level Controlled..... RAC 2.6
 - Joint Use RAC 2.8.6
 - Low Level Controlled RAC 2.7
 - NAT MNPSA (North Atlantic Minimum Navigation Performance – Specifications) Between FL285 and FL420 RAC Fig.11.2, RAC 11.22
 - Other Divisions RAC 2.9
 - Requirements and Procedures RAC 2.0
 - Restricted RAC 2.8.6
 - Southern, Northern and Arctic Control Areas RAC Fig. 2.4
 - Structured..... RAC 12.3
- Airways and Air Routes Designation COM 5.5
- Airways, low level – LF/MF, VHF/UHF RAC 2.7.1
- Airworthiness
 - Aircraft..... LRA 5.0
 - ANNEX LRA 5.8
 - Annual Airworthiness Information Report LRA 5.5
 - Flight Authority..... LRA 5.3
- Airworthiness Directives (ADs) LRA 5.7
 - Availability of..... LRA 5.7.2
 - Schedule and Compliance Records LRA 5.7.3
- AIS (Aeronautical Information Services) GEN 1.1.2
- Alcohol AIR 3.11
- Alerting Devices and Circuit Breakers AIR 4.11
- Alphabet, Phonetic COM 5.4
- Alternate Aerodrome, Requirements for IFR Flight RAC 3.14
- Altimeter
 - Abnormally High Pressure Weather Conditions..... RAC 12.12, AIR 1.5.9
 - Calibration of RAC Fig. 9.1, AIR 1.5.2
 - Dwindraft and Turbulence AIR 1.5.7
 - Effect of Mountains AIR 1.5.6
 - Incorrect Setting AIR 1.5.3
 - Major Errors of..... AIR 1.5.4
 - Pressure AIR 1.5
 - Pressure Drop..... AIR 1.5.8
 - Setting Region..... RAC 2.10, Fig. 2.10
 - Standard Pressure Region RAC 2.11, Fig. 2.10, AIR 1.5.5
 - Temperature Correction..... RAC Fig. 9.1, AIR 1.5.4
- Altitude
 - And Direction of Flight..... RAC 8.7.2
 - Area Minimum Altitude (AMA) RAC 8.7.1
 - Correction Chart RAC Fig. 9.1
 - IFR Minimum RAC 8.6, 8.7.1
 - Minimum Holding RAC 10.7
 - Reservations..... RAC 2.9.1
 - Cruise Climbs and Altitude Reports..... RAC 11.18
- Animals and Plants
 - Requirements for Importation FAL 2.5
- Anti-icing Additives, Fuel..... AIR 1.3.3
- Appeals – Transportation Appeal Tribunal of Canada (TATC) LRA 6.5
- Approach
 - Ban RAC 9.19.2

- Contact RAC 9.6.1
- From an Intermediate FixRAC 9.16
- Lighting Systems – HIAL, MALSR..... AGA 7.5.1
- LIAL, ODALS, MALSF..... AGA 7.5.2
- PAPI..... AGA 7.6.3
- PAR (Precision Radar).....COM 3.14, RAC 9.8.4
- Position Reports – Controlled Airports RAC 9.9
- Slope Indicator Systems
 - EWH (Eye-to-Wheel Height)..... AGA 7.6
- Straight-in.....RAC 9.15
- VASIS..... AGA 7.6.2
- Visual RAC 9.6.2
- Approach Procedures
 - with Vertical Guidance (APV).....COM 3.16.5
- Apron Advisory Service..... RAC 1.2.4
- ARCAL (Aircraft Radio Control of
 - Aerodrome Lighting) AGA 7.18
- Arctic RadioRAC 1.1.5
- Area Navigation (RNAV)COM 3.14
 - Equipment Failure Procedures RAC 12.4.6
 - Fixed RNAV Routes..... RAC 12.6.4
 - Preferred IFR Routes
 - (Including RNAV)..... RAC 12.6.3
- Areas
 - Gander Oceanic Control RAC Fig. 11.1
 - Mountainous.....RAC 2.12, Fig. 2.11
 - RVSM Transition Area.....RAC Fig. 12.3
 - Southern, Northern and Arctic
 - Control AreasRAC Fig. 2.4
 - Transition RAC 2.7.5
- Arrester Cables, Military Aircraft AGA 9.1
- Arrival
 - Procedures – Controlled Airports..... RAC 4.4
 - Traffic Circuit Procedures
 - Uncontrolled Aerodromes, VFR RAC 4.5.2
 - Report – ContentsRAC 3.12.1
- ASDA (Accelerate – Stop Distance Available)AGA 3.8
- ATC (Air Traffic Control)
 - Assignment of Altitudes RAC 8.7
 - Clearances, Instructions and Information RAC 1.7
 - Flight Planning RAC 12.4.4, 12.5.5
 - Flight Priority RAC 1.8
 - Parallel Offset Procedures RAC 12.2
 - RNAV/DME Distance..... RAC 12.4.5
 - RNPC (Required Navigation
 - Performance Capability)..... RAC 12.4
 - Special Procedures RAC 12.0
- ATFM (Air Traffic Flow Management)..... RAC 12.9
- ATIS (Automatic Terminal
 - Information Service) RAC 1.3, 4.2.1
 - BroadcastsRAC 1.3, 7.2, 9.1
 - METAR AUTO/SPECI
 - AUTO Reports MET 3.15.5
- ATS Reports
 - Possible Contravention of the *Canadian Air

 - Regulations (CARs) RAC 1.13*
- Automatic Landing (Autoland) Operations
 - COM 3.13.1, AIR 2.15

- Aviation
 - Automated Reports – Other MET 3.15.6
 - Document Booklet LRA 1.2
 - Fuels AIR 1.3
 - Language Proficiency LRA 1.3
 - Medical Review Board.....LRA 2.4
 - METAR (Routine Weather Report) MET 3.15
 - Notice MAP 6.4
 - Occurrence, Reporting an..... GEN 3.3
 - RecreationalAIR 4.7 to 4.10
 - Weather Briefing Service
 - (AWBS)MET 1.1.3, RAC 1.1.3
 - Weather Information Service
 - (AWWS) MET 1.1.3
 - Weather Reports/ChartsMET 3.2.2, 3.2.3
- Aviation Safety – Transport Canada Web SiteGEN 2.2.4
- AWOS (Automated Weather
 - Observation Systems) MET 1.2.4, 3.15.5
 - actual weather information/
 - reports/charts.....MET 1.2.4
 - METAR AUTO/SPECI AUTO Reports... .MET 3.15.5

B

- Ballistic Parachute SystemRAC 3.16.9
- Balloon Operations, Manned Free AIR 4.7
- Barometric Vertical Navigation
 - (BARO VNAV)
 - GPS Approaches COM 3.16.4.5.1
- Bars
 - Stop..... AGA 7.14
- Bay, TurnaroundAGA 3.4
- Beacons
 - Aerodrome..... AGA 7.2
 - Fan MarkerCOM 3.11
- Bearing Strength, Runway and Taxiway AGA 3.10
- Beaufort Wind Scale.....MET 2.6, Table 1
- Bird Hazard Control, Airport.....AGA 1.1.6, RAC 1.15
- Bird/Wildlife Strike Report RAC Fig. 1.2
- Birds, Migratory..... RAC 1.15.2, GEN 4.6
- Blood Donation.....AIR 3.14
- Boundary Markers, Aerodromes..... AGA 5.1

C

- Cable Span Marking, Suspended AGA 6.7
- Call Signs COM 5.8
 - Air Carriers COM 5.8.1
 - Ground Stations COM 5.8.2
 - MEDEVAC..... COM 5.8.1
 - Private Civil Registration..... COM 5.8.1
 - RCO..... COM 5.8.3
- Canada
 - Canadian Government Publishing..... MAP 7.2
 - Flight SupplementMAP 3.4, 7.3
 - Charts and Publications
 - Individual PurchasesMAP 7.3
 - Subscriptions.....MAP 7.3
 - Shipping Act, extract from..... SAR 4.9, AIR 2.11.1

Canadian Aviation Regulation Advisory Council (CARAC).....	LRA 7.0		
<i>Canadian Aviation Regulations (CARs)</i>			
..... COM ANNEX A 1.0, COM ANNEX B 2.0, 3.1, RAC ANNEX 2.0	LRA ANNEX 5.8		
– Legislative Index.....	GEN 5.3		
Canadian Domestic Airspace	RAC 2.2		
Canadian Domestic Routes	RAC 12.6		
– Canadian Track Structures	RAC 12.7		
Canadian Minimum Navigation Performance Specifications (CMNPS)			
– Air-to-Ground Communications	RAC 12.5.7		
– Airspace	RAC 12.5		
– Certification	RAC 12.5.3		
– Flight Planning.....	RAC 12.5.5		
– Navigation Capability While Operating Within CMNPS Airspace, Partial or Complete Loss of	RAC 12.5.6		
– Transition Airspace	RAC 12.5.2		
Canadian Runway Friction Index (CRFI)	AIR 1.6		
– Coefficients	AIR 1.6.2		
– Description and Method of Measurement ..	AIR 1.6.3		
Canadian Type Certificate	LRA 5.2.2		
CANPASS – Private Aircraft Program.....	FAL 2.3.3		
Carbon Monoxide	AIR 3.2.3		
Carburetor Icing	AIR 2.3		
Cargo Restraint.....	AIR 4.4		
CAVOK, Use of Term	RAC 1.4		
Central Monitoring Agency (CMA).....	RAC 11.23.5		
Certificate			
– Airport.....	AGA 2.4		
– Noise Compliance	LRA 5.3.5		
Certificate of Airworthiness (C of A)			
– Special	LRA 5.3.2, 5.3.3		
Certification			
– CMNPS	RAC 12.5.3		
– Of Aerodromes.....	AGA 2.1		
– Of Airports.....	AGA 2.3, 2.3.5, 2.3.6		
– RNP Aircraft	RAC 12.4.2		
Channel Spacing, VHF Communication			
Frequencies.....	COM 5.3		
Charges for Customs Services	FAL 3.3		
Charter Flight Airport Facilities Reservations	FAL 2.2.2		
– En Route, Low Altitude/High Altitude			
– Products	MAP 3.2		
Charts			
– Aerodrome Obstacle – ICAO Type A	MAP 3.6		
– Aeronautical, for Visual Flight	MAP 7.3		
– En Route, Low Altitude/High Altitude			
– Prices	MAP 7.3		
– Index of Aerodrome Obstacle Charts			
– ICAO Type A.....	MAP 3.6.2		
– Index to Canadian Aeronautical	MAP 2.2		
– Pavement Load Rating	AGA 3.10.1		
– Procurement – Individual and Subscription ..	MAP 7.3		
– Publication Revision Cycles.....	MAP 3.5		
– Publications – International Flights.....	MAP 8.0		
– Procurement of Aeronautical	MAP 7.0		
– Terminal Area	MAP 3.3.1		
– Updating Data	MAP 2.4		
– Updating of Canadian Aeronautical	MAP 2.3		
– Upper Level – Actual, Forecast (PROG)	MET 3.12		
Checklists, Pilot Vital Action.....	AIR 1.2		
Circling Minima and Procedures	RAC 9.23, 9.24		
Circuit Breakers and Alerting Devices	AIR 4.11		
Circuit			
– Controlled Aerodromes.....	RAC 4.3		
– Uncontrolled Aerodromes.....	RAC 4.5		
Circular, Aeronautical Information.....	MAP 6.3		
CIRVIS Reports, Vital Intelligence Sightings....	RAC 1.12.2		
Civil Aviation Complaint Filing Procedures.....	LRA 8.0		
Civil Aviation Contingency Operations (CACO)..	GEN 6.0		
– Headquarters Operations.....	GEN 6.2		
– Accident, Occurrence, or Incident Reporting ..	GEN 6.3		
Civil Twilight, Morning and Evening	GEN 1.6.2		
Class			
– A Airspace	RAC 2.8.1		
– B Airspace.....	RAC 2.8.2		
– C Airspace.....	RAC 2.8.3, 5.8		
– D Airspace	RAC 2.8.4		
– E Airspace	RAC 2.8.5		
– F Airspace	RAC 2.8.6		
– G Airspace	RAC 2.8.7, 8.10		
Clean Aircraft Concept	AIR 2.12.2		
Clear Air Turbulence (CAT),			
Avoidance of.....	MET 2.2, AIR 2.10		
Clearance(s)			
– Delivery.....	RAC 4.2.2		
– “Hold/Hold Short”	RAC 4.2.5		
– IFR.....	RAC 7.4		
– Landing	RAC 4.4.3		
– Limit	RAC 8.10		
– Leaving or Entering Controlled Airspace	RAC 8.9		
– Oceanic Clearance Delivery	RAC 11.8.3		
– Pilot Immunity from Enforcement Action for Deviating from	RAC 12.16.6		
– Resolution Advisory (TCAS/ACAS)	RAC 1.7		
– Tower Frequency, Release from.....	RAC 4.2.9		
Clearances Instructions and Information			
from the ATC	RAC 1.7, 6.1		
Clearway, Definition	AGA 3.7		
Clock Position System (Radar Traffic Information)			
.....	RAC 1.5.3		
Closed Markings – Runway, Taxiway, Heliports	AGA 5.6		
Cloud Heights	MET 1.1.5, 3.13		
CMNPS Airspace	RAC 12.5		
Code, Morse	COM 5.4		
Collision Avoidance			
– Right of Way, Regulations	RAC 1.10		
– Use of Landing Lights.....	AIR 4.5		
Communications			
– AFS (Aeronautical Fixed Services).....	COM 6.1.1		
– Air-to-Air	COM 5.13.3		
– Air-to-Ground, CMNPS	RAC 12.5.7		
– Air-to-Ground Service, International	COM 6.2		
– Aviation Weather Information Service (AWIS)			
.....	MET 1.1.3		
– Checks	COM 5.10		

- Emergency Communications and Security COM 5.11, RAC 2.13
- Failure (VFR)..... RAC 4.4.8, 6.3.2.2
- Fixed Telecommunications Service RAC 1.1.3
- Frequency 5680 kHz, Use of..... COM 5.14
- General Information COM 1.0
- Initial Contact..... RAC 4.4.1, 9.9
- Language..... COM 5.2, COM ANNEX A 1.0
- Location Indicators COM 2.0
- Navigation Equipment, Reporting
 - Malfunction of..... RAC 6.3.3
- Paid Communications Service RAC 1.1.3
- Private Navigation Aids COM 3.1.1
- Provision of Services COM 1.3
- Readability scale COM 5.10
- Radiocommunication Regulations..... COM 5.9
- Radio Navigation Aids..... COM 3.0
- Responsible Authority..... COM 1.2
- Satellite Voice..... COM 5.11
- Selective Calling System (SELCAL)..... COM 6.4
- Strength Scale COM 5.10
- Summary of Services RAC 1.2.3
- Use of MF and ATF RAC 4.5.6
- VFR Procedures at Uncontrolled Aerodromes with MF and ATF areas RAC 4.5.7
- VHF Coverage in the Canadian Northern Airspace COM 6.6.3
- VHF Coverage in the NAT Region..... COM 6.6.4
- Weather Radar Network (EC/DND)..... MET 3.16
- Community Aerodrome Radio Stations (CARS)..... RAC 1.2.2
- Confidential Incident Reporting
 - SECURITAS Program..... GEN 3.6
- Conservation Reindeer, Caribou, Moose and Muskoxen RAC 1.14.3
- Contact and Visual Approaches RAC 9.6
- Contamination of Aircraft (Frost, Ice or Snow)
 - In Flight..... AIR 2.12.3
 - On Ground..... AIR 2.12.2
- Control Transfer
 - IFR Units to Towers RAC 9.10
- Controlled Airports
 - Approach Position Reports RAC 9.9
 - Arrival Procedures RAC 4.4
 - Initial Clearance..... RAC 4.4.2
 - Landing Clearance RAC 4.4.3
 - Operations on Intersecting Runways..... RAC 4.4.9
 - Private Advisory Stations RAC 1.2.3
 - Sequential Operations RAC 4.4.9
 - Simultaneous Operations RAC 4.4.9
 - Traffic Circuits..... RAC 4.3
- Controlled Airspace..... RAC 2.5
 - Area Extensions RAC 2.7.2
 - Clearances
 - Leaving or Entering RAC 8.9
 - Control Zones..... RAC 2.7.3
 - High Level..... RAC 2.6
 - Low Level..... RAC 2.7
 - Low Level Airways – LF/MF, VHF/UHF RAC 2.7.1
 - Transition Areas RAC 2.7.5
 - Use of Controlled Airspace by VFR Flights RAC 2.5.1
- Controlled VFR (CVFR) Procedures RAC 5.6
- Conversion Tables..... GEN 1.9.2
- Correction Card System MAP 4.2
- CRFI AGA 1.1.4, AIR 1.6
- Cross Country Instrument Training Flights..... RAC 3.11
- Crosswind Landing Limitations
 - Light Aircraft AIR 2.2
- Cruise Climbs and Altitude Reports RAC 11.18
- Cruising Altitudes and Flight Levels RAC 2.3.1
- Customs
 - Agriculture FAL 1.2
 - CANPASS – Private Aircraft Program FAL 2.3.3
 - Charges for Customs Services..... FAL 3.3
 - Clearance of Aircraft, Documentary Requirements
 - Commercial Flights..... FAL 2.2
 - Private Flights FAL 2.3
 - Designated Authorities..... FAL 1.2
 - Documentary Requirements for Customs Clearance of Aircraft..... FAL 2.3.3
 - Fees and Charges..... FAL 3.0
 - Immigration FAL 1.2
 - Public Health Measures and Requirements for Passports and Visas FAL 2.2.4, 2.2.5, FAL 2.4
 - Violations, Penalties for FAL 3.4

D

- Dangerous Goods
 - Transportation by Air..... RAC ANNEX 3.0
- Dangerous Situations
 - Refusal to Work GEN 2.1.2
- Date – Time Group GEN 1.6.1
- Day Markings of Obstructions..... AGA 6.4
- Declared Distances..... AGA 3.8
- Decompression Sickness AIR 3.5
- Defence – ADIZ (Air Defence Identification Zone)..... RAC 2.13, 3.9, 12.8
 - Flight Plans..... RAC 3.9
- Departure(s)
 - Approach and Alternate Minima RAC 9.18
 - Non-radar RAC 4.1.1
 - Procedures – Controlled Airports..... RAC 4.2
 - RONLY Aircraft..... RAC 4.2.12
 - Radar RAC 4.1.1
- Design Eye Reference Point AIR 4.12
- Designated Mountainous Regions
 - in Canada RAC Fig. 2.11
- Dial-up RCO..... RAC 1.1.4
- Disorientation AIR 3.9
- Displaced
 - Runway Threshold Lighting AGA 7.9
 - Thresholds..... AGA 3.3
 - Threshold Markings AGA 5.4.1
- Ditching AIR 2.11.2
- DME (Distance Measuring Equipment) COM 3.7
 - Intersections, Minimum En-Route
 - Altitude..... RAC 8.7.1.1

- Procedures (Holding Patterns)..... RAC 10.8
- DME-DME (RHO-RHO) SystemCOM 3.14.2
- DND and Civil High Arctic AerodromesFAL 2.2.3
- Downed Aircraft Procedures SAR 4.8
- Downdraft and Turbulence.....AIR 1.5.7
- Drugs AIR 3.12
- Dry Ice – Safety Precautions AIR 3.16
- DUATS (Direct User Access Terminal System)
..... MET 1.1.4, RAC 3.4.2

E

- Electronic Devices on Board Aircraft,
Portable Passenger-operatedCOM Annex B 1.0
- ELT (Emergency Locator Transmitter).....SAR 3.0
 - Accidental TransmissionsSAR 3.7
 - Categories..... SAR 3.2
 - Downed Aircraft Procedures SAR 4.8
 - Flight Planning
(Supplementary Information).....RAC 3.16.9
 - Installation and Maintenance Requirements.. SAR 3.3
 - Operating Instructions (Emergency Use)..... SAR 3.5
 - Operating Instructions (Normal Use)..... SAR 3.4
 - Schedule of Requirements to Carry an ELT ...SAR 3.9
 - Signal, Maximizing the..... SAR 3.6
 - Testing Procedures SAR 3.8

Emergency

- Action by the Pilot during Emergency
Conditions SAR 4.2
- Assistance..... SAR 4.0
- Communications and Security... COM 5.11, RAC 2.13
- Declaring an RAC 6.3.1, SAR 4.1
- Lighting, Aerodrome.....AGA 7.17
- Locator TransmitterSAR 3.0
- Monitoring of Emergency Frequency
121.5 MHz.....COM 5.12
- Procedures, Downed Aircraft..... SAR 4.8
- Procedures for Signaling Vessels..... SAR 2.4
- Radio Frequency Capability SAR 4.6
- Transponder Alerting..... SAR 4.4

Emergency Equipment

- Flight Planning (Supplementary Information)
.....RAC 3.16.9
- Operations Over Sparsely Settled Areas AIR 2.14
- Operations Over WaterAIR 2.11.3

Emergency Security Control of Air Traffic

- (ESCAT)..... RAC 12.8.2

English, Use of in Communications

- COM 5.2, COM ANNEX A 1.0

- En-Route Procedures – VFR RAC 5.0

- En Route ChartsMAP 7.3

- Entry, Transit and Departure of Aircraft FAL 2.0

- Commercial Flights..... FAL 2.2
- Designated Authorities..... FAL 1.2
- Private Flights FAL 2.3

Equipment

- COM/NAVRAC 3.16.4
- RNAV RAC 9.2.2
- RNAV Equipment Failure Procedures..... RAC 12.4.5
- Surveillance (SSR) (Canadian and ICAO)..RAC 3.16.4

- ESCAT RAC 12.8.2
- Examinations, Use of Hand-held Calculators
or Computers for Written..... LRA 3.8
- Experimental Test Flights, Conduct of..... AIR 4.2
- Explosions and Fires..... AIR 1.3.4
- Export of Aircraft..... LRA 4.7
- Eye Reference Point, Design AIR 4.12

F

Facilitation

- Designated Authorities..... FAL 1.2
- General Information..... FAL 1.0, 1.1

- FANS 1/A ADS WPR..... RAC 8.2

- FatigueAIR 3.10

- FD (Upper Level Wind
and Temperature Forecasts) MET 3.11

Fees

- Airport..... FAL 3.1
- Charges for Customs Services FAL 3.3
- Telecommunications and En-Route
Facilities Services COM 6.5

- Final Approach Fix (FAF)..... RAC 9.19.2

- FIR (Flight Information Regions) RAC Fig. 2.3, 2.4

- Fire Detection – Northern Areas RAC 1.12.4

Fire Extinguishers

- For Use in Aircraft..... AIR 1.4
- Types of..... AIR 1.4.3

- Fire Fighting, Aircraft Rescue and (ARFF)..... AGA 8.0

- ARFF Hours of Availability AGA 8.2

- Classification System..... AGA 8.3

- ARFF Standby Request AGA 8.4

- Discreet Communication AGA 8.5

- Fires and Explosions AIR 1.3.4

- Fires, Classification of..... AIR 1.4.2

First Aid Kits on Privately Owned

- and Operated Aircraft..... AIR 4.13

Fitness

- Medically Fit LRA 1.9.2

- Unfit AssessmentLRA 1.9.4

Flight Level Allocation Scheme (FLAS),

- RVSMRAC 11.21.3

Flight(s)

- AerobicRAC 1.11

- AFS (Aeronautical Fixed)

- Airmanship AIR 1.0

- Authority LRA 5.3

- Definitions flight experience LRA 1.5

- Experimental Test AIR 4.2

- Fuel Requirements RAC 3.13

- Fuel, Sufficient Amount,
IFR/VFR Flights..... RAC 3.13.1, 3.13.2

- In Rain..... AIR 2.5

- Information Regions (FIR)RAC Fig.2.3, RAC 2.4

- Information Service RAC 1.1.1, 1.1.2

- International Flights..... COM 6.0, 6.1, 6.1.2

- Itineraries RAC 3.6

- Itinerary form, Composite IFR/VFR/
IFR Sample..... RAC Fig. 3.1

- Military Flight Advisory Unit (MFAU).....RAC 1.1.6

- Mountainous Regions RAC 2.12, AIR 2.13
- Operations – Airmanship..... AIR 2.0
- Operations in Volcanic Ash AIR 2.6
- Operations in Winter AIR 2.12
- Operations – Mountainous Regions
..... RAC 2.12, AIR 2.13
- Operations on WaterAIR 2.11
- Other InformationRAC 3.16.8
- Permit LRA 5.3.4
- Photographic Survey RAC 12.14
- Plan Service.....RAC 1.1.3
- PlanningRAC 3.0, 12.5.4, SAR 2.0
- Priority RAC 1.8
- Temporary Restrictions – Forest Fires..... RAC 2.9.2
- Time / Air Time AIR 4.1
- Transoceanic, General Aviation Aircraft RAC 11.2
- Flight Plan/Itinerary
 - Aerodrome, Departure and Time RAC 3.16.5
 - Aerodrome, Destination, Total Estimated
Elapsed Time, SAR Time (Canadian only)
and Alternate Aerodrome(s).....RAC 3.16.7
 - Aircraft IdentificationRAC 3.16.1
 - Alternate Aerodrome for IFR Flight.....RAC 3.14
 - CanadianRAC 3.15.2
 - Changes to the Information RAC 3.7
 - Closing RAC 3.12
 - Closing of a Flight Plan or Flight Itinerary
Prior to Landing RAC 3.12.2
 - Composite, VFR and IFR RAC 3.8
 - Contents.....RAC 3.16
 - Cross Country Instrument Training Flights..RAC 3.11
 - Cruising Speed, Altitude/Level
and Route.....RAC 3.16.6
 - Defence VFR (DVFR) and Defence
Flight Itineraries..... RAC 3.9
 - Equipment (Canadian and ICAO)RAC 3.16.4
 - Filing (CAR 602.75)..... RAC 3.6.2
 - Flight Rules and Type of FlightRAC 3.16.2
 - Flights Along or Outside Designated
ATS RoutesRAC 3.16.6
 - Forms, Completion of RAC 3.15
 - Fuel Requirements RAC 3.13
 - Fuel, Sufficient Amount, IFR/VFR Flights
..... RAC 3.13.1, 3.13.2
 - ICAORAC 3.15.3, Fig. 3.2
 - IFR..... RAC 3.15
 - IFR Flight Plan.....RAC 3.7.2
 - Intermediate Stops RAC 3.10
 - Number and Type of Aircraft
and Wake Turbulence CategoryRAC 3.16.3
 - Other InformationRAC 3.16.8
 - Opening a VFR Flight Plan
or Flight Itinerary..... RAC 3.6.4
 - Requirements – Flights Between Canada
and a Foreign State..... RAC 3.6.3
 - Sample – Composite IFR/VFR/ IFR
Flight Itinerary RAC Fig. 3.1
 - IFR (ICAO)RAC Fig. 3.2
 - VFR..... RAC Fig. 3.3
- Type of Flight and Flight RulesRAC 3.16.2
- VFR Flight Plan or Flight ItineraryRAC 3.7.1
- Flight Operations..... AIR 2.0
 - At night..... AIR 2.16
- Flight Planning RAC 3.0
- Flow Control Procedures..... RAC 12.10
- Flying Low, Hazards of..... AIR 2.4
- Forecast
 - Aerodrome Forecasts from AWOS Sites ... MET 3.9.4
 - Area (GFA).....MET 3.3
 - Aviation, Abbreviations MET 3.6
 - Charts (PROG) MET 3.12
 - Significant Weather Prognostic Charts
 - CMC MET 3.14
 - RAFC MET 3.13
 - TAF (Aerodrome).....MET 3.9
 - Upper Level Charts – PROG..... MET 3.12
 - Upper Level Wind and Temperature (FD)
..... MET 1.1.3, 3.11
 - Winds and Temperatures Aloft Network,
Canadian MET 3.10
- Forest Fires
 - Temporary Flight Restrictions RAC 2.9.2
- Formation Flight – IFR and CVFR RAC 12.13.3
 - Procedures..... RAC 12.13
- French, Use of in Communications..... COM 5.2
- Frequency
 - Mandatory (MF), Use of..... RAC 4.5.4, 4.5.6
 - Monitoring 126.7 MHz RAC 5.1
 - Release from Tower..... RAC 4.2.9
- FSS (Flight Service Stations) RAC 3.4.1
 - Services Provided.....RAC 1.1.3
- Fuels
 - Anti-icing Additives AIR 1.3.3
 - Aviation AIR 1.3
 - Fuel Conservation High Level AirspaceRAC 12.11
 - Dumping..... RAC 6.3.4
 - Fires and Explosions AIR 1.3.4
 - GradesAIR 1.3.1
 - Handling..... AIR 1.3.2
 - Minimum Fuel Advisory RAC 1.8.2
 - Requirements RAC 3.13
 - Sufficient Amount, IFR/VFR Flights
..... RAC 3.13.1, 3.13.2
- Fuel and Oil Weights RAC 3.5.2
- Fur and Poultry Farms, avoidance..... RAC 1.14.1

G

- Gander Radio..... COM 6.6.1
- Geographic Reference/Co-ordinates GEN 1.5.2
- Glassy Water and Landing Seaplanes AIR 2.11.4
- Global Navigation Satellite System (GNSS)COM 3.15
 - Approach Procedures.....COM 3.15.5.2
 - Approach Procedures with Barometric Vertical
Navigation (BARO VNAV) COM 3.15.5.2.4
 - Approach Procedures with
Vertical Guidance (APV).....COM 3.16.5
 - Approaches at Alternate Aerodromes.... COM 3.15.12
 - Avionics DatabasesCOM 3.15.8

- Augmentation Systems (ABAS, SBAS, GBAS) COM 3.15.4
- Communication, Navigation, Surveillance Implementation Team (CNS IT) COM 3.15.17
- Current Approvals..... COM 3.15.5
- Domestic En route and Terminal Operations COM 3.15.5.1
- GNSS Vulnerability
 - Interference, Anomaly Reporting COM 3.15.15
- Navigation Performance Requirements. COM 3.15.14
- Next Generation GNSS COM 3.15.13
- NOTAM COM 3.15.6.1
- Proper use of COM 3.15.16
- User Comments..... COM 3.15.18
- Glossary of Aeronautical Terms..... GEN 5.1
- Graphic Area Forecast (GFA)..... MET 3.3
- Gross Navigation Errors, Monitoring of..... RAC 11.22.7
- Ground-to-Air Signals..... SAR 4.8.1
- Guidance Signs, Operational..... AGA 5.8

H

- Hang Glider Operations AIR 4.9
- Health and Safety Program, Transport Canada
 - Aviation Occupational (A-OH&S)..... GEN 2.1
- Heaters, Portable Combustion – Danger of..... AIR 3.3
- Height Monitoring RAC 11.23.6, 12.16.9
 - Height Monitoring Unit (HMU) RAC 11.23.7
- Helicopter Operations..... RAC 4.5.3, 4.6
 - At Controlled Airports..... RAC 4.6
 - Takeoff, Landing and Safety Areas AGA 3.11
 - Vortices AIR 2.9
- Heliports AGA 5.5
 - Arrival and Departure Hover Area..AGA 3.11.1, 7.16.1
 - Lighting AGA 7.16
 - Markers and Markings..... AGA 5.5
- High Altimeter Settings RAC 12.12, AIR 1.5.9
- High Altitude Flight in Aircraft with Unpressurized Cabins AIR 3.4
- High Intensity Runway Operations (HIRO) RAC 4.4.10
- Hijack (Unlawful Interference) RAC 1.9.8
- Holding
 - Clearance RAC 10.2
 - DME Procedures RAC 10.8
 - Pattern, Entry Procedures RAC 10.5
 - Pattern, Non-Standard RAC 10.4
 - Pattern, Speed Limitations, DME Procedures, Shuttle Procedure RAC 10.7, 10.8, 10.9
 - Pattern, Standard..... RAC 10.3
 - Pattern, Timing RAC 10.6
 - Patterns Depicted on En Route and Terminal Charts..... RAC 10.10
 - Positions, Taxi..... RAC 4.2.6
 - Procedures
 - IFR..... RAC 10.0
 - VFR..... RAC 4.4.2
 - Speed Limitations RAC 10.7
- Hover
 - Arrival and Departure Hover Area Marking..... AGA 5.5.4

- Taxi..... RAC 4.6
- Taxiway Route Markers, Helicopter AGA 5.2
- Hydroplaning..... AIR 1.6.5
- Hyperventilation..... AIR 3.2.2
- Hypothermia and Hyperthermia AIR 3.17
- Hypoxia AIR 3.2.1

ICAO

- Applicable ICAO and WMO Documents MET 1.1.7
- ICAO Flight Plan Form, Sample RAC Fig. 3.2
- ICAO Type A Charts MAP 3.6
- Ice Control and Snow Removal..... AGA 1.1.5
- Ice

- Aircraft Contamination on the Ground, and in Flight AIR 2.12.2, 2.12.3
- Accumulation MET 2.4
- Types of Ice AIR 2.12.3.1
- Aerodynamic Effects of Airborne Icing.. AIR 2.12.3.2
- Roll Upset..... AIR 2.12.3.3

IFR

- Advance Notice of Intent RAC 9.5
- Aeronautical Information..... MAP 3.0
- Air Traffic Control Clearance..... RAC 6.1
- Aircraft Categories..... RAC 9.21
- Altitude Reports RAC 8.4
- Application of Takeoff Minima RAC 9.19.1
- Approach Ban..... RAC 9.19.2
- Approach Clearance..... RAC 9.3
- Approach Position Reports – Controlled Airports..... RAC 9.9
- Arrival Procedures..... RAC 9.0
- Uncontrolled Aerodromes/Airspace.... RAC 9.12, 9.13
- ATC Assignment of Altitudes..... RAC 8.7
- Circling..... RAC 9.23
- Procedures..... RAC 9.24
- Clearance with VFR Restrictions RAC 6.2.1
- Clearances RAC 7.4
- Clearances – Leaving or Entering Controlled Airspace RAC 8.9
- Climb or Descent RAC 8.5
- Contact and Visual Approaches..... RAC 9.6
- Corrections for Temperature..... RAC 9.17.1, Fig. 9.1
- Cross Country Training Flight..... RAC 3.11
- Departure, Approach and Alternate Minima..... RAC 9.18
- Departure Procedures RAC 7.0
- Departure from Uncontrolled Aerodromes... RAC 7.9
- Descent Out of Controlled Airspace..... RAC 9.4
- DME Holding Procedures..... RAC 10.8
- Emergencies and Equipment Failures..... RAC 6.3
- En Route Procedures..... RAC 8.0
- En Route – Uncontrolled Aerodromes (Class-“G” Airspace)..... RAC 8.11
- Flight – Two-Way Communications Failure RAC 6.3.2
- Flight Plan RAC 3.7.2
- Flight Plan – Completion of..... RAC 3.15
- Flight, “1 000-Ft-on-Top” RAC 8.8
- Flights in VMC RAC 6.2

- Formation Flights RAC 12.13
- General RAC 6.0
- Holding Clearance..... RAC 10.2
- Holding Entry Procedures RAC 10.5
- Holding Pattern, Speed Limitations RAC 10.7
- Holding Pattern, Timing RAC 10.6
- Holding Procedures..... RAC 10.0
- ILS, Category II Minima RAC 9.18.1
- Initial Contact at Uncontrolled
Aerodromes RAC 9.11
- Initial Contact with Tower RAC 7.3, 9.9
- Instrument Procedures, Development of..... RAC 6.5
- Landing Minima RAC 9.19.3
- Mach Number..... RAC 8.3.1, 11.13, 12.1
- Minimum Altitudes..... RAC 8.6
- Missed Approach Procedures RAC 9.26
- Missed Approach Procedures – Visual..... RAC 9.25
- Noise Abatement Procedures – Departure ... RAC 7.6
- Non-Standard Holding Pattern RAC 10.4
- Obstacle and Terrain Clearance..... RAC 7.7
- Outbound Report..... RAC 9.14
- PAR (Precision Radar Approaches)
..... COM 3.14, RAC 9.8.4
- Position Reports RAC 8.1
- Preferred Routes RAC 3.16.6
- Preferred IFR Routes (Including RNAV) . RAC 12.6.3
- Procedure Altitudes RAC 9.17
- Procedures – Uncontrolled Aerodromes/Airspace
..... RAC 4.5.2, 9.14
- Published Holding Patterns..... RAC 10.10
- Radar Arrivals..... RAC 9.7
- Release from Tower Frequency..... RAC 7.8
- Remote Altimeter Setting RAC 9.17.2
- Reporting of Equipment Malfunction RAC 6.3.3
- Reporting Procedures
- Uncontrolled Aerodrome RAC 9.12
- Required Visual Reference RAC 9.19.3
- Runway Visual Range (RVR) RAC 9.20
- Separation..... RAC 6.4
- Shuttle Procedure RAC 10.9
- Simultaneous Approaches RAC 9.27
- Speed Adjustment – Radar Controlled Aircraft
..... RAC 9.8.3
- Standard Holding Pattern..... RAC 10.3
- Standard Instrument Departure (SID) RAC 7.5
- Standard Terminal Arrival (STAR) RAC 9.2
- Straight-in Approach..... RAC 9.15
- Straight-in Landing Minima RAC 9.22
- True Airspeed (TAS) RAC 8.3.2
- Uncontrolled Airspace RAC 9.13
- Visual Approach..... RAC 9.6.2
- ILS (Instrument Landing Systems)..... COM 3.12
 - Automatic Landing (Autoland) Operations
..... COM 3.12.1
 - Categories..... COM 3.12.6
 - Glide Path COM 3.12.3
 - Localizer COM 3.12.1, 3.12.2
 - Minima, Category II RAC 9.18.1
- Importation of
 - Aircraft into Canada LRA 4.6
 - Plants and Animals FAL 2.5
- Index
 - Aerodrome Obstacle Charts
 - ICAO Type A..... MAP 3.6.2
 - Legislation – *Canadian Aviation Regulations* GEN 5.3
- Inertial Navigation System (INS)..... COM 3.14
- Information
 - Survival Advisory AIR ANNEX
 - Weather MET 3.2
- Initial Contact..... RAC 4.4.1, 9.9
- INMARSAT COM 5.11
- Interception – Procedures..... SAR 4.7 SCHEDULE I
 - Visual Signals for Use in the Event of
..... SAR 4.7 SCHEDULE II
- Intermediate Approach..... RAC 9.16
- Intermediate Stops..... RAC 3.10
- International Civil Aviation Organization (ICAO)
 - Definitions..... AGA 1.2.1
 - Differences with ICAO Standards, Recommended
Practices and Procedures GEN 1.3, AGA 1.1.3
 - Documents AGA 1.1.2
- Internet address (Transport Canada Home Page)... LRA 5.7
- Instrument
 - Flight Rules – General RAC 6.0
 - Rating Minima RAC Fig. 9.2
- Insurance
 - Liability LRA 4.8
- Interference with Aircraft Navigational Equipment
..... COM 3.1.2
- International Air-to-Ground Service COM 6.2
- International Flights
 - Aerodrome Use FAL 2.2.1
 - Charts MAP 8.0
 - Transborder Flights FAL 2.3.2
 - Commercial Flights..... FAL 2.2.2
 - Documents Required by Passengers
for CIS FAL 2.2.4, 2.2.6, 2.3.3
 - Importation of Plants and Animals..... FAL 2.5
 - Passports FAL 2.2.4
 - Private Flights FAL 2.3
 - Public Health Measures FAL 2.4
 - Services Available for Aircraft Engaged in .. COM 6.2
 - Visas FAL 2.2.5
 - HF A/G Frequencies, Use of General Purpose
VHF, in Lieu of COM 6.7
- Intersecting Runways, Operations on RAC 4.4.9

J

- Jet and Propeller Blast Danger AIR 1.7

L

- Landing, Automatic, Operations..... COM 3.13.1, AIR 2.15
- Landing Distance Available (LDA)..... AGA 3.8
- Landing Lights, Collision Avoidance..... AIR 4.5
- Landing Minima..... RAC 9.19.3
- Legislative Index
 - *Canadian Aviation Regulations*..... GEN 5.3

Licences

- Airline Transport.....LRA 1.7.4
- Commercial PilotLRA 1.7.3
- Differences with ICAO Standards LRA 1.8
- Flight Engineer.....LRA 1.7.6
- Medical Examination RequirementsLRA 2.2
- Multi-crew.....LRA 1.7.5
- PilotLRA 1.7.1
- Private Pilot.....LRA 1.7.2
- Recency RequirementsLRA 1.7.2
- Reinstatement of Suspended LicenceLRA 1.11

Licensing

- Flight Crew Licensing AdministrationLRA 1.14
- Flight Crew Conversion Agreement between Canada and the United StatesLRA 1.13
- Flight Crew Licensing..... LRA 1.0
- Licensing and Registration of Aircraft LRA 4.5

Life-Saving Equipment for Aircraft

- Operating Over Water.....AIR 2.11.3

Light Aircraft

- Crosswind Landing Limitations AIR 2.2

Lighting

- Aerodrome..... AGA 7.0
- Approach AGA 7.5
- Approach and Departure Hover Area..... AGA 7.16.2
- Displaced Runway Threshold AGA 7.9
- Emergency..... AGA 7.17
- Heliport AGA 7.16
- High Intensity Approach (HIAL) AGA 7.5.2
- Low Intensity Approach (LIAL)..... AGA 7.5.1
- Medium Intensity Approach, System with Runway Alignment Indicator Lights (MALSR) AGA 7.5.2
- Medium Intensity Approach, System with Sequenced Flashing Lights (MALSF) AGA 7.5.1
- Night..... AGA 7.3
- Obstructions AGA 6.0
- Omnidirectional Approach (ODALS)..... AGA 7.5.1
- Rapid-Exit Taxiway..... AGA 7.12
- Runway..... AGA 7.8
- Runway Centre Line AGA 7.10
- Runway Touchdown Zone.....AGA 7.11
- Taxiway AGA 7.13
- Unserviceable Area Markings AGA 7.4

Lights

- Approach and Take-Off Direction Lights . AGA 7.16.2
- Runway Edge Lights AGA 7.8.1
- Runway Threshold End Lights AGA 7.8.2
- Use of Landing Lights – Collision Avoidance. AIR 4.5
- Use of Strobe..... AIR 4.6

Lights, Runway Identification (RILS) AGA 7.7

Limited Weather Information Systems (LWIS)

- MET 1.1.5, 1.2.5

Localizer..... COM 3.12, 3.13.2

Logging Operations..... AIR 2.4.2

Low

- Level Controlled Airspace RAC 2.7
- Level Wind Shear..... AIR 2.8

- Flying AIR 2.4
- Flying near power lines..... AIR 2.4.1

M

Mach Number

- Clearances and Reports..... RAC 8.3
- Adherence to RAC 11.13, 12.1
- True Airspeed (TAS) or RAC 11.6.2

Maintenance Requirements

- For Canadian Registered Aircraft..... LRA 5.6
- Aircraft used in Dual Role Operations..... LRA 5.6.2

Maintenance Certificate..... LRA 5.4

Major Errors in Altimeter.....RAC Fig. 9.1, AIR 1.5.4

Mandatory Frequency (MF), Use of RAC 4.5.4, 4.5.6

Mandatory Instruction Signs..... AGA 5.8.3

Manned Free Balloon Operations AIR 4.7

Manoeuvring Area, Visual..... RAC 9.25

MANOT (Missing Aircraft Notice) SAR 2.3

Markers

- Aerodrome Boundary AGA 5.1
- Retroflective..... AGA 7.19
- Seaplane Dock..... AGA 5.3
- Shore..... AGA 6.7
- Takeoff or Landing Area Boundary AGA 5.1

Markings

- Aerodrome..... AGA 5.1
- Appurtenances AGA 6.6
- Apron Touchdown Pad..... AGA 5.5.5
- Arrival and Departure Hover Area..... AGA 5.5.4
- Cable Spans AGA 6.2, 6.7
- Closed..... AGA 5.6
- Day Marking AGA 6.4
- Displaced Threshold AGA 5.4.1
- Helicopter Safety Area Markers AGA 5.5.2
- Heliports..... AGA 5.5
- Heliport Identification..... AGA 5.5.3
- Heliport Takeoff and Landing Area Marking AGA 5.5.1
- Holding..... AGA 5.4.3
- Hover Area AGA 5.5.4
- Obstruction..... AGA 6.0
- Power Line Crossings..... AGA 6.7
- Preferred Approach and Departure Path ... AGA 5.5.6
- Requirements for an Aeronautical Evaluation AGA 6.3
- Runway..... AGA 5.4
- Standards..... AGA 6.2
- Taxiway Exit and Holding AGA 5.4.3
- Displaced Threshold AGA 5.4.1
- Unserviceable Area..... AGA 5.7

Marshalling Signals..... AIR 1.8

Measurement, Units of GEN 1.5

MEDEVAC – Call Signs COM 5.8.1

Medical

- Aeromedical Factors AIR 3.2
- Assessment Process LRA 2.1
- Aviation Medical Review Board..... LRA 2.4
- Examination Requirements..... LRA 2.2
- Fitness for Permits and Licences LRA 1.9
- Periodic Medical Exam Categories 1, 2 3

Medically Fit	LRA 2.3	– Ice Accumulation	MET 2.4
– Unfit Assessment	LRA 2.5	– Locations – Aerodrome Forecast.....	MET 3.8
Medical Information.....	AIR 3.0	– METAR (Aviation Routine Weather Report).....	MET 1.2.2, 3.2.2, 3.15
– Alcohol	AIR 3.11	– Observations and Reports.....	MET 1.2
– Anesthetics	AIR 3.13	– PATWAS	MET 1.3.5
– Blood Donation	AIR 3.14	– Pilot Report (PIREP)	
– Carbon Monoxide.....	AIR 3.2.3	–	MET 1.1.3, 1.1.6, 2.0, 3.17, RAC1.1.3
– Decompression Sickness.....	AIR 3.5	– Reference Points Map	MET 3.5
– Disorientation.....	AIR 3.9	– Report (AIREP).....	MET 1.1.6, RAC 11.15
– Drugs.....	AIR 3.12	– Reports, Forecasts and Charts	MET 3.2.1, 3.2.2
– Dry Ice – Safety Precautions	AIR 3.16	– Responsibility.....	MET 1.1.1
– Fatigue.....	AIR 3.10	– Services Available.....	MET 1.1.2
– General Health	AIR 3.1	– SIGMET	MET 1.1.3, 3.18
– High Altitude Flight in Aircraft with Unpressurized Cabin.....	AIR 3.4	– SPECI (Special Weather Reports)	
– Hyperventilation	AIR 3.2.2	–	MET 1.2.2, 3.15.4, 3.15.5
– Hypothermia and Hyperthermia.....	AIR 3.17	– Special VFR Weather Minima.....	RAC Fig. 2.8
– Hypoxia.....	AIR 3.2.1	– Stations and Office – Aeronautical.....	MET 1.2.1, 3.1
– Mandatory Medical Reporting	AIR 3.1.1	– Surface Weather Maps.....	MET 3.19
– Middle Ear and Sinus Discomfort or Pain.....	AIR 3.8	– Symbols	
– Portable Combustion Heaters, Potential Hazard of.....	AIR 3.3	– Significant Weather.....	MET 3.14
– Pregnancy.....	AIR 3.15	– Surface Weather Maps.....	MET 3.19
– Scuba Diving.....	AIR 3.6	– TAF (Aerodrome Forecast).....	MET 1.1.3, 3.9
– Vision	AIR 3.7	– Turbulence Reporting Criteria Table	MET 3.7
Meteorite Reports.....	RAC 1.12.3	– Upper Level Charts, analysed (ANAL)	MET 3.20
Meteorological / Meteorology		– Upper Level Wind and Temperature Forecasts.....	MET 1.3.7, 3.11
– Abbreviations, Significant Weather.....	MET 3.14	– VOLMET	COM 6.2.3, MET 1.4
– AIRMET	MET 1.1.3, 1.3.4, 1.3.6, 3.4	– Weather Charts.....	MET 3.2.3
– Authority, Areas of Responsibility	MET 1.1.1	– Weather Observing Systems ...	MET 3.2.2, 3.2.3, 1.1.5
– Automated Reports		– Weather Radar.....	COM 3.14, MET 1.3.10
– Other.....	MET 3.15.6	– Wind Shear.....	MET 2.3
– Reports from Other Non-aviation Autostations	MET 3.15.6.2	Middle Ear and Sinus Discomfort or Pain	AIR 3.8
– Voice Generator Module (VGM)	MET 3.15.6.2	Migratory Birds.....	RAC 1.14.4, 1.16.2
– Aviation Forecasts, Abbreviations	MET 3.6	– Charts	RAC 1.15.2
– METAR (Aviation Routine Weather Report)	MET 3.2.2, 3.15	– Protection, Hazard	RAC 1.14.4
– Aviation Weather Briefing Service (AWBS)	MET 1.1.3	Military	
– Aviation Weather Information Service (AWWS).....	MET 1.1.3	– Arrester Cables	AGA 9.1
– Aviation Weather Reports.....	MET 3.2.2, 3.15	– Flight Advisory Unit (MFAU).....	RAC 1.1.6
– Aviation Weather Services.....	MET 1.1.3	– Radar Assistance (Canadian Forces)	RAC 1.5.7
– AWOS (Automated Weather Observation System).....	MET 3.15.5	Minima	
– Canadian Forecast Winds and Temperatures Aloft Network	MET 3.10	– Application of.....	RAC 9.19
– Canadian Meteorological Centre (CMC)....	MET 3.14	– Circling.....	RAC 9.23
– Canadian Weather Information.....	MET 1.3.5, 3.2	– Departure, Approach and Alternate	RAC 9.18
– Centres, Location of Canadian Weather.....	MET 3.1	– Straight-in Landing	RAC 9.22
– Charts and Forecasts	MET 1.3	Minimum	
– Clear Air Turbulence (CAT), Avoidance of.....	MET 2.2, AIR 2.10	– Altitudes – Overflying Aerodromes.....	RAC 5.5
– Coastal Weather	MET 1.3.5	– Altitudes – VFR.....	RAC 5.4
– Differences with ICAO Annex-3	MET 1.1.8	– En-Route Altitudes (MEA).....	RAC 8.7.1
– EC/DND Weather Radar Network.....	MET 3.16	– Fuel Advisory.....	RAC 1.8.2
– GFA (Area Forecast)	MET 1.1.3, 1.3.6, 3.3	– Holding Altitude (MHA)	RAC 10.7
– Forecasts and Charts	MET 1.3	– IFR Altitudes.....	RAC 8.6, 8.7.1
		– Geographic Area Safe Altitude (GASA)....	RAC 8.7.1
		– Obstruction Clearance Altitude (MOCA)	
		–	RAC 8.6, 8.7.1
		– Sector Altitude (MSA).....	RAC 9.2.4
		Minimum Navigation Performance Specifications (MNPS).....	RAC 11.10, 11.22.6
		– Certification	RAC 11.6.5, 11.22.8

- Navigation Errors, Monitoring of Gross.RAC 11.22.7
- North Atlantic (NAT) MNPS Operations COM 3.15.11
- Missed Approach
 - From a Circling Procedure..... RAC 9.25
 - Procedures..... RAC 9.26
- Monitoring Emergency Frequency 121.5 MHz...COM 5.12
- Morning and Evening Civil Twilight Charts GEN 1.6.2
- Morse Code and the Phonetic Alphabet..... COM 5.4
- Mountainous
 - Areas, Flight Operations in..... AIR 2.13
 - Regions.....RAC 2.12, Fig. 2.11

N

- North American Approvals Registry and Monitoring
 - Organization (NAARMO)..... RAC 12.16.10
- NAR (North American Routes) RAC 11.3
- National Harbours Board Act..... AIR 2.11.1
- Nationality and Registration MarksGEN 1.7, LRA 1.3
- NAV CANADA
 - Air Navigation Service Charges FAL 3.2
 - Regions – Addresses, Facsimile and Telephone Numbers..... GEN 1.1.2
- NAVAID
 - DME (Distance Measuring Equipment)..... COM 3.7
 - LOC (Localizer)..... COM 3.11, 3.13.2
 - NDB (Non-Directional Beacon)COM 3.6, 3.12.4
 - Radio Navigation Aids..... COM 3.0
 - TACAN (Tactical Air Navigation)..... COM 3.8
 - VDF (VHF Direction Finding System)COM 3.10, RAC 1.6, SAR 4.3
 - VOR (VHF Omnidirectional Range)..... COM 3.5
 - VORTAC (VOR and TACAN)..... COM 3.9
 - Navigation Aids
 - Accuracy, Availability and Integrity of COM 3.3
 - Assistance ServiceRAC 1.1.3
 - Monitoring ServiceRAC 1.1.3
 - Pilot Reporting of Abnormal Operation of.. COM 3.4
- Navigation System
 - INS (Inertial Navigation System)COM 3.15
 - GNSS (Global Navigation Satellite System)COM 3.15,
 - GPS (Global Positioning System)COM 3.15.3
 - NDB (Non-Directional Beacon)COM 3.6, 3.12.4
 - VOR/DME (RHO-THETA)..... COM 3.14.1
- NCA (Northern Control Area) Track StructuresRAC 12.7.1
- Night Lighting AGA 7.3
- Night, Flight Operations at..... AIR 2.16
- Noise
 - AbatementRAC 4.1.2, 7.6
 - Preferential RunwaysRAC 4.1.3, 7.6.2
- Non-Directional Beacon (NDB).....COM 3.6, 3.12.4
- Non-scheduled International Air ServiceFAL 2.2.2
- NORDO/ONLY..... RAC 4.2.10, 4.2.12, 4.4.5, 4.4.6, 4.5.7, 4.5.8
- North American Route Program (NRP) RAC 12.6.2
- North American Routes (NAR) RAC 11.3, 12.7.3
- North Atlantic
 - Clearances RAC 11.8

- Communications Failure..... RAC 11.20
- Documents and Guidance Material RAC 11.1.2
- Domestic Clearances RAC 11.8.2
- Families of HF..... COM 6.2.1
- Flight Planning Procedures..... RAC 11.6
- Flight Rules RAC 11.5
- In-flight ContingenciesRAC 11.19
- Minimum Navigation Performance Specifications Airspace (NAT MNPSA)..... RAC 11.10, 11.22
- Oceanic Clearance Delivery RAC 11.8.3
- Operations (NAT) RAC 11.0, COM 3.16.4.4
- Organized Track System..... RAC 11.4
- Regulation RAC 11.1.1
- Step-Climb Procedure.....RAC 11.17
- Transponders, Operation ofRAC 11.14
- VHF coverage COM 6.6.4
- Northern and Southern Domestic Airspace..... RAC 2.2.1
- Northern Canada, Single-engine Aircraft OperationsAIR 2.14.1
- Northern Control Area (NCA), position reporting within RAC 12.6.5
- NOTAM..... MAP 5.0
 - Collection, Evaluation and Dissemination.. GEN 1.1.5
 - Criteria for Issuance..... MAP 5.4
 - Distribution – Canadian, International. MAP 5.2, 5.3
 - Format MAP 5.6
 - Information for Flight Planning..... RAC 3.3
 - Location Indicators – Files..... MAP 5.6.8
 - GPS Satellite OutagesCOM 3.15.6
 - ServiceRAC 1.1.3
 - Summaries MAP 5.5
- Notice – PNR (Prior Notice Required)AGA 2.2
- Numbers, Use of..... COM 5.7

O

- Obstacle
 - And Terrain Clearance..... RAC 7.7
 - Clearance During Radar Vectors..... RAC 1.5.5
 - Limitation Surfaces.....AGA 4.2
 - Restrictions AGA 4.0
 - Heliports.....AGA 4.2.2
- Obstruction
 - Appurtenances AGA 6.6
 - Day LightingAGA 6.5
 - Day Marking AGA 6.4
 - Markings AGA 6.0
 - Markings, StandardsAGA 6.2
 - Requirement for an Aeronautical Evaluation. AGA 6.3
 - Suspended Cable Span Markings AGA 6.7
- Occupational Health and Safety Program, Aviation (A-OH&S) GEN 2.1
 - Civil Aviation Safety Inspectors..... GEN 2.1.3
- Occurrence – Reporting an Aviation GEN 3.3
- Occurrence Sites, Aircraft, Components and Documentation, Protection of..... GEN 3.4
- Oceanic ClearancesRAC 11.8.1
- Oceanic Services FAL 3.2.2
 - NAT - En-route Facilities and Services Charge FAL 3.2.2.1

- International Communication Services Charge FAL 3.2.2.2
- Customer Service and Accounts Inquiries . FAL 3.2.3
- Oil and Fuel Weights RAC 3.5.2
- Operational Guidance Signs..... AGA 5.8.2
- Operations
 - On Intersecting Runways..... RAC 4.4.9
 - Sequential..... RAC 4.4.9
 - Simultaneous..... RAC 4.4.9
- Organized Track System (NAT) RAC 11.4
- Over-the-Top, VFR..... RAC 2.7.4
- Overflying Aerodromes, Minimum Altitudes..... RAC 5.5

P

- PAPI (Precision Approach Path Indicator) .. AGA 7.6.1, 7.6.4
- Parachute Jumping..... AIR 4.8
- Paraglider operations..... AIR 4.9
- Parks, refuges and reserves (National, Provincial and Municipal) RAC 1.14.5
- Passenger(s) – Actual Weights RAC 3.5.1
 - Weight standards..... RAC 3.5
- Passports and Visas, Requirements for..... FAL 2.2.5
- PATWAS (Pilots Automatic Telephone Weather Answering Service)..... MET 1.3.5
- Pavement Load Rating Charts..... AGA 3.10.1
- Permission – PPR (Prior Permission Required).... AGA 2.2
- Permits
 - Medical Examination Requirements LRA 2.2.
 - Reinstatement of a suspended..... LRA 1.11
 - Student Pilot LRA.6.1
 - Summary of Requirements LRA 1.6
- Phonetics, Use of COM 5.4
- Phone use During a Radio Communications Failure..... COM 5.15
- Photographic Survey Flights RAC 12.14
- Pilot
 - Permits LRA 1.4.1, 1.6.2
 - Reporting of Abnormal Operation of Navigation Aids COM 3.4
 - Reports – CIRVIS, Meteorite, Fire Detection and Pollution..... RAC 1.12
 - Vital Action Checklists AIR 1.2
 - Waivers – Wake Turbulence..... RAC 4.1.1
- Pilots Automatic Telephone Weather Answering Service (PATWAS) MET 1.3.5
- PIREP (Pilot Report)..... MET 1.1.6, 2.0, 3.17, RAC 1.1.3
- Plants and Animals, Regulations Concerning the Importation of FAL 2.5
- Pollution Reports RAC 1.12.5
- Portable Passenger Operated Electronic Devices
 - on Board Aircraft, Use of COM ANNEX B 1.0
 - Regulatory Requirement..... COM ANNEX B 2.0
 - Operating Procedures COM ANNEX B 3.0
 - Informing Passengers..... COM ANNEX B 3.1
- Portable Two-way Radiocommunication Devices COM ANNEX B 1.1
- Position Reports..... RAC 11.9
 - IFR..... RAC 8.1
 - VFR..... RAC 5.1

- Automatic Dependent Surveillance Waypoint Position Reporting (FANS 1/A ADS WPR) RAC 8.2
- Positive and Negative G AIR 3.18
- Power-back / Push-back Requests..... RAC 4.2.4
- Power Line Crossing Markings AGA 6.7
- Practice Spins AIR 4.3
- Precision Approach Path Indicator (PAPI) AGA 7.6.1, 7.6.4
- Preferential Runways
 - Assignments RAC 4.1.3
 - Noise..... RAC 7.6.2
- Preferred Routes Messages (PRM) RAC 11.7
- Preflight
 - Reference Information MAP 1.2
 - Service, Single Source RAC 3.4
- Pregnancy AIR 3.15
- Pre-threshold Area AGA 3.5
- Pressure
 - Altimeter AIR 1.5
 - Drop..... AIR 1.5.8
 - Region, Standard..... AIR 1.5.5
- Private
 - Advisory Stations – Controlled Airports RAC 1.2.3
 - Aircraft Program (CANPASS)..... FAL 2.3.3
- Procedure(s)
 - Flow Control RAC 12.10
 - Altitudes RAC 9.17
 - Downed Aircraft SAR 4.8
 - Flight Procedures when the Barometric Pressure Exceeds 31.00 Inches of Mercury RAC 12.12.2
 - RVSM In-flight RAC 12.16.4
 - Terminal Instrument MAP 3.3.2
- Propeller and Jet Blast Danger AIR 1.7
- Protection of Occurrence Sites, Aircraft, Components and Documentation..... GEN 3.4
- Public Health Measures Applied to Aircraft..... FAL 2.4
- Publications and Charts, Procurement of Aeronautical..... MAP 7.0
- Push-back / Power-back Requests..... RAC 4.2.4

R

- RADAR COM 3.13
 - Alerting Manoeuvres SAR 4.5
 - Arrivals RAC 9.8
 - ASDE (Airport Surface Detection Equipment) COM 3.13
 - Canadian Forces Radar Assistance..... RAC 1.5.7
 - EC/DND Weather Radar Network..... MET 3.16
 - Navigation Assistance to VFR Flights RAC 1.5.4
 - Network, EC/DND Weather, MET 3.16
 - Obstacle Clearance During Radar Vectors . RAC 1.5.5
 - PAR (Precision Approach)..... COM 3.13
 - Primary Surveillance Radar (PSR)..... COM 3.13
 - Required RAC 9.8.2
 - Secondary Surveillance Radar (SSR) COM 3.13
 - Service..... RAC 1.5
 - Procedures..... RAC 1.5.2
 - Surveillance – VFR..... RAC 5.7
 - Traffic Information (Clock System)..... RAC 1.5.3

- Use of Radar in the Provision of AAS by FSSs RAC 1.5.8
- Vectors, Misuse of Radar..... RAC 1.5.6
- Vectors, Obstacle Clearance During..... RAC 1.5.5
- Weather Radar.....COM 3.14
- Radio
 - Checks..... COM 5.9, RAC 4.2.3
 - Navigation Aids..... COM 3.0
 - Radio Telephony Network Operations – North Atlantic Area (NAT)/Anchorage Arctic FIR. COM 6.6
 - Telephony, Standard..... COM 5.9
- Radio Communications..... COM 5.0
 - Arctic.....RAC 1.1.5
 - Call Signs COM 5.8
 - *Canadian Aviation Regulations (CARs)* COM ANNEX A 1.0
 - Channel Spacing COM 5.3
 - Phonetic Alphabet/Morse Code..... COM 5.4
 - Phonetic Designation of Air Routes and Airways COM 5.5
 - Radiocommunication Regulations..... COM 5.1
 - Regulations – Operator’s Certificates and Station Licences COM 5.1
 - Time, Heading, Altimeter, Flight Level..... COM 5.7
- Rapid-Exit Taxiway Lighting AGA 7.12
- Rapid-Exit Taxiways AGA 3.9
- Readability Scale – Communications ChecksCOM 5.10
- Recency Requirements – Pilot Licence Privileges..LRA 3.9
- Recreational AviationAIR 4.7 to 4.10
- Reduced Lateral Separation, Arrangements for.. RAC 11.12
- Reduced Vertical Separation Minimum (RVSM) RAC 11.23, 12.17
 - Aircraft Approvals Process..... RAC 11.23.4, 2.17.2
 - Aircraft Certification.....RAC 12.4.2, 12.17
 - Air Traffic Control (ATC) Procedures.....RAC 12.17.3
 - Aircraft Without RVSM Capability RAC 12.17.6
 - Airworthiness and Operational Approval and Monitoring.....RAC 12.17.8
 - Altitude Transitions – 1000/2000 ft RAC 11.23.2, 12.16
 - Delivery flights for Aircraft that are on Delivery.....RAC 12.16.7
 - Flight Level Allocation Scheme RAC 11.21.3
 - Further Information RAC 11.23.11
 - GMU Monitoring.....RAC 11.21.8
 - Height Monitoring..... RAC 11.23.6, 12.16.9
 - Height Monitoring Unit (HMU)..... RAC 11.23.7
 - In-flight Procedures.....RAC 11.23.5
 - In-flight Contingencies RAC 12.16.12
 - Meteorological Effects..... RAC 11.23.4
 - Minimum Aircraft System Performance Specification.....RAC 11.11
 - Transition Area..... RAC Fig. 12.2, 12.3, 12.16
- REFLEXIONS – Aviation Safety..... GEN 3.5
- Refuges, Reserves and Parks (National, Provincial and Municipal)RAC 1.15.5
- Region(s)
 - Altimeter Setting..... RAC 2.10
 - Mountainous..... RAC 2.12, RAC Fig. 2.11
 - NAV CANADA..... GEN 1.1.2
 - Transport Canada.....GEN 1.1.1
- Regional System Safety Specialist..... GEN 2.2.2
- Registered Aerodrome..... AGA 2.1
- Registration Marks and Nationality GEN 1.7, LRA 4.3
- Regulations, Airport Zoning AGA 4.3
- Reinstatement of Suspended Permit, Licence or Rating..... LRA 1.11
- Remote Altimeter Setting..... RAC 9.17.2
- Remote Communications Outlets (RCO).....RAC 1.1.4
 - Dial-up RCOsRAC 1.1.4
 - Flight Information Service En Route (FISE)COM 5.8.3, RAC 1.1.3, 1.1.4, 4.5.1
 - Remote Aerodrome Advisory Service (RAAS)COM 5.8.3, RAC 1.1.3, 1.1.4, 4.5.1
- Reports
 - ATS – Possible Contravention of the Air RegulationsRAC 1.1.4
 - Automated Reports
 - Other..... MET 3.15.6
 - Limited Weather Information System (LWIS)MET 3.15.6.1
 - Voice Generator Module (VGM)MET 3.15.6.1
 - AWOS – METAR AUTO or SPECI AUTO MET 3.15.5
 - CIRVIS, Vital Intelligence Sightings..... RAC 1.12.2
 - CRFI.....AGA 1.1.4, AIR 1.6
 - Fire Detection – Northern Areas RAC 1.12.4
 - Meteorite RAC 1.12.3
 - Pilot (PIREP)..... MET 2.0, RAC 1.1.3
 - Pollution RAC 1.12.5
- Required Visual Reference.....RAC 9.19.3
- Reserves, Refuges and Parks (National, Provincial and Municipal)RAC 1.14.5
- Reservation, charter flights.....FAL 2.2.2
- Resolution Advisories (TCAS/ACAS) RAC 1.7
- Responsibilities
 - NAV CANADA..... GEN 1.1.2
 - Transport Canada.....GEN 1.1.1, AGA 2.3.3
- Restricted Airspace RAC 2.8.6
- Retroflective Markers..... AGA 7.19
- Right of Way – Collision Avoidance Regulations . RAC 1.10
- RILS (Runway Identification Lights) AGA 7.7
- RNAV (Area Navigation) OperationsCOM 3.14
 - Equipment Failure Procedures RAC 12.4.6
 - Fixed RNAV Routes..... RAC 12.6.4
 - Preferred IFR Routes RAC 12.6.3
- RNPC (Required Navigation Performance Capability) Airspace RAC 12.4
- RONLY (Receiver Only)/NORDO (No Radio), Procedures RAC 4.2.10, 4.2.12, 4.4.5, 4.4.6, 4.5.7, 4.5.8
- Route, Adherence to RAC 11.16
- Routes, Canadian Domestic RAC 12.6
 - Canadian Track Structures RAC 12.7
 - Fixed RNAV..... RAC 12.6.4
 - North American (NAR).....RAC 12.7.3
 - North American Route Program (NRP).. RAC 12.6.2
 - Preferred IFR Routes (including RNAV)

- RAC 3.16.6, 12.6.3
- RSC and CRFI Reporting AIR 1.6.4
- Runway(s)
 - Centre Line Lighting..... AGA 7.10
 - Characteristics..... AGA 3.0
 - CRFI..... AIR 1.6
 - Declared Distances AGA 3.8
 - Dimensions..... AGA 3.1
 - Friction Calibration Method AGA 1.1.4
 - Graded Area..... AGA 3.2
 - Heading RAC 7.5
 - Identification Lights (RILS)..... AGA 7.7
 - Intersecting, Operations on..... RAC 4.4.9
 - Lighting..... AGA 7.8
 - Markings AGA 5.4
 - Sequential Operations RAC 4.4.9
 - Simultaneous Operations..... RAC 4.4.9
 - Taxiway Bearing Strength AGA 3.10
 - Touchdown Zone Lighting..... AGA 7.11
 - Wet..... RAC 4.4.9, AIR 1.6.5
 - Winter Condition NOTAM..... AIR 1.6.4
- Runway Visual Range (RVR) RAC 9.20
 - Comparative Scale – Feet to Meters GEN 1.9.3
 - Operational use of RVR..... RAC 9.20.2

S

- Safety..... GEN 2.0
 - Alert Procedure and Phraseology RAC 12.15
 - Newsletters..... GEN 2.2.3
 - Occupational GEN 2.1
 - System Safety..... GEN 2.2
 - System Safety Specialists GEN 2.2.1, 2.2.2
- SAR (Search and Rescue) SAR 1.1
 - Agreements SAR 1.3
 - Aiding Persons in Distress..... SAR 2.4
 - Assistance, Request for..... SAR 2.2
 - Assistance to Aircraft With Emergencies..... SAR 4.0
 - Closing of a Flight Plan or Flight Itinerary
Prior to Landing..... RAC 3.12.2
 - Declaring an Emergency..... SAR 4.1
 - Distress Signal Panel..... SAR 2.4
 - Downed Aircraft Procedures..... SAR 4.8
 - Emergency Locator Transmitter SAR 3.0
 - Flight Planning..... SAR 2.0
 - Ground-to-Air Signals SAR 4.8.1
 - Interception Procedures SAR 4.7
 - MANOT (Missing Aircraft Notice)..... SAR 2.3
 - Procedures for Signaling Vessels..... SAR 2.4
 - Regions (SRR)..... SAR Fig. 1.1
 - Rescue Co-ordination Centres (RCCs)..... SAR 1.1
 - Responsible Authority..... SAR 1.0
 - Services Available..... SAR 1.2
 - Survival SAR 4.8.2
- Satellite Navigation (SatNav) COM 3.16.1
 - Current Approvals..... COM 3.16.4
 - Required Navigation Performance..... COM 3.16.7
- Scheduled International Air Service..... FAL 2.2.2
- Scuba Diving AIR 3.6
- Seaplane Dock Markers AGA 5.3

- Seaplanes
 - Landing on Glassy Water..... AIR 2.11.4
 - Landing on Unbroken Snow Conditions AIR 2.12.6
 - Use on Snow Surfaces..... AIR 2.12.5
- Search and Rescue (see SAR)..... SAR 1.1
- SECURITAS Program GEN 3.6
- Security, Emergency Communications and
..... COM 5.11, RAC 2.13
 - Distress Message from an Aircraft,
example of a COM 5.11
 - Urgency Message Addressed to All Stations,
example of a COM 5.11
- SELCAL (Selective Calling System) COM 6.4
- Sequential Operations RAC 4.4.9
- Service Difficulty Reporting Program LRA 2.6.4
- Services
 - AFS (Aeronautical Fixed) –
International Flights..... COM 6.0, 6.1, 6.1.2
 - Air Traffic RAC 1.1.1
 - Apron Advisory..... RAC 1.2.4
 - Arctic Radio RAC 1.1.5
 - Other Than Air Traffic Services..... RAC 1.2
- “Shall” and “Should” (Definitions)..... GEN 1.1.3
- Shore Markers..... AGA 6.7
- “Should” and “Shall” (Definitions)..... GEN 1.1.3
- SIGMET
(Significant Meteorological Report).... MET 1.1.3, 3.18
- Signals
 - Ground-to-Air SAR 4.8
 - Intercepting and Intercepted Aircraft..... SAR 4.7
 - Marshalling for Aircraft and Helicopters AIR 1.8
 - Visual RAC 4.2.11, 4.4.7
- Significant Weather Prognostic Charts (RAFC)... MET 3.13
- Signs
 - Airside Guidance AGA 5.8
 - Illumination of Airside Guidance..... AGA 5.8.4
 - Mandatory Instruction AGA 5.8.3
 - Operational Guidance AGA 5.8.2
- Simultaneous Operations RAC 4.4.9
- Simultaneous Precision Instrument Approaches
 - Converging Runways..... RAC 9.28
 - Parallel Runways..... RAC 9.27
- Single-engine Aircraft Operating
in Northern Canada..... AIR 2.14.1
 - Transoceanic Flight..... RAC 11.2
- Single Side Band COM 6.3
- Snow
 - Flight Operations in Winter AIR 2.12
 - Landing Seaplanes on Unbroken Snow Conditions
..... AIR 2.12.6
 - Landing Wheel-Equipped Light Aircraft
on Snow Covered Surfaces AIR 2.12.4
 - Removal and Ice Control..... AGA 1.1.5
- Soaring..... COM 5.13.2
- Southern and Northern Domestic Airspace..... RAC 2.2.1
- Southern Control Area
 - Position Reporting Within RAC 12.7.2.3
 - Track System..... RAC 12.7.2
- Sparsely Settled Areas

- Flight Operations AIR 2.14
- Single-Engine Aircraft Operating in Northern Canada.....AIR 2.14.1
- Special VFR Weather Minima RAC 2.7.3
- Speed
 - Adjustment – Radar Controlled Aircraft RAC 9.7.3
 - Aircraft Speed Limit..... RAC 2.5.2
- Spins, Practice AIR 4.3
- Standard
 - Instrument Departure (SID)..... RAC 7.5
 - Pressure Region..... RAC 2.11
 - Radio Telephony..... COM 5.9
 - Terminal Arrival (STAR)..... RAC 9.2
 - Conventional STAR RAC 9.2.1
 - RNAV STAR..... RAC 9.2.2, 9.2.3
- Stop Bars..... AGA 7.14
- Stops, Intermediate..... RAC 3.10
- Stopway
 - Definition AGA 3.6
 - Markings AGA 5.4.2
- Straight-In Approach.....RAC 9.15
- Strength Scale – Communications ChecksCOM 5.10
- Strobe Lights, Use of..... AIR 4.6
- Study, Requirements for an AeronauticalAGA 6.3
- Sunrise/Sunset..... GEN 1.6.2
- Supplement, *AIP Canada (ICAO)* MAP 6.2
- Surface Condition Reports
 - Aircraft Movement (AMSCR) AIR 1.6.4
- Survival SAR 4.8.2
 - Advisory InformationAIR ANNEX

T

- Tactical Air Navigation (TACAN) COM 3.8
- Takeoff Clearance RAC 4.2.8
- Takeoff Distance Available (TODA) AGA 3.8
- Takeoff Minima RAC 9.19.1
- Takeoff Run Available (TORA) AGA 3.8
- Taxi
 - Holding Positions RAC 4.2.6
 - Holding Positions During IFR Operations.. RAC 4.2.7
 - Information RAC 4.2.5
- Taxiing RAC 4.4.4
- Taxiway
 - Bearing Strength..... AGA 3.10
 - Exit and Holding Markings..... AGA 5.4.4
 - Lighting AGA 7.13
 - Rapid-Exit AGA 3.9, 7.12
- TC AIM
 - Amendments–Future datesGEN 1.1.4
 - Content GEN 0–2, 1.1.3
 - Co-ordinator.....GEN 1.1.3
 - Distribution, address changes and information requests..... GEN 0–2, 1.1.4
 - Obtaining the commercial editionGEN 1.1.4
- TCAS/ACAS (Traffic Alert and Collision Avoidance Systems and Airborne Collision Avoidance Systems) RAC 12.16
 - Airworthiness Approval RAC 12.16.5
 - Mode S Transponder Approval

- and Unique CodesRAC 12.16.7
- Operational Approval.....RAC 12.16.4
- Pilot and Controller Interchange.....RAC 12.16.9
- Pilot/Controller ActionsRAC 12.16.8
- Pilot Immunity from Enforcement Action for Deviating from Clearances.....RAC 12.16.6
- Transport Canada Policy..... RAC 12.16.3
- Use of..... RAC 12.16.2
- Use, Recommended..... RAC 12.16.10
- Technical Records, Aircraft LRA 2.6.3
- Temperature Correction
 - for AltimeterRAC Fig. 9.1, AIR 1.5.2
- Terminal Arrival Area (TAA)..... RAC 9.2.5
- Terminal Control Areas..... RAC 2.7.6
- Terminal Products MAP 3.3
- Test Flights, Conduct of Experimental..... AIR 4.2
- Thresholds
 - Displaced, Lighting..... AGA 7.9
 - Displaced, Markings AGA 5.4.1
 - Stopways AGA 5.4.2
- Thunderstorms
 - Flight Operations Near..... AIR 2.7
- Time
 - Signals COM 4.0
 - System GEN 1.6
 - Zone, UTC/Local GEN 1.6.3
- Track System, Southern Control AreaRAC 12.7.2
- Traffic Alert and Collision Avoidance Systems (TCAS) RAC 12.16
- Traffic Circuit Procedures
 - Controlled Aerodromes..... RAC 4.3
 - NORDO/ONLY RAC 4.5.8.2
 - Uncontrolled Aerodromes..... RAC 4.5.2
- Transborder Flights
 - CANPASS – Private Aircraft Program.....FAL 2.3.3
 - Flight Plan Requirements (Between Canada and a Foreign State)..... RAC 3.6.3
 - Private (Airport of Entry) FAL 2.3.2
- Transfer – IFR Units to Towers..... RAC 9.10
- Transoceanic Flight – General Aviation Aircraft.. RAC 11.2
- Transition Areas RAC 2.7.5
 - CMNPS Transition Airspace RAC Fig.12.2
 - RVSM Transition Airspace..... RAC Fig.12.3
- Transponder
 - Alerting SAR 4.4
 - Communication FailureRAC 1.9.7
 - Emergencies RAC 1.9.6
 - IFR Operations in Other Low Level Airspace RAC 1.9.3
 - Mode S, Approval and Unique Codes..... RAC 12.16.7
 - Operation RAC 1.9, 11.14
 - Phraseology RAC 1.9.5
 - Requirements RAC 1.9.2
 - VFR Operations RAC 1.9.4
 - Unlawful Interference (Hijack) RAC 1.9.8
 - Regions – Addresses, Facsimile and Telephone Numbers.....GEN 1.1.1
 - Responsibilities AGA 2.3.3

Transportation Appeal Tribunal of Canada (TATC)..... LRA 6.0

- Refusal to issue or Amend a Canadian Aviation Document LRA 6.2
- Suspension, Cancellation or Refusal to Renew LRA 6.3
- Monetary Penalties LRA 6.4
- Appeals..... LRA 6.5

Transportation Safety Board of Canada (TSB) GEN 3.0

- Addresses, Facsimile and Telephone Numbers..... GEN 3.6

Tribunal – Transportation Appeal Tribunal of Canada (TATC)..... LRA 6.0

True Airspeed (TAS)..... RAC 8.3.2, 11.6.2

Turbulence MET 3.13

- Clear Air (CAT) AIR 2.10
- Reporting Criteria Table MET 3.7
- Pilot Waivers RAC 4.1.1
- Wake..... RAC 4.1.1, AIR 2.9

Turbulence, Downdraft and..... AIR 1.5.7

Turnaround Bay AGA 3.4

Twilight Charts, Morning and Evening GEN 1.6.2

U

Ultra-light Aeroplane AIR 4.10

Uncontrolled Aerodromes

- Aircraft Operations..... RAC 4.5
- Class “G” Airspace
- Recommended Operating Procedures
 - En-Route..... RAC 8.11
 - Helicopter Operations RAC 4.5.3
 - Initial Contact with Air-to-Ground Facility.. RAC 9.11
 - Licensing, Registration and Airworthiness..... LRA 1.0
 - Reporting Procedures (IFR) RAC 9.12
 - Traffic Circuit Procedures RAC 4.5.2

Uncontrolled Airspace – Procedures (IFR) RAC 9.13

Underwater Diving AIR 3.6

UNICOM (Universal Communications)..... RAC 1.2.1

- Approach UNICOM (AU) RAC 1.2.1

Units of Measurement GEN 1.5

Unlawful Interference (Hijack)..... RAC 1.9.8

Unserviceable Area Markings..... AGA 5.7

Upper Level

- Charts (ANAL)..... MET 3.20
- Wind and Temperature Forecasts (FD)..... MET 1.3.8, 3.11

Upper side Band COM 6.3

Use of Numbers COM 5.7

V

V Speeds..... GEN 1.9.1

VASIS (Visual Approach Slope Indicator System)..... AGA 7.6.1 to 7.6.3

VDF (VHF Direction Finder)..... COM 3.10, RAC 1.6, SAR 4.3

Vehicle Control Service (VCS) RAC 1.1.3

Vertigo AIR 3.9

VFR

- Acknowledgement of Clearances..... RAC 5.2
- Aeronautical Information..... MAP 2.0
- Alerting Service RAC 1.1.3
- Altitudes and Flight Levels RAC 5.3
- Controlled Airspace, Use of by VFR Flights..... RAC 2.5.1
- En Route Procedures..... RAC 5.0
- Flight Plan and Flight Itineraries RAC 3.6, 3.7.1
- Holding Procedures..... RAC 4.4.2
- Minimum Altitudes..... RAC 5.4, 5.5
- Operations within Class “C” Airspace RAC 5.8
- Over-the-Top..... RAC 2.7.4
- Position Reporting..... RAC 5.1
- VFR Release of an IFR Aircraft RAC 6.2.2
- Weather Minima RAC 2.7.3, Fig. 2.7

VGM (Voice Generated Module) RAC 4.5.1, 9.12

VHF

- Air Traffic Services COM 5.13.1
- Channel Spacing COM 5.3
- Direction Finding System (VDF) COM 3.10, RAC 1.6, SAR 4.3
- Frequency Allocations COM 5.13
- In Lieu of International HF A/G Frequencies..... COM 6.7
- Omnidirectional Range and Tactical Air Navigation (VORTAC) COM 3.9
- Omnidirectional Range (VOR)..... COM 3.5

Visas and Passports, Requirements for..... FAL 2.2.4, 2.2.5

Visibility, Ground..... RAC 9.19.1

Vision..... AIR 3.7

Visual

- Approach Slope Indicator System (VASIS) AGA 7.6.1 to 7.6.3
- Climb and Descent..... RAC 8.5.2

Visual Climb Over the Airport RAC 7.7.1

Visual Signals..... RAC 4.4.7

- Ground..... RAC 4.2.11
- Ground-to-Air SAR 4.8.1
- Intercepting and Intercepted Aircraft..... SAR 4.7
- Marshalling for Aircraft and Helicopters AIR 1.8
- Tower to Aircraft..... RAC 4.2.11

Voice Generated Module (VGM) RAC 4.5.1, 9.12 MET 3.15.6.2

Voice Systems..... COM 6.1.1

Volcanic Ash MET 2.5, 3.2.2, 3.21

- Flight Operations in AIR 2.6

VOLMET COM 6.2.3, MET 1.4

VOR/DME (RHO-THETA) System..... COM 3.14.1

VORTAC (VHF Omnidirectional Range and Tactical Air Navigation)..... COM 3.9

Vortex

- Characteristics..... AIR 2.9.1
- Strength AIR 2.9

Vortices, Helicopter..... AIR 2.9

VOR

- Airborne VOR Check..... COM 3.5.3
- Check Point COM 3.5.2
- Receiver Checks..... COM 3.5.1

W

Wake TurbulenceRAC 4.1.1, AIR 2.9

Water

- Operations onAIR 2.11
- Operations Over, Life-Saving Equipment .. AIR 2.11.3

Web, Transport Canada Site..... GEN 1.1.4

Weather

- ATC Weather Assistance MET 1.3.8
- ATIS (Automatic Terminal Information Service)..... RAC 1.3, 4.2.1
- Automated Reports – Other MET 3.15.6
- Reports from Other Non-Aviation Autostations..... MET 3.15.6.2
- Voice Generator Module (VGM)MET 3.15.6.1
- Briefing, Flight Planning RAC 3.2
- Centres MET 3.1
- Charts, ReportsMET 3.2.2, 3.2.3
- Codes, significant..... MET 3.15.3
- Flight Operation Near Thunderstorms AIR 2.7
- InformationMET 3.2
- Minima Requirements, Alternate Aerodrome.....RAC 3.14.1
- Minima, VFR.....RAC 2.7.3, Fig. 2.7
- Observations, Surface MET 3.15
- Pilot Report (PIREP) MET 1.1.6, 3.17; RAC 1.1.3, 1.13
- Radar MET 1.3.10
- Radar Network MET 3.16
- Reporting of Cloud Bases MET 1.1.5
- Reports, ChartsMET 3.2.2, 3.2.3
- METAR (Routine Report) MET 3.2.2, 3.15
- Special Reports (SPECI)..... MET 3.15.4
- Surface Maps..... MET 3.19
- Surface Weather Observing Service.....RAC 1.1.3
- Symbols, Significant..... MET 3.19
- TAF (Aerodrome Forecast)MET 3.9
- Volcanic Ash MET 2.5, 3.2.2, 3.21
- Flight Operations in AIR 2.6

Weight and Balance Form RAC 3.5

- Actual Weights..... RAC 3.5.1
- Fuel and Oil Weights..... RAC 3.5.2
- Passenger Standards..... RAC 3.5

Wet RunwaysRAC 4.4.9, AIR 1.6.5

Wheel-Equipped Light Aircraft on Snow-Covered Surfaces..... AIR 2.12.4

WhiteoutAIR 2.12.7

Wildlife, Protection of.....RAC 1.14.2

Wind Direction Indicators (Wind Socks)..... AGA 5.9

Wind

- Pilot Estimate of Surface WindMET 2.6
- Beaufort Wind Scale MET 2.6, Table 1

Wind ShearMET 2.3

- Low Level..... AIR 2.8

Winter Operations – Aircraft Contamination AIR 2.12.2

World Meteorological Organization (WMO) and ICAO

- Applicable Documents MET 1.1.7

121.5 MHz, Monitoring of
Emergency Frequency COM 5.12

126.7 MHz, Monitoring of..... RAC 5.1

5680 kHz, Use of FrequencyCOM 5.14

5.0 MISCELLANEOUS

5.1 GLOSSARY OF AERONAUTICAL TERMS

“Acknowledge”

An expression used in radiocommunication meaning “Let me know that you have received and understood this message.”

active runway

Other expression for: runway in use

advanced ultralight aeroplane

An aeroplane that has a type design that is in compliance with the standards specified in the manual entitled *Design Standards for Advanced Ultra-light Aeroplanes*.

aerodrome

Any area of land, water (including the frozen surface thereof) or other supporting surface used, designed, prepared, equipped or set apart for use, either in whole or in part, for the arrival, departure, movement or servicing of aircraft. This includes any buildings, installations and equipment situated thereon or associated therewith.

airborne collision avoidance system (ACAS)

An aircraft system based on secondary surveillance radar (SSR) transponder signals which operates independently of ground-based equipment to provide advice to the pilot on potential conflicting aircraft that are equipped with SSR transponders.

aircraft parachute system

A device used to decelerate the free-fall of an aircraft by creating drag through the atmosphere.

air defence identification zone (ADIZ)

An airspace of defined dimensions extending upwards from the surface of the earth within which certain rules for the security control of air traffic apply.

airport (APRT)

An aerodrome for which an airport certificate is in force.

airspace classification (see RAC 2.8).

The division of the Canadian Domestic Airspace (CDA) into seven classes, each identified by a single letter: A, B, C, D, E, F or G. The application of any classification to an airspace structure determines the operating rules, the level of ATC service provided within the structure and, in some instances, communications and equipment requirements. The horizontal and vertical limits of airspace are described in the *Designated Airspace Handbook* (DAH).

air traffic

All aircraft in flight or operating on the manoeuvring area of an aerodrome.

air traffic control clearance

An authorization issued by an ATC unit for an aircraft to proceed within controlled airspace in accordance with the conditions specified by that unit.

- **also called:** air traffic clearance, ATC clearance and clearance

air traffic control instruction

A directive issued by an ATC unit for ATC purposes.

air traffic control service

A service provided for the purposes of

- (a) preventing collisions between
 - (i) aircraft;
 - (ii) aircraft and obstacles; and
 - (iii) aircraft and vehicles on the manoeuvring area; and
- (b) expediting and maintaining an orderly flow of air traffic.
 - **also called:** ATC service

air traffic control unit

As the circumstances require, this may be

- (a) an area control centre (ACC) established to provide ATC service to aircraft; or
- (b) an airport control tower unit established to provide ATC service to airport traffic.
 - **also called:** ATC unit

alternate aerodrome

An aerodrome to which an aircraft may proceed when it becomes either impossible or inadvisable to proceed to or land at the aerodrome of intended landing. Alternate aerodromes include the following:

- (a) takeoff alternate aerodrome
- (b) en-route alternate aerodrome
- (c) destination alternate aerodrome

NOTE: The aerodrome from which a flight departs may also be an en-route or a destination alternate aerodrome for that flight.

apron

That part of an aerodrome, other than the manoeuvring area, intended to accommodate the loading and unloading of passengers and cargo; the refuelling, servicing, maintenance and parking of aircraft; and any movement of aircraft, vehicles and pedestrians engaged in services for such purposes.

- **also called:** flight line, ramp and tarmac

arc

The track over the ground of an aircraft flying at a constant distance from a NAVAID by reference to distance measuring equipment (DME).

Arctic Control Area (ACA) (see RAC Figure 2.3)

A controlled airspace within the Northern Domestic Airspace (NDA) at FL 270 and above.

area minimum altitude (AMA)

The lowest altitude to be used under instrument meteorological conditions (IMC) that will provide a minimum vertical clearance of 1 000 ft or, in designated mountainous terrain, 2 000 ft above all obstacles located in the area specified, rounded up to the nearest 100-ft increment.

area navigation (RNAV)

A method of navigation which permits aircraft operation on any desired flight path within the coverage of ground- or space-based NAVAIDs or within the limits of the capability of self-contained aids, or a combination of these.

ballistic parachute system

An aircraft parachute system that extracts/propels the parachute via an ignitable propellant (e.g. rocket motor or explosive charge).

basic ultralight aeroplane

An aeroplane having no more than two seats, designed and manufactured to have

- (a) a maximum take-off weight not exceeding 544 kg, and
- (b) a stall speed in the landing configuration (V_{so}) of 39 kt (45 mph) indicated airspeed, or less, at the maximum take-off weight.

broadcast (BCST)

A transmission of information relating to air navigation that is not addressed to a specific station or stations.

Canadian Domestic Airspace (CDA)

As geographically delineated in the *Designated Airspace Handbook* (DAH), all airspace over the Canadian land mass, the Canadian Arctic and the Canadian archipelago, and over areas of the high seas.

ceiling

The lesser of:

- (a) the height above ground or water of the base of the lowest layer of cloud covering more than half the sky; or
- (b) the vertical visibility in a surface-based layer which completely obscures the sky.

clearance limit

The point to which an aircraft is granted an ATC clearance.

“Cleared for the option”

For an arriving aircraft: An expression used to indicate ATC authorization for an aircraft to make a touch-and-go, low approach, missed approach (MA), stop-and-go, or full-stop landing, at the discretion of the pilot.

For a departing aircraft: An expression used to indicate ATC authorization for an aircraft to execute manoeuvres other than a normal takeoff (e.g. an aborted takeoff). After such a manoeuvre, the pilot is expected to exit the runway by the most expeditious way rather than backtrack the runway.

composite flight plan

A flight plan (FP) that specifies VFR operation for one portion of flight and IFR for another portion.

contact approach

An approach wherein an aircraft on an IFR flight plan (FP), having an ATC authorization and operating clear of clouds with at least 1 mi. flight visibility and a reasonable expectation of continuing to the destination airport in those conditions, may deviate from the instrument approach procedure (IAP) and proceed to the destination airport by visual reference to the surface of the earth.

control area extension (CAE)

A controlled airspace of defined dimensions within the low level airspace (LLA), extending upwards from 2 200 ft AGL unless otherwise specified.

controlled airspace

An airspace of defined dimensions within which ATC service is provided.

controlled VFR flight (CVFR)

A flight conducted under VFR within Class B airspace and in accordance with an ATC clearance.

control zone (CZ)

A controlled airspace of defined dimensions extending upwards from the surface of the earth up to and including 3 000 ft AAE unless otherwise specified.

cruise climb

A cruising technique resulting in a net increase in altitude as the aircraft mass decreases. A clearance or instruction to carry out a cruise climb authorizes temporary levelling at intermediate altitudes and climb at any given rate.

cruising altitude

The altitude, as shown by a constant altimeter indication in relation to a fixed and defined datum, maintained during a flight or portion thereof.

daylight

The period of time during any day that begins with the morning civil twilight and ends with the evening civil twilight.

dead reckoning navigation (DR)

The estimating or determining of position by advancing an earlier known position by the application of direction, time and speed data.

decision altitude (DA)

A specified altitude in the precision approach or approach with vertical guidance at which a missed approach must be initiated if the required visual reference to continue the approach to land has not been established.

NOTE: Decision altitude (DA) is referenced to mean sea level (MSL) and decision height (DH) is referenced to the threshold elevation.

decision height (DH)

A specified height in the precision approach or approach with vertical guidance at which a missed approach must be initiated if the required visual reference to continue the approach to land has not been established.

NOTE: Decision height (DH) is referenced to the threshold elevation and decision altitude (DA) is referenced to mean sea level (MSL).

defence visual flight rules (DVFR)

Rules applicable to flights within an air defence identification zone (ADIZ) conducted under VFR.

Direct User Access Terminal System (DUATS)

A computer-based system provided by a vendor to pilots or other operational personnel. DUATS supplies the aviation weather and NOTAM information necessary for pre-flight planning via computer terminals or personal computers owned by the vendor or users.

downwind termination waypoint (DTW)

The waypoint located downwind to the landing runway abeam the final approach course fix (FACF) where an open RNAV STAR terminates.

evening civil twilight

Relative to the standard meridians of the time zones, the period of time that begins at sunset and ends at the time specified by the Institute of National Measurement Standards of the National Research Council of Canada.

NOTE: Evening civil twilight ends in the evening when the centre of the sun's disc is 6° below the horizon.

expected approach time (EAT)

The time at which ATC expects that an arriving aircraft, following a delay, will leave the holding fix to complete its approach for landing.

expected further clearance time (EFC)

The time at which it is expected that further clearance will be issued to an aircraft.

expedite (to)

An expression used by ATC when prompt compliance is required to avoid the development of an imminent situation.

final approach area

The area within which the final approach portion of an instrument approach procedure (IAP) is carried out.

final approach course fix (FACF)

A fix and/or waypoint located on the final approach course of an instrument approach procedure (IAP)

- (a) prior to the point of glide path (GP) intercept on a precision approach procedure;
- (b) prior to the final approach fix (FAF) on a non-precision approach procedure that has a designated FAF;
- (c) prior to any stepdown fixes on a non-precision approach procedure with designated fixes but no FAF; or
- (d) at a point that would permit a normal landing approach on a non-precision approach procedure with no FAF or stepdown fixes.

final approach fix (FAF)

The fix of a non-precision instrument approach procedure (IAP) where the final approach segment commences.

final approach segment

That part of an instrument approach procedure (IAP) from the time that the aircraft

- (a) completes the last procedure turn or base turn, where one is specified;
- (b) crosses the final approach fix (FAF), waypoint or point; or
- (c) intercepts the last track specified for the procedure

until it reaches the missed approach point (MAP). It is in this part of the procedure that alignment and descent for landing are accomplished.

- **also called:** final approach

flight information centre (FIC)

A centralized ATS unit that provides services pertinent to pre-flight and the en-route phase of flight.

flight information region (FIR) (see RAC Figure 2.2)

An airspace of defined dimensions extending upwards from the surface of the earth within which flight information service (FIS) and alerting service are provided.

flight information service en route (FISE)

The provision and receipt by an FIC of information pertinent to the en route phase of flight.

flight level (FL)

The altitude expressed in hundreds of feet indicated on an altimeter set to 29.92 in. of mercury or 1013.2 mb.

flight management system (FMS)

An aircraft computer system that uses a large database to allow routes to be programmed and fed into the system by means of data loader. The system is constantly updated with regard to position accuracy by reference to conventional NAVAIDs.

flight service station (FSS)

An ATS unit that provides services pertinent to the arrival and departure phases of flight at uncontrolled aerodromes and for transit through a mandatory frequency (MF) area.

flight visibility

The average range of forward visibility at any given time from the cockpit of an aircraft in flight.

flow control

Measures designed to adjust the flow of traffic into a given airspace, along a given route, or bound for a given aerodrome, so as to ensure the most effective utilization of the airspace.

fuel dumping

The intentional airborne release of usable fuel. This does not include the dropping of fuel tanks.

fuel remaining

The amount of fuel remaining on board until actual fuel exhaustion.

“Go around”

An expression used in radiocommunications to instruct a pilot to abandon an approach or landing.

ground visibility

In respect of an aerodrome, the visibility at that aerodrome as contained in a weather observation reported by

- (a) an ATC unit;
- (b) an FSS or FIC;
- (c) a community aerodrome radio station (CARS);
- (d) an automated weather observation system (AWOS) used by the Department of Transport, the Department of National Defence or the Atmospheric Environment Service for the purpose of making aviation weather observations; or
- (e) a radio station that is ground-based and operated by an air operator.

hang glider

A motorless heavier-than-air aircraft deriving its lift from surfaces that remain fixed in flight, designed to carry not more than two persons and having a launch weight of 45 kg (100 lb) or less.

“Have numbers”

An expression used by pilots to indicate that they have received runway, wind and altimeter information only.

heading (HDG)

The direction in which the longitudinal axis of an aircraft is pointed, usually expressed in degrees from north (true, magnetic, compass or grid north).

height above aerodrome (HAA)

The height in feet of the minimum descent altitude (MDA) above the published aerodrome elevation.

height above touchdown zone elevation

The height in feet of the decision height (DH) or the minimum descent altitude (MDA) above the touchdown zone elevation (TDZE).

- **also called:** height above touchdown (HAT) and height above touchdown zone

high intensity runway operations (HIRO)

Operations, used at very busy airports, that consist of optimizing separation of aircraft in final approach in order to minimize runway occupancy time (ROT) for both arriving and departing aircraft and to increase runway capacity.

high level air route

In high level airspace (HLA), a prescribed track between specified fixes.

NOTE: On aeronautical charts, high level air routes are indicated by letters such as “T” or “NAT.”

high level airspace (HLA)

All airspace within the Canadian Domestic Airspace (CDA) at or above 18 000 ft ASL.

high level airway

In controlled high level airspace (HLA), a prescribed track between specified fixes.

NOTE: On aeronautical charts, high level airways are indicated by the letter “J” (e.g. J500).

initial approach segment

That part of an instrument approach procedure (IAP) between the initial approach fix (IAF) or waypoint and the intermediate approach fix (IF) or waypoint during which the aircraft departs the en route phase of flight and manoeuvres to enter the intermediate segment.

- **also called:** initial approach

instrument approach procedure (IAP)

A series of predetermined manoeuvres by reference to flight instruments with specified protection from obstacles from the initial approach fix (IAF), or where applicable, from the

beginning of a defined arrival route to a point from which a landing can be completed and thereafter, if a landing is not completed, to a position at which holding or en route obstacle clearance criteria apply.

- **also called:** instrument approach

instrument meteorological conditions (IMC)

Meteorological conditions less than the minima specified in Subpart 602 of the *Canadian Aviation Regulations* (CARs) for visual meteorological conditions (VMC), expressed in terms of visibility and distance from cloud.

intermediate approach segment

That part of an instrument approach procedure (IAP) between the intermediate approach fix (IF) or waypoint and the final approach fix (FAF), waypoint or point, or between the end of a track reversal, racetrack or dead-reckoning track procedure and the FAF, waypoint or point, as appropriate. It is in this part of the procedure that aircraft configuration, speed and positioning adjustments are made for entry into the final approach segment.

- **also called:** intermediate approach

intersection (INTXN)

As the circumstances require, this may be

- a point on the surface of the earth over which two or more position lines intersect. The position lines may be true bearings from non-directional beacons (NDB) (magnetic bearings shown on chart for pilot usage); radials from VHF/UHF NAVAIDs; centrelines of airways, fixed RNAV routes or air routes; localizers; or DME distances; or
- the point where two runways, a runway and a taxiway, or two taxiways cross or meet.

Land and Hold Short Operations (LAHSO)

Operations that include simultaneous takeoffs and landings and/or simultaneous landings when a landing aircraft is able and is instructed by the controller to hold short of the intersecting runway/taxiway or designated hold-short point.

NOTE: This term replaces the term *Simultaneous Intersecting Runway Operations* (SIRO)

low approach

An approach over an airport or runway following an instrument approach procedure (IAP) or VFR approach, including the overshoot manoeuvre, where the pilot intentionally does not make contact with the runway.

low level air route

Within low level uncontrolled airspace, a route extending upwards from the surface of the earth and for which ATC service is not provided.

low level airspace (LLA)

All airspace within the Canadian Domestic Airspace (CDA) below 18 000 ft ASL.

low level airway

Within controlled low level airspace (LLA), a route extending upwards from 2 200 ft above the surface of the earth and for which ATC service is provided.

L-routes

L-routes are low-level uncontrolled fixed RNAV routes depicted on En Route Low Altitude charts using green dashed lines and require GNSS RNAV systems for use. The MOCA provides obstacle protection for only 6 NM either side of the track centreline and does not splay.

magnetic reference bearing (MRB)

Magnetic reference bearing (MRB) is the published bearing between two waypoints on a fixed RNAV route and will be published within the SDA. The MRB is calculated by applying magnetic variation at the waypoint to the calculated true course between two waypoints. Pilots should use this bearing as a reference only, because RNAV systems will fly the true course between the waypoints. True reference bearings (TRB) will be published along fixed RNAV routes located in the NDA and shall be notated with the suffix “T”.

mandatory frequency (MF)

A very high frequency (VHF) specified in the *Canada Air Pilot* (CAP), the *Canada Flight Supplement* (CFS) or the *Canada Water Aerodrome Supplement* (CWAS) for the use of radio-equipped aircraft operating within a mandatory frequency (MF) area.

manoeuvring area

The part of an aerodrome, other than an apron, that is intended to be used for the takeoff and landing of aircraft and for the movement of aircraft associated with takeoff and landing.

MEDEVAC

An expression used to request ATS priority handling for a medical evacuation flight based on a medical emergency in the transport of patients, organ donors, organs, or other urgently needed life-saving medical material. This expression is to be used on flight plans (FP) and in radiotelephony communications if a pilot determines that a priority is required.

military operations area (MOA)

An airspace of defined dimensions established to segregate certain military activities from IFR traffic and to identify, for VFR traffic, where these activities are conducted.

military terminal control area (MTCA)

A controlled airspace of defined dimensions normally established in the vicinity of a military aerodrome and within which special procedures and exemptions exist for military aircraft. The terminology (Class B, C, D or E equivalent) used for the designations of MTCAs describes the equivalent level

of service and operating rules for civilian aircraft operating within the MTCA and under military control.

minimum descent altitude (MDA)

The altitude above sea level (ASL) specified in the *Canada Air Pilot* (CAP) or the route and approach inventory for a non-precision approach, below which descent shall not be made until the required visual reference to continue the approach to land has been established.

minimum en route altitude (MEA)

The altitude above sea level (ASL) between specified fixes on airways or air routes that assures acceptable navigational signal coverage and that meets the IFR obstacle clearance requirements.

NOTE: This altitude is published on aeronautical charts.

minimum fuel

An expression used to inform ATC that an aircraft’s fuel supply has reached a state that is sufficient to reach destination, provided that unexpected delays are not encountered.

minimum holding altitude (MHA)

The lowest altitude prescribed for a holding pattern that assures navigational signal coverage, communications, and meets obstacle clearance requirements.

minimum IFR altitude

The lowest IFR altitude established for use in a specific airspace. Depending on the airspace concerned, the minimum IFR altitude may be a minimum obstacle clearance altitude (MOCA), a minimum en route altitude (MEA), a minimum sector altitude (MSA), a minimum vectoring altitude (MVA), a safe altitude 100 NM, an area minimum altitude (AMA), a transition altitude or a missed approach altitude. The minimum IFR altitude provides obstacle clearance but may or may not be within controlled airspace.

minimum obstacle clearance altitude (MOCA)

The altitude above sea level (ASL) between specified fixes on airways or air routes that meets the IFR obstacle clearance requirements for the route segment in question.

NOTE: This altitude is published on aeronautical charts.

minimum reception altitude (MRA)

When applied to a specific VHF/UHF intersection, the lowest altitude above sea level (ASL) at which acceptable navigational signal coverage is received to determine the intersection.

minimum sector altitude (MSA)

The lowest altitude that may be used that will provide a minimum clearance of 1 000 ft, under conditions of standard temperature and pressure, above all obstacles located within a sector of a circle having a radius of at least 25 NM centred on a radio aid to navigation or on a waypoint located near the aerodrome.

minimum vectoring altitude (MVA)

The lowest altitude for vectoring aircraft by ATC that meets obstacle clearance and radio coverage requirements in the airspace specified.

missed approach point (MAP)

The point on the final approach course that signifies the termination of the final approach and the commencement of the missed approach segment. It may be

- (a) the intersection of an electronic glide path (GP) with a decision height (DH);
- (b) a NAVAID located on the aerodrome;
- (c) a suitable fix (e.g. distance measuring equipment [DME]); or
- (d) a specified distance beyond the NAVAID or final approach fix (FAF), not to exceed the distance from that NAVAID or fix to the nearest boundary of the aerodrome.

missed approach segment

That part of an instrument approach procedure (IAP) between the missed approach point (MAP), the missed approach waypoint (MAWP), or the point of arrival at decision height (DH), and the specified missed approach NAVAID, intersection, fix or waypoint, as appropriate, at the minimum IFR altitude. It is in this part of the approach procedure that the aircraft climbs and returns to the en route structure or is positioned for holding or a subsequent approach. The route of flight and altitudes are depicted on instrument approach charts.

- **also called:** missed approach (MA)

morning civil twilight

Relative to the standard meridians of the time zones, the period of time that begins at the time specified by the Institute for National Measurement Standards of the National Research Council of Canada and ends at sunrise.

NOTE: Morning civil twilight begins in the morning when the centre of the sun's disc is 6° below the horizon.

mountainous region (see RAC Figure 2.10)

An area of defined lateral dimensions above which special rules concerning minimum en route altitude (MEA) apply.

movement area

The part of an aerodrome that is intended to be used for the surface movement of aircraft and that includes the manoeuvring area and aprons.

navigation aid (NAVAID)

Any visual or electronic device, airborne or on the surface of the earth, that provides point-to-point guidance information or position data to aircraft in flight.

- **also called:** navigational aid

night

The period of time during any day that starts at the end of evening civil twilight and ends at the start of morning civil twilight.

non-precision approach procedure

An instrument approach procedure (IAP) in which only electronic azimuth information is provided. No electronic glide path (GP) information is provided and obstacle assessment in the final segment is based on minimum descent altitude (MDA).

non-RVSM aircraft

An aircraft that does not meet reduced vertical separation minimum (RVSM) requirements for certification and/or for operator approval.

Northern Control Area (NCA) (see RAC Figure 2.3)

A controlled airspace within the Northern Domestic Airspace (NDA) at FL230 and above.

Northern Domestic Airspace (NDA) (see RAC Figure 2.1)

As geographically delineated in the *Designated Airspace Handbook* (DAH), a subdivision of Canadian Domestic Airspace (CDA) commencing at the North Pole and extending southward to the northern limit of the Southern Domestic Airspace (SDA).

North Warning System (NWS) (see COM 6.6.4)

A system that provides airspace surveillance and command and control capability for air defence identification over the northern approaches to the continent. It consists of 15 long-range radars (LRR) and 39 short-range radars (SRR) across the Canadian Arctic and Alaska. Systems deployed on Canadian territory are operated and maintained by Canada for the North American Aerospace Defence Command (NORAD) on behalf of Canada and the United States.

NOTAM

A notice distributed by means of telecommunication containing information concerning the establishment, condition or change in any aeronautical facility, service, procedure or hazard, the timely knowledge of which is essential to personnel concerned with flight operations.

obstacle (OBST)

All fixed (whether temporary or permanent) and mobile objects, or parts thereof, that are located on an area intended for the surface movement of aircraft or that extend above a defined surface intended to protect aircraft in flight.

- **also called:** obstruction

pavement classification number (PCN)

Numbers expressing, in ICAO terminology, the bearing strength of a pavement for unrestricted operations in a similar fashion to Transport Canada's pavement load rating (PLR).

precision approach radar (PAR)

A high-definition, short-range radar used as an approach aid. This system provides the controller with altitude, azimuth and range information of high accuracy for the purpose of assisting

the pilot in executing an approach and landing. This form of navigation assistance is termed “precision radar approach”.

preferential runway

One or more runways designated and published by the airport operator whose selection directs aircraft away from noise-sensitive areas during the initial departure and final approach phases of flight. Designation of preferential runways may be governed by time restrictions, weather, runway conditions, airport layout, aircraft routings or capacity maximization.

preferred runway

At an uncontrolled aerodrome, the most suitable operational runway, taking into consideration wind direction and speed, noise abatement restrictions, runway conditions, ground traffic, and any other relevant factor or restriction.

procedure turn (PT)

A manoeuvre in which a turn is made away from a designated track followed by a turn in the opposite direction to permit the aircraft to intercept and proceed along the reciprocal of the designated track.

procedure turn inbound

The point of a procedure turn manoeuvre where course reversal has been completed and an aircraft is established inbound on the intermediate approach or final approach course. A report of “procedure turn inbound” is normally used by ATC as a position report for separation purposes.

progressive taxi

Precise taxi instructions given to a pilot unfamiliar with the aerodrome or issued in stages as the aircraft proceeds along the taxi route.

Q-routes

Q-routes are high-level fixed RNAV routes depicted on En Route High Altitude charts using black dashed lines and require an RNAV system with performance capabilities currently only met by GNSS or distance measuring equipment/inertial reference unit (DME/DME/IRU) systems. DME/DME/IRU navigation may be limited in some parts of Canada owing to navigational facility coverage. In such cases, the routes will be annotated as “GNSS only” on the chart.

radar identification

The process of ascertaining that a particular target is the radar echo from a specific aircraft.

“Radar identified”

An expression used by ATC to inform the pilot of an aircraft when radar identification is established.

RADAR REQUIRED

Annotation used on an instrument approach chart to indicate that the procedure turn may have been eliminated and that the initial approach portion of the procedure is being provided by ATC vectors. Without ATC vectoring, the instrument approach procedure (IAP) may not have a published initial approach.

radial (R)

A magnetic bearing from a VHF omnidirectional range (VOR), tactical air navigation aid (TACAN), or VORTAC facility, except for facilities in the Northern Domestic Airspace (NDA), which may be oriented on true or grid north.

reduced vertical separation minimum (RVSM)

The application of 1 000-ft vertical separation at and above FL290 between RVSM certified aircraft operating in designated airspace.

required visual reference

In respect of an aircraft on an approach to a runway, the section of the approach area of the runway or the visual aids that, when viewed by the pilot of the aircraft, enable the pilot to make an assessment of the aircraft position and the rate of change of position relative to the nominal flight path in order to continue the approach and complete the landing.

restricted area

Class F airspace of defined dimensions above the land areas or territorial waters within which the flight of aircraft is restricted in accordance with certain specified conditions.

runway heading

The magnetic or true direction that corresponds with the runway centreline rather than the painted runway numbers.

runway incursion

Any occurrence at an aerodrome involving the incorrect presence of an aircraft, vehicle, or person on the protected area of a surface designated for the landing and takeoff of aircraft.

runway in use

Any runway currently being used for takeoff or landing. When multiple runways are used, they are all considered runways in use.

- **also called:** active runway

RVSM Aircraft

An aircraft that meets reduced vertical separation minimum (RVSM) requirements for certification and for operator approval.

safety alert

A notification by an air traffic controller to an aircraft that it is in a position which, in the controller’s judgment, is in unsafe proximity to terrain, obstructions or other aircraft.

secondary surveillance radar (SSR)

A radar system that requires complementary aircraft equipment (transponder). The transponder generates a coded reply signal in response to transmissions from the ground station (interrogator). Since this system relies on transponder-generated signals rather than signals reflected from the aircraft, as in primary surveillance radar, it offers significant operational advantages such as increased range and positive identification.

shuttle procedure

A manoeuvre involving a descent or climb in a pattern resembling a holding pattern.

Southern Control Area (SCA) (see RAC Figure 2.3)

A controlled airspace within the Southern Domestic Airspace (SDA) at 18 000 ft ASL and above.

Southern Domestic Airspace (SDA) (see RAC Figure 2.1)

As geographically delineated in the *Designated Airspace Handbook* (DAH), all airspace within the Canadian Domestic Airspace (CDA) commencing at the Canada-United States border and extending northward to the southern limit of the Northern Domestic Airspace (NDA).

“Squawk ident”

A request for a pilot to activate the aircraft transponder identification feature.

standard instrument departure (SID)

An IFR ATC departure procedure published in the *Canada Air Pilot* (CAP) for pilot and controller use. SIDs may be either:

- (a) pilot navigation SIDs: SIDs where the pilot is required to use the applicable SID chart as reference for navigation to the en route phase; or
- (b) vector SIDs: SIDs established where ATC will provide radar navigational guidance to a filed or assigned route, or to a fix depicted on the applicable SID chart. Pilots are expected to use the SID chart as a reference for navigation until the vector is commenced.

standard terminal arrival (STAR)

An IFR ATC arrival procedure published in the *Canada Air Pilot* (CAP) for pilot and controller use.

stepdown fix

A fix permitting additional descent within a segment of an instrument approach procedure (IAP) by identifying the point at which a controlling obstacle has been safely overflown.

stop-and-go

A procedure in which an aircraft lands, makes a complete stop on the runway, and then commences a takeoff from that point.

straight-in approach

- (1) A VFR approach in which the aircraft enters the aerodrome traffic circuit on the final leg without having executed any other part of the circuit.
- (2) An IFR approach in which the aircraft begins the final approach without first having executed a procedure turn (PT).

terminal arrival area (TAA)

An area depicted on select GNSS approach charts that indicates altitudes that provide a minimum clearance of 1 000 ft above all obstacles. The area is bounded by tracks and distances to identified waypoints.

terminal control area (TCA)

A controlled airspace of defined dimensions that is normally established in the vicinity of one or more major aerodromes and within which ATC service is provided based on the airspace classification.

threshold

The beginning of the portion of the runway usable for landing.

threshold crossing height (TCH)

The height of the glide path (GP) above the runway threshold.

touch-and-go

A procedure in which an aircraft lands and then commences a takeoff without stopping.

touchdown zone (TDZ)

The first 3 000 ft of the runway or the first third of the runway, whichever is less, measured from the threshold in the direction of landing.

touchdown zone elevation (TDZE)

The highest centreline elevation in the touchdown zone.

track

The projection on the earth's surface of the path of an aircraft, the direction of which path at any point is usually expressed in degrees from true, magnetic or grid north.

transition

- (1) The general term that describes the change from one phase of flight or flight conditions to another, e.g. transition from en route flight to the approach or transition from instrument flight to visual flight.
- (2) A published procedure used to connect the basic standard instrument departure (SID) to one or more en route airways or to connect one or more en route airways to the basic standard terminal arrival (STAR). More than one transition may be published in the associated SID or STAR.
- (3) Other expression for: feeder route

True reference bearings (TRB)

True reference bearings (TRB) will be published along fixed RNAV routes located in the NDA and shall be notated with the suffix “T.”

T-routes

T-routes are low-level controlled fixed RNAV routes depicted on En Route Low Altitude charts using black dashed lines and require GNSS RNAV systems for use. The airspace associated with T-routes extends upward from 2 200 ft AGL, 10 NM either side of the centreline, and does not splay. The MOCA provides obstacle protection for only 6 NM either side of the track centreline and does not splay.

ultralight aeroplane

An advanced ultra-light aeroplane or a basic ultralight aeroplane.

vector

A heading given by a controller to a pilot on the basis of radar-derived information to provide navigational guidance.

also called: radar vectoring

visual approach

An approach wherein an aircraft on an IFR flight plan (FP), operating in visual meteorological conditions (VMC) under the control of ATC and having ATC authorization, may proceed to the airport of destination.

visual meteorological conditions (VMC)

Meteorological conditions, expressed in terms of visibility and distance from cloud, equal to or greater than the minima specified in CAR 602.

visual separation

A means used by controllers to separate aircraft operating in visual meteorological conditions (VMC).

- (a) VFR—The controller, having determined that a potential conflict exists, issues clearances, instructions and/or information as necessary to aid aircraft in establishing visual contact with each other or to assist aircraft in avoiding other aircraft.
- (b) IFR or CVFR—Following a pilot’s report that the traffic is in sight, the controller issues the clearance and instructs the pilot to provide his or her own separation by manoeuvring the aircraft as necessary to avoid or follow the traffic.

waypoint (WP)

A specified geographical location, defined by longitude and latitude, that is used in the definition of routes and terminal segments and for progress-reporting purposes.

“When ready...”

Authorization for an aircraft to comply with a clearance or instruction at some point in the future when convenient.

wind shear (WS)

A change in wind speed and/or wind direction in a short distance. It can exist in a horizontal or vertical direction and occasionally in both.

5.2 ABBREVIATIONS AND ACRONYMS

- A AE.....above aerodrome elevation
- AAIR Annual Airworthiness Information Report
- ACAArctic Control Area
- ACAS..... airborne collision avoidance system
- ACC area control centre
- ADCUS..... “Advise customs”
- ADF automatic direction finder
- ADIZ..... air defence identification zone
- AFS aeronautical fixed service
- AFTN..... aeronautical fixed telecommunications network
- A/G air-to-ground
- AGL above ground level
- AICaeronautical information circular
- AIPAeronautical Information Publication
- AIRAC ...Aeronautical Information Regulation and Control
- AIREP air report
- AISaeronautical information service
- AMamplitude modulation
- AMA..... area minimum altitude
- AMEaircraft maintenance engineer
- AMISaircraft movement information service
- AOE airport of entry
- AOM airport operations manual
- APAPI..... abbreviated precision approach path indicator
- APVapproach procedure with vertical guidance
- ARCAL aircraft radio control of aerodrome lighting
- ARFF Aircraft Rescue and Fire Fighting
- ARPaerodrome reference point
- ASDA..... accelerate-stop distance available
- ASDE airport surface detection equipment
- ASLabove sea level
- ATC air traffic control
- ATF aerodrome traffic frequency
- ATFM air traffic flow management
- ATIS.....automatic terminal information service
- ATS air traffic service
- AU approach UNICOM
- AWOS automated weather observation system
- BCST broadcast
- C Celsius
- CADORS Civil Aviation Daily Occurrence Reporting System
- CAE control area extension
- CAP *Canada Air Pilot*
- CARs *Canadian Aviation Regulations*
- CARAC...Canadian Aviation Regulation Advisory Council
- CARS..... community aerodrome radio station
- CATclear air turbulence
- CAT I, II, III Category I, II, III
- CAVOK..... ceiling and visibility OK
- CDACanadian Domestic Airspace
- CFB Canadian Forces base
- CFS *Canada Flight Supplement*
- CG centre of gravity
- CMA Central Monitoring Agency
- CMC Canadian Meteorological Centre

CMNPS Canadian minimum navigation performance specifications	HI Enroute High Altitude Chart
CMNPSA Canadian minimum navigation performance specifications airspace	HIAL high intensity approach lighting
C of A certificate of airworthiness	HMU height monitoring unit
C of R certificate of registration	hPa hectopascal
C.R.C. Consolidated Regulations of Canada	Hz hertz
CRFI Canadian Runway Friction Index	IAF initial approach fix
CTA control area	IAP instrument approach procedure
CVFR controlled VFR	IAS indicated airspeed
CWAS <i>Canada Water Aerodrome Supplement</i>	ICAO International Civil Aviation Organization
CZ control zone	IF intermediate fix
DA decision altitude	IFR instrument flight rules
DAH <i>Designated Airspace Handbook (TP 1820E)</i>	ILS instrument landing system
DCPC direct controller-pilot communications	IMC instrument meteorological conditions
DF direction finder	INF inland navigation fix
DH decision height	INS inertial navigation system
DME distance measuring equipment	IRS inertial reference system
DND Department of National Defence	ISA International Standard Atmosphere
DR dead reckoning navigation	J or JET high level airway
DRCO dial-up remote communications outlet	JRCC joint rescue co-ordination centre
DST daylight saving time	kg kilogram
DTW downwind termination waypoint	kHz kilohertz
DUATS Direct User Access Terminal System	kN kilonewton
DVFR defence visual flight rules	kt knot
E east	LAHSO Land and Hold Short Operations
EAT expected approach time	lb pound
EC Environment Canada	LDA landing distance available
EET estimated elapsed time	LF low frequency
EFC expected further clearance time	LIAL low intensity approach lighting
ELT emergency locator transmitter	LO Enroute Low Altitude Chart
ERS Emergency Response Service	LOC localizer
ESCAT Plan Emergency Security Control of Air Traffic Plan	LWIS limited weather information system
EST Eastern Standard Time	MA missed approach
ETA estimated time of arrival	MALSF medium intensity approach lighting system with sequenced flashing lights
ETD estimated time of departure	MALS medium intensity approach lighting system with runway alignment indicator lights
ETE estimated time en route	MANOT missing aircraft notice
EWH eye-to-wheel height	MAP missed approach point
FAA Federal Aviation Administration (USA)	MASPS minimum aircraft system performance specification
FACF final approach course fix	mb millibar
FAF final approach fix	MDA minimum descent altitude
FARs <i>Federal Aviation Regulations (USA)</i>	MEA minimum en route altitude
FATO final approach and take-off area	MEDEVAC medical evacuation flight
FIC flight information centre	METAR aerodrome routine meteorological report
FIR flight information region	MF mandatory frequency
FISE flight information service en route	MFAU Military Flight Advisory Unit
FL flight level	MHA minimum holding altitude
FMS flight management system	MHz megahertz
FSS flight service station	MLS microwave landing system
GHz gigahertz	MM middle marker
GMU GPS monitoring unit	MNPS minimum navigation performance specifications
GNSS global navigation satellite system	MNPSA minimum navigation performance specifications airspace
GPS global positioning system	MOA military operations area
hr hour	MOCA minimum obstacle clearance altitude
HAA height above aerodrome	MPa megapascal
HAT height above touchdown	mph miles per hour
HF high frequency	MRA minimum reception altitude
Hg mercury	

MRB	magnetic reference bearing	RVR	runway visual range
MSA	minimum sector altitude	RVSM	reduced vertical separation minimum
MTCA	military terminal control area	S	south
MVA	minimum vectoring altitude	SAR	search and rescue
N	north	SCA	Southern Control Area
NAARMO	North American Approvals Registry and Monitoring Organization	SDA	Southern Domestic Airspace
NADP	noise abatement departure procedure	SELCAL	selective calling system
NAR	North American route	SID	standard instrument departure
NASA	National Aeronautics and Space Administration (USA)	SIGMET.....	significant meteorological information
NAT	North Atlantic	SM	statute mile
NATO	North Atlantic Treaty Organization	SNR	signal-to-noise ratio
NAVAID	navigation aid	SPECI.....	aerodrome special meteorological report
NCA	Northern Control Area	SPEC VIS	specified takeoff minimum visibility
NDA	Northern Domestic Airspace	SSALR.....	simplified short approach light system with runway alignment indicator lights
NDB	non-directional beacon	SSB	single sideband
NM	nautical mile	SSR	secondary surveillance radar
NO PT	no procedure turn	STAR	standard terminal arrival
NORDO	no radio	STOL aircraft.....	short takeoff and landing aircraft
NWS	North Warning System	SVFR	special VFR flight
OAC	oceanic area control centre	T	true
OAT	outside air temperature	TA	traffic advisory
OBST	obstacle	TAA.....	terminal arrival area
O/C	observer-communicator	TACAN.....	tactical air navigation aid
OCA	oceanic control area	TAS	true airspeed
OCL	obstacle clearance limit	TC	Transport Canada
ODALS	omnidirectional approach lighting system	TCA	terminal control area
OKTA	one-eighth	TCAS	traffic alert and collision avoidance system
OM	outer marker	TCH	threshold crossing height
OTS	organized track system	TCU	terminal control unit
OTT	over-the-top	TDZ	touchdown zone
PAC	Pacific	TDZE	touchdown zone elevation
PAL	peripheral station	TDZL	touchdown zone lighting
PAPI.....	precision approach path indicator	TLOF	touchdown and lift-off area
PAR	precision approach radar	TMI	track message identification
PAS	private advisory station	TODA	take-off distance available
PATWAS	pilots' automatic telephone weather answering service	TORA	take-off run available
PCN	pavement classification number (ICAO)	TP	Transport Canada publication
PIREP	pilot weather report	TRA	tower radar area
PLR	pavement load rating	TRP	tower radar plan
PPR	prior permission required	TSB	Transportation Safety Board of Canada
PRM.....	preferred routes messages	TSO	Technical Standard Order
PSI	pounds per square inch	TWR	control tower
PSR	primary surveillance radar	UHF	ultrahigh frequency
PT	procedure turn	UNICOM.....	universal communications
RA	resolution advisory	USB	upper sideband
RAAS	remote aerodrome advisory service	UTC	Coordinated Universal Time
RAIM	receiver autonomous integrity monitoring	VAS	vehicle advisory service
RCMP	Royal Canadian Mounted Police	VASIS	visual approach slope indicator system
RCO	remote communications outlet	VCOA	visual climb over the airport
RILS	runway identification lights	VCS	vehicle control service
RMI	radio magnetic indicator	VDF service.....	VHF direction finding service
RNAV	area navigation	VFR	visual flight rules
RNPC.....	required navigation performance capability	VHF	very high frequency
RONLY	receiver only	VLF	very low frequency
RSC	runway surface condition	VMC	visual meteorological conditions
RTF	radiotelephony frequency	VNAP	vertical noise abatement procedure
		VNC.....	VFR navigation chart
		VOLMET.....	in-flight meteorological information

VOR..... VHF omnidirectional range
 VORTAC..... combination of VOR and TACAN
 VTA..... VFR terminal area chart
 VTOL aircraft.....vertical takeoff and landing aircraft
 W west
 WMO..... World Meteorological Organization
 WP waypoint
 WS wind shear
 zulu (Z)..... Coordinated Universal Time

NOTES 1: The Supplements contain additional abbreviations applicable to aeronautical charts and publications.
 2: Abbreviations typical of meteorology are contained in MET 3.6.

5.3 LEGISLATION INDEX

This index provides a cross-reference between the CARs and corresponding TC AIM pages where relevant information can be found. Some administrative or enabling legislation has been omitted where it has been determined that knowledge of the rule is not required for aircraft operations.

The CARs section numbers contained throughout the text are those of the *Consolidated Regulations of Canada (CRC)*, Chapter 2, as contained in the CARs.

<i>Canadian Aviation Regulations</i>		
CARs Subpart No.	CAR Name	TC AIM Paragraph No.
Part I	General Provisions	LRA 7.5
103	Administration and Compliance	LRA 6.3, 6.4
Part II	Aircraft Identification and Registration and Operation of a Leased Aircraft by a Non-registered Owner	LRA 4.1, 4.6, 7.5
201	Identification of Aircraft and Other Aeronautical Products	LRA 4.2
202	Aircraft Marking and Registration	LRA 4.3, 4.7, 5.7.2
Part III	Aerodromes, Airports and Heliports	LRA 7.5
301	Aerodromes	AGA 2.1, 7.3
302	Airports	AGA 2.3.6
Part IV	Personnel Licensing and Training	LRA 7.5
403	Aircraft Maintenance Engineer Licences and Ratings	LRA 5.4.2
406	Flight Training Units	LRA 5.6.1
421	Flight Crew Permits, Licences and Ratings	LRA 1.1, 1.6, 1.12
424	Medical Requirements	LRA 1.1, 1.9, 2.2
Part V	Airworthiness	LRA 7.5
501	Annual Airworthiness Information Report	LRA 5.5
507	Flight Authority and Certificate of Noise Compliance	LRA 5.1, 5.3.1, 5.3.3

<i>Canadian Aviation Regulations</i>		
521	Approval of the Type Design or a Change to the Type Design of an Aeronautical Product	LRA 5.2.2, 5.6.1
521 Division IX	Service Difficulty Reporting	LRA 5.6.4
521 Division X	Airworthiness Directives	LRA 5.7.1
571	Aircraft Maintenance Requirements	LRA 5.4.1, 5.6.1
Part VI	General Operating and Flight Rules	RAC 3.1, LRA 7.5
601	Airspace	RAC 1.10, 2.8, 2.8.6, 2.9.2
602	Operating and Flight Rules	COM 5.2, COM Annex A 1.0, COM Annex B 2.0, RAC 1.7, 1.9, 1.10, 1.11, 2.3.1, 2.5.2, 2.7.3, 2.7.4, 2.10, 2.11, 2.12, 2.13, 3.1, 3.2, 3.6.1, 3.6.2, 3.7.1, 3.7.2, 3.9, 3.12, 3.12.1, 3.13, 3.14, 4.1, 4.1.2, 4.3, 4.4.8, 4.5.2, 4.5.4, 4.5.7, 5.4, 5.5, 6.1, 6.2, 8.1, 8.4, 8.5, 8.6, 9.7.3, 9.13, 9.19.1, 9.20.1, 9.20.2, 11.2, 12.8, 12.14, 12.15.6, RAC Annex 2.0, FAL 2.3.2, AIR 2.11.2, 2.11.3, 2.14, 2.14.1, 4.4.2, 4.8
603	Special Flight Operations	RAC 2.5.2, AIR 4.8
604	Private Operator Passenger Transportation	COM Annex B 3.1, RAC 9.19, LRA 2.6.1
605	Aircraft Requirements	SAR 3.1, 3.9, LRA 2.3.1, 2.4.1, 2.6.1, 2.6.3, 2.7.1, 2.7.3
625	Aircraft Equipment and Maintenance Standard	LRA 5.4.1, 5.6.1, 5.7.1
Part VII	Commercial Air Services	RAC 9.19, LRA 2.6.1, 5.5, AIR 2.14.1
703	Air Taxi Operations	AIR 4.4.2, COM Annex B 2.0
723	Air Taxi—Aeroplanes	COM Annex B 3.1
704	Commuter Operations	AIR 4.4.2, COM Annex B 2.0
724	Commuter Operations—Aeroplanes	COM Annex B 2.0
705	Airline Operations	AIR 4.4.2, COM Annex B 2.0
725	Airline Operations—Aeroplanes	COM Annex B 3.1
706	Aircraft Maintenance Requirements for Air Operators	LRA 5.6.1
Part VIII	Air Navigation Services	LRA 5.6.4

6.0 CIVIL AVIATION CONTINGENCY OPERATIONS (CACO)

6.1 INTRODUCTION

The Civil Aviation Contingency Operations (CACO) Division is part of the Transport Canada Civil Aviation, National Operations Branch. It is the focal point for providing services in the areas of contingency planning, exercises and operational response in support of the Civil Aviation emergency response mandate. In addition, it participates in or provides support to the aviation-related activities of NATO, the North American Aerospace Defence Command (NORAD), ICAO, the FAA and NASA (shuttle-launching).

6.2 HEADQUARTERS OPERATIONS

CACO manages the national Aviation Operations Centre (AOC). The AOC monitors the national civil air transportation system (NCATS) 24 hours a day, and responds to NCATS emergencies that require the attention or co-ordination of concerned functional branches, including regional offices and other departments or agencies, as per contingency plans.

6.3 CIVIL AVIATION ACCIDENT, OCCURRENCE, OR INCIDENT REPORTING

The AOC is the initial contact point for all aviation-related occurrences. It receives reports on accidents, occurrences, and any incidents that occur within the NCATS from various sources, including NAV CANADA, airport authorities, Public Safety Canada (PS), law enforcement agencies, other government departments, foreign governments, and the general public. These reports are continuously monitored and then distributed to the appropriate functional areas of Transport Canada Civil Aviation for review, investigation (if necessary), and final inclusion in the CADORS.

Reports requiring regional, modal, multi-modal, inter-departmental, or an outside agency's attention are immediately forwarded to that agency for further action.

To report an aircraft accident, occurrence, or incident, individuals can contact the AOC 24 hours a day by calling 1-877-992-6853 (toll-free) or 613-992-6853; sending a fax to 1-866-993-7768 (toll-free) or 613-993-7768; or via the Web site, at http://wwwapps.tc.gc.ca/saf-sec-sur/2/IR-RI/av_i_r.aspx?lang=eng.

For information on CACO, visit our Web site, at <http://www.tc.gc.ca/eng/civilaviation/opssvs/nationalops-caco-menu.htm>.

AGA – AERODROMES

1.0 GENERAL INFORMATION

1.1 GENERAL

All flights into, from or over the territory of Canada and landings in such territory shall be carried out in accordance with the regulations of Canada regarding civil aviation. Aircraft landing in or departing from the territory of Canada must first land at an aerodrome at which Customs control facilities have been provided. (See CFS for complete list.)

The privileges extended are subject to each flight having been properly authorized and to whatever restrictions the Government of Canada may, from time to time, or in specific cases, deem to be warranted.

1.1.1 Aerodrome Authority

Transport Canada is responsible for the surveillance of all certified civil aerodromes in Canada. The addresses can be found in GEN 1.1.2.

1.1.2 ICAO Documents

International Standards and Recommended Practices, Aerodromes, ANNEX 14, Volumes I and II.

1.1.3 Differences with ICAO Standards, Recommended Practices and Procedures

Differences between Canadian regulations and practices and ICAO standards, recommended practices and procedures will be published at a future date.

1.1.4 Canadian Runway Friction Index

Many airports throughout Canada are equipped with mechanical and electronic decelerometers which are used to obtain an average of the runway friction measurement. The average decelerometer reading of each runway is reported as the Canadian Runway Friction Index (CRFI). Experience has shown that results obtained from the various types of decelerometers on water and slush are not accurate, and the CRFI will not be available when these conditions are present.

Aerodromes equipped with runway friction decelerometer capability are listed in CFS under “Runway Data”.

Operational data relating to the reported average CRFI and the methods to be used when applying the factors to aircraft performance are presented in AIR 1.6.

1.1.5 Contaminated Runway Operations

Canadian Civil Aerodromes

At Canadian Aerodromes where snow removal and ice control operations are conducted, assessment and mitigation procedures, are carried out to the extent that is practicable in order to provide movement surfaces that will permit safe operational use.

Pilots who are confronted with conditions produced by the changing Canadian climate must be familiar with and anticipate the overall effect of contaminated runways on aircraft handling characteristics in order to take any corrective actions considered necessary for flight safety.

In general terms, whenever a contaminant such as water, snow or ice is introduced onto the runway surface, the effective coefficient of friction between the aircraft tire and runway is reduced. However, the accelerate/stop distance, landing distance and crosswind limitations contained in aircraft flight manuals are demonstrated in accordance with specified performance criteria on bare and dry runways during the aircraft certification flight test program, and are thus valid only when the runway is bare and dry.

As a result, the stop portion of the accelerate/stop distance will increase, the landing distance will increase and a crosswind will present directional control difficulties.

It is therefore expected that pilots will take all necessary action, including the application of any appropriate adjustment factor to calculate stopping distances for their aircraft as may be required based on the Runway Surface Condition and CRFI information.

Department of National Defence Aerodromes

Snow removal and ice control policy and procedures at Canadian military aerodromes are similar to those of Canadian Civil Aerodromes; however, the military aerodrome operator may not use the same type of decelerometer to obtain the average runway friction index.

1.1.6 Bird Hazard

Most major airports in Canada have a plan to identify and control the hazards birds present to flight operations. This situation generally is a problem during the spring and autumn migrations; however, some airports are continuously subjected to bird hazard. Pilots should monitor ATIS during the migratory season for information concerning this hazard.

For more information on bird hazard, migratory birds and bird strike reporting, see RAC 1.15.

1.2 INTERNATIONAL AIRPORTS

Some airports are designated “International Airport” by Transport Canada to support international commercial air transport and are listed as such in the *ICAO Air Navigation Plan - North Atlantic, North American, and Pacific Regions* (ICAO Doc 8755/13). (See FAL 2.2.2 for information on International Commercial Flights.)

1.2.1 ICAO Definitions

International Scheduled Air Transport, Regular Use (RS): An aerodrome which may be listed in the flight plan as an aerodrome of intended landing.

International Scheduled Air Transport, Alternate Use (AS): An aerodrome specified in the flight plan to which a flight may proceed when it becomes inadvisable to land at the aerodrome of intended landing.

International General Aviation, Regular Use (RG): All aircraft other than those operated on an international air service.

NOTE: Any of the listed regular aerodromes may be used as a regular or alternate aerodrome.

1.3 AERODROME DIRECTORY

Complete general data on aerodromes is listed in CFS. ICAO Type A Charts are available from Aeronautical Information Service (see MAP 3.6).

1.4 AERONAUTICAL GROUND LIGHTS

Aeronautical ground lights are found in CFS under the aerodrome they serve or on VFR navigational charts.

Rules for operating an aerodrome are provided in Part III of the *Canadian Aviation Regulations* (CARs) under Subsection 301. The focus is to define the minimum safety standards that must be offered as well as making provision for inspection by the Minister. The operators of aerodromes are encouraged, in the interest of aviation safety, efficiency and convenience to improve their aerodromes beyond the basic regulatory requirements using, as guidelines, the standards and recommended practices applicable for the certification of aerodromes as airports. The users of aerodromes are, however, reminded that the improvement of aerodrome physical characteristics, visual aids, lighting and markings beyond the basic regulatory requirements for aerodromes is a matter of individual aerodrome operator initiative. Such improvements do not require regulatory compliance, nor are those improvements inspected or certified in accordance with the standards and recommended practices applicable for the certification of aerodromes as airports.

Subsection 301 also puts into regulation the “Registration” process, which is used to publish and maintain information on an aerodrome in the *Canada Flight Supplement* (CFS) or the *Canada Water Aerodrome Supplement* (WAS). This specifies that an aerodrome operator can expect:

- (a) their aerodrome will be registered in the appropriate publication when the operator provides the necessary information respecting location, markings, lighting, use and operation of the aerodrome;
- (b) their aerodrome will not be registered in the appropriate publication if the operator of the aerodrome does not meet the aerodrome regulatory requirements for markers and markings, warning notices, wind direction indicator and lighting;
- (c) to assume responsibility to immediately notify the Minister of any changes in the aerodrome’s published information regarding location, markings, lighting, use or operation of the aerodrome; and
- (d) their aerodrome will be classed as a registered aerodrome when it is published in the CFS or WAS.

NOTE: No aerodrome operator is obliged by these regulations to have information published in the CFS or WAS and the Minister may choose not to publish information for a site that is considered to be hazardous to aviation safety.

In addition to the initial application inspection, registered aerodromes are inspected on a required basis to verify compliance with CARs and the accuracy of information published in the CFS and WAS. Such information, however, is only published for the convenience of the pilot and should be confirmed through contact with the aerodrome operator before using a site.

2.0 AERODROMES AND AIRPORTS

2.1 GENERAL

An aerodrome is defined by the Aeronautics Act as:

Any area of land, water (including the frozen surface thereof) or other supporting surface used, designed, prepared, equipped or set apart for use either in whole or in part for the arrival, departure, movement or servicing of aircraft and includes any buildings, installations and equipment situated thereon or associated therewith.

This has a very broad application for Canada where there are no general restrictions preventing landings or takeoffs. There are defined exceptions, but, for the most part, all of Canada can be an aerodrome.

Besides the “Aerodrome” and “Registered Aerodrome” terminology, there is also the term “Airport.” This is an aerodrome for which a certificate has been issued under Subsection 302 of CARs. The objective is to protect those that do not have the knowledge or ability to protect themselves—the fare paying public and the resident in the vicinity of an airport that could be affected by unsafe operations. This is done by ensuring the site is inspected periodically for compliance with Transport Canada Standards for obstruction surfaces, physical characteristics, marking and lighting, which have been recorded in an Airport Operations Manual, and Airside Operating Procedures. The current status is to be advertised to all interested aircraft operators through the CFS, *Canada Air Pilot* (CAP), NOTAM and voice advisory as applicable.

2.2 USE OF AERODROMES AND AIRPORTS

Public Use: An aerodrome or airport listed in the CFS or WAS that does not require prior permission of the aerodrome or airport operator for aircraft operations is called a public-use aerodrome or airport.

Private Use: An aerodrome or airport can be listed in the CFS or WAS, but be limited in its use. This can include:

- (a) *Prior Permission Required (PPR):* The aerodrome operator’s permission is required prior to use. All military aerodromes require PPR for Civilian aircraft.
- (b) *Prior Notice Required (PNR):* The aerodrome operator owner or operator is to be notified prior to use in order that current information on the aerodrome may be provided.

NOTES 1: Pilots and aerodrome operators are reminded that aerodrome or airport trespass restrictions are not applicable to aircraft in distress.

- 2: Pilots intending to use a non-certified aerodrome are advised to obtain current information from the aerodrome operator concerning operating conditions prior to using that aerodrome for aircraft operations.

2.3 AIRPORT CERTIFICATION

2.3.1 General

Transport Canada has the responsibility for the development and operation of a safe national air transportation system. Therefore, airports supporting passenger-carrying commercial operations must meet accepted safety standards. An airport certificate testifies that an aerodrome meets such safety standards. Where exemptions from airport certification safety standards are required, studies will be undertaken to devise offsetting procedures, which will provide equivalent levels of safety.

2.3.2 Applicability of Airport Certification

The requirement for airport certification applies to:

- (a) any aerodrome that is located within the built-up area of a city or town;
- (b) any land aerodrome that is used by an air operator for the purpose of a scheduled service for the transport of passengers; and
- (c) any other aerodrome, where the Minister is of the opinion that it is in the public interest for that aerodrome to meet the requirements necessary for the issuance of an airport certificate.

Exempt are:

- (a) military aerodromes; and
- (b) aerodromes for which the Minister has written an exemption, and an equivalent level of safety is defined.

2.3.3 Transport Canada Responsibilities

The responsibilities of Transport Canada include:

- (a) developing safety standards, policies and criteria for:
 - (i) airfield physical characteristics, including runway and taxiway dimensions, and separations,
 - (ii) marking and lighting of manoeuvring surfaces and obstacles, and
 - (iii) obstacle limitation surfaces in the vicinity of airports;
- (b) providing assistance to airport operators in drafting Airport Operations Manuals (AOM);
- (c) conducting aeronautical studies where exemptions from airport certification safety standards are required;
- (d) certifying airports and inspect against the requirements and conditions of the AOM; and
- (e) verifying, amending and relaying pertinent airport information to be identified in the appropriate aeronautical information services (AIS) publications.

2.3.4 Operator Responsibilities

The aerodrome or airport operator’s responsibilities include:

- (a) completing and distributing an approved AOM;
- (b) maintaining an airport in accordance with the requirements specified in the AOM;

- (c) detailing the airport general operating procedures, including the following:
 - (i) hours of operation,
 - (ii) apron management and apron safety plans,
 - (iii) airside access and traffic control procedures,
 - (iv) snow and ice removal and grass cutting services,
 - (v) airport emergency services, such as Emergency Response Service (ERS) and medical services,
 - (vi) bird and animal hazard procedures,
 - (vii) airport safety programs, including Foreign Object Damage control,
 - (viii) airport security programs,
 - (ix) the issuance of NOTAM; and
- (d) advising Transport Canada and aircraft operators whenever services or facilities fall below requirements prescribed in the AOM.

2.3.5 Airport Certification Process

Airport certification is a process whereby Transport Canada certifies that an aerodrome meets airport certification safety standards and that aerodrome data, as provided by the owner or operator and confirmed by Transport Canada inspectors, is correct and published in the appropriate aeronautical information publications. When these requirements are met, an airport certificate is issued. The airport certificate documentation includes:

- (a) the airport certificate, which certifies that the airport meets required standards; and
- (b) the AOM, which details the airport specifications, facilities and services, and specifies the responsibilities of the operator for the maintenance of airport certification standards. The AOM is a reference for airport operations and inspections, which ensures that deviations from airport certification safety standards and the resulting conditions of airport certification are approved.

2.3.6 Regulatory References for Airport and Heliport Certification

The regulatory authority for airport certification is Subpart 302 of the CARs. The regulatory authority for heliport certification is Subpart 305 of the CARs. Standards for airport certification and the associated process are contained in the *Aerodrome Standards and Recommended Practices* (TP 312E), while standards for heliport certification and the associated process are contained in CARs Standard 325—*Heliports and the Heliport and Helideck Standards and Recommended Practices* (TP 2586E). Depending on the date on which the heliport certificate was issued, heliport operators will have to comply with either CARs Standard 325 or TP 2586E.

2.4 AIRPORT CERTIFICATE

2.4.1 Issue

An airport certificate will be issued when an inspection confirms that all requirements for airport certification have been met, including the following:

- (a) where an exemption from airport certification safety standards exists, measures have been implemented to provide for an equivalent level of safety; and
- (b) the AOM has been approved by the Regional Director, Civil Aviation.

2.4.2 Airport Certificate Validity and Amendments

The airport certificate is a legal aviation document that remains valid as long as the airport is operated in accordance with the AOM. Periodic inspections are conducted to verify continued conformity to airport certification safety standards and conditions specified in the AOM.

Transport Canada may make amendments to the conditions of issue of an airport certificate where:

- (a) an approved deviation from airport certification safety standards and a change in the conditions of airport certification are required;
- (b) there is a change in the use or operations of the airport;
- (c) there is a change in the boundaries of the airport; and
- (d) it is requested by the holder of the airport certificate.

3.0 RUNWAY CHARACTERISTICS

3.1 RUNWAY LENGTH AND WIDTH

Runways are generally dimensioned to accommodate the aircraft considered to be the “critical aircraft” that is anticipated to utilize the runways most frequently. The “critical aircraft” is defined as being the aircraft type which the airport is intended to serve and which requires the greatest runway length. To identify the “critical aircraft”, flight manual performance data of a variety of aircraft are examined. Once the “critical aircraft” has been determined, the longest distance determined from analyzing both take-off and landing performance is used as the basis for runway dimensions. Generally, the runway width is increased to a maximum of 60 m as a function of length.

3.2 GRADED AREA

Each runway is bounded on the sides and ends by a prepared “graded” area. This graded area is provided to prevent catastrophic damage to aircraft leaving the runway sides and to protect aircraft that overfly the runway at very low altitudes during a balked approach for landing. The graded area at the end of the runway is not considered a normal stopway for accelerate-to-stop calculations.

3.3 DISPLACED RUNWAY THRESHOLD

Occasionally, natural and human-made obstacles penetrate the obstacle limitation surfaces of the take-off and approach paths to runways.

To ensure that a safe clearance from these obstacles is maintained, it is necessary to displace the runway thresholds. In the case of runways for which instrument approach procedures are published in the CAP, the usable runway distances for landings and takeoffs are specified as declared distances. The displacements are also depicted on the aerodrome or airport diagram in both the CAP and the CFS. For other runways not having published CAP approaches, the requisite data is given in the CFS. Where a threshold is displaced, it is marked as shown in AGA 5.4.1.

When the portion of the runway before the displaced threshold is marked with displaced threshold arrows (see AGA 5.4.1), it is permissible to use that portion of the runway for taxiing, for takeoff and for the landing roll-out from the opposite direction. In addition, this displaced portion of the runway may be used for landing; however, it is the pilot’s responsibility to ensure that the descent path can be safely adjusted to clear all obstacles. When taking off from the end opposite to the displaced threshold, pilots should recognize the fact that there are obstacles present that penetrated above the approach slope to the physical end of the runway, which resulted in the threshold being displaced.

When a section of a runway is closed, either temporarily because of construction or permanently because the full length is no longer required, the closed portion of the runway is unavailable for the surface movement of aircraft for taxiing, take-off or landing purposes and is marked with an “X”, indicating that the area is not suitable for aircraft use. A lighted “X” may also be used to mark a temporarily closed runway.



The closed portion of the runway may be shown on the aerodrome or airport diagram in the CFS and the CAP for identification purposes; however, declared distances will only include runway length starting at the new threshold position.

3.4 TURNAROUND BAY

Some runways have thresholds not served directly by taxiways. In such cases, there may be a widened area which can be used to facilitate turnaround. Pilots are cautioned that these bays do not give sufficient clearance from the runway edge to allow their use for holding while other aircraft use the runway.

3.5 PRE-THRESHOLD AREA

A paved, non load-bearing surface that precedes a runway threshold is marked over the entire length with yellow chevrons, as shown in AGA 5.4.2, when its length exceeds 60 m.

3.6 STOPWAY

A stopway is a rectangular area on the ground at the end of the runway, in the direction of takeoff, prepared as a suitable area in which an aeroplane can be stopped in the case of an abandoned takeoff. It is marked over the entire length with yellow chevrons as shown in AGA 5.4.2 (when its length exceeds 60 m) and is lighted with red edge and end lights in the take-off direction. Its length is included in the ASDA declared for the runway.

3.7 CLEARWAY

A clearway is a rectangular area above the ground or water selected as a suitable area over which an aeroplane may make a portion of its initial climb.

3.8 DECLARED DISTANCES

The CAP provides declared distance information which is defined as follows:

- (a) *Take-off Run Available (TORA)*: The length of runway declared available and suitable for the ground run of an aeroplane taking off.
 - (b) *Takeoff Distance Available (TODA)*: The length of the takeoff run available plus the length of the clearway, if provided.
- NOTE: Maximum clearway length allowed is 300 m. The clearway length allowed must lie within the aerodrome or airport boundary.**
- (c) *Accelerate Stop Distance Available (ASDA)*: The length of the takeoff run available plus the length of the stopway, if provided.
 - (d) *Landing Distance Available (LDA)*: The length of runway which is declared available and suitable for the ground run of an aeroplane landing.

3.9 RAPID-EXIT TAXIWAYS

To reduce the aircraft runway occupancy time, some aerodromes or airports provide rapid-exit taxiways which are angled at approximately 30 degrees to the runway.

3.10 RUNWAY AND TAXIWAY BEARING STRENGTH

The bearing strength of some aerodrome or airport pavement surfaces (runways, taxiways and aprons) to withstand continuous use by aircraft of specific weights and tire pressures has been assessed at specific locations. The TC Pavement Load Rating (PLR) and ICAO Pavement Classification Number (PCN) define the weight limits at or below which the aircraft may operate on pavements without prior approval of the aerodrome or airport authority. The tire pressure and Aircraft Load Rating (ALR)/Aircraft Classification Number (ACN) must be equal to or less than the PLR/PCN figures published for each aerodrome or airport. Aircraft exceeding published load restrictions may be permitted limited operations following an engineering evaluation by the airport operator. Requests to permit such operations should be forwarded to the airport operator and include the type of aircraft, operating weight and tire pressure, frequency of proposed operation and pavement areas required at the aerodrome or airport.

3.10.1 Pavement Load Rating Charts

Operators requiring information respecting aircraft weight limitations in effect at an aerodrome or airport can contact the airport operator.

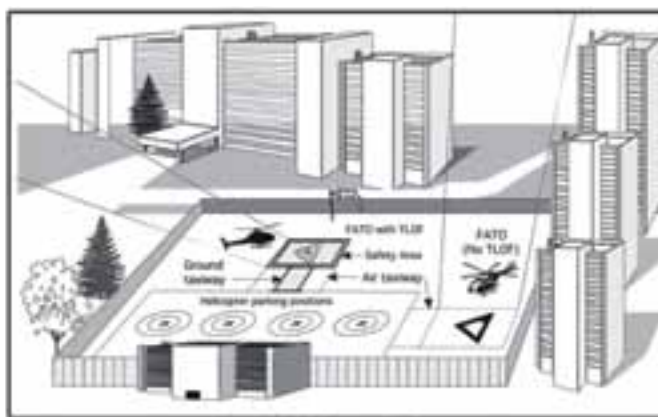
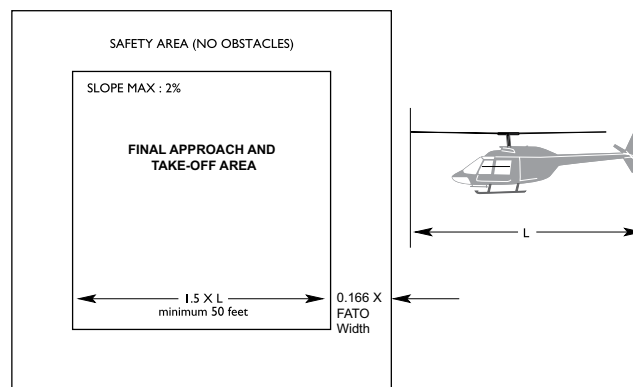

Illustration of a heliport general layout

3.11 HELIPORTS

Because of the unique operational characteristics of helicopters, heliport physical characteristics are significantly different from the physical characteristics of aerodromes. For instance, there is no requirement for a runway at a heliport. In addition, the heliport FATO size is 1.5 times larger than the longest helicopter for which the heliport is certified. A safety area surrounds the FATO, which is to be kept free of obstacles other than visual aids.

FINAL APPROACH AND TAKE-OFF AREA / SAFETY AREA



3.11.1 FATO

Obstacle-free arrival and departure paths to and from a FATO are always required. In some cases, a FATO can be offset from the intended landing area. In this case, helicopter parking positions are established on an apron area and pilots will hover taxi to transition between the FATO and the parking position.

3.11.2 Heliport Classification

Non-instrument heliports have three classifications: H1, H2 and H3. H1 heliports have no available emergency landing areas within 625 m from the FATO and are restricted for use by multi-engined helicopters capable of remaining 4.5 m above all obstacles within the defined approach/departure pathways when operating with one engine inoperative and in accordance with their aircraft flight manual (AFM).

H2 heliports have available emergency landing areas within 625 m from the FATO; however, due to high obstacles within

the approach/departure pathways, the associated approach slopes are higher, requiring the use of multi-engined helicopters. H3 heliports have available emergency landing areas within 625 m from the FATO and no obstacles that penetrate the obstacle limitation surfaces, and as such, may be used by single- or multi-engined helicopters. Heliport classifications are specified in the CFS.

3.11.3 Heliport Operational Limitations

All heliports have three operational limitations. The limitations for each specific heliport are listed in the CFS.

The *load bearing strength* shall be identified for each elevated or rooftop FATO or floating supporting structure. Surface-level heliports need not list a load bearing strength.

The *maximum helicopter overall length* shall be identified for each FATO. This is calculated as the width or diameter of each FATO, divided by 1.5. This number represents the largest size helicopter for which the FATO is certified.

The *heliport category* (instrument or non-instrument) and *classification*, as detailed in AGA 3.11.2, above, shall also be listed.

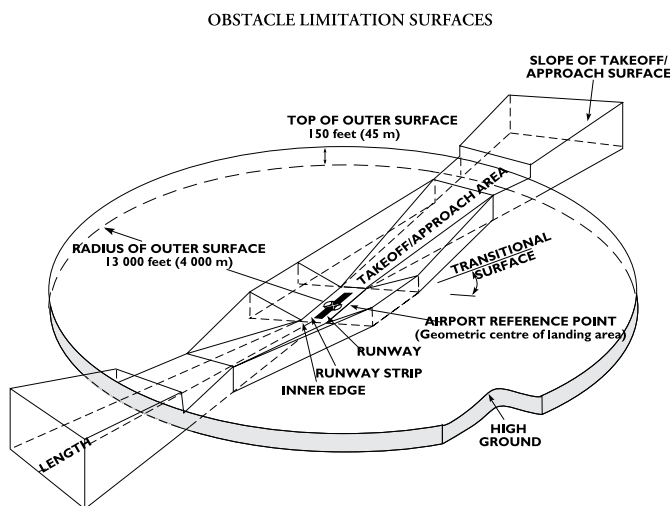

AGA

4.2.2 Heliports

Heliports are normally served by two approach and departure paths. In some instances, only one approach and departure path may be established and will have the additional requirement for a transition surface.

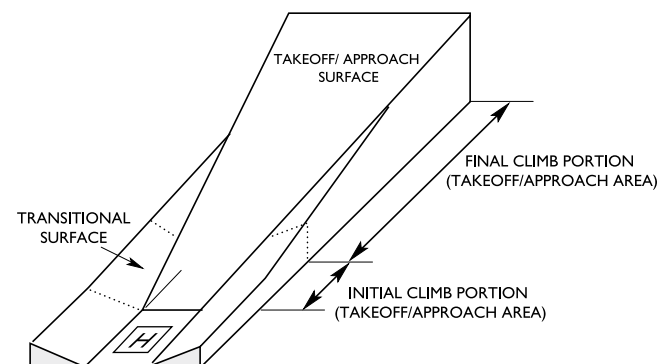

4.0 OBSTACLE RESTRICTIONS

4.1 GENERAL

The safe and efficient use of an aerodrome, airport or heliport can be seriously eroded by the presence of obstacles within or close to the take-off or approach areas. The airspace in the vicinity of takeoff or approach areas (to be maintained free from obstacles so as to facilitate the safe operation of aircraft) is defined for the purpose of either:

- (a) regulating aircraft operations where obstacles exist;
- (b) removing obstacles; or
- (c) preventing the creation of obstacles.

4.2 OBSTACLE LIMITATION SURFACES

4.2.1 General

An obstacle limitation surface establishes the limit to which objects may project into the airspace associated with an aerodrome and still ensure that aircraft operations at the aerodrome will be conducted safely. It includes a take-off/approach surface, a transitional surface and an outer surface.

4.3 AIRPORT ZONING REGULATIONS

4.3.1 General

An Airport Zoning Regulation is a regulation respecting a given airport pursuant to section 5.4(1) of the *Aeronautics Act* for the purposes of:

- (a) preventing lands adjacent to or in the vicinity of a TC airport or airport site from being used or developed in a manner that is, in the opinion of the Minister, incompatible with the operation of an airport;
- (b) preventing lands adjacent to or in the vicinity of an airport or airport site from being used or developed in a manner that is, in the opinion of the Minister, incompatible with the safe operation of an airport or aircraft; and

- (c) preventing lands adjacent to or in the vicinity of facilities used to provide services relating to aeronautics from being used or developed in a manner that would, in the opinion of the Minister, cause interference with signals or communications to and from aircraft or to and from those facilities.

NOTE: An Airport Zoning Regulation applies only to land *outside* the boundary of the airport protected by the *Airport Zoning Regulation*. Obstacles *within* an airport boundary must not penetrate an obstacle limitation surface for the runway(s) involved unless the obstacle is exempted as the result of an aeronautical study.

4.3.2 Airports Where Zoning Regulations Are in Effect

A list of airports where Airport Zoning Regulations are in effect is maintained in the Regional Aerodrome Safety office.

5.0 MARKERS, MARKING, SIGNS AND INDICATORS

5.1 AIRCRAFT TAKEOFF OR LANDING AREA BOUNDARY MARKERS

The take-off or landing area boundaries of aerodromes without prepared runways are indicated by conical- or gable-type markers (highway-type cone markers are acceptable) or by evergreen trees in winter. No boundary markers are required if the entire movement area is safe for aircraft operations. The markers are typically coloured international orange and white or solid international orange.

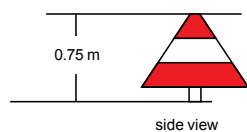
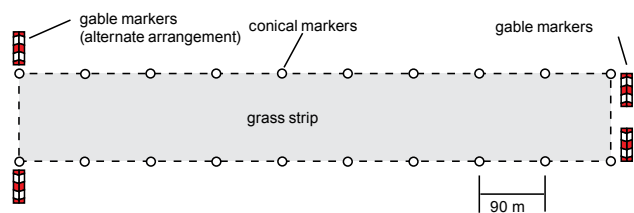

conical-type marker

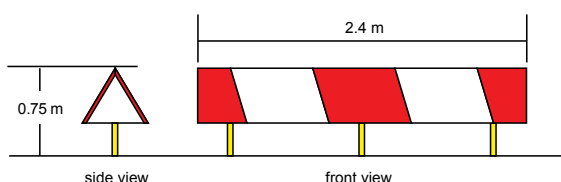

gable-type marker

Examples of conical and gable markers

5.2 AIR TAXIWAY EDGE MARKERS

The edges of the air taxiway route are indicated by markers 35 cm in height, and consist of three equal horizontal bands arranged vertically. The top and bottom bands are yellow and the middle one is green.

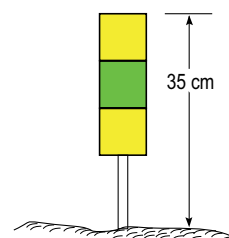

5.3 SEAPLANE DOCK MARKERS

Seaplane docks are marked to facilitate their identification. The dock is marked with an equilateral triangle measuring 2.4 m on each side. The dock to which this marker is affixed also has red/white side marking.

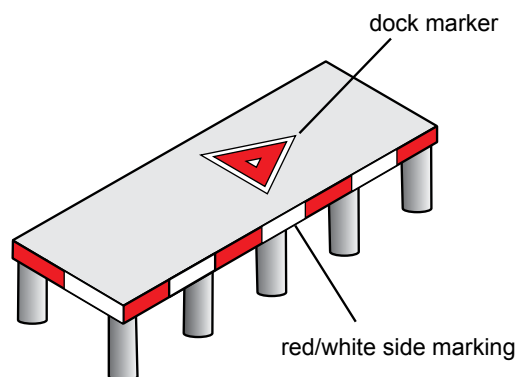
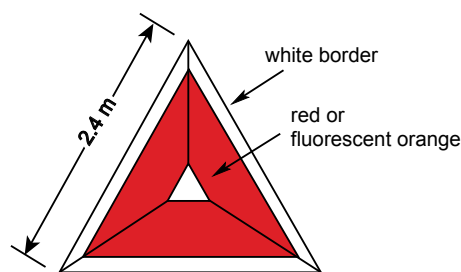

5.4 RUNWAY MARKINGS

Aeroplane runway markings vary depending on runway length and width, and are described in detail in Transport Canada publication, *Aerodrome Standards and Recommended Practices* (TP 312E). The colour of the markings is white. The number of pairs of touchdown zone markings depends on the LDA, as shown in the table below. Where operationally necessary, an additional pair of touchdown zone marking stripes may be provided on a Code 2 runway, 150 m beyond the beginning of the aiming point marking.

Landing Distance Available (LDA)	Pair(s) of stripes
less than 900 m	1
900 m up to but not including 1 200 m	2
1 200 m up to but not including 1 500 m	3
1 500 m up to but not including 2 400 m	4
2 400 m or more	6

The aiming point marking is provided at a distance from the threshold according to the table below. With application of aiming point marking, pairs of touchdown zone markings are omitted if intended for the same location or if they are to be placed within 50 m of an aiming point marking.

Landing Distance Available (LDA)	Distance, threshold to start of marking
less than 800 m	150 m
800 m up to but not including 1 200 m	250 m
1 200 m up to but not including 2 400 m	300 m
2 400 m or more	400 m

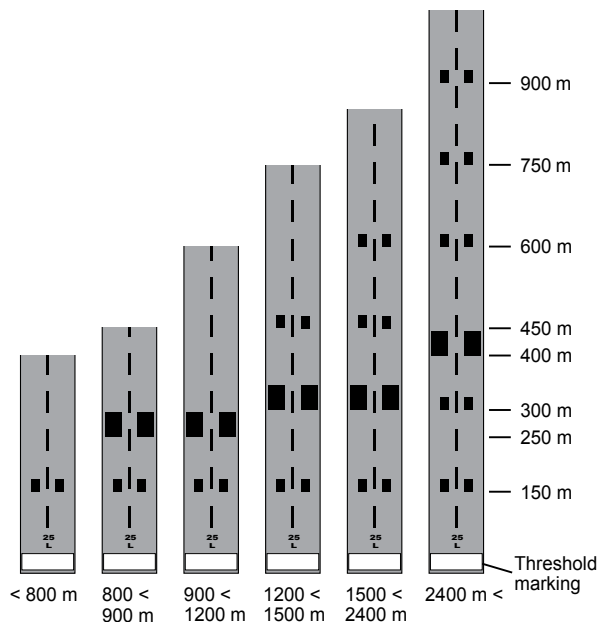

Examples of Runway Marking

5.4.1 Displaced Threshold Markings

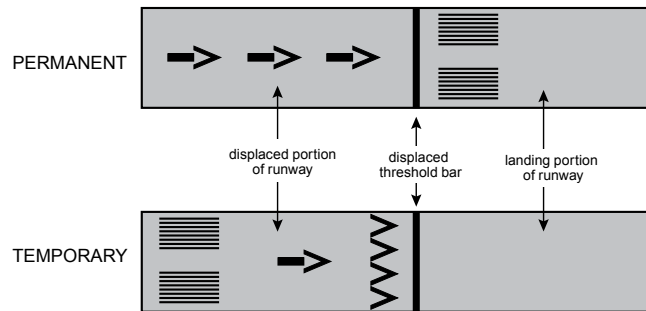

NOTE: When the threshold must be displaced for a relatively short period of time, painting a temporary threshold bar would be impractical. Flags, cones, or wing bar lights would be installed to indicate the position of the displaced threshold. A NOTAM or voice advisory warning of the temporary displacement will contain a description of the markers and the expected duration of the displacement in addition to the length of the closed portion and the remaining usable runway.

5.4.2 Stopways

The paved area preceding a runway threshold prepared, maintained and declared as a stopway is marked with yellow chevrons when its length exceeds 60 m. This area is not available for taxiing, the initial take-off roll or the landing rollout. The chevron markings may also be used on blast pads.

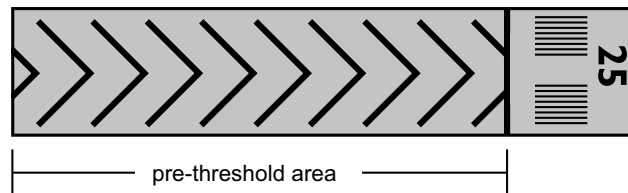

5.4.3 Taxiway Exit and Holding Markings

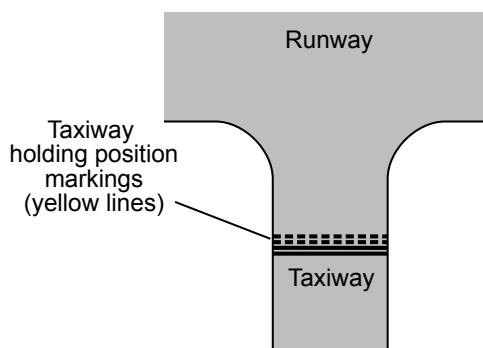

5.5 HELIPORTS

5.5.1 Heliport TLOF Marking

When the perimeter of the TLOF is not otherwise obvious, it will be marked by a continuous white line.

5.5.2 Safety Area Markers

The safety area that surrounds the FATO may be indicated by pyramidal, conical or other types of suitable markers or markings.

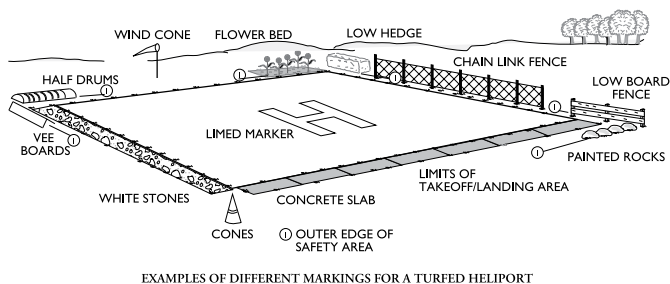

5.5.3 Heliport Identification Markings

Heliports are identified by a white capital letter “H” centred within the TLOF. Where it is necessary to enhance the visibility of the letter “H”, it may be centred within a dashed triangle. Hospital heliports are identified by a red capital letter “H” centred within a white cross.

The letter “H” will be oriented with magnetic north, except in the area of compass unreliability, where it will be true north.

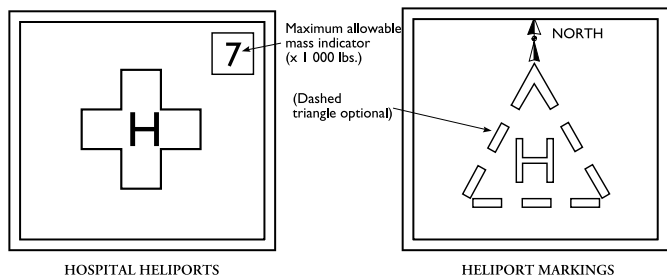

5.5.4 FATO Marking

Where practicable, the boundary of the FATO will be indicated by pyramidal, conical or other types of suitable markers. The markers shall be frangible and shall not exceed a height of 25 m. An aiming point marking will be provided and located in the centre of the FATO, where practicable. Where the direction of the helicopter parking position is not obvious, an indicator will show its direction.

5.5.5 Helicopter Parking Position Marking

Helicopter parking position markings consist of two concentric yellow circles. The diameter of the outer circle shall not be less than 1.2 times the overall length of the longest helicopter for which the helicopter parking position is certified. The diameter of the inner circle is one-third of the size of the outer circle. An “H” marking will be centred within the inner circle.

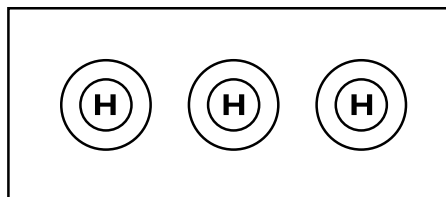

5.5.6 Approach and Take-Off Direction Indicator Markings

There may be heliports where, due to nearby obstacles or noise-sensitive areas, approach and take-off directions are designated. The direction of the approach and take-off paths is indicated by a double-headed arrow, showing their inbound and outbound directions. They are located beyond the edge of the safety area or on the aiming point marking.

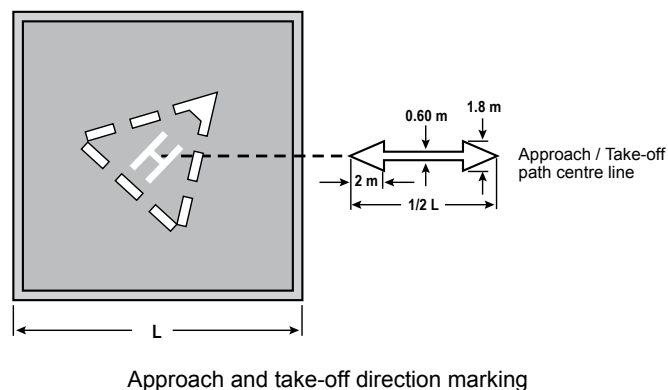

5.6 CLOSED MARKINGS

Runways, taxiways or portions thereof, and helicopter FATOs that are closed to aircraft operations are marked by white or yellow Xs, 6 m in length. Snow-covered areas may be marked by Xs formed by conspicuously coloured dye. When a runway, taxiway or helicopter FATO is permanently closed, all markers and markings except the X's are removed.

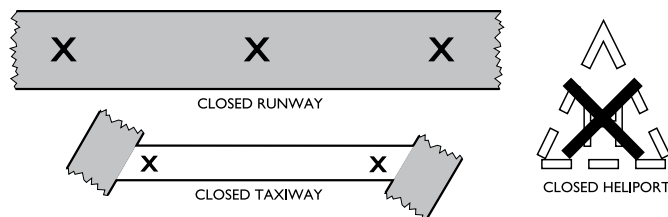

5.7 UNSERVICEABLE AREA MARKINGS

Unserviceable portions of the movement area other than runways and taxiways are delineated by markings such as marker boards, cones, or red flags and, where appropriate, a flag or suitable marker is placed near the centre of the unserviceable area. Red flags are used when the unserviceable portion of the movement area is sufficiently small for it to be by-passed by aircraft without affecting the safety of their operations.

5.8 AIRSIDE GUIDANCE SIGNS

5.8.1 General

The primary purpose of airside guidance signs is to provide direction and information to pilots of taxiing aircraft for the safe and expeditious movement of aircraft on the aprons, taxiways and runways.

Airside guidance signs are divided into two categories by using colours to differentiate between signs that provide guidance or information and signs that provide mandatory instructions.

5.8.2 Operational Guidance Signs

Operational guidance signs provide directions and information to pilots. The inscriptions incorporate arrows, numbers, letters or pictographs to convey instructions, or to identify specific areas.

- (a) *Location Sign:* A location sign has a yellow inscription on a black background and is used to identify the taxiway which the aircraft is on or is entering. A location sign never contains arrows.



Location sign

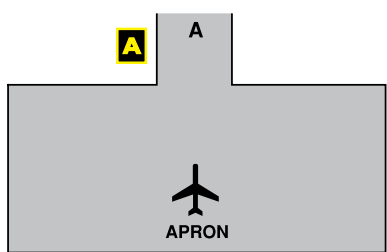

Apron to taxiway intersection

- (b) *Direction Sign:* A direction sign has a black inscription on a yellow background and is used to identify the intersecting taxiways toward which an aircraft is approaching. The sign is, whenever possible, positioned to the left-hand side of the taxiway and prior to the intersection. A direction sign will always contain arrows to indicate the approximate angle of intercept. Direction signs are normally used in combination with location signs to provide the pilot with position information. The location sign will be in the centre or datum position. In this configuration, all information on taxiways that require a right turn are to the right of the

location sign and all information on taxiways that require left turns are to the left of the location sign.



Direction

Location

Direction

The only exception to this rule is for a simple “T” or “+” intersection. In this case, the location sign and direction sign may be as depicted below.

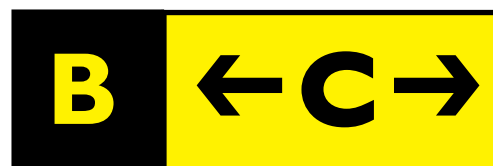

Location
(Left Side)

Direction

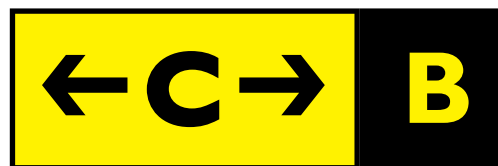

Direction

Location
(Right Side)

When a taxiway continues through the intersection and changes heading by more than 25° or changes its designation, a direction sign will indicate this fact.

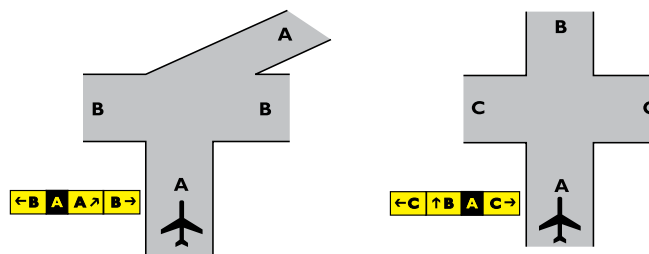

- (c) *Runway Exit Signs:* A runway exit sign has a black inscription on a yellow background and is used to identify a taxiway exiting a runway. The sign is positioned prior to the intersection on the same side of the runway as the exit. The sign will always contain an arrow and will indicate the approximate angle that the taxiway intersects the runway. When a taxiway crosses a runway, a sign will be positioned on both sides of the runway. Runway exit signs may be omitted in cases where aircraft do not normally use the taxiway to exit or in cases of one-way taxiways.

AGGA

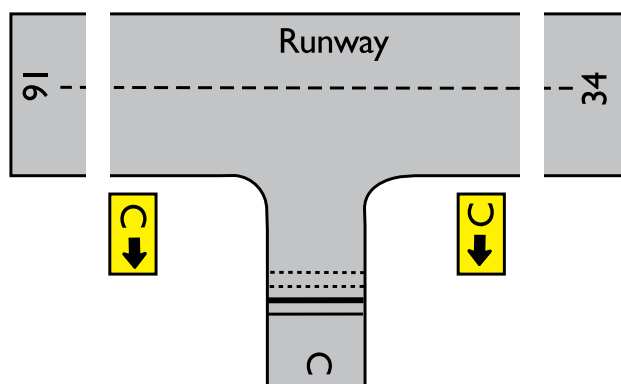

(d) *Destination Signs:* A destination sign has a black inscription on a yellow background and is used to provide general guidance to points on the airfield. These signs will always contain arrows. The use of destination signs will be kept to a minimum. Airports with a good direction sign layout will have little need for destination signs.



(e) *Other Guidance Signs:* Other guidance signs have a black inscription on a yellow background and include information such as stand identification, parking areas and frequency.



5.8.3 Mandatory Instruction Signs

Mandatory instruction signs are used to identify mandatory holding positions where pilots must receive further ATC clearance to proceed. At uncontrolled aerodromes, pilots are required to hold at points marked by these signs until they have ascertained that there is no air traffic conflict. Mandatory instruction signs have white letters, numbers or symbols against a red background.

(a) *Holding Position Sign:* A holding position sign is installed at all taxiway-to-runway intersections at certified aerodromes. A normal holding position sign is used for runways certified for VFR, IFR non-precision, and IFR precision CAT I operations. The sign, when installed at the runway end, shows the designator of the departure runway. Signs installed at locations other than the runway ends shall show the designator for both runways. A location sign is positioned in the outboard position beside the runway designator. A sign will be installed at least on the left side of the taxiway in line with the hold position markings. It is recommended that signs be installed on both sides of the taxiway.

In the following examples, “A” shows that an aircraft is located on Taxiway “A” at the threshold of Runway 25. The second example has the aircraft on Taxiway “B” at the intersection of Runway 25/07. The threshold of Runway 25 is to the left and Runway 07 to the right.



For airports located within the NDA, the same rules apply, except that the sign shows the exact true azimuth of the runway(s).

Northern Domestic Airspace



Location Runway Intersection

Holding position signs are also installed at runway-to-runway intersections when one runway is used regularly as a taxi route to access another runway or where simultaneous intersecting runway operations are authorized. In both cases, the signs are installed on each side of the runway.



(b) *Category II and Category III Holding Position Signs:* CAT II and CAT III holding position signs are installed to protect the ILS or MLS critical area during CAT II and CAT III operations. A sign is installed on each side of the taxiway in line with the CAT II/III hold position marking. The inscription will consist of the designator of the runway and the inscription CAT II, CAT III or CAT II/III as appropriate.



CAT II Hold Position

NOTE: Where only one holding position is necessary for all categories of operation, a CAT II/III sign is not installed. In all cases, the last sign before entering a runway will be the normal holding position sign.

(c) *No Entry Sign:* A no entry sign, as shown below, will be located on both sides of a taxiway into which entry is prohibited.

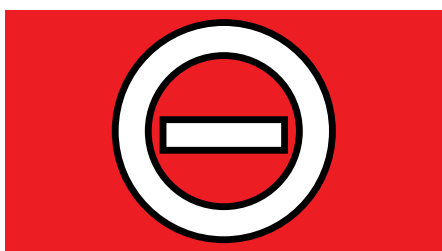

NO ENTRY

5.8.4 Illumination of Airside Guidance Signs

Airside guidance signs are illuminated at airports which are used at night or in low visibility. Signs, which are illuminated internally, may be of two types. In one case, the sign face is constructed from material, such as plexiglass, which permits the entire sign face to be illuminated. In the other case, the sign faces incorporate imbedded fibre optic bundles which illuminate the individual letters, numbers and arrows, not the face of the sign. At night or in low visibility, pilots approaching a fibre optic sign will see RED illuminated characters on mandatory instruction signs, YELLOW characters on a location sign, and WHITE characters on all other information signs.

NOTE: At the present time and for several years to come, signs not conforming to this convention will continue to be used. There are still airports which have signs with white characters on a green background. Pilots should be aware of the possibility of confusion, particularly when operating at unfamiliar airports.

5.9 WIND DIRECTION INDICATORS

At aerodromes that do not have prepared runways, the wind direction indicator is usually mounted on or near some conspicuous building or in the vicinity of the general aircraft parking area.

Runways greater than 1 200 m in length will have a wind direction indicator for each end of the runway. It will be located 150 m in from the runway end and 60 m outward, usually on the left side.

Runways 1 200 m in length and shorter will have a wind direction indicator centrally located so as to be visible from approaches and the aircraft parking area. Where only one runway exists, it will be located at the mid-point of the runway 60 m from the edge.

For night operations the wind direction indicator will be lighted.

NOTE: At aerodromes certified as airports, a dry Transport Canada standard Wind Direction Indicator will react to wind speed as follows:

WIND SPEED	WIND INDICATOR ANGLE
15 kt or above	Horizontal
10 kt	5° below horizontal
6 kt	30° below horizontal

At aerodromes not certified as airports, non-standard wind indicator systems may be in use which could react differently to wind speed.

6.0 OBSTRUCTION MARKING AND LIGHTING

6.1 GENERAL

Where it is likely that a building, structure or object, including an object of natural growth, is hazardous to aviation safety because of its height and location, the owner, or other person in possession or control of the building, structure or object, may be ordered to mark it and light it in accordance with the requirements stipulated in standard 621.19 to the *Canadian Aviation Regulations* (CARs), Standards Obstruction Markings.

Except in the vicinity of an airport where an airport zoning regulation has been enacted, Transport Canada has no authority to control the height or location of structures. However, all objects, regardless of their height, that have been assessed as constituting a hazard to air navigation require marking and/or lighting in accordance with the CARs and should be marked and/or lighted to meet the standards specified in CAR 621.19.

6.2 STANDARDS

The following obstructions should be marked and/or lighted in accordance with the standards specified in CAR 621.19:

- (a) any obstruction penetrating an airport obstacle limitation surface as specified in TP 312, *Aerodrome Standards and Recommended Practices*;
- (b) any obstruction greater than 90 m AGL within 3.7 km of the imaginary centreline of a recognized VFR route, including but not limited to a valley, a railroad, a transmission line, a pipeline, a river or a highway;
- (c) any permanent catenary wire crossing where any portion of the wires or supporting structures exceeds 90 m AGL;
- (d) any obstructions greater than 150 m AGL; and
- (e) any other obstruction to air navigation that is assessed as a likely hazard to aviation safety.

6.3 REQUIREMENTS FOR AN AERONAUTICAL EVALUATION

Because of the nature of obstructions, it is not possible to fully define all situations and circumstances. Thus, in certain cases, a Transport Canada aeronautical evaluation will be required to determine whether an obstruction to air navigation is a likely hazard to aviation safety or to specify alternative methods of complying with the obstacle marking and lighting standards while ensuring that the visibility requirement is met.

An aeronautical evaluation may be performed with respect to the following types of obstructions:

An aeronautical evaluation may be performed with respect to the following types of obstructions:

- (a) obstructions greater than 90 m AGL but not exceeding 150 m AGL;
- (b) catenary wire crossings, including temporary crossings, where the wires or supporting structures do not exceed 90 m AGL;
- (c) obstructions less than 90 m AGL; and
- (d) any other obstruction specified in CAR 621.19.

6.4 MARKING

Day marking of obstructions that are 150 m AGL in height or less, such as poles, chimneys, antennas, and cable tower support structures, may consist of alternate bands of aviation orange and white paint. A checkerboard pattern may be used for water tanks, as shown below. Where a structure is provided with medium or high-intensity white flashing strobe lighting systems that are operated during the day, paint marking of the structure may be omitted.

Figure 6.4.1: Storage Tank Marking

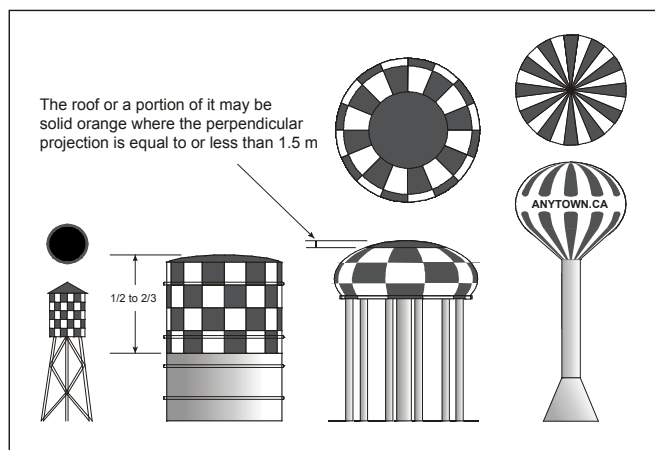

6.5 LIGHTING

Lighting is installed on obstructions in order to warn pilots of a potential collision.

The required intensity for this lighting is based upon an “acquisition distance” from which the pilot would recognize the lighting as identifying an obstruction, and be able to initiate evasive action to miss the obstruction by at least 600 m. For an aircraft operating at 165 kt, the acquisition distance is 1.90 km. For an aircraft operating between 165 and 250 kt, the acquisition distance is 2.38 km.

A variety of lighting systems are used on obstructions. The table below indicates the characteristics of light units according to their name or designation. Although these designations are similar to those of the FAA, the photometric characteristics (intensity distribution) are not necessarily the same.

- CL-810 steady-burning red obstruction light
 - Used primarily for night protection on smaller structures and for intermediate lighting on antennas of more than 45 m.
- CL-856 high-intensity flashing white obstruction light, 40 flashes per minute (fpm)
 - Used primarily for high structures and day protection on antennas where marking may be omitted.
- CL-857 high-intensity flashing white obstruction light, 60 fpm
 - Lighting of catenary crossings
- CL-864 flashing red obstruction light, 20–40 fpm
 - Used for night protection of extensive obstructions and antennas of more than 45 m.
- CL-865 medium-intensity flashing white obstruction light, 40 fpm
 - When operated 24 hr, paint marking may be omitted.
- CL-866 medium-intensity flashing white obstruction light, 60 fpm
 - White catenary lighting.
- CL-885 flashing red obstruction light, 60 fpm
 - Red catenary light.

Table 1: Light Unit Characteristics

Name	Colour	Intensity	Intensity Value (candelas)	Signal Type	Flash Rate flashes per minute
CL-810	red	low	32	steady burning	n/a
CL-856	white	high	200 000	flashing	40
CL-857	white	high	100 000	flashing	60
CL-864	red	medium	2 000	flashing	20 – 40
CL-865	white	medium	20 000	flashing	40
CL-866	white	medium	20 000	flashing	60
CL-885	red	medium	2 000	flashing	60

AGFA

Rotating Obstruction Light

The majority of flashing obstruction light units are of a strobe (capacitor discharge) design. An exception is one type of CL-865 medium-intensity flashing light, which is of a rotating design, i.e. the light display is produced by rotating lenses. Since this particular light unit might otherwise be mistaken for an aerodrome beacon, colour coding is used to produce a sequenced display of white, white, red, white, white, and red.



The rotating type CL-865 also has the same 20 000 candela intensity for nighttime as for daytime operation. The absence of dimming is allowed for two reasons: (1) the specified intensities are minimum requirements and (2) the rotating characteristic does not produce glare to the pilot.

Tower Configurations

Depending on the height of the tower and other factors, the installation on towers and antennas may vary as shown in the figure below.

Configurations of Lighting on Skeletal Structures

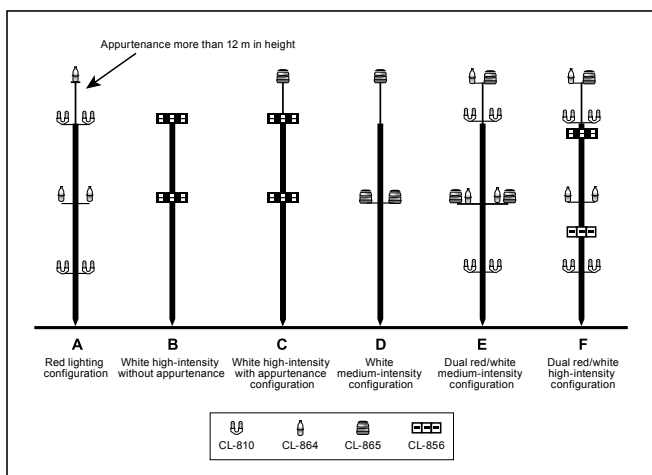

6.6 APPURTENANCES

Where an obstruction is provided with a red obstruction lighting system, any appurtenance 12 m in height will require an obstruction light at the base of the appurtenance. Where such an appurtenance is more than 12 m in height, the light must be installed on the top of the appurtenance. If the appurtenance is not capable of carrying the light unit, the light may be mounted on the top of an adjacent mast.

Where a high-intensity white flashing lighting system is required, appurtenances higher than 12 m in height will require a top-mounted medium-intensity white flashing omnidirectional light unit.

6.7 SUSPENDED CABLE SPAN MARKINGS

Suspended cable spans, such as power line crossings, assessed as being hazardous to air navigation are normally marked with coloured balls suspended from a messenger cable between the top of the support towers. The support towers are obstruction painted. When painting the support towers is not practical, or to provide added warning, shore markers painted international orange and white will be displayed. In some cases, older marker panels that have not been updated are of a checkerboard design.

An alternative method of marking is to use strobe lights on shore-based cable support towers. Normally three levels of lights are installed as follows: one light unit at the top of the structures to provide 360° coverage; two light units on each structure at the base of the arc of the lowest cable; and two light units at a point midway between the top and bottom levels with 180° coverage. The beams of the middle and lower lights are adjusted so that the signal will be seen from the approach direction on either side of the power line. The lights flash sequentially: middle lights followed by the top lights and then the bottom lights in order to display a “fly up” signal to the pilot. The middle light may be removed in the case of narrow power line sags; in this case the bottom lights will flash first then the top lights will flash in order to display a “fly up” signal to the pilot. When determined appropriate by an aeronautical study, medium-intensity white flashing omnidirectional lighting systems may be used on supporting structures of suspended cable spans lower than 150 m AGL.

Obstruction markings on aerial cables (i.e., marker balls) that define aeronautical hazards are generally placed on the highest line for crossings where there is more than one cable. Obstruction markings can also be installed on crossings under the *Navigable Waters Protection Act*. In this case, the marker balls are placed on the lowest power line and are displayed to water craft as a warning of low clearance between the water and an overhead cable.

In accordance with the foregoing, pilots operating at low levels may expect to find power line crossings marked as either an aeronautical hazard or a navigable water hazard. They may be unmarked if it has been determined by the applicable agency to be neither an aeronautical nor a navigable waters hazard. Pilots operating at low altitudes must be aware of the hazards and exercise extreme caution.

MARKERS FOR CABLE SPAN

TOP VIEW

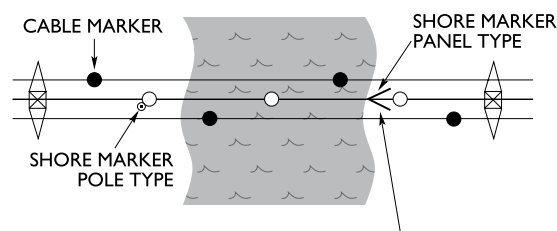

NOTE: For more than one line, markers may be installed alternately.

FRONT VIEW

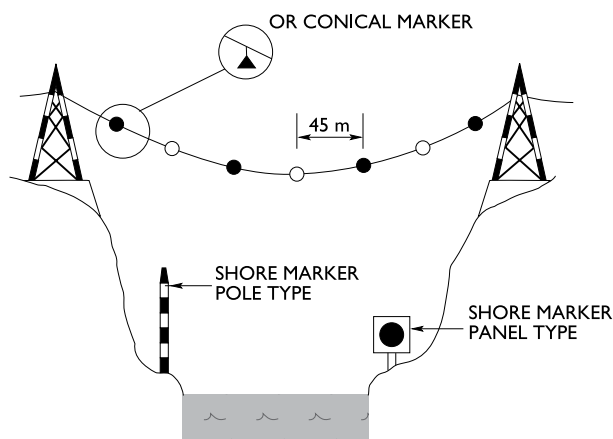

NOTE: Shore markers are to be securely fixed in place and be sufficiently high off the ground to permit unobstructed vision in both directions. The panel type marker is a 6 m square white panel with a circle centred on the panel.

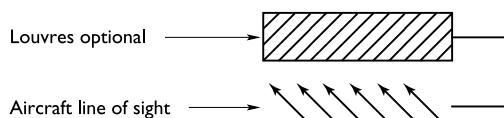

6.8 AIRCRAFT DETECTION SYSTEMS

New technology has recently been developed so that obstacle lighting is only activated when required to alert pilots who are on a flight path that may lead to a collision. The system has economic benefits and minimizes public complaints due to light pollution.

The system uses radar to detect and track aircraft within a specified distance of about 9.3 km. The potential of collision with the obstacle is determined by the aircraft's speed and angle of approach. If there is a risk of collision, the lighting turns on and is followed by an audio warning on the VHF radio. The lighting does not turn on until it is actually needed by the detected aircraft. Even though the system uses radar, no additional equipment is required to be installed on board the aircraft (e.g. transponder).

The lighting is activated approximately 30 s prior to the aircraft reaching the obstacle. The audio warning is transmitted on pre-selected VHF frequencies about 20 s prior to a potential collision. In the case of catenaries, the audio warning will state "POWER LINE, POWER LINE." For other types of obstructions a different message will be sent, as appropriate. The timing for activation of lighting and to begin transmission of the audio warning can be modified as required by the Civil Aviation Authority.

The aircraft detection system has been accepted for use in Canada, and is being approved on a site-by-site basis in the Pacific Region. It is currently installed for some catenary cable crossings and on a ski lift in British Columbia.

Any questions or comments may be directed to the Transport Canada Aerodromes and Air Navigation office in Ottawa or to the Pacific regional office at 604-666-5490.

7.0 AERODROME LIGHTING

7.1 GENERAL

The lighting facilities available at an aerodrome or airport are described in the CFS. Information concerning an aerodrome or airport's night lighting procedures is included as part of the description of lighting facilities where routine night lighting procedures are in effect. Where night lighting procedures are not published for an aerodrome or airport, pilots should contact the aerodrome operator concerned and request that the appropriate lights be turned on to facilitate their intended night operations.

AGA

7.2 AERODROME BEACON

Many aerodromes are equipped with a flashing white beacon light to assist pilots in locating the aerodrome at night. The flash frequency of beacons at aerodromes or airports used by aeroplanes is 20 to 30 evenly spaced flashes per minute. The aerodrome beacon may be of the rotating or capacitor discharge type.

The flash frequency of beacons at aerodromes and heliports used by helicopters only is sequenced to transmit the Morse code letter “H” (groups of four quick flashes) at the rate of three to four groups per minute.

7.3 MINIMUM NIGHT LIGHTING REQUIREMENTS AT AERODROMES

Section 301.07 of the CARs requires that any area of land that is to be used as an aerodrome at night shall have fixed (steady) white lights to mark the runway, and fixed red lights to mark unserviceable (hazardous) areas.

Retroreflective markers may be substituted for lights to mark the runway at aerodromes, provided alignment lights are installed (see AGA 7.19 Reflective Markers). This alternative for night marking of runways, however, is not approved for certified sites.

7.4 UNSERVICEABLE AREA LIGHTING

Unserviceable areas within the manoeuvring area of an aerodrome being used at night are marked by steady burning red lights outlining the perimeter of the unserviceable area(s). Where it is considered necessary in the interest of safety, one or more flashing red lights may be used in addition to the steady red lights.

7.5 APPROACH LIGHTING

The approach lighting systems depicted in the CFS include the following:

7.5.1 Non-Precision Approach Runways

(a) *Low Intensity Approach Lighting System (LIAL)*: This system is provided on non-precision approach runways and consists of twin aviation yellow fixed-intensity light units spaced at 60-m intervals commencing 60 m from the threshold and extending back for a distance of 900 m (terrain permitting).

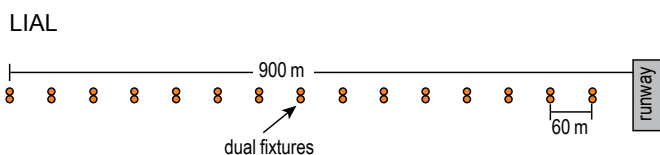

(b) *Omnidirectional Approach Lighting System (ODALS)*: This system is a configuration of seven omnidirectional, variable-intensity, sequenced flashing lights. ODALS provides circling, offset, and straight-in visual guidance for non-precision approach runways. There are five lights on the extended centreline commencing 90 m from the threshold and spaced 90 m apart for 450 m. Two lights are positioned 12 m to the left and right of the threshold. The system flashes towards the threshold, then the two threshold lights flash in unison; the cycle repeats once per second.

ODALS

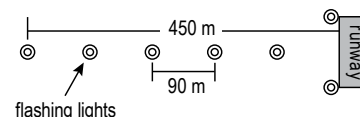

(c) *Medium Intensity Approach Lighting System with Sequenced Flashing Lights (MALSF)*: This system consists of seven bars of variable-intensity lights spaced 60 m apart for 420 m commencing at 60 m from the threshold. The three bars farthest away from the threshold contain a sequenced flashing light unit. These lights flash sequentially towards the threshold, repeating at two cycles per second.

MALSF

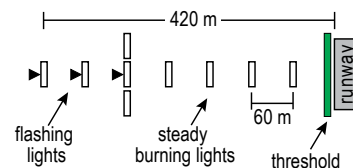

(d) *Medium Intensity Approach Lighting System with Runway Alignment Indicator Lights (MALSR)*: This system consists of a variable-intensity approach lighting system extending 720 m from the threshold. This system consists of the following:

- (i) seven bars of light spaced at 60 m over a distance of 420 m; and
- (ii) five sequenced flashing lights spaced at 60 m over a further distance of 300 m. These lights flash in sequence towards the threshold at a rate of two cycles per second.

The MALSR has the same configuration as the SSALR, but the lights for the former are PAR 38 and for the latter are PAR 56, which has a higher intensity.

MALSR

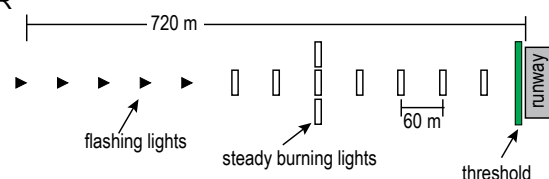

7.5.2 Precision Approach Runways

- (a) *High Intensity Approach Lighting (HIAL) System—CAT I:* This system consists of rows of five white variable-intensity light units spaced at 30 m intervals commencing 90 m from the threshold and extending back for a distance of 900 m (terrain permitting). Additional light bars have been added to the low intensity system (incorporated in this system) because of the lower landing minimum. These are as follows:
- (i) approach threshold bar (green)
 - (ii) contrast bars (red)
 - (iii) imminence of threshold bar (red)
 - (iv) 300 m distance bar (white)

HIAL - CAT I

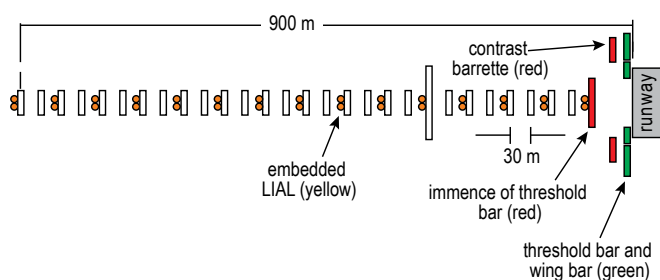

- (b) *Simplified Short Approach Lighting System with Runway Alignment Indicator Lights (SSALR):* This system consists of a variable-intensity approach lighting system extending 720 m from the threshold. This system consists of the following:
- (i) seven bars of light spaced at 60 m over a distance of 420 m; and
 - (ii) five sequenced flashing lights spaced at 60 m over a further distance of 300 m. These lights flash in sequence towards the threshold at a rate of two cycles per second.

SSALR

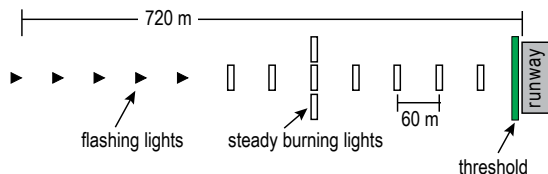

- (c) *Approach Lighting System with Sequenced Flashers—CAT II (ALSF-2):* This system consists of rows of five white variable-intensity light units placed at longitudinal intervals of 30 m commencing 30 m from the threshold and extending for a distance of 720 m. In view of the very low decision height associated with CAT II operations, the following lights are provided in addition to the lights of the CAT I system:
- (i) runway threshold (green)
 - (ii) 150 m distance bar (white with red barrettes)
 - (iii) side barrettes (red)

ALSF-2

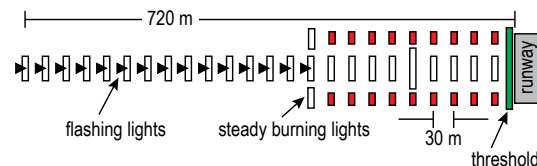

7.6 APPROACH SLOPE INDICATOR SYSTEMS

7.6.1 General

7.6.1.1

An approach slope indicator consists of a series of lights visible from at least 4 NM (2.5 NM for abbreviated installations) designed to provide visual indications of the desired approach slope to a runway (usually 3°). At a certified airport, aircraft following the on-slope signal are provided with safe obstruction clearance to a minimum of 6° on either side of the extended runway centreline out to 4 NM from the runway threshold. Longer runways at certified airports are commonly protected out to 9° on each side of the extended runway centreline. Exceptions will be noted in the CFS. Descent using an approach slope indicator should not be initiated until the aircraft is visually aligned with the runway centreline.

7.6.1.2

The vertical distance from a pilot's eyes to the lowest portion of the aircraft in the landing configuration is called the eye-to-wheel height (EWH), and this distance varies from less than 4 ft (3 m) to up to 45 ft (14 m) for some wide-bodied aircraft, such as the B-747. Consequently, approach slope indicator systems are related to the EWH for the aircraft that the aerodrome is intended to serve and provide safe wheel clearance over the threshold when the pilot is receiving the on-slope indication.

7.6.1.3

Pilots and/or air operators must ensure that the approach slope indicator system to be used is appropriate for the given aircraft type, based on the EWH for that aircraft. If this information is not already available in the Aircraft Flight Manual (AFM) or other authoritative aircraft manuals (e.g. Flight Crew Operating Manual [FCOM]), the aircraft manufacturer should be contacted to determine the EWH information for the given aircraft type.

CAUTION: Failure to assess the EWH and approach slope indicator system compatibility could result in decreased terrain clearance margins and in some cases, even premature contact with terrain (e.g. a controlled flight into terrain [CFIT] accident).

7.6.1.4

The Canadian civil standard for a visual approach slope indicator system is the PAPI. There may be some confusion in terminology, as some airports still have the older systems of visual approach slope indicator (VASI). The VASI and PAPI have the same purpose of descent indication with respect to an approach corridor, but are of a different pattern of light units, as shown below.

7.6.1.5

The VASI and PAPI have lights normally situated on the left side of the runway only. When available strip widths preclude the use of a full system, an abbreviated approach slope indicator, AV or AP, consisting of only two light units, may be installed.

7.6.1.6

Where a visual approach slope indicator system (PAPI or VASI) is provided on a precision approach runway, it will be turned off in weather conditions of less than 500 ft (150 m) ceiling and/or visibility less than 1 mi., unless specifically requested by the pilot. This is to avoid possible contradiction between the precision approach and VASI/PAPI glide slopes.

7.6.2.2 3-BAR VASI (V3)

The 3-BAR VASI (V3) is basically a 2-BAR VASI (V2), with one light unit added to form an additional upwind bar. This provides a greater threshold wheel clearance for aircraft with a large EWH (a wide body). The system then consists of three wing bars:

- upwind bar (added);
- middle bar (upwind bar of V2); and
- downwind bar of V2.

Wide-bodied aircraft use the upwind and middle bars to provide safe wheel clearance, and conventional aircraft (up to 25 ft (7.5 m) EWH) use the middle and downwind bars, as with V2.

Where VASI is provided on a precision approach runway, it will be turned off in weather conditions of less than 500 ft (150 m) ceiling and/or visibility less than 1 mi., unless specifically requested by the pilot. This is to avoid possible contradiction between the precision approach and VASI glide paths.

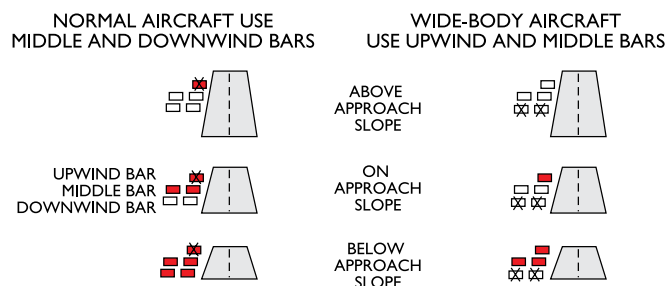

7.6.2 Visual Approach Slope Indicator Systems (VASIS)

7.6.2.1 2-BAR VASI (V1 and V2)

The 2-BAR VASI (V1 and V2) consists of four light units situated on the left side of the runway in the form of a pair of wing bars, referred to as the upwind and downwind wing bars. The wing bars project a beam of white light in the upper part and a red light in the lower part.

- On the approach slope, the upwind bar will show red and the downwind bar will show white.
- Above the approach slope, both upwind and downwind bars will show white.
- Below the approach slope, both upwind and downwind bars will show red.
- Well below the approach slope, the lights of the two wing bars will merge into one red signal.

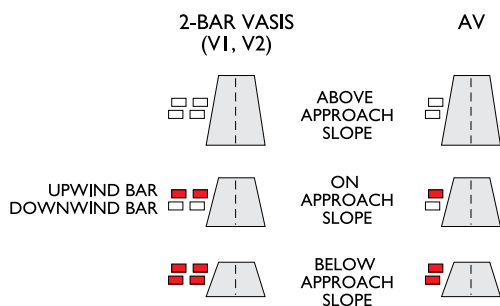

7.6.2.3 Precision Approach Path Indicator (PAPI)

PAPI consists of four light units situated on the left side of the runway in the form of a wing bar.

- On the approach slope, the two units nearest the runway show red, and the two units farthest from the runway show white.
- Slightly above the approach slope, the one unit nearest the runway shows red and the other three show white.
- Further above the approach slope, all four units show white.
- Slightly below the approach slope, the three units nearest the runway show red and the other shows white.
- Well below the approach slope, all four units show red

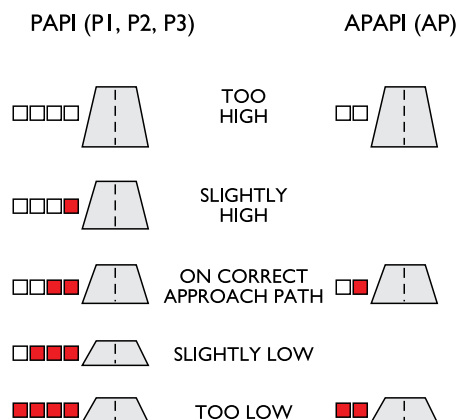

7.6.3 Categories According to EWH in the Approach Configuration

7.6.3.1

Approach slope indicator systems are categorized according to the EWH in the approach configuration, as shown in tables 7.1 and 7.2 below:

NOTE: In this situation, the EWH is not the physical dimension of the aircraft on the ground, but rather the EWH in the approach configuration, which is determined by the glide slope angle and the pitch angle for maximum certified landing weight at V_{ref} .

7.6.3.2

The VASI systems are designed for aircraft height groups as indicated in Table 7.1 for categories AV, V1, V2 and V3. The greater the value of the EWH in the approach configuration, the farther the VASI is installed upwind from the threshold to enable a minimum eye height over threshold (MEHT).

Table 7.1 VASI Categories

Category	System	Aircraft height group EWH in the approach configuration
AV	2-BAR VASI	0 ft (0 m) < 10 ft (3 m)
V1	2-BAR VASI	0 ft (0 m) < 10 ft (3 m)
V2	2-BAR VASI	10 ft (3 m) < 25 ft (7.5 m)
V3	3-BAR VASI	25 ft (7.5 m) < 45 ft (14 m)

< means up to but not including

7.6.3.3

The PAPI is designed for aircraft height groups as indicated in Table 7.2 for categories AP, P1, P2 and P3. The greater the value of the EWH in the approach configuration, the farther the PAPI is installed upwind from the threshold to enable an MEHT.

Table 7.2 PAPI Categories

Category	Aircraft height group EWH in the approach configuration
AP	0 ft (0 m) < 10 ft (3 m)
P1	0 ft (0 m) < 10 ft (3 m)
P2	10 ft (3 m) < 25 ft (7.5 m)
P3	25 ft (7.5 m) < 45 ft (14 m)

< means up to but not including

7.6.3.4

The case of PAPI is shown in Figure 7.1. The approach corridor is defined by the setting angles of units C and B. The MEHT is defined by the angle M, which is 2 min of arc below the angle B. This accounts for the pink transition sector. The EWH in the approach configuration is the vertical distance of the eye path from the wheel path. The available MEHT is the sum of the EWH and the prescribed wheel clearance. The distance D for location of the PAPI from the threshold is calculated using the tangent of the angle M.

Figure 7.1 PAPI: Pilot eye path to wheel path

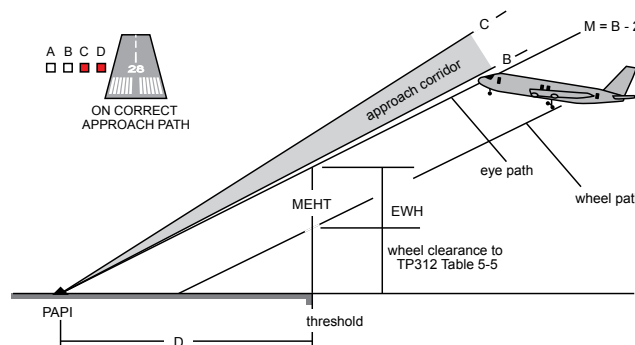

7.6.4 Knowing your EWH

7.6.4.1

As illustrated in Figure 7.1, for a particular category of PAPI, there is an available wheel clearance, which is why knowing the EWH in the approach configuration is important. If your aircraft belongs in the aircraft height group for P3 PAPI, using a P2 PAPI means having much less wheel clearance at threshold crossing. Figure 7.1 also shows why, in general, flying the system with indication as being below the approach corridor (e.g. three red and one white) is not recommended.

7.7 RUNWAY IDENTIFICATION LIGHTS

7.7.1 Runway Identification Lights (RILS)

These are provided at aerodromes where terrain precludes the installation of approach lights, or where unrelated non-aeronautical lights or the lack of daytime contrast reduces the effects of approach lights. Aerodromes equipped with RILS are listed in the CFS and the RILS system is indicated by the notation "AS".

RILS are operated to accommodate arriving aircraft as follows:

- (a) *by day*: when the visibility is 5 mi. or less, they are turned on and will be left on unless the pilot requests that they be turned off.
- (b) *by night*: these lights are operated in conjunction with the approach and runway lights, but can be turned off at the pilot's request.

7.7.2 Visual Alignment Guidance System (VAGS)

The VAGS consists of two lights similar to those used in RILS. However, by means of light beam rotation, the pilot is presented with a sequenced display, as shown in the figure below. The display directs the pilot towards the runway/helipad axis, where he or she then sees the lights flash simultaneously.

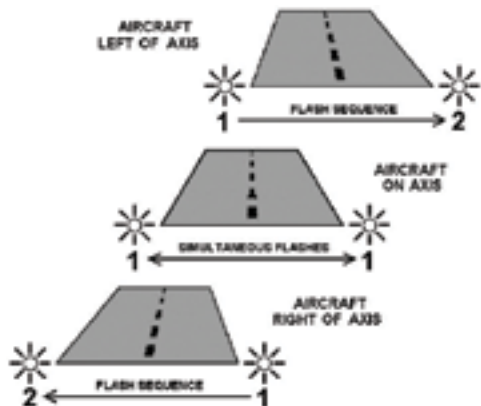

7.8 RUNWAY LIGHTING

A runway that is used at night shall display 2 parallel lines of fixed white lights visible for at least 2 mi. to mark take-off and landing areas. These lights are arranged so that:

- (a) the minimum distance between parallel lines is 23 m, and the maximum is 60 m;
- (b) the maximum distance between lights in the parallel lines is 60 m; and
- (c) each light in the parallel lines is aligned opposite the other and at right angles to the centreline of the take-off and landing area.

7.8.1 Runway Edge Lights

These are variable-intensity white lights at the runway edges along the full length of the runway spaced at 60-m intervals, except at intersections with other runways. On some runways, a 600-m section of lights or the last third of the runway at the remote end—whichever is shorter—may show yellow. The units are light in weight and mounted in a frangible manner.

7.8.2 Runway Threshold End Lights

Runway threshold/end indication is provided by green and red light units in the form of a pair of bars along the threshold on each side of the runway centreline, where there is an ODALS or no approach lighting. Red shows in the direction of takeoff and green shows in the approach direction.

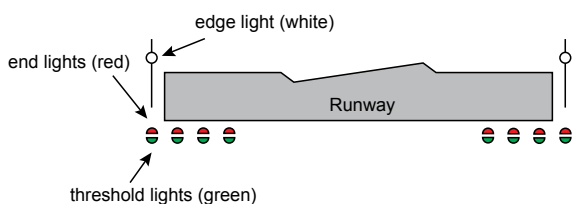

Where approach lighting such as MALSR, MALSF or SSALR is provided, the green threshold lighting extends along the full width of the runway.

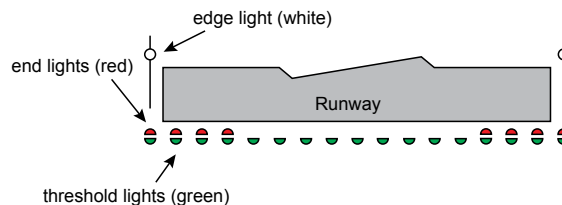

Where an ALSF-2 is provided, the green threshold lighting is extended farther as wing bars to each side of the runway.

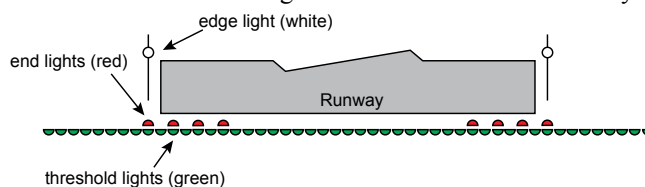

7.9 DISPLACED RUNWAY THRESHOLD LIGHTING

Where runway thresholds have been displaced they are lighted as follows:

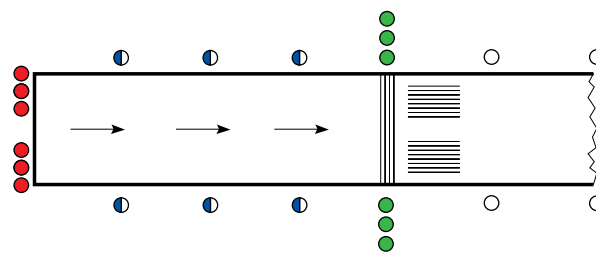

7.10 RUNWAY CENTRELINE LIGHTING

Runway centreline lighting is provided on CAT II and CAT III runways. It consists of variable-intensity lights installed on the runway surface spaced at intervals of 15 m. The lights leading in the take-off or landing direction are white to a point 900 m from the runway end. They then change to white and red until 300 m from the runway end, at which point they become red.

7.11 RUNWAY TOUCHDOWN ZONE LIGHTING

Touchdown zone variable intensity white lights are provided on CAT II and CAT III instrument runways. They consist of bars of three inset lights per bar disposed on either side of the runway centreline, spaced at 30 m intervals commencing 30 m from the threshold, extending 900 m down the runway. The lights are unidirectional, showing in the direction of approach to landing.



7.12 RAPID-EXIT TAXIWAY LIGHTING

Rapid-exit taxiway lights are alternating green and yellow in colour and are installed on the runway surface commencing approximately 60 m before the turn and continuing with the alternating colours until beyond the HOLD position. Once beyond the HOLD position, the colour pattern reverts to continuous green.

7.13 TAXIWAY LIGHTING

Taxiway edge lights are blue in colour and are spaced at 60-m intervals. Where a taxiway intersects another taxiway or a runway, two adjacent blue lights are placed at each side of the taxiway. To facilitate the identification of the taxiway entrance on departure from the apron, the intersection of an apron with a taxiway is indicated by two adjacent yellow lights at taxiway/apron corners.

Taxiway centreline lights are green in colour and are installed on the taxiway surface. They are spaced at 15-m intervals with less spacing on taxiway curves.

7.14 STOP BARS

Stop bars are provided at every taxi-holding position serving a runway when it is intended that the runway will be used in visibility conditions below RVR1200 ($\frac{1}{4}$ SM). Stop bars are located across the taxiway at the point where it is desired that traffic stop and consist of lights spaced at intervals of 3 m across the taxiway. They appear showing red in the intended direction of approach to the intersection or taxi-holding position.

Where the stop bar is collocated with taxiway centreline lighting, a 90-m segment of the taxiway centreline lighting beyond the stop bar is turned off when the stop bar is illuminated. The stop bar is illuminated again after a timed duration or by means of sensors installed on the taxiway.

One should never cross an illuminated stop bar, even with a clearance from ATC.

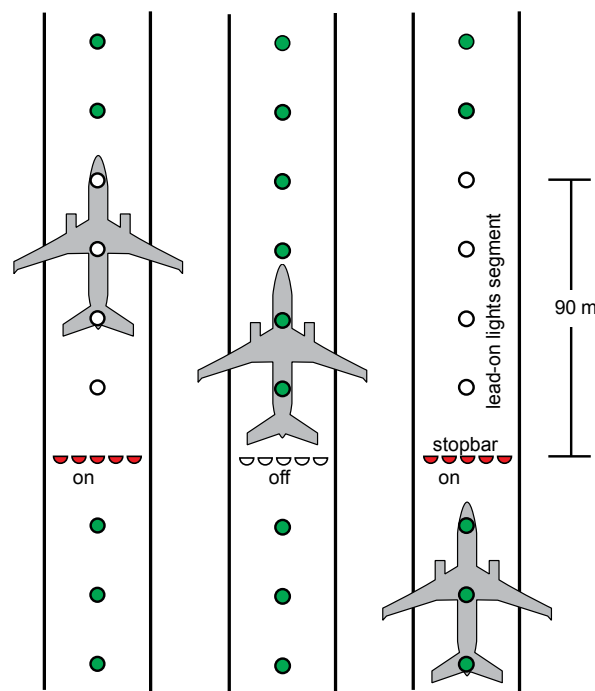

7.15 RUNWAY GUARD LIGHTS

Runway guard lights are provided at each taxiway/runway intersection to enhance the conspicuity of the holding position for taxiways supporting runway operations below a visibility value of RVR2600 ($\frac{1}{2}$ SM). They consist of yellow unidirectional lights that are visible to the pilot of an aircraft taxiing to the holding position, but their configuration may vary:

- They can consist of a series of lights spaced at intervals of 3 m across the taxiway. Where this is the case, the adjacent lights illuminate alternately and even lights illuminate alternately with odd lights; or
- They can consist of two pairs of lights, one on each side of the taxiway adjacent to the hold line. Where this is the case, the lights in each unit illuminate alternately.

7.16 HELIPORT LIGHTING

Where a heliport is used at night, the perimeter of the TLOF may be lighted by yellow perimeter lights or by floodlighting.

- Yellow perimeter lights:* Where the TLOF is circular, no fewer than eight yellow lights are used to mark the perimeter. In a rectangular layout, the perimeter is marked by a minimum of four yellow lights on each side, with a light at each corner.

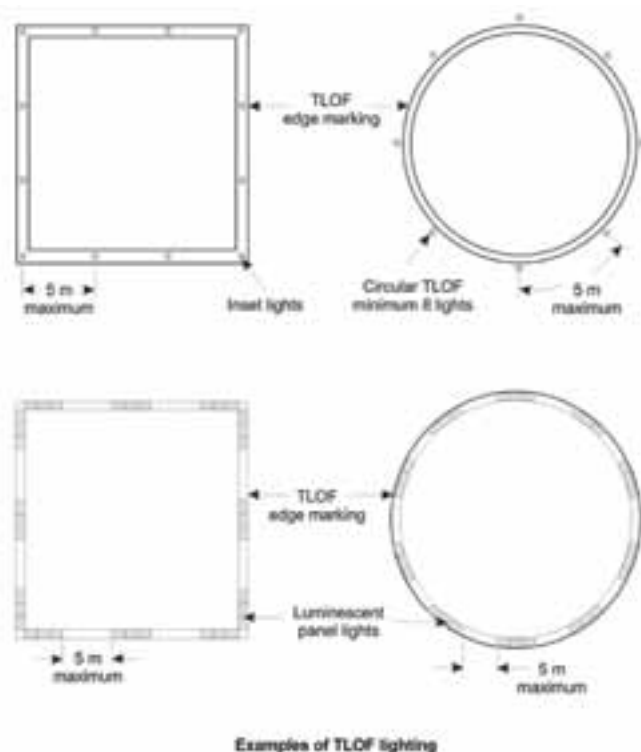

(b) *Floodlighting*: When provided, the floodlighting will illuminate the TLOF such that the perimeter marking of the TLOF is visible. Floodlight units will be located beyond the perimeter of the FATO.

NOTE: Perimeter lighting or reflective tape may be used in addition to floodlighting.

7.16.1 FATO Lighting

A FATO perimeter is marked by white or green lights in the same configuration as the TLOF perimeter lighting. Where a TLOF is not located within a FATO, the aiming point will be defined by at least seven red aeronautical ground lights located on the triangular marking.

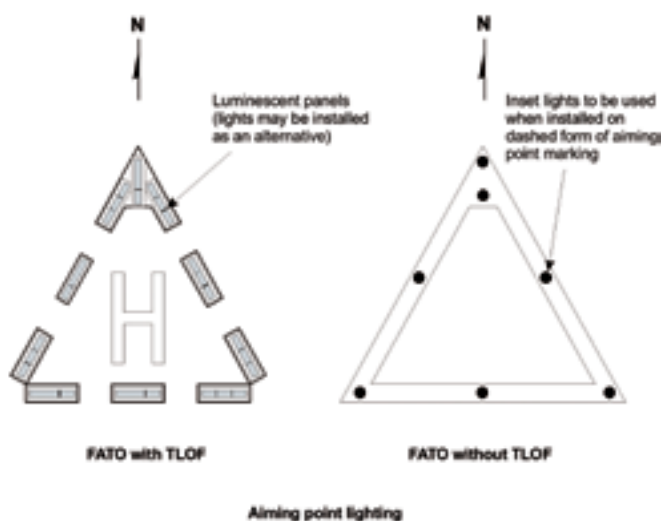

7.16.2 Approach/Take-Off Direction Lights

At some heliports, where it is necessary to follow preferred approach and take-off paths to avoid obstructions or noise sensitive areas, the direction of the preferred approach and take-off routes will be indicated by a row of five yellow fixed omnidirectional lights outside the FATO.

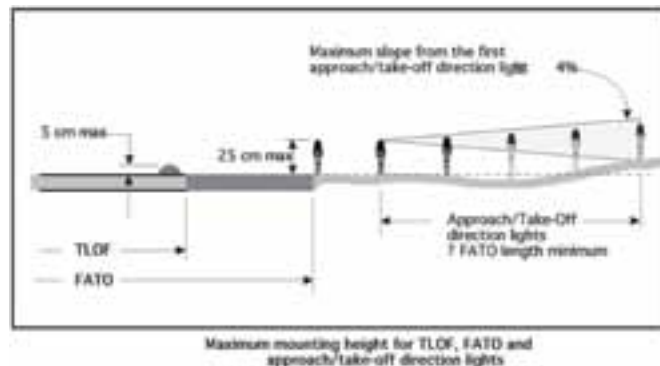

7.17 EMERGENCY LIGHTING

Airports with precision approaches (CAT I, II, and III) in Canada are equipped with a secondary power system for visual aids lighting. This system is normally capable of assuming the electrical load within approximately 15 s for CAT I operations, and within 1 s for CAT II and III operations.

7.18 AIRCRAFT RADIO CONTROL OF AERODROME LIGHTING (ARCAL)

ARCAL systems are becoming more prevalent as a means of conserving energy, especially at aerodromes and airports not staffed on a continuous basis or where it is not practicable to install a land line to a nearby FSS. Aside from obstacle lights, some or all of the aerodrome and airport lighting may be radio-controlled.

Control of the lights should be possible when aircraft are within 15 NM of the aerodrome or airport. The frequency range is 118 to 136 MHz.

Activation of the system is via the aircraft VHF transmitter and is effected by depressing the push-to-talk button on the microphone a given number of times within a specified number of seconds. Each activation will start a timer to illuminate the lights for a period of approximately 15 min. The timing cycle may be restarted at any time during the cycle by repeating the specified keying sequence. It should be noted that ARCAL Type K runway identification lights (code AS) can be turned off by keying the microphone three times on the appropriate frequency. The code for the intensity and the lighting period varies for each installation. Consequently, the CFS must be consulted for each installation.

NOTE: Pilots are advised to key the activating sequence when commencing their approach, even if the aerodrome or airport lighting is on. This will restart

AGFA

the timing cycle so that the full 15-min cycle is available for their approach.

8.0 AIRCRAFT RESCUE AND FIRE FIGHTING (ARFF)

7.19 RETROREFLECTIVE MARKERS

Some aerodromes may use retroreflective markers in place of lights to mark the edges of runways or helipads. These retroreflective markers are approved for use on runways at registered aerodromes only; however, they may be used as a substitute for edge lighting on taxiways or apron areas at some certified airports.

Retroreflective markers are to be positioned in the same manner as runway lighting described in earlier paragraphs of this chapter. Therefore, when the aircraft is lined up on final approach, retroreflective markers will provide the pilot with the same visual presentation as normal runway lighting. A fixed white light or strobe light shall be installed at each end of the runway to assist pilots in locating the aerodrome and aligning the aircraft with the runway. Similarly, retroreflective markers at heliports are to be positioned in the same pattern as prescribed for helipad edge lighting.

The approved standard for retroreflective markers requires that they be capable of reflecting the aircraft landing lights so that they are visible from a distance of 2 NM. Pilots are cautioned that the reflective capabilities of retroreflective markers are greatly affected by the condition of the aircraft landing lights, the prevailing visibility and other obscuring weather phenomena. Therefore, as part of preflight planning to an aerodrome using retroreflective markers, pilots should exercise added caution in checking the serviceability of their aircraft landing lights and making provision for an alternate airport with lighting in case of an aircraft landing light failure.

8.1 GENERAL

Airports obligated to provide ARFF are found in the schedule under CAR 303. Other airports choosing to provide ARFF must do so in accordance with CAR 303.

The primary responsibility of an ARFF service is to provide a fire-free egress route for the evacuation of passengers and crew following an aircraft accident.

8.2 ARFF HOURS OF AVAILABILITY

The aerodromes or airports providing ARFF are required to publish the hours during which an ARFF service is operated in the CFS under the ARFF annotation.

8.3 CLASSIFICATION SYSTEM

The following table identifies the critical category for fire fighting as it relates to the aircraft size, the quantities of water and complementary extinguishing agents, the minimum number of ARFF vehicles and the total discharge capacity. For ease of interpretation, the table is a combination of the two tables found under CAR 303.

Aeroplane Category	Aeroplane Overall Length	Maximum Fuselage Width (metres)	Quantity of Water (litres)	Quantity of Complementary Agents (kilograms)	Minimum Number of Aeroplane Firefighting Vehicles	Total Discharge Capacity (litres per minute)
1	less than 9 m	2	230	45	1	230
2	at least 9 m but less than 12 m	2	670	90	1	550
3	at least 12 m but less than 18 m	3	1 200	135	1	900
4	at least 18 m but less than 24 m	4	2 400	135	1	1 800
5	at least 24 m but less than 28 m	4	5 400	180	1	3 000
6	at least 28 m but less than 39 m	5	7 900	225	2	4 000
7	at least 39 m but less than 49 m	5	12 100	225	2	5 300
8	at least 49 m but less than 61 m	7	18 200	450	3	7 200
9	at least 61 m but less than 76 m	7	24 300	450	3	9 000
10	at least 76 m	8	32 300	450	3	11 200

8.4 ARFF STANDBY REQUEST

Local standby means the level of response when an aircraft has, or is suspected to have, an operational defect. The defect would normally cause serious difficulty for the aircraft to achieve a safe landing.

Full emergency standby means the level of response when an aircraft has, or is suspected to have, an operational defect that affects normal flight operations to the extent that there is possibility of an accident.

When informed that an emergency has been declared by a pilot, the airport ARFF unit will take up emergency positions adjacent to the landing runway and stand by to provide assistance. Once response to an emergency situation has been initiated, the ARFF unit will remain at the increased state of alert until informed that the pilot-in-command has terminated the emergency. After the landing, ARFF will intervene as necessary and, unless the pilot-in-command authorizes their release, escort the aircraft to the apron and remain in position until all engines are shut down.

In order to adequately respond, a pilot request to “stand by in the fire hall” is not appropriate. Pilots are reminded, however, that the ARFF unit will terminate their alert posture when informed by the pilot that the emergency situation no longer exists.

8.5 ARFF DISCREET COMMUNICATION

The capability to communicate on a discreet frequency is normally available at airports that provide ARFF services.

9.0 AIRCRAFT ARRESTING SYSTEMS

9.1 ENGINEERED MATERIAL ARRESTING SYSTEMS (EMAS)

NOTE: No EMAS are currently installed in Canada. This section is being published to educate the aviation community prior to EMAS being installed in Canada.

9.1.1 System Description

EMAS is an arresting system designed for transport category aeroplanes in the event of a runway overrun. An EMAS bed is designed to stop an overrunning aeroplane by exerting predictable deceleration forces on its landing gear as the EMAS material crushes. The strength of the arrester bed is designed to decelerate the aeroplane without structural failure to the landing gear. The beds are made up of a grouping of blocks of crushable cellular concrete that will reliably and predictably crush under the weight of an aeroplane.

In order to arrest an aeroplane overrunning a runway end, EMAS beds are placed beyond the end of a runway and in alignment with the extended runway centerline.



Photograph of an EMAS installation
(The EMAS bed is the grey area under the yellow chevrons)

9.1.2 System Depiction

The aerodrome sketch will show the location and dimensions of the EMAS beds. In the example below, the EMAS bed is shown as an outlined box with diagonal lines running through it. The dimensions are provided in feet.

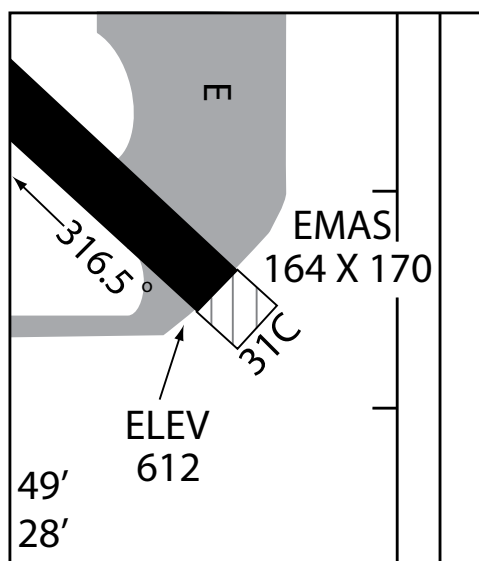

EMAS depiction on an aerodrome sketch

9.1.3 Pilot Considerations for Engagement

Prior to using a runway, pilots should be aware of the presence of an EMAS bed. Pilots should review the aerodrome sketch and other aerodrome information to determine if the runway that they will be using is equipped with an EMAS.

During the take-off or landing phase, if a pilot determines that the aeroplane will exit the runway end and enter the EMAS, the following procedure should be followed:

- (a) continue to follow rejected-takeoff procedures or, if landing, maximum-braking procedures outlined in the aircraft flight manual, regardless of aeroplane speed upon exiting the runway;
- (b) continue straight ahead—do not veer left or right. Having all of the aeroplane’s landing gear enter the bed will maximize the EMAS’s stopping capability. Veering to the side may result in the aeroplane missing the bed altogether or having only one set of wheels enter the bed with reduced effectiveness. The quality of deceleration will be best within the confines of the bed. The further the aeroplane travels into the bed, and into deeper concrete, the greater the deceleration;
- (c) do not take any action—the arrester bed is a passive system, similar to other traditional arresting systems such as cables, chains and aircraft netting;
- (d) do not attempt to taxi or otherwise move the aeroplane once stopped;

- (e) use standard aircraft emergency ground egress procedures, should an emergency egress be required. Where the surface of the bed has been breached, the loose material will crush underfoot. During egress, it is important to note that the two sides and the back of the arrester bed have continuous steps built in to help provide easy access for responding ARFF vehicles and to enable passengers to safely step off the bed; and
- (f) use slides or aircraft stairs to deplane passengers after an EMAS arrestment as the EMAS bed will not provide a stable base for the air stairs.

9.2 MILITARY AIRCRAFT ARRESTING SYSTEMS

9.2.1 Background

Some civil airports and military aerodromes are equipped with aircraft arresting systems. An aircraft arresting system usually consists of two sets of gear, called energy absorbers, with one located on each side of the runway, normally approximately 460 m from the threshold. These energy absorbers are interconnected by an arrester cable, which is attached to a nylon tape that is wound onto a tape storage drum (reel) on each energy absorber. In order to locate the energy absorbers away from the edge of the runway, runway edge sheaves are located next to the runway edge. The runway edge sheaves act as a guide (pulley) for the tape and have sloped sides to permit an aircraft to roll over them.

When the tailhook of a fighter aircraft engages the cable, the tape storage drums start to turn. The energy absorbers apply a braking force to the storage drums, which in turn slows the aircraft and brings it to a stop.

9.2.2 Markings

For identification, yellow circles are painted across the runway at the location of the aircraft arrester cable. A lighted sign with a yellow circle beside the runway marks the location during darkness.

9.2.3 Operations

At civil airports, civil aeroplane operations will not be permitted while the arrester cable is deployed across the runway. At military aerodromes, civil aeroplane operations may be permitted with the arrester cable deployed across the runway.

9.2.4 Damage Hazards

- (a) Cables: Pilots are advised to avoid crossing the aircraft arrester cable at speeds in excess of 10 mph, as a wave action may develop in the cable, which could damage the aircraft. This is particularly important for nose-wheel aircraft having minimal propeller or undercarriage-door clearance, or wheel fairings. Tail-wheel aircraft may also sustain damage if the tail wheel engages the cable.
- (b) Runway edge sheaves: The runway edge sheaves are located next to the runway edge, on the runway shoulder, and they are above grade. The two sides perpendicular to the runway are sloped, but the other two sides, parallel to the runway, are vertical. The runway edge sheaves are not frangible and may cause damage to an aeroplane that contacts or rolls over one.
- (c) Energy absorbers: The energy absorbers are normally located beside the graded area of the runway strip (at a distance greater than 61 m from the runway centreline). The energy absorbers are not frangible and will cause damage to an aeroplane that contacts one.

9.2.5 Information for Pilots

Pilots will normally be advised of the status of the arrester cable through ATIS or by ATC. The existence of an aircraft arresting system should be included in the runway data section of the CFS. The location of an aircraft arresting system should also be depicted on the aerodrome sketch.

COM – COMMUNICATIONS

1.0 GENERAL INFORMATION

1.1 GENERAL

This section contains a description of the radio navigation aids and communication facilities available in Canada and in the Gander Oceanic Control Area.

1.2 RESPONSIBLE AUTHORITY

Enquiries relating to regulations and standards for communication, navigation, surveillance (CNS) and air traffic management (ATM) systems in Canada should be addressed to:

Aerodrome and Air Navigation Standards (AARTA)
 Transport Canada
 Ottawa ON KIA 0N8
 Tel.: 613-998-9855
 Fax: 613-954-1602
 E-mail: *ron.carter@tc.gc.ca*

1.3 PROVISION OF SERVICES

1.3.1 NAV CANADA

NAV CANADA is responsible for the installation, maintenance and operation of the majority of aeronautical telecommunication systems in Canada (see GEN 1.1 for address). This includes the operation of a network of area control centres, terminal control units, airport control towers and flight service stations used for the provision of air traffic services. The types of services provided by these facilities are described in RAC 1.1.

1.3.2 Canadian Base Operators (CBO)

At Portage la Prairie/Southport Airport, Manitoba, Canadian Base Operators is responsible for the installation and operation of the aeronautical telecommunication systems. Midwest ATC Canada is responsible for the provision of air traffic services. Enquiries should be addressed to:

Canadian Base Operators (CBO)
 P.O. Box 241
 Southport MB R0H 1N0
 Tel.: 204-428-2401
 Fax: 204-428-2419

1.3.3 Other Telecommunication System Operators

A number of CNS/ATM systems throughout Canada are owned and operated by individuals, companies or government. See COM 3.1.1 for details.

2.0 LOCATION INDICATORS

2.1 GENERAL

Responsibility for Canadian location indicators rests with the Aeronautical Information Services Division of NAV CANADA. Location indicators are listed and updated every 56 days in the CFS.

3.0 RADIO NAVIGATION AIDS

3.1 GENERAL

The following types of radio navigation and surveillance systems exist in Canada, although signal coverage cannot be guaranteed in all parts of the Canadian domestic airspace:

- distance measuring equipment (DME)
- en route and terminal radar
- instrument landing system (ILS)
- localizer (LOC)
- global navigation satellite system (GNSS)
- non-directional beacon (NDB)
- precision approach radar (PAR)
- tactical air navigation (TACAN)
- VHF direction finder (VDF)
- VHF omnidirectional range (VOR)
- VHF omnidirectional range and
- tactical air navigation (VORTAC).

A complete list of all Canadian NDBs, VORs, VORTACs and TACANs is contained in the CFS.

3.1.1 Non-NAV CANADA Navigation Aids

Some non-NAV CANADA owned navigation aids (NAVAIDs) are shown on aviation charts and maps. They are depicted as ‘private’, but must meet ICAO standards as required by CAR 802.02.

The status of non-NAV CANADA NAVAIDs used in instrument approaches is normally provided through the NOTAM system.

COM

3.1.2 Interference with Aircraft Navigational Equipment

Some portable electronic devices can interfere with aircraft communications and radio navigation systems. The radiation produced by FM radio receivers and television broadcast receivers falls within the ILS localizer and VOR frequency band, while the radiation produced by the AM radio receivers falls into the frequency range of ADF receivers. This radiation could interfere with the correct operation of ILS, VOR and ADF equipment. Pilots are therefore cautioned against permitting the operation of any portable electronic device on board their aircraft during takeoff, approach and landing. See COM Annex B for more information.

After extensive testing, Industry Canada (IC) has concluded that the switching on or use of hand-held electronic calculators can cause interference to airborne ADF equipment in the 200 to 450 kHz frequency range when the calculator is held or positioned within 5 feet of the loop or sense antenna, or lead-in cable installation of the system. Pilots, especially of small aircraft and helicopters, are therefore cautioned against allowing the operation of calculators on board their aircraft while airborne.

3.2 REMOVAL OF IDENTIFICATION

During periods of routine or emergency maintenance, the identification is removed from NDBs, VORs, DMEs, TACANs, and ILSs. The removal of this identification warns pilots that the facility may be unreliable even though it transmits. Under these circumstances the facility should not be used. Similarly, prior to commissioning, a new facility (particularly VOR or ILS) may transmit with or without identification. In such cases, the facility is advertised as being 'ON TEST' and it should not be used for navigation.

3.3 ACCURACY, AVAILABILITY AND INTEGRITY OF NAVIGATION AIDS

Aviation navigation systems must meet stringent accuracy, availability and integrity requirements as specified in ICAO Annex 10. These terms may be defined as follows:

Accuracy – conformance with the ICAO standards, i.e., course guidance for the intended operation, whether it be en route navigation, non-precision approach or precision approach systems, must meet the required standards;

Availability – the proportion of time that the system is available for operational use versus the proportion of time that it is not available; and

Integrity – the ability of the systems to provide a warning if it is not providing service or providing false information, e.g., warning flags on ILS and VOR cockpit displays.

Operators of aeronautical telecommunications systems shall ensure that they meet these stringent standards. This may be achieved through:

- (a) *electronic means* – the provision of alternate or redundant circuitry for the electronic elements of the NAVAID;
- (b) *emergency back-up power* – all precision approach aids are provided with emergency power and all TACANs for which NAV CANADA has responsibility are provided with emergency power.

Other NAVAIDs provided with emergency power are:

- (i) *within terminal RADAR coverage* – one primary terminal NAVAID, and
 - (ii) *outside of RADAR coverage* – all NAVAIDs which are used for airways or air routes and one primary NAVAID at each aerodrome with a published instrument approach.
- (c) *Monitoring* – is accomplished in three ways:
- (i) *Executive monitoring* is an electronic means in which the system checks its critical parameters and in the event of an out of tolerance condition, either changes to an auxiliary back-up equipment or shuts the system down if there is no redundancy or if the redundant circuit is also failed. This monitoring is continuous.
 - (ii) *Status monitoring* is the automatic notification, either to the maintenance centre or to an operational position, that the system has taken executive action and the navigation system is off-the-air. Many NAVAIDs are not continuously status-monitored.
 - (iii) *Pilot monitoring* is when pilots tune and identify NAVAIDs prior to use and monitor the indicator displays to ensure they are appropriate. When flying instrument approach procedures, particularly NDB approaches, it is recommended that pilots aurally monitor the NAVAID identifier.

(d) *Flight Inspection* – NAVAIDs are flight inspected by specially equipped aircraft on a regular basis to ensure that standards are met; and

(e) *NOTAM* – when NAVAIDs are identified as not meeting the required performance standard, NOTAM are issued to advise pilots of the deficiency.

The end result of these combined efforts is a safe and reliable air navigation system which meets the established standards. Nevertheless, prior to using any NAVAID, pilots should:

- (a) check NOTAM prior to flight for information on NAVAID outages. These may include scheduled outages for maintenance or calibration. For remote aerodromes, or aerodromes with Community Aerodrome Radio Stations (CARS), it is recommended that pilots contact the CARS observer/communicator or the aerodrome operator prior to flight to determine the condition of the aerodrome, availability of services, and the status of NAVAIDs;
- (b) ensure that on board navigation receivers are properly tuned and that the NAVAID identifier is aurally confirmed; and
- (c) visually confirm that the appropriate indicator displays are presented.

3.4 PILOT REPORTING OF ABNORMAL OPERATION OF NAVIGATION AIDS

It is the responsibility of pilots to report any NAVAID failure or abnormality to the appropriate ATS facility. If it is not practical to report while airborne, a report should be filed after landing.

Reports should contain:

- (a) the nature of the abnormal operation detected by the pilot, and the approximate magnitude and direction of any course shift (if applicable). The magnitude may be either in miles or degrees from the published bearing;
- (b) the approximate distance of the aircraft from the NAVAID when the observation was made; and
- (c) the time and date of the observation.

3.5 VHF OMNIDIRECTIONAL RANGE

The VHF Omnidirectional Range (VOR) is a ground-based, short distance NAVAID which provides continuous azimuth information in the form of 360 usable radials to or from a station. It is the basis for the VHF airway structure. It is also used for VOR non-precision instrument approaches.

- (a) *Frequency Band:* The frequency range 108.1 to 117.95 MHz is assigned to VORs. Frequency assignment has been in 0.1 MHz (100 kHz) increments. However, in some areas the number and proximity of VOR installations are such that existing spacing does not allow for a sufficient number of frequencies. In these areas additional channels will be obtained by reducing the spacing to 0.05 MHz (50 kHz).

The implication for users is that, in airspace serviced solely by VOR, aircraft equipped with VOR receivers which cannot be tuned to two decimal places (e.g., 115.25 MHz)

may not be able to operate under IFR. Of course, RNAV, where approved for use, may provide an alternative means.

Receivers with integrated DME (i.e., VOR/DME receivers) normally select the associated DME “Y” channel automatically, while stand alone DME receivers display the “X” and “Y” channels separately.

- (b) *Range:* VOR reception is subject to line-of-sight restrictions and range varies with aircraft altitude. Subject to shadow effect, reception at an altitude of 1 500 feet AGL is about 50 NM. Aircraft operating above 30 000 feet normally receive VOR at a distance of 150 NM or more.
- (c) *Voice Communication and Identification:* A VOR may be provided with a voice feature. Those without voice are identified on the aeronautical charts and in CFS. Identification is accomplished by means of a three-letter location indicator keyed in Morse code at regular 7.5 second intervals.
- (d) *VOR Courses:* Theoretically, an infinite number of courses (radials) are radiated from a VOR station; however, in actual practice, 360° are usable under optimum conditions. The accuracy of course alignment for published VOR radials is $\pm 3^\circ$. Unpublished radials are not required to meet a particular standard of accuracy and may be affected by siting difficulties. Any significant anomalies in these unpublished radials from VOR serving an aerodrome will be published in the CFS.

3.5.1 VOR Receiver Checks

In areas where RNAV routes have not been published, VOR remains the primary NAVAID for use in Canada. It is important that the accuracy of the aircraft equipment be checked in accordance with principles of good airmanship and aviation safety.

While standard avionics maintenance practices are used for checking aircraft VOR receivers, dual VOR equipment may be checked by tuning both sets to the same VOR facility and noting the indicated bearings to that station. A difference greater than 4° between the aircraft’s two VOR receivers indicates that one of the aircraft’s receivers may be beyond acceptable tolerance. In such circumstances, the cause of the error should be investigated and, if necessary, corrected before the equipment is used for an IFR flight.

3.5.2 VOR Check Point

VOR check point signs indicate a location on the aerodrome manoeuvring surface where there is a sufficiently strong VOR signal to check VOR equipment against the designated radial. The indicated radial should be within 4° of the posted radial and the DME should be within 0.5 NM of the posted distance. If beyond this tolerance, the cause of the error should be corrected before the equipment is used for IFR flight.

3.5.3 Airborne VOR Check

Aircraft VOR equipment may also be checked while airborne by flying over a landmark located on a published radial and noting the indicated radial. Equipment which varies more than $\pm 6^\circ$ from the published radial should not be used for IFR navigation.

3.6 NDB

NDBs combine a transmitter with an antenna system providing a non-directional radiation pattern within the low frequency (LF) and medium frequency (MF) bands of 190–415 kHz and 510–535 kHz. NDBs are the basis of the LF/MF airway and air route system. In addition, they function as marker beacons for ILS as well as non-precision approach aids for NDB instrument approaches.

- (a) *Identification:* Identification consists of two- or three-letter or number indicators keyed in Morse code at regular intervals. (Private NDBs consist of a letter/number combination.)
- (b) *Voice Feature:* Voice transmissions can be made from NDBs, unless otherwise indicated on the aeronautical charts and in the CFS.
- (c) *Classification:* NDBs are classified by high, medium or low power output as follows:
- “H” power output 2 000 W or more;
 - “M” power output 50 W to less than 2 000 W; or
 - “L” power output less than 50 W.
- (d) *Accuracy:* NDB systems are flight checked to an accuracy of at least $\pm 5^\circ$ for an approach and $\pm 10^\circ$ for enroute. However, much larger errors are possible due to propagation disturbances caused by sunrise or sunset, reflected signals from high terrain, refraction of signals crossing shorelines at less than 30° and electrical storms.

3.7 DISTANCE MEASURING EQUIPMENT

Distance Measuring Equipment (DME) functions by means of two-way transmissions of signals between the aircraft and the DME site. Paired pulses at a specific spacing are sent out from the aircraft and are received by the ground station. The ground station then transmits paired pulses back to the aircraft at the same pulse spacing but on a different frequency. The time required for the round trip of this signal exchange is measured in the airborne DME unit and is translated into distance (NM) from the aircraft to the ground station. Distance information received from DME equipment is slant range distance and not actual horizontal distance. Accuracy of the DME system is within ± 0.5 NM or 3% of the distance, whichever is greater.

DME is normally collocated with VOR installations (VOR/DME) and may be collocated with an ILS or with localizers for LOC approaches. Where they can be justified, DME are also being collocated with NDBs to provide improved navigation

capability. For collocated sites, a single keyer is used to key both the VOR/ILS/localizer and the DME with the three-letter location indicator. The VOR/ILS/localizer transmits three consecutive indicator codes in a medium pitch of 1 020 Hz followed by a single DME indicator code transmitted on the DME frequency (UHF) and modulated at a slightly higher pitch of 1 350 Hz. In the event that one system should fail, the identification of the other will be transmitted continuously at approximately 7.5 second intervals. Independent DMEs and those collocated with NDBs normally have a two-letter or a letter-number indicator.

The DME system is in the UHF frequency band and therefore is limited to line of sight reception with a range similar to that of a VOR. The DME frequency is “paired” with VOR and localizer frequencies. As a result, the receiving equipment in most aircraft provide automatic DME selection through a coupled VOR/ILS receiver. Otherwise, the DME receiver must be selected to the “paired” VOR or localizer frequency. Distance information from a TACAN facility can be obtained by selecting the appropriate paired VOR frequency. (In that case, only DME information is being received, any apparent radial information must be ignored.) The DME paired frequency and channel number are published in the CFS and on the Enroute IFR charts in the navigation data box for all TACAN and DME installations.

By convention, those frequencies requiring only one decimal place (e.g., 110.3 MHz) are known as “X” channels and those associated with two decimal places are designated as “Y” channels (e.g., 112.45 MHz)

3.8 TACTICAL AIR NAVIGATION

Tactical Air Navigation (TACAN) is a NAVAID used primarily by the military for en route, non-precision approaches and other military applications. It provides azimuth in the form of radials, and slant distance in NM from the ground station. The system operates in the UHF range with the frequencies identified by channel number. There are 126 channels.

TACAN users may obtain distance information from a DME installation by selecting their receiver to the TACAN channel that is “paired” with the VOR frequency. This TACAN “paired” channel number is published in the CFS for every VOR/DME facility. (Pilots are cautioned, however, that only DME information is being received. Any apparent radial information obtained through a coupled VOR receiver can only be false signals.)

3.9 VHF OMNIDIRECTIONAL RANGE AND TACTICAL AIR NAVIGATION

A number of TACANs, supplied by DND, are collocated with VORs to form facilities called VORTACs.

This facility provides VOR azimuth, TACAN azimuth and slant distance from the site. Although it consists of more

than one component, incorporates more than one operating frequency, and uses more than one antenna system, a VORTAC is considered to be a single NAVAID. Components of a VORTAC operate simultaneously on “paired” frequencies so that aircraft DME receivers, when selected to the VOR frequency, will obtain distance information from the DME component of the TACAN. An aircraft must be equipped with a VOR receiver to use VOR, DME equipment to use DME, or TACAN equipment to use TACAN (azimuth and DME).

3.10 VHF DIRECTION FINDING EQUIPMENT

VHF direction finding (VDF) equipment is installed at a number of FSSs and airport control towers. VDF normally operates on six pre-selected frequencies in the 115 to 144 MHz range, which are listed in the CFS entry for aerodromes where the equipment is installed. Information displayed to the VDF operator (either an airport controller or a flight service specialist) on a numerical readout gives a visual indication of the bearing of an aircraft from the VDF site. This is based on the radio transmission received from the aircraft, thus giving the VDF operator a means of providing bearing or heading information to pilots requesting the service (see RAC 1.6).

3.11 LOCALIZER

A localizer without glide path guidance may be installed at some locations to provide positive track guidance during an approach. These aids may have a back-course associated with them. A cautionary note will be published on the approach plate whenever the localizer alignment exceeds 3° of the runway heading. No note will be published if the alignment is 3° or less.

Localizers operate in the 108.1 to 111.9 MHz frequency range and are identified by a three-letter indicator. Localizer alignment exceeding 3° of the runway heading will have an “X” as the first letter of the indicator, whereas localizers and back-courses with an alignment of 3° or less will have an “I” as the first letter.

The technical characteristics of this localizer are the same as described for the ILS localizer in COM 3.12.2.

3.12 ILS

At present, the ILS is the primary international non-visual precision approach system approved by ICAO.

The ILS is designed to provide an aircraft with a precision final approach with horizontal and vertical guidance to the runway. The ground equipment consists of a localizer, a glide path transmitter, as well as an NDB, a DME fix or an RNAV fix to denote the FAF. See Figure 3.2 for a typical ILS installation.

3.12.1 Caution—Use of ILS Localizers

- (a) *Localizer Coverage and Integrity:* The coverage and validity of ILS localizer signals are regularly confirmed by flight inspection within 35° of either side of a front- or back-course nominal approach path to a distance of 10 NM, and through 10° of either side of a front- or back-course nominal approach path to a distance of 18 NM (see Figure 3.1).
- (b) *Low Clearance Indications:* No problems with front and back courses have been observed within 6° of the course centreline. However, it has been found that failure of certain elements of the multi-element localizer antenna array systems can cause false courses or low clearances* beyond 6° from the front- or back-course centreline that are not detected by the localizer monitoring system. This could result in a premature cockpit indication of approaching or intercepting an on-course centreline. For this reason, a coupled approach should not be initiated until the aircraft is established within 6° of the localizer centreline. It is also essential to confirm the localizer on-course indication by reference to aircraft heading and other NAVAIDs (such as an ADF bearing or RNAV track) before commencing final descent. Any abnormal indications experienced within 35° of the published front- or back-course centreline of an ILS localizer should be reported immediately to the appropriate ATS facility.

*A low clearance occurs whenever there is less than full-scale deflection of the omnibearing selector or course deviation indicator (CDI) at a position where a full-scale deflection should be displayed outside of 6° from the localizer centerline.

- (c) *Localizer False Course:* False course captures may occur when the pilot prematurely selects APPROACH MODE from either heading (HDG) or lateral navigation (LNAV) MODE. Some ILS receivers produce lower than expected course deviation outputs in the presence of high modulation levels of the localizer radiated signal. This can occur even when both the ground transmitter and the airborne receiver meet their respective performance requirements. The reduced course deviation can, in turn, trigger a false course capture in the automatic flight control system (AFCS). False course captures can occur at azimuths anywhere from 6° to 35°, but are most likely to occur in the vicinity of 6° to 10° azimuth from the published localizer course. A false capture is deemed to have occurred when the automatic flight control guidance system (AFCS) allows the LOC to switch from ARMED to CAPTURED even though the omnibearing selector or CDI has not moved and is still at full-scale deflection.

In order to minimize the possibility of a false course capture during an ILS approach, pilots should use raw data sources to ensure that the aircraft is within 6° of the correct localizer course prior to initiating a coupled approach. The following cockpit procedures are recommended:

- (i) APPROACH MODE should not be selected until the aircraft is within 18 NM of the threshold and is positioned within 6° of the inbound ILS course; and
- (ii) pilots should:
- ensure that the ADF bearing (associated with the appropriate NDB site) or RNAV track for the runway is monitored for correct orientation;
 - be aware when the raw data indicates that the aircraft is approaching and established on the correct course; and
 - be aware that, should a false course capture occur, it will be necessary to deselect and re-arm APPROACH MODE in order to achieve a successful coupled approach on the correct localizer course.
- (d) *Electromagnetic Interference (EMI)*: The effect of EMI, particularly on ILS localizer system integrity, is becoming increasingly significant. In built-up areas, power transformer stations, industrial activity and broadcast transmitters have been known to generate interference that affects localizer receivers. The effect is difficult to quantify as the interference may be transitory, and certain localizer receivers are more susceptible than others to EMI. New ICAO standards for localizer and VOR receivers took effect on January 1, 1998. The increased immunity to FM broadcast interference may alleviate the situation once avionics are available. However, until new avionics are installed, operators may face increased interference and restricted operations in some areas, especially outside North America. In the interim, pilots must be aware, and compensating safety measures must be used. Unless the interference is of unusual intensity, or a very susceptible receiver is being used, the interference is not likely to cause any erroneous readings while the aircraft is flown within the area shown in Figure 3.1. If the localizer goes off the air, the “off” flag may remain out of sight or the flag and course deviation indicator may give erratic or erroneous indications. It is even possible that normal on-course cockpit indications may continue. Under normal circumstances, ATS will advise pilots conducting an approach if there is equipment failure.
- (e) *Automatic Landing (Autoland) Operations*: It has been common practice for operators of aircraft that are appropriately equipped and certified to conduct AFCGS autoland (CAT III) operations on CAT II/III facilities when weather conditions are above CAT I minima to satisfy maintenance, training or reliability program requirements. To achieve the necessary autoland rate, a portion of these autolands are also being conducted on runways that are approved for CAT I operations only.

The successful outcome of any AFCGS autoland depends on the performance of the aircraft’s AFCGS and the performance of the ILS localizer and glide path signals. The course structure and the integrity of an ILS can be compromised when protection of the ILS critical areas cannot be assured. The localizer is particularly sensitive due to its larger signal volume in the aerodrome

area. Surface and airborne traffic as well as stationary vehicles that are crossing or parked in these critical areas can create a deflection in, or a disturbance to, the ILS signal. The AFCGS will respond to this interference in a manner dependent upon the effect the interference has on the ILS signal characteristics and the control methods of the AFCGS. The following elements provide sufficient evidence that extreme caution must be exercised during these operations: observed AFCGS responses to ILS interference; reported aircraft lateral flight path deviations; aircraft pitch-up or pitch-down in response to traffic in front of the glide path antenna; and/or hard landings during autoland operations conducted on CAT II, CAT III, or CAT I ILS systems without the requisite low visibility procedures.

The commissioning, periodic flight inspection, and maintenance of the ILS facility serving a CAT I or CAT II runway include analysis of the ILS localizer performance past the runway threshold and along the runway to point echo (2000 ft from the rollout end of the runway). Glide path signal quality is inspected and calibrated to support the minima associated with the category of operation. CAT I and II ILS facilities have the signal characteristics to support AFCGS operations to CAT I and II minima, as applicable, but may not have the requisite signal characteristics to support autoland operations. Several CAT I facilities are known to exhibit very poor glide path signal qualities (below minima) in areas where it is assumed that the pilot would maintain visual reference and that these poor signal characteristics would therefore have no bearing on the approach facility’s status. NAV CANADA has posted graphs for localizer performance that are updated on an annual basis after inspections are completed. These graphs show the performance of the localizer along the approach and runway, with the protected critical areas, and are available from NAV CANADA Flight Operations.

The commissioning, periodic flight inspection, and maintenance of the ILS facility serving a CAT III runway include an analysis of the ILS localizer signal through the rollout to confirm that the ILS facility will support CAT III operations. However, this signal is protected by aerodrome and ATC only when low visibility procedures are in effect at that aerodrome. In general, the localizer critical area for CAT III operations extends along the runway, approximately 250 ft on either side of the runway centreline. CAT III critical area dimensions are based on the assumption that the entire longitudinal axis of any aircraft or vehicle is clear of this area.

Flight crews must recognize that changes in the ILS signal quality may occur rapidly and without warning from the ILS monitor equipment. Furthermore, flight crews are reminded to exercise extreme caution whenever ILS signals are used beyond the minima specified in the approach procedure and when conducting autolands on any category of ILS when the critical area protection is not

assured by ATC. Pilots must be prepared to immediately disconnect the autopilot and take appropriate action should unsatisfactory AFGS performance occur during these operations. (See AIR 2.15 for more information.)

- (f) *Glide Path False Course:* Glide path installations generate a radiated signal resulting in a normal glide path angle of 3° (it can currently be anywhere from 2.5° to 3.5° for an unrestricted ILS). The glide path angle is set to cross the runway thresholds at a nominal 50 ft. The normal antenna pattern of glide path installations generates a side-lobe. The side-lobe pattern produces a false glide path angle at two and three times the set angle (e.g. at 6° and 9° for a normal 3° glide path angle).

ATC procedures in terminal areas are designed to maintain aircraft at an altitude providing a normal rate of descent and a suitable position to capture the published glide path signal. Following the instrument procedures carefully will ensure an approach with a stable rate of descent and completely avoid the false glide path generated at two and three times the set angle. Failure to adhere to instrument procedures (e.g. remaining at a higher than published altitude) could result in positioning the aircraft in a false glide path radiated lobe.

In order to minimize the possibility of false glide path capture during an ILS approach, pilots should verify the rate of descent and the altitude at the FAF to ensure that the aircraft is on the published glide path.

3.12.2 Localizer

The localizer operates within the frequency range of 108.1 to 111.9 MHz and provides the pilot with course guidance to the runway centreline. When the localizer is used with the glide slope, it is called the “front course.” It is adjusted to provide an angular width between 3° and 6°. Normally, the width is 5°, which results in full deflection of the track bar at 2.5°. The transmitter antenna array is located at the far end of the runway from the approach. The localizer may be offset up to 3° from the runway heading and still publish as a straight-in procedure ; however, the amount of offset will be published as a cautionary note on the approach plate.

At a few aerodromes, a localizer “back course” is also provided. This allows for a non-precision approach in the opposite direction to a front course approach without glide path information. Note that not all ILS localizers radiate a usable back course signal.

The normal reliable coverage of ILS localizers is 18 NM within 10° of either side of the course centreline and 10 NM within 35° of the course centreline for both front and back courses.

Figure 3.1

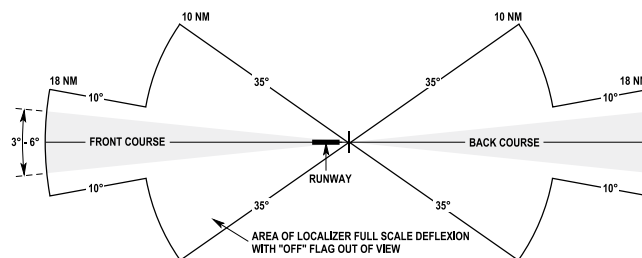

Identification for both the localizer and glide path is transmitted on the localizer frequency in the form of a two-letter or letter-number indicator preceded by the letter “I” (e.g. IOW).

3.12.3 Glide Path

The glide path transmitter operates within the frequency range of 329.3 to 335.0 MHz. The frequency is paired with the associated localizer frequency in accordance with ICAO standards. The glide path is normally adjusted to an approach angle of 3° and a beam width of 1.4°. There is no usable back course. The antenna array is located approximately 1 000 ft from the approach end of the runway and offset approximately 400 ft from the runway centreline. As the glide path is formed by reflecting the transmitted signal off the ground, the beam-forming area in front of the glide path antenna can be negatively affected by heavy snow buildup. Airports have snow-clearing plans in effect for this area as the snow must remain below the allowable design depth for proper glide path operation.

At some of the larger airports, an ILS is installed at each end of a runway. Consequently, a front course approach may be made to either end of the runway. The two systems are interlocked so that only one ILS can operate at any time.

Figure 3.2 – Typical ILS Installation

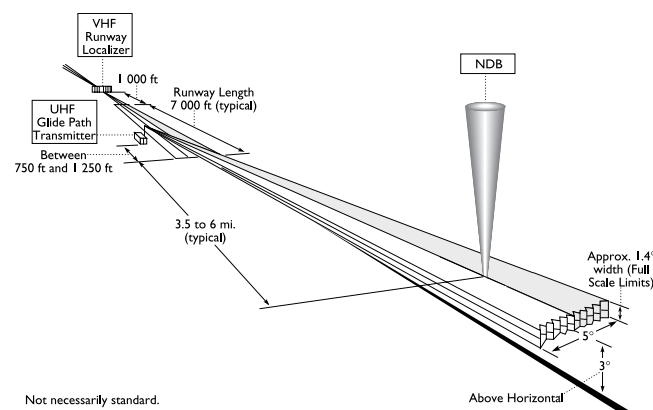

COM

3.12.4 NDBs

Low-powered NDB transmitters are sometimes located on the localizer (front and back course), 3.5 to 6 mi. from the runway threshold. If it is not possible to install an NDB, a DME fix or RNAV fix may be used instead to form the FAF. In a number of cases, an en-route NDB is located on a localizer so that it may serve as a terminal as well as an en-route facility. As a general rule, these NDBs transmit a two- or three-letter indicator. The FAF provides a fix to which the pilot can navigate for the transition to the ILS.

3.12.5 ILS/DME, ILS/RNAV

At some locations, it is not practicable to install an NDB because of terrain or costs. In such cases, DME provides distance information to define the IAF and MAP. In some locations, VOR/DME which are available either on the airport, or aligned with the appropriate runway, will be used to provide distance information for the transition to the ILS.

3.12.6 ILS Categories

- (a) *Operational CAT I:* Operation down to a minima of 200 ft DH and RVR 2 600 ft with a high probability of success. (When RVR is not available, 1/2 SM ground visibility is substituted.)
- (b) *Operational CAT II:* Operation down to a minima below 200 ft DH and RVR 2 600 ft, to as low as 100 ft DH and RVR 1 200 ft, with a high probability of success.
- (c) *Operational CAT III:* CAT III minima will be prescribed in the carrier's operating specifications, in the operator's operations manual, or in CAP.

3.12.7 CAT II/III ILS

CAT II/III ILS enable pilots to conduct instrument approaches to lower weather minima by using special equipment and procedures in the approaching aircraft and at the airport.

The following airport systems must be fully serviceable to meet CAT II/III standards:

- (a) *Airport Lighting:* a lighting system which includes:
 - approach lights
 - runway threshold lights
 - touchdown zone lights
 - centreline lights
 - runway edge lights
 - runway end lights
 - all stop bars and lead-on lights
 - essential taxiway lights
- (b) *ILS Components:* including:
 - localizer
 - glide path
 - NDB, DME or RNAV fix

(c) *RVR Equipment:* for CAT II operations, two RVRs: one located adjacent to the runway threshold (touchdown or RVR A), and one located adjacent to the runway mid-point (mid-point or RVR B). For CAT III operations, three RVRs: one located adjacent to the runway threshold (touchdown or RVR A), one located adjacent to the runway mid-point (mid-point or RVR B), and one located at the rollout end (rollout or RVR C) of the runway (ref. ICAO recommendation Annex III, para 4.7.2).

(d) *Power Source:* Airport emergency power (primary electrical source for all essential system elements), commercial power available within one second as backup.

The tower controller will determine the suitability for CAT II/III operations. Complete information regarding CAT II/III operations is found in the Manual of All Weather Operations (Categories II and III) (TP 1490E).

3.13 RADAR

The use of radar increases airspace utilization by allowing ATC to reduce separation between aircraft. In addition, radar permits an expansion of flight information services such as traffic information and navigation assistance. Radar is also used by AES meteorological staff for locating and defining storm areas and for tracking airborne equipment to determine upper winds, etc.

There are two types of radar systems currently in use: *Primary Surveillance Radar (PSR)* and *Secondary Surveillance Radar (SSR)*. PSR determines the position (range and azimuth) of contacts (aircraft and weather) by measuring and displaying reflected radio frequency signals from the contacts. It does not rely on information transmitted from the aircraft. SSR relies on measurement of the time interval between the interrogation and reply by an airborne transponder to determine aircraft range. The instantaneous direction of the antenna determines contact azimuth.

SSR will provide neither a position for aircraft without operating transponders, nor will it locate weather. However, SSR offers significant operational advantages to ATC, such as increased range, positive identification and aircraft altitude, when the aircraft has an altitude encoding transponder.

Radar is currently in use for the following functions:

(a) *En Route and Terminal Control:* SSR is the main source of en route (airways) information. Several locations have "stand alone" SSR. SSR is a long-range radar in the +200 NM range transmitting on 1030 MHz and receiving the transponder reply on 1090 MHz.

In general, SSR is complemented by the shorter range PSR for terminal operations. The radar types predominantly in use are:

- (i) *Terminal surveillance radar (TSR)*, which consists of:
 - *primary surveillance radar (PSR)*—a short-range

- radar (80 NM) operating on 1250 to 1350 MHz; and
- *secondary surveillance radar (SSR)*—a long-range radar (250 NM) transmitting on 1030 MHz and receiving airborne transponder replies on 1090 MHz.
- (ii) *Independent secondary surveillance radar (ISSR)*: a long-range radar (250 NM) transmitting on 1030 MHz and receiving airborne transponder replies on 1090 MHz.
- (b) *Precision Approach Radar (PAR)*: PAR is a high definition short-range PSR operating on 9000 to 9180 MHz, and is used as an approach aid. The system provides the controller with altitude, azimuth and range information of high accuracy to assist pilots in executing approaches. While basically a military system, PAR is available at some civilian airports and may be used by civilian pilots. Civil approach limits are published in CAP.
- (c) *Airport Surface Detection Equipment (ASDE)*: Radar surveillance of surface traffic is provided at certain airports where traffic warrants. This high-definition primary surveillance radar operating on 16 GHz is used by tower controllers to monitor the position of aircraft and vehicles on the manoeuvring areas of the airport (runways and taxiways) particularly during conditions of reduced visibility.
- (d) *Weather Radar*: Weather radar is a PSR used by EC to monitor for hazardous weather conditions.

3.14 AREA NAVIGATION

Area Navigation (RNAV) is a method of navigation which permits aircraft operation on any desired flight path within the coverage of station-referenced navigation aids or within the limits of the capability of self-contained navigation aids, or a combination of these.

Existing navigation systems which provide a RNAV capability include inertial navigation system (INS), VOR/DME (RHO-THETA), DME-DME (RHO-RHO) and GPS. Airspace management systems and procedures, and the future planning of ground based navigation aids, will focus on an area navigation concept to enable aircraft operators to exploit the benefits of RNAV. These benefits equal savings in operational costs resulting from more efficient routings.

Radio transmission based area navigation systems provide accurate positioning through the use of hyperbolic or direct-ranging techniques.

The hyperbolic mode of operation defines a line of position (LOP) by plotting points which have the same relative signal phase or time difference from two stations. The use of three stations will produce two LOPs, the intersection of which is the actual position of the receiver. The use of additional transmitting stations will normally provide better accuracy.

The advantages of this mode are: no requirement for a costly high precision time reference in the receiver, improved dynamic performance, long-term accuracy, and freedom from phase related errors.

The direct-ranging mode of operations defines the position by measuring the signal phase from two or more stations. A high precision oscillator reference is required in the aircraft receiver to provide acceptable accuracy when only two stations (RHO-RHO) are used. However, with three stations (RHO-RHO-RHO) the requirement for a precise oscillator reference is not as stringent because self-calibration of the low cost oscillator is possible.

RNAV systems may exhibit local inaccuracies as a result of propagation anomalies, errors in geodesy and non-programmed variations in signal timing. The effects of these variances may be substantially reduced by employing differential signal techniques. The differential facility is a precisely located receiver which continually monitors signals from the system and compares them with the expected signal at that location. If a difference is determined, a resulting correction factor is transmitted to users to upgrade the precision and performance of the receiver processor. The area over which corrections can be made from a single differential facility depends on a number of factors such as timeliness of the transmission of the correction factor, range of the correction signal, uniformity of the system grid and user receiver limitations.

3.14.1 VOR/DME (RHO-THETA) System

The capability of on-board RNAV computer systems which utilize VOR/DME signals varies considerably. The computer electronically offsets a VOR/DME station to any desired location within reception range. The relocated position is known as a way point and is defined by its bearing and distance from the station. Way points are used to define route segments and the computer provides steering guidance to and from way points.

3.14.2 DME-DME (RHO-RHO) System

DME-DME is a system which combines DME receivers with a microprocessor to provide an RNAV capability. The system has the location of the DME facilities in its data base. Measuring the distance from two or more of these stations can provide a positional fix. The system provides a means of entering way points for a random route and displays navigation information such as bearing, distance, cross-track error and time to go between two points.

3.14.3 LORAN-C System

On August 3, 2010 the United States Coast Guard and the Canadian Coast Guard terminated transmission of all LORAN-C signals. As a result, LORAN-C is no longer available for navigational use.

3.15 GLOBAL NAVIGATION SATELLITE SYSTEM (GNSS)

3.15.1 Satellite Navigation (SatNav)

The GNSS includes navigation satellites and ground systems that monitor satellite signals and provide corrections and integrity messages, where needed, to support specific phases of flight.

Currently, there are two navigation satellite systems in orbit: the U.S. GPS and the Russian global navigation satellite system (GLONASS). The U.S. and Russia have offered these systems as the basis for a GNSS, free of direct user charges. A third system, Galileo, is being developed by the European Union, with a planned initial operational capability in 2008, and is expected to support aviation use by 2010.

Only GNSS based on GPS is approved for aviation use; it is the cornerstone of SatNav in Canada. Transport Canada has authorized the use of GNSS under IFR in Canada for en-route, terminal and approach phases of flight. Terms and conditions of the domestic approval are found in AIC 16/08 and in a Special Notice in the CAP. Detailed information and guidance material is provided later in this section.

GNSS is also approved as a source of guidance in NAT MNPS airspace, as described in AIC 15/08.

GNSS supports RNAV, permitting aircraft operation on any desired flight path, thus allowing operators to choose fuel-efficient routes. GNSS also supports better instrument approaches at many airports, including vertical navigation when augmented, reducing delays and diversions. For these reasons, many Canadian aircraft operators have equipped with GNSS avionics.

3.15.2 Navigation Performance Requirements

Navigation systems used for IFR must meet international safety standards for accuracy, integrity, availability and continuity, which are key to safety and user acceptance. These terms are explained below:

Accuracy is the measure of position error, which is the difference between the estimated and the actual position.

Integrity is the measure of trust that can be placed in the correctness of the information supplied by the system. Integrity includes the system's ability to tell the user, in a timely fashion, when the system must not be used for the intended operation. The level of integrity required for each phase of flight is expressed in terms of horizontal (and in some cases, vertical) alert limits, as well as time-to-alarm.

Continuity is the system's capability (expressed as a probability) to perform its function throughout a specific operation. For example, there must be a high probability that the service remains available without interruption during a full instrument approach procedure.

Availability is the portion of time during which the system is able to deliver the required accuracy, integrity and continuity for a specific phase of flight.

3.15.3 Global Positioning System (GPS)

GPS was developed by the U.S. military, but since 1996, it has been managed by an executive board, chaired jointly by the departments of Defense and Transportation, that is comprised of representatives from several other departments to ensure that civil users' requirements are considered in the management of the system. A Presidential Statement was issued in December 2004 that made commitments to ensure the continued operation of the GPS constellation, with uninterrupted access to its signals, free of direct user charges.

The design GPS constellation contains 24 GPS satellites, orbiting the earth twice a day at an altitude of 10 900 NM (20 200 km). They are arranged in six separate orbital planes, with four satellites in each; this gives complete global coverage. In the past few years, there have actually been 26 to 28 operational satellites, but one or two can be out of service temporarily for orbital manoeuvres or maintenance.

All GPS orbits cross the equator at a 55° angle, so it is not possible to see a GPS satellite directly overhead north of 55° N or south of 55° S latitude. This does not affect service in polar areas adversely; in fact, on average, more satellites are visible at high latitudes since receivers can track satellites over the poles.

Each satellite transmits a unique coded signal, allowing identification by receivers, on two frequencies: 1575.42 (L1) and 1227.60 MHz (L2).

GPS provides a precise positioning service (PPS) and a standard positioning service (SPS). The PPS broadcast on L1 and L2 is encrypted and reserved for military applications. The SPS broadcast on L1 is for civil users.

GPS positioning is based on precise timing. Each satellite has four atomic clocks on board, guaranteeing an accuracy of one billionth of one second, and broadcasts a digital pseudorandom noise (PRN) code that is repeated every millisecond. All GPS receivers start generating the same code at the same time. Code matching techniques establish the time of arrival difference between the generation of the signal at the satellite and its arrival at the receiver. The speed of the signal is closely approximated by the speed of light, with variations resulting from ionospheric and atmospheric effects modeled or directly measured and applied. The time of arrival difference is converted to a distance, referred to as a pseudorange, by computing the product of the time of arrival difference and the average speed of the signal. The satellites also broadcast orbit information (ephemeris) to permit receivers to calculate the position of the satellites at any instant in time.

A receiver normally needs four pseudoranges to calculate a three-dimensional position and to resolve the time difference

between receiver and satellite clocks. In addition to position and time, GPS receivers can also calculate velocity—both speed and direction of motion.

GPS accuracy depends on transit time and signal propagation speed to compute pseudoranges. Therefore, accurate satellite clocks, broadcast orbits, and computation of delays as the signals pass through the ionosphere are critical. The ionosphere, which is a zone of charged particles several hundred kilometres above the earth, causes signal delays that vary from day to night and by solar activity. Current receivers contain a model of the nominal day/night delay, but this model does not account for variable solar activity. For applications requiring high accuracy, GPS needs space or ground-based augmentation systems (GBAS) to correct the computed transit time to compensate for this delay. These are discussed later.

Another key to GPS accuracy is the relative position of satellites in the sky, or satellite geometry. When satellites are widely spread, geometry and accuracy are better. If satellites are clustered in a small area of the sky, geometry and accuracy are worse. Currently, GPS horizontal and vertical positions are accurate to 6 m and 8 m, respectively, 95% of the time.

The GPS satellite constellation is operated by the U.S. Air Force from a control centre at Schriever Air Force Base in Colorado. A global network of monitor and uplink stations relays information about the satellites to the control centre and sends messages, when required, to the satellites.

If a problem is detected with a satellite, it is commanded to send an “unhealthy” status indication, causing receivers to drop it from the position solution. Since detection and resolution of a problem take time, and this delay is unacceptable in aviation operations, augmentation systems are used to provide the level of integrity required by aviation.

Current GNSS approvals require retention of traditional ground aids as a backup. Future approvals will emerge as GNSS evolves and can demonstrate that it meets availability requirements.

3.15.4 Augmentation Systems

Augmentation of GPS is required to meet the accuracy, integrity, continuity and availability requirements for aviation. There are currently three types of augmentation:

- (a) aircraft-based augmentation system (ABAS);
- (b) satellite-based augmentation system (SBAS); and
- (c) ground-based augmentation system (GBAS).

3.15.4.1 Aircraft-Based Augmentation System (ABAS)

The RAIM and fault detection and exclusion (FDE) functions in current IFR-certified avionics are considered ABAS.

RAIM can provide the integrity for the en-route, terminal, and non-precision approach phases of flight. FDE improves the continuity of operation in the event of a satellite failure and can support primary-means oceanic operations.

RAIM uses extra satellites in view to compare solutions and detect problems. It usually takes four satellites to compute a navigation solution, and a minimum of five for RAIM to function. The availability of RAIM is a function of the number of visible satellites and their geometry. It is complicated by the movement of satellites relative to a coverage area and temporary satellite outages resulting from scheduled maintenance or failures.

If the number of satellites in view and their geometry do not support the applicable alert limit (2 NM en route, 1 NM terminal and 0.3 NM non-precision approach), RAIM is unable to guarantee the integrity of the position solution. (Note that this does not imply a satellite malfunction.) In this case, the avionics RAIM function will alert the pilot, but will continue providing a navigation solution. Except in cases of emergency, pilots must discontinue using GNSS for navigation when such an alert occurs.

A second type of RAIM alert occurs when the avionics detects a satellite range error (typically caused by a satellite malfunction) that may cause an accuracy degradation that exceeds the alert limit for the current phase of flight. When this occurs, the avionics alerts the pilot and denies navigation guidance by displaying red flags on the HSI or course deviation indicator (CDI). Continued flight using GNSS is then not possible until the satellite is flagged as unhealthy by the control centre, or normal satellite operation is restored.

Some avionics go beyond basic RAIM by having an FDE feature that allows the avionics to detect which satellite is faulty, and then to exclude it from the navigation solution. FDE requires a minimum of six satellites with good geometry to function. It has the advantage of allowing continued navigation in the presence of a satellite malfunction.

Most first generation avionics do not have FDE and were designed when GPS had a feature called selective availability (SA) that deliberately degraded accuracy. SA has since been discontinued, and new generation (wide area augmentation system) WAAS-capable receivers (TSO C145a/C146a) account for SA being terminated. These receivers experience a higher RAIM availability, even in the absence of WAAS messages, and also have FDE capability.

For avionics that cannot take advantage of SA being discontinued, average RAIM availability is 99.99% for en-route and 99.7% for non-precision approach operations for a 24-satellite GPS constellation. FDE availability ranges from 99.8% for en-route to 89.5% for non-precision approach. Avionics that can take advantage of SA having been discontinued have virtually 100% availability of RAIM for en-route and 99.998% for non-precision approach; FDE

availability ranges from 99.92% for en-route to 99.1% for non-precision approach. These figures have been computed for mid-latitudes, and are dependent on user position and also on which satellites are operational at any given time. RAIM and FDE availability is typically even better at high latitudes, since the receiver is able to track satellites on the other side of the North Pole.

The level of RAIM or FDE availability for a certain airspace at a certain time is determined by an analysis of satellite geometry, rather than signal measurement. This is why it can be predicted by receivers or with PC-based computer software. The difference between the two methods is that the receivers use the current constellation in their calculations while the PC software can use a constellation definition that takes into account scheduled satellite outages.

Most TSO C129a avionics also accept signals from an aircraft altitude encoder. This is called baro-aiding, and it essentially reduces the number of satellites required by one, thus further increasing the availability of RAIM and providing an additional measure of tolerance to satellite failures. Operators contemplating the installation of SatNav receivers are encouraged to incorporate a baro encoder input to the receiver wherever possible.

With proper integration, IRS can augment/enhance GNSS navigation. This system allows “coasting” through periods of low availability. IRS is costly; therefore, it is usually found in commercial airline and sophisticated business aircraft. A low cost IRS-like alternative for aviation, using solid-state sensors, is starting to emerge, but none is currently approved in Canada.

3.15.4.2 Satellite-Based Augmentation System (SBAS)

SBAS uses a network of ground-based reference stations that monitor navigation satellite signals and relay data to master stations, which assess signal validity and compute error corrections. The master stations generate two primary types of messages: integrity, and range corrections. These are broadcast to users via geostationary earth orbit (GEO) satellites (hence SBAS) in fixed orbital positions over the equator. The SBAS GEO satellites also serve as additional sources of navigation ranging signals.

The integrity messages provide a direct validation of each navigation satellite’s signal. This function is similar to RAIM, except that the additional satellites required for RAIM are not necessary when SBAS integrity messages are used. The integrity messages are available wherever the GEO satellite signal can be received.

The range corrections contain estimates of the errors introduced into the range measurements as a result of ionospheric delays, and satellite ephemeris (orbit) and clock errors. Ionospheric delay terms are critical for correction messages, and are also the most challenging to characterize. First, each reference station measures the ionospheric delay

for each visible satellite. These observations are sent to the master station, where they are combined, and used to generate a model of the ionosphere, which is then transmitted to the receivers via the GEO satellite. The accuracy of the model is dependent on the number and placement of the reference stations providing observations of ionospheric delays.

By compensating for these errors, SBAS receivers can compute the position of the aircraft with the accuracy necessary to support advanced flight operations with vertical guidance. SBAS can provide lateral accuracy similar to a localizer, and vertical performance somewhat better than barometric vertical navigation (BARO VNAV), but without the need for temperature correction or a local field altimeter setting.

Unlike BARO VNAV, SBAS vertical guidance is not subject to altimeter setting errors, or non-standard temperatures or lapse rates. Vertical guidance provides safer stabilized approaches and transition to visual for landing. This represents one of the principal benefits from SBAS service. The other is lower approach minima at many airports, as a result of greater lateral accuracy. SBAS has the potential to meet CAT I approach standards with the next generation of GPS satellites.

The first SBAS, the U.S. FAA’s WAAS, was commissioned in 2003. Europe, Japan and India are also building compatible systems to augment GPS [EGNOS (European Geostationary Navigation Overlay Service), MSAS (Multi-functional Transport Satellite (MTSAT) Satellite-Based Augmentation System) and GAGAN (GPS and GEO Augmented Navigation), respectively].

The use of WAAS receivers for en-route, terminal, and non-precision approach (RNAV and overlay) operations has been permitted in Canada since January 2003. Vertical guidance provided by WAAS receivers is now authorized for RNAV approaches.

WAAS currently uses two GEO satellites located over the Atlantic and Pacific Oceans.

This gives integrity message coverage over most of Canada south of 70° latitude, and increases the availability of non-precision approach to virtually 100%.

There is a program underway to deploy additional GEO satellites to provide redundant WAAS coverage over all but the extreme north of Canada.

The coverage of WAAS vertical guidance is also dependent on the location of the reference stations. There must be a sufficient number of ionospheric delay measurements to model the ionosphere accurately to determine its effect at a receiver’s position.

Currently, all the reference stations are located in the conterminous United States and Alaska. Consequently, WAAS service that supports vertical guidance is now available in

most of the Yukon Territory, the western half of the Northwest Territories, British Columbia, Alberta, Saskatchewan, the southern half of Ontario, and the portion of Quebec south of a line running from Rouyn-Noranda to Québec City.

NAV CANADA is currently working to extend WAAS vertical service throughout much of Canada by establishing reference stations in Canada and linking them to the FAA WAAS network. It is anticipated that this will result in the expansion of WAAS vertical guidance capability to the southern half of Quebec, all of Nova Scotia, New Brunswick and Prince Edward Island, and the western portion of Newfoundland by late 2006. Another expansion phase during 2007 will result in these services being available to all of Ontario, Quebec, Labrador, and most of Newfoundland.

3.15.4.3 Ground-Based Augmentation System (GBAS)

Another augmentation system being developed is GBAS, or the local-area augmentation system (LAAS). It is called GBAS because corrections are sent directly to user receivers from a ground station at an airport.

GPS receivers with antennas at surveyed locations provide measurements used to generate and broadcast pseudorange corrections. Aircraft receivers use the corrections for increased accuracy, while a monitor function in the ground station assures the integrity of the broadcast. GBAS provides service over a limited area, typically within 30 NM of the ground station.

The goal of GBAS is to support all precision approach categories and, possibly, surface movement guidance. There are still a number of technical challenges to overcome, and it is not clear when GBAS will be available in Canada.

3.15.5 IFR Approval to Use GNSS and WAAS in Domestic Airspace

Pilots in Canada can use GNSS (GPS, or GPS augmented by WAAS), to fly IFR in the en-route, terminal and non-precision approach phases of flight.

Approach procedures with vertical guidance (APV) classified as LPV (localizer performance with vertical guidance) and lateral navigation / vertical navigation (LNAV/VNAV) approaches may be flown using WAAS.

Suitably-equipped aircraft may fly LNAV/VNAV approaches using GNSS to provide lateral navigation and BARO VNAV for the vertical.

The following table lists the capability required for each phase of flight:

Phase Of Flight	SatNav Capability
En-route	GPS or WAAS
Terminal	GPS or WAAS
Non-precision approach (LNAV)	GPS or WAAS
LNAV/VNAV	WAAS (for lateral and vertical)
LNAV/VNAV	GPS or WAAS lateral BARO VNAV vertical
LPV	WAAS (for lateral and vertical)

SatNav capability may be provided by a panel-mount GPS or WAAS receiver, or an FMS that uses a GPS or WAAS sensor.

Avionics have to meet appropriate equipment standards, which are listed in the CAP Special Notice and AIC 16/08, and referenced throughout this document.

Equally important, the avionics installation must be approved by Transport Canada to ensure proper avionics integration and display.

Hand-held and other VFR receivers do not support integrity monitoring, nor do they comply with other certification requirements; therefore, they cannot be used for IFR operations.

Holders of air operator certificates (AOC) issued under Part VII of the CARs, and private operator certificates issued under Subpart 604 of the CARs, are required to be authorized by an operations specification to conduct GNSS instrument approach operations in IMC. This is explained in Commercial and Business Aviation Advisory Circular (CBAAC) 0123R, dated 25 March 2004.

3.15.5.1 Domestic En-Route and Terminal Operations

GNSS may be used for all en-route and terminal operations, including navigation along airways and air routes, navigation to and from ground-based aids along specific tracks, and RNAV. In accordance with the approval described in the CAP Special Notice, the aircraft must also carry approved traditional systems, such as VOR and ADF, to serve as a backup when there are not enough GPS satellites in view to support RAIM. Certain GNSS avionics systems can also meet long-range navigation requirements for flight in CMNPSA and RNP-C airspace. For more information on MNPS, RNP-C and CMNPS certification, contact the Transport Canada Regional Manager, Commercial and Business Aviation.

In practice, pilots can use GNSS for guidance most of the time. If an integrity alert occurs while en route, the pilot can then continue by using traditional aids, diverting if necessary from the direct routing, notifying ATS of any changes to the flight and obtaining a new clearance, as required.

COM

When using GNSS to maintain a track in terminal operations, the avionics shall be in terminal mode and/or the course deviation indicator (CDI) shall be set to terminal sensitivity. (Most avionics set the mode and sensitivity automatically within 30 NM of the destination airport, or when an arrival procedure is loaded.)

When using GNSS to navigate along airways, VOR or ADF reception is not an issue. This means that pilots using GNSS for navigation can file or request an altitude below the MEA, but at or above the MOCA, to avoid icing, optimize cruise altitude, or in an emergency. However, an ATS clearance to fly at a below-MEA altitude could be dependent on issues such as traffic communications reception and the base of controlled airspace. In the rare case of a RAIM alert while en route below the MEA, and out of range of the airway navigation aid, pilots should advise ATS and climb to continue the flight using VOR or ADF.

GNSS avionics typically display the distance to the next waypoint. To ensure proper separation between aircraft, a controller may request the distance from a waypoint that is not the currently-active waypoint in the avionics; it may even be behind the aircraft. Pilots must be able to obtain this information quickly from the avionics. Techniques vary by manufacturer, so pilots should ensure familiarity with this function.

At times outside radar coverage, pilots may be cleared by ATS to a position defined by a latitude and longitude. As these are usually outside the range of traditional navigation aids, there is no means to cross check that the coordinates have been entered accurately. Pilots must be particularly careful to verify that the coordinates are correct.

3.15.5.2 GNSS-Based RNAV Approach Procedures

Prior to the advent of GNSS, ICAO defined only two approach and landing operations: precision approach (PA) and non-precision approach (NPA). It has now added definitions for approach and landing operations with vertical guidance (APV) to cover approaches that use lateral and vertical guidance, but that do not meet the requirements established for precision approach.

GNSS-based approaches are charted as “RNAV (GPS) RWY XX” or “RNAV (GNSS) RWY XX.” The “(GPS)” before the runway identification indicates that GNSS must be used for guidance. Pilots and controllers shall use the prefix “RNAV” in radio communications (e.g. “cleared the RNAV RWY 04 approach”).

GNSS-based RNAV approaches are designed to take full advantage of GNSS capabilities. A series of waypoints in a “T” or “Y” pattern eliminates the need for a procedure turn. The accuracy of GNSS often means lower minima and increased capacity at the airport. Because GNSS is not dependent on the location of a ground-based aid, straight-in approaches are possible for most runway ends at an airport.

GNSS-based RNAV approaches are often provided for runways that have no traditional approach, runways that are served only by circling approaches, or runways that have traditional approaches, but where a GNSS-based approach would provide an operational advantage. At this time, over 350 public RNAV (GPS) approaches are published in the CAP. This number will continually increase because the great majority of new approaches designed in Canada are RNAV (GPS) or RNAV (GNSS) approaches.

RNAV (GPS) and RNAV (GNSS) approach charts will, in many cases, depict three sets of minima:

- LPV (localizer performance with vertical guidance—APV)
- LNAV/VNAV (lateral/vertical navigation—APV); and
- LNAV (lateral navigation only—NPA);

The airborne equipment required to fly to the various minima is described in later sections.

The LNAV minima indicate a non-precision approach, while the LNAV/VNAV and LPV minima refer to APV approaches (RNAV approaches with vertical guidance). However, the actual terms “NPA” and “APV” do not appear on the charts because they are approach categories not related to specific procedure design criteria. The depiction of the three sets of minima is analogous to the way that an ILS approach may show landing minima for ILS, localizer (LOC) and CIRCLING.

The approach chart may indicate a WAAS channel number. This is used for certain types of avionics, and permits the approach to be loaded by entering the number shown.

All approaches must be retrieved from the avionics database, and that database must be current. While it is sometimes acceptable to use pilot-generated waypoints en route, it is not permitted for approach procedures, as any database or waypoint coordinate errors could have serious consequences.

Because flying GNSS-based approaches requires good familiarity with the avionics, it is recommended that pilots make use of PC-based simulation features available from most manufacturers (often via the Internet). Several approaches should first be flown VFR to build confidence and familiarity before attempting operations in IMC. Of particular concern is the missed approach procedure, where some older avionics may require several pilot actions.

3.15.5.2.1 RNAV Approaches with Lateral Guidance Only

RNAV (GPS) LNAV approaches do not define a vertical path through space; as such, each approach segment has a minimum step-down altitude below which the pilot may not descend. These are normally flown using the “level-descend-level” method familiar to most pilots.

GPS (TSO C129/C129a Class A1, B1, B3, C1 or C3) and WAAS (TSO C145a/C146a, any class) avionics are both able to provide the lateral guidance required for these approaches.

Without vertical guidance, pilots fly to the LNAV MDA line depicted on the plate. The pilot is required to remain at or above the MDA unless a visual transition to landing can be accomplished, or to conduct a missed approach at the missed approach waypoint (MAWP), typically located over the runway threshold.

WAAS and some TSO C129/C129a avionics may provide advisory vertical guidance when flying approaches without LNAV/VNAV or LPV minima. It is important to recognize that this guidance is advisory only and the pilot is responsible for respecting the minimum altitude for each segment until a visual transition to land is commenced.

Pilots using TSO C129/C129a avionics should use the RAIM prediction feature to ensure that approach-level RAIM will be supported at the destination or alternate airport for the ETA (± 15 min). This should be done before takeoff, and again prior to commencing a GNSS-based approach. If approach-level RAIM is not expected to be available, pilots should advise ATS as soon as practicable and state their intentions (e.g. delay the approach, fly another type of approach, proceed to alternate).

3.15.5.2.2 GPS Overlay Approaches

GPS overlay approaches are traditional VOR- or NDB-based approaches that have been approved to be flown using the guidance of IFR approach-certified GNSS avionics. Because of approach design criteria, LOC-based approaches cannot be overlaid.

GPS overlay approaches are identified in the CAP by including “(GPS)” in small capitals after the runway designation [e.g. NDB RWY 04 (GPS)]. When using GNSS guidance, the pilot benefits from improved accuracy and situational awareness through a moving map display (if available) and distance-to-go indication. In many cases, the pilot can bypass the procedure turn and fly directly to the FAF for a more efficient approach, as long as minimum sector altitudes are respected. Unless required by the aircraft flight manual (AFM) or AFM Supplement, it is not necessary to monitor the underlying navigation aid, and it is even permissible to fly a GPS overlay approach when the underlying navigation aid is temporarily out of service. Nevertheless, good airmanship dictates that all available sources of information be monitored.

Pilots shall request GPS overlays as follows: “request GPS overlay RWY XX.” ATS may ask the pilot to specify the underlying navigation aid if more than one overlay approach is published for the runway.

GPS overlay approaches were intended to be a transition measure to allow immediate benefits while waiting for the commissioning of a GNSS stand-alone approach for a runway. For this reason, in most cases, the GPS overlay approach

will be discontinued when a GNSS stand-alone approach is published for a given runway. There are still over 120 GPS overlay approaches published in the CAP.

When flying overlay approaches, pilots should use the RAIM prediction feature of TSO C129/C129a avionics to ensure that approach-level RAIM will be supported, as described in the preceding section.

3.15.5.2.3 Vertical Guidance on RNAV Approaches

LNAV/VNAV and LPV describe approaches with vertical guidance. These will deliver the safety benefits of a stabilized approach and, in many cases, will improve airport accessibility. However, as with any advance in aviation, pilots must appreciate the relevant requirements and limitations.

Aircraft with TSO C145a/C146a (WAAS Class 2 or 3) or TSO C115b (multi-sensor FMS) avionics, may fly RNAV (GPS) and RNAV (GNSS) approaches to LNAV/VNAV minima with vertical guidance in a similar manner to the way they fly an ILS approach: with both a lateral course deviation indicator (CDI) and a vertical deviation indicator (VDI). The lateral guidance must be based on GPS or WAAS. The vertical guidance may be based on WAAS, or on barometric inputs (BARO VNAV), depending on the approach and the aircraft equipage.

Aircraft with WAAS Class 3 avionics may fly RNAV (GNSS) approaches to LPV minima in a similar manner. In this case, both the lateral and vertical guidance are based on WAAS.

The nominal final approach course vertical flight path angle for LNAV/VNAV and LPV approaches is 3°, avoiding the step-down minimum altitudes associated with traditional non-precision approaches.

The LNAV/VNAV and LPV minima depict a decision altitude (DA), which requires the pilot to initiate a missed approach at the DA if the visual reference to continue the approach has not been established. In most cases, the DA associated with LNAV/VNAV or LPV approaches will be lower than the LNAV MDA, since the LNAV/VNAV and LPV approach designs use a sloped vertical obstacle clearance surface.

3.15.5.2.4 RNAV Approaches with Vertical Guidance Based on BARO VNAV

Multi-sensor FMSs meeting TSO C115b have been certified since the late eighties to provide guidance for a stabilized final approach segment while flying non-precision approaches. The vertical guidance for these systems has been derived from a barometric altitude input; hence, these approaches are known as BARO VNAV approaches. This equipment has typically only been installed on transport category airplanes. The information provided by these systems is advisory only, and pilots are required to respect all minimum altitudes, including step-down altitudes, since non-precision approaches are not specifically designed to take advantage of BARO VNAV capability.

With the publication in Canada of RNAV (GNSS) approaches with vertical guidance, suitably-equipped aircraft may fly BARO VNAV approaches to the LNAV/VNAV minima published on these approach plates. The standard for equipment is a multi-sensor FMS meeting TSO C115b and certified in accordance with FAA Advisory Circular (AC) 20-129, or equivalent. The FMS must use GNSS sensor input, but does not require a WAAS-capable receiver to fly to LNAV/VNAV minima.

Pilots must note that the vertical path defined by BARO VNAV is affected by altimeter setting errors. For this reason, BARO VNAV is not authorized unless a local field altimeter setting is available.

Non-standard atmospheric conditions, particularly temperature, also induce errors in the BARO VNAV vertical path. For example, a nominal 3° glide path may be closer to 2.5° at very low temperatures. Similarly, at above ISA temperatures, a BARO VNAV vertical path would be steeper than normal. To compensate for these temperature effects, some avionics allow input of the temperature at the airport, and apply temperature compensation so that the BARO VNAV vertical path is not biased as a function of temperature. Unfortunately, not all systems have the capability to compensate for temperature effects.

The sample vertical path angle (VPA) deviation chart, below, indicates the effect of temperature on the uncorrected BARO VNAV VPA, for an aerodrome at sea level.

VPA Deviations	
Aerodrome Temp.	Uncorrected VPA
+30°C	3.2°
+15°C	3.0°
0°C	2.8°
-15°C	2.7°
-31°C	2.5°

When temperature compensation is not, or cannot be, applied through the FMS, pilots shall refer to a temperature limit, referred to as T_{lim} , published on the approach chart. Below this temperature, the approach is not authorized using BARO VNAV guidance. T_{lim} will be a function of the reduced obstacle clearance resulting from flying an uncompensated VPA, and will vary from approach to approach. For avionics systems that have the capability to correctly compensate the VPA for temperature deviations, the published T_{lim} does not apply if the pilots enable the temperature compensation.

Regardless of whether the FMS provides temperature compensation of the vertical path or not, all altitudes on the approach, including DA, should still be temperature-corrected (by FMS temperature compensation or per the Altitude Correction Chart in the CAP GEN section and TC AIM RAC Section 9.17.1, Figure 9.1).

3.15.5.2.5 RNAV Approaches with Vertical Guidance Based on WAAS

RNAV (GNSS) approaches with vertical guidance based on WAAS require a Class 2 or 3 (for LNAV/VNAV minima) or Class 3 (for LPV minima) TSO C145a WAAS receiver, or a TSO C146a sensor interfaced to appropriate avionics.

RNAV (GNSS) approaches with vertical guidance based on WAAS are entirely dependent on the WAAS signal. WAAS meets essentially the same navigation performance requirements (accuracy, integrity and continuity) as ILS, and pilots can expect that guidance will be similar to that provided by an ILS, with some improvement in signal stability over ILS. The LPV approach design criteria are similar to ILS CAT I, although the lowest currently-attainable DA will be 250 ft HAT.

WAAS avionics continuously calculate integrity levels during an approach and will provide a message to the crew if alert limits are exceeded, analogous to ILS monitors that shut down an ILS signal when its accuracy does not meet the required tolerances.

Although the WAAS integrity monitor is very reliable, good airmanship nevertheless dictates that pilots verify the final approach waypoint (FAWP) crossing altitude depicted on approach plates with LNAV/VNAV and LPV minima, in the same way that the beacon crossing altitude is checked when flying an ILS approach. Large altitude deviations could be an indication of a database error or otherwise undetectable incorrect signal.

3.15.6 Flight Planning

NOTAM on ground-based navigation aid outages are of direct use to pilots because if a navigation aid is not functioning, the related service is not available. With GPS and WAAS, the knowledge of a satellite outage does not equate to a direct knowledge of service availability. The procedures for determining service availability are different for GPS (TSO C129/C129a) and WAAS (TSO C145a/C146a) avionics, and are explained in the next sections.

3.15.6.1 GPS NOTAM

This section is applicable only to operators using TSO C129/C129a avionics.

Research has shown minor differences among avionics' computations of RAIM availability, making it impractical to develop a GPS RAIM NOTAM system that will work reliably for all receivers. Because of this, and since the IFR GPS approval requires aircraft to be equipped with traditional avionics to be used when RAIM is unavailable, NOTAM information on GPS RAIM availability is not provided in Canada.

Canadian flight information centres (FIC) can supply NOTAM on GPS satellite outages by querying the international NOTAM identifier KNMH. (This information is also available at <https://www.notams.jcs.mil>.) The availability of RAIM can then be computed from the satellite availability information by entering the expected outages into PC-based RAIM prediction software provided by some avionics manufacturers or through direct entry into FMS computers that support this function.

GNSS avionics also contain such a model, and this allows pilots to determine if approach-level RAIM will be supported (available) upon arrival at destination or an alternate. The calculation typically uses current information, broadcast by the satellites, identifying which satellites are in service at that time. However, unlike the software that is based on the NOTAM data, this prediction does not take into account scheduled satellite outages.

Operators using TSO C129/C129a avionics who wish to take advantage of an RNAV (GPS) or RNAV (GNSS) approach when specifying an alternate airport must check KNMH NOTAM to verify the status of the constellation, as described in Section 3.15.12.

3.15.6.2 WAAS NOTAM

NAV CANADA has implemented a NOTAM system for users of WAAS avionics (TSO C145a/C146a). It makes use of a service volume model (SVM) that considers current and anticipated GPS constellation status and geometry, and the availability of WAAS GEO satellites, and computes estimates of the availability of service where SatNav-based approach procedures are published.

The SVM runs twice daily, at 0000Z and 1200Z. It computes the expected availability of LPV, and WAAS-based LNAV/VNAV and LNAV for a period of eighteen hours for all aerodromes in its database. When a service is predicted not to be available for a duration of more than fifteen minutes, an aerodrome NOTAM will be issued. In the event that two outages of less than fifteen minutes each are predicted, and are separated by a period of less than fifteen minutes during which the service is available, a NOTAM will be issued for a single outage covering the entire period.

The SVM is also run in response to an unscheduled change in the GPS constellation status. This typically implies a satellite failure.

Pilots should flight plan based on the assumption that the services referred to in a NOTAM will not be available. However, once they arrive at the aerodrome, they may discover that a service is, in fact, available because of the conservative nature of the prediction, in which case they may use the approach safely if they so choose.

When LPV and WAAS-based LNAV/VNAV are not available, pilots may fly the LNAV procedure to the published MDA; this will almost always be available to pilots using WAAS avionics. Since LNAV procedures will be used when LPV and LNAV/VNAV is not available, pilots should ensure that they maintain their skills in flying these approaches.

Because of the high availability of services supporting en-route and terminal operations, no NOTAMs are issued for these phases of flight.

Some examples of WAAS NOTAMs are listed below:

- (a) LPV NOT AVBL 0511211200 TIL 0511211240. This is issued as an aerodrome NOTAM, and indicates that the SVM has predicted that LPV service may not be available for the specified period.
- (b) LPV AND WAAS-BASED LNAV/VNAV NOT AVBL 0511211205 TIL 0511211235. This aerodrome NOTAM indicates that LPV and LNAV/VNAV based on WAAS is expected to be unavailable for the specified period. This will be the most common type of WAAS NOTAM. Note that if LNAV is available, the LNAV/VNAV approach may be flown by aircraft equipped for BARO VNAV.
- (c) WAAS-BASED LNAV NOT AVBL 0511211210 TIL 0511211225. This is an aerodrome NOTAM that indicates that the SVM has predicted that LNAV service may not be available for the specified period.
- (d) LPV AND WAAS-BASED LNAV/VNAV NOT AVBL WEST OF LINE FM WHITEHORSE TO CALGARY 0511011800 TIL APRX 0511071800. This will be issued as an FIR NOTAM, and is used to communicate that a GEO satellite failure has occurred, disrupting all WAAS messages for the area covered by that satellite.
- (e) LPV AND WAAS-BASED LNAV/VNAV NOT AVBL 0511200800 TIL APRX 0511241600. When issued as a national (CYHQ) NOTAM, this indicates the complete loss of WAAS services. Note that LNAV will still likely be available for operators using WAAS avionics; NOTAM for LNAV outages will be issued for each affected aerodrome, as described in (c) above.
- (f) WAAS UNMONITORED 0511302100 TIL APRX 0512011200. This national NOTAM is used to indicate a failure in the WAAS NOTAM system itself. Since pilots would not be alerted to disruptions of WAAS services, flight planning should be based on the assumption that LPV and WAAS-based LNAV/VNAV may be unavailable.

Note that WAAS NOTAM information is not applicable to users of TSO C129a avionics.

3.15.6.3 Negative W Notation

Normally, WAAS-based approaches will only be designed and published where the nominal availability of the required service is greater than 99%. This policy avoids issuing a large number of NOTAM for sites where the availability is low.

However, there may be aerodromes for which an LNAV/VNAV approach is published because of a local demand by operators flying BARO VNAV-equipped aircraft. These procedures will appear in the database of WAAS receivers, and will be flyable by them. In the event that such an aerodrome is located in a region of poor WAAS availability, NOTAMs will not be issued when WAAS-based LNAV/VNAV is expected to be unavailable. Pilots will be alerted to this fact by a negative “W” (white on a black background) on the approach plate.

Pilots should flight plan as though WAAS-based LNAV/VNAV will not be available at these aerodromes; however, if the service is available, it may be used safely at the pilot’s discretion.

3.15.7 Flight Plan Equipment Suffixes

The letter “G” in item 10 of the IFR flight plan (equipment) indicates that the aircraft has IFR-approved GPS or WAAS avionics, and can therefore be cleared by ATS on direct routings while en route, in terminal areas, and for GNSS-based approaches. It is the pilot’s responsibility to ensure that the relevant equipage requirements are met for GNSS-based approaches.

Pilots using GPS or WAAS, including hand-held units, who are filing VFR flight plans are also encouraged to use the “G” notation to convey their ability to follow direct routings. This does not imply a requirement for IFR-approved avionics.

3.15.8 Avionics Databases

GNSS avionics used for IFR flight require an electronic database that can be updated, normally on 28- or 56-day cycles. The updating service is usually purchased under subscription from avionics manufacturers or database suppliers.

Database errors do occur, and should be reported to the avionics database supplier. Jeppesen accepts e-mailed database reports at <navdatatechsupport@jeppesen.com>. It is good practice to verify that retrieved data is correct, and it is mandatory to do so for approach data. Verification can be accomplished either by checking waypoint co-ordinates or by checking bearings and distances between waypoints against charts.

3.15.9 Use of GNSS in Lieu of Ground-based Aids

Subject to any overriding conditions or limitations in the aircraft flight manual (AFM) or AFM Supplement, GNSS may be used to identify all fixes defined by DME, VOR, VOR/DME and NDB, including fixes that are part of any

instrument approach procedure, to navigate to and from these fixes along specific tracks, including arcs, and to report distances along airways or tracks for separation purposes. This can be done as long as there is no integrity alert, and provided that all fixes that are part of a terminal instrument procedure (arrival, departure, or approach) are named, charted and retrieved from a current navigation database. GNSS may be used to identify fixes defined by ground-based aids, even if they are temporarily out of service.

For example, if the DME associated with an ILS/DME approach is unserviceable, traditional aircraft would be denied the approach; however, under these rules, the pilot of a GNSS-equipped aircraft may request and fly the approach.

Note that for NDB or VOR approaches that are not part of the GPS overlay program described in Section 3.15.5.2.2, pilots shall use ADF or VOR as the primary source for final approach track guidance. For these approaches, and for approaches based on a localizer (LOC) for lateral guidance, pilots shall not use GNSS as the primary source for missed approach guidance when the missed approach procedure requires flying a published track to or from an NDB or VOR. Where ATS requests a position based on a distance from a DME facility for separation purposes, the pilot should report GPS distance from the same DME facility, stating the distance in “miles” and the facility name (e.g. “30 miles from Sumspot VOR”). This phraseology is used for all RNAV systems. When reporting DME distance, the pilot includes “DME” in the report (e.g. “30 DME from Sumspot VOR”). This enables ATS to allow for the DME slant range.

Note that under this approval, there is no requirement to carry the avionics normally used to identify fixes defined by ground-based aids, but other considerations may apply. This topic is discussed in Section 3.15.10.

3.15.10 Replacement of DME or ADF by GNSS Avionics

Before making a decision on avionics equipment, aircraft operators should take GNSS performance and their operational environment into consideration. Some analysis is required to determine how CAR 605.18(j) relates to a specific operation. The following paragraphs highlight some of the factors that should be considered.

In the settled areas of southern Canada, aerodromes are relatively plentiful and a variety of navigation aids is typically available. In these areas, operators equipped with GNSS avionics meeting the conditions of approval described in the CAP Special Notice may consider eliminating DME and perhaps ADF avionics. Such a decision should be based on a thorough analysis of the navigation aids available in the normal area of operations, the availability of GNSS approaches, and the availability of alternate aerodromes. The decision should also be made within the context of the regulatory requirements described above. Operators should

also remember that the availability of RAIM or WAAS integrity depends on the phase of flight and on the number of satellites in view at any given time.

In sparsely settled areas, particularly in the Arctic, aerodromes are farther apart and the most common navigation aid is the NDB. In these areas, operators equipped with GNSS avionics meeting the conditions in this document may consider eliminating DME avionics, but would likely not meet the CAR 605.18 requirements without ADF. On the other hand, with either a GNSS stand-alone or GPS overlay approach available at virtually all aerodromes, a single ADF would likely meet the requirements. Generally, approach-level RAIM availability should be highest in northern Canada because satellites over the other side of the North Pole are visible to receivers at high latitudes.

3.15.11 NAT MNPS Operations

In the NAT, a single GPS/RAIM unit can be used to replace one of the two required long range navigation systems, as specified in AIC 15/08. In this case, inertial reference systems can be used if RAIM is lost.

Alternatively, as described in AIC 15/08, a dual GPS/FDE (global positioning system / fault detection and exclusion) installation, including TSO C145a/C146a avionics, can meet requirements, provided that operators complete a software-based pre-flight RAIM/FDE prediction to ensure service will be available for the Atlantic crossing. On very rare occasions, operators may have to delay a flight based on the RAIM/FDE prediction.

3.15.12 GPS and WAAS Approaches at Alternate Aerodromes

Risk assessment of GNSS performance has made it possible to relax the restriction that prohibited taking credit for GNSS-based approaches when selecting alternate aerodromes for flight planning purposes. This includes aerodromes served only by GPS-based approaches.

Pilots can take credit for a GNSS-based approach at an alternate aerodrome when all of the following conditions are met:

- (a) A usable approach at the planned destination is served by a functioning traditional aid. This is to ensure that an approach is available in the event of a widespread GPS outage. (Good airmanship dictates that the weather forecast at the destination should provide confidence that the approach could be used successfully.) This approach must be completely independent of GNSS. Note that this precludes the GNSS in lieu of ground-based aids credit;
- (b) The published LNAV minima are the lowest landing limits for which credit may be taken when determining alternate weather minima requirements. No credit may be taken for LNAV/VNAV or LPV minima;
- (c) The pilot-in-command verifies that the integrity, provided by RAIM or WASS, and that is required for an LNAV approach, is expected to be available at the planned alternate aerodrome at the ETA, taking into account predicted satellite outages; and
- (d) For GPS TSO C129/C129a avionics, periodically during the flight, and at least once before the mid-point of the flight to the destination, the pilot-in-command verifies that approach-level RAIM is expected to be available at the planned alternate aerodrome at the ETA. This may be accomplished using the RAIM prediction capability of the avionics. If an in-flight prediction indicates that approach-level RAIM will not be available at the alternate, the pilot should plan accordingly. (In-flight predictions are not required for TSO C145a/C146a avionics.)

For the purposes of determining alternate weather minima per TC AIM RAC 3.14.1 or the CAP GEN section, LNAV/VNAV shall be considered to be a non-precision approach.

NOTE: These provisions are applicable to meet the legal flight planning requirements for alternate airports. Once airborne, pilots are free to re-plan as needed to accommodate changing situations while exercising good airmanship.

Taking credit for RNAV (GPS) and RNAV (GNSS) approaches at an alternate aerodrome for IFR flight plan filing purposes is possible because the availability of RAIM or WAAS integrity to support non-precision approaches is normally very high. However, when satellites are out of service, availability could decrease. Consequently, it is necessary to determine satellite status to ensure that the necessary level of integrity will be available at the ETA at the alternate, as indicated by 3.15.12(c), above. The procedures for this are explained in the next two sections.

3.15.12.1 GNSS Approaches at Alternate Aerodromes – GPS (TSO C129/C129a) Avionics

The status of the GPS constellation may be obtained through the FAA by contacting a NAV CANADA flight information centre (FIC) and requesting the international NOTAM file KNMH.

A procedure that meets the requirement to ensure that approach-level RAIM will be available at the alternate for TSO C129/C129a avionics is:

- (a) Determine the ETA at the proposed alternate aerodrome following a missed approach at the destination.
- (b) Check GPS NOTAM (KNMH) file for a period of 60 min before and after the ETA. If not more than one satellite outage is predicted during that period, then 3.15.12(c) is satisfied. If two or more satellites are anticipated to be unserviceable during the ETA \pm 60-min period, then it is necessary to determine if approach-level RAIM will be available, taking into account the reduced availability

resulting from the outages. This may be accomplished by using commercially-available dispatch RAIM prediction software, acquiring a current almanac, and manually deselecting those satellites for the times described in the NOTAM.

The RAIM availability requirement is satisfied if the resulting prediction indicates that RAIM will be unavailable for a total of 15 min or less during the ETA \pm 60-min period.

It may be possible to change the alternate or adjust the departure time (and hence the ETA at the alternate) and re-run the prediction to find a time for which the required RAIM availability is achieved, or simply to find a time when fewer than two satellite outages are predicted.

3.15.12.2 GNSS Approaches at Alternate Aerodromes – WAAS Avionics

Verifying that an LNAV approach is expected to be available is less complicated for operators using WAAS avionics (TSO C145a/C146a). Simply check the national (CYHQ) and FIR NOTAM files to ensure that the WAAS NOTAM system has not failed, and that no widespread WAAS outages have occurred, and then check the aerodrome NOTAM file for the alternate to ensure that LNAV will be available.

The NOTAM system automatically evaluates if sufficient integrity will be available from WAAS GEO satellite messages. In the event of a widespread outage of WAAS messages (as in the rare case of a GEO satellite or total system failure), or at an aerodrome outside the GEO coverage area, it determines if approach-level RAIM, as computed by a WAAS receiver, will be available. For all of these situations, the absence of an aerodrome NOTAM will give the pilot a reasonable assurance that an LNAV approach will be available.

If the WAAS NOTAM system has failed, a national NOTAM will be issued, indicating that WAAS is unmonitored. In this case, the pilot may use the procedure described in the preceding section for TSO C129/C129a avionics. This will provide a safe, although conservative indication of the availability of LNAV.

3.15.13 Next Generation GNSS

The U.S. has started planning for the next-generation GPS satellites, and Europe is proceeding with Galileo, which should be interoperable with GPS. These new systems will have features that improve performance considerably. Both will transmit higher power signals on at least two frequencies in protected navigation bands. Because ionospheric delay is related to frequency, next-generation avionics will be able to calculate the delay directly. This will mean that SBAS should readily support CAT I approaches over wide areas because the greatest challenge for today's SBAS is ensuring the integrity of the ionospheric corrections.

Latest estimates suggest that the Galileo constellation should be commissioned for aviation use by 2010, while the modernized GPS constellation should be fully operational by 2015.

3.15.14 Required Navigation Performance (RNP) and SatNav

In the future, standards for operations in specified airspace or to fly specific procedures will likely follow the RNP concept. In principle, instead of legislating that aircraft be equipped with specific avionics to operate within designated airspace, an RNP level will be specified. The pilot and operator will be responsible for ensuring that the aircraft has the proper equipment.

RNP is based on an RNAV system, but uses a total performance-based approach to ensure a high probability of containment within a defined corridor.

This requires availability of containment integrity and continuity. Since all SatNav systems are designed to these standards, it is expected that SatNav will support these advanced operations.

Potential benefits expected from RNP include tighter lateral and longitudinal separation, more direct routings, and lower approach minima and increased capacity at certain airports. There are, however, other factors to consider when implementing RNP, including the availability of surveillance and communications. Therefore, separation standards will depend on total system performance, not just navigation performance.

3.15.15 GNSS Vulnerability – Interference/Anomaly Reporting

One of the most controversial issues surrounding SatNav is its ability to become a “sole means” system, thus allowing the decommissioning of traditional ground aids.

Recent studies confirmed that interference (unintentional and intentional) is the key concern, because GNSS signals are very weak. In reality, intentional interference is the key threat, because a well-regulated spectrum and the fact that next-generation satellites will broadcast on multiple frequencies make the probability of unintentional interference negligible. The solution will be some combination of ground-based systems, on-board systems (e.g. IRS) and operating procedures. The appropriate mix for a given area will result from careful analysis of threats, area complexity, benefits, costs and risk acceptance.

The primary goal when developing a mitigation strategy is to ensure safety. A secondary but very important goal is to reduce disruption and economic impact to a minimum. If the impact of intentional interference is reduced to the nuisance level, it will not be worth the effort to interfere with the signal.

Decisions on the retention of ground aids will be based on an area-specific analysis. Approach guidance is a critical application, but this does not mean that each approach would require backup guidance. The number of backup approaches in an area would be based on a thorough analysis of the hazard and on ensuring that all aircraft could land safely somewhere.

Vulnerability and backup issues must be coordinated globally to ensure that a uniform and appropriate strategy is applied by all States. Material on the subject was presented at the 11th ICAO Air Navigation Conference, held in September 2003, and should help countries make planning decisions.

Canada must find a solution that is matched to the traffic density and potential for interference in Canada. NAV CANADA is actively researching this issue, and will make decisions in consultation with its customers and Transport Canada. Regardless, even if SatNav never attains “sole means” status for all phases of flight, it will deliver significant safety and efficiency benefits to aircraft operators.

In the near term, pilots using IFR-certified GNSS avionics are protected against interference-induced navigation errors by integrity monitoring provided by RAIM or WAAS. A degraded SNR can also hinder navigation. In the event of suspected GPS interference or other problems with GPS, pilots should advise ATS, and, if necessary, revert to using traditional aids for navigation. Pilots are also requested to complete a “GPS Anomaly Report Form” (Figure 3.4), or equivalent, in order to assist in the identification and elimination of sources of interference or degradation of the GPS signal.

3.15.16 Proper Use of GNSS

SatNav offers a great opportunity to improve aviation safety and efficiency. Many pilots are already benefiting from the advantages of GPS as a principal navigation tool for IFR flight or for VFR operations. To ensure safety, pilots must use GNSS properly. Here are some safety tips:

- Use only IFR-certified avionics for IFR flights because hand-held and panel-mount VFR do not provide the integrity needed for IFR operations;
- For IFR flight, a valid database shall be used for approach—a new one is required every 28 or 56 days;
- Data storage limitations have resulted in some manufacturers omitting certain data from the avionics database. Prior to flight to remote or small aerodromes, pilots should verify that all procedures that could be required are present in the database;

- Do not become approach designers—approach designers require special training and specific tools, and there are many levels of validation before an approach is commissioned. Furthermore, the receiver RAIM level and course deviation indicator (CDI) sensitivity will not be appropriate if an approach is not retrieved from the avionics database;
- Never fly below published minimum altitudes while in instrument conditions. Accidents have resulted from pilots relying too much on the accuracy of GNSS;
- VFR receivers may be used to supplement map reading in visual conditions, but are not to be used as a replacement for current charts;
- Hand-held receivers and related cables should be positioned carefully in the cockpit to avoid the potential for electromagnetic interference (EMI), and to avoid interfering with aircraft controls; hand-held units with valid databases can also be useful in emergencies when IFR units fail; and
- When navigating VFR, resist the urge to fly into marginal weather. The risk of becoming lost is small when using GNSS, but the risk of controlled flight into terrain or obstacles increases in low visibility. VFR charts must also be current and updated from applicable NOTAM, and should be the primary reference for avoiding alert areas, etc. Some VFR receivers display these areas, but there is no guarantee that the presentation is correct, because there is no standard for such depictions.

3.15.17 Communication, Navigation, Surveillance Implementation Team (CNS IT)

NAV CANADA and Transport Canada work together on GNSS implementation and transition issues through the joint CNS IT. The CNS IT has taken over the functions of the GNSS Implementation Team (GIT). One of the concerns of the CNS IT is ensuring that new GNSS services meet aviation’s stringent safety standards while serving the needs of the Canadian aviation community.

The CNS IT often forms working groups to address specific issues. These groups discuss the expansion of approvals to use SatNav or the resolution of an operational or technical problem. The working groups present the results of their work to the CNS IT for discussion, endorsement and forwarding to Transport Canada and NAV CANADA management for final approval.

The CNS IT follows a safety management methodology that dictates that a risk assessment be completed before implementing new services.

3.15.18 GNSS User Comments

NAV CANADA's CNS Service Design (CNS SD) Branch is constantly assessing the capabilities and limitations of SatNav in order to bring maximum benefits to users as soon as possible. CNS SD staff participate in the development of international standards, keep abreast of technology developments and assess the operational application of GNSS.

Through the CNS IT, NAV CANADA and Transport Canada are working with national user organizations on GPS and other initiatives to make aircraft operations more efficient. As a pilot or operator, you can relay your comments on GNSS and related issues via one of these organizations, or you can contact the CNS SD directly:

NAV CANADA
CNS Service Design
77 Metcalfe Street
Ottawa ON K1P 5L6

Fax: 613-563-7995
E-mail: satnav@navcanada.ca
Web site: [<www.navcanada.ca>](http://www.navcanada.ca)



Figure 3.4—GPS Anomaly Report Form

ORIGINATOR INFORMATION	
<u>Prepared by:</u>	<u>Date:</u>
<u>Address:</u>	<u>Telephone:</u>
	<u>Fax:</u>
	<u>E-mail:</u>
GPS EQUIPMENT INFORMATION	
<u>Aircraft Registration:</u>	<u>Aircraft Type:</u>
<u>GPS Receiver Type:</u> <input type="checkbox"/> Hand-held <input type="checkbox"/> Panel Mount <input type="checkbox"/> FMS Sensor	
<u>TSO C129 Approved?</u> Yes / No	<u>Installation Approved for:</u> <input type="checkbox"/> IFR <input type="checkbox"/> VFR
<u>GPS Make/Model:</u>	
<u>GPS Antenna Location:</u> <input type="checkbox"/> on aircraft <input type="checkbox"/> suction cup <input type="checkbox"/> on unit	
<u>Remarks:</u>	
OCCURRENCE INFORMATION	
<u>Date of Occurrence:</u>	<u>Approx. Altitude:</u>
<u>Approx. Time of Occurrence:</u>	
<u>Approx. Location of Occurrence (Lat./Long. or nearest city or landmark):</u>	
<u>What did the receiver indicate during the problem:</u>	
<input type="checkbox"/> Large position errors (details):	<input type="checkbox"/> Degraded signal to noise (details):
<input type="checkbox"/> Loss of integrity (RAIM warning/alert):	<input type="checkbox"/> Other:
<input type="checkbox"/> Loss of coverage (details):	
<input type="checkbox"/> Loss of satellites in view (details):	
<u>Problem duration:</u> <input type="checkbox"/> Seconds <input type="checkbox"/> Minutes <input type="checkbox"/> Hours <input type="checkbox"/> Days	
<u>What did the receiver indicate prior to the problem:</u>	
<u>Action taken by operator to correct problem, or did the anomaly resolve itself:</u>	
<u>Possible causes (e.g. on-board VHF radio transmission, TV Radio transmitter antennas, buildings, suspicious activity)</u>	
<u>Comments or details:</u>	
<u>Return form to:</u>	SatNav Program Office NAV CANADA 77 Metcalfe Street Ottawa ON K1P 5L6 Fax: 613 563-7995

COM

4.0 TIME SIGNALS

4.1 GENERAL

The National Research Council time signals emanate from Ottawa station CHU on the frequencies 3330, 7335 and 14670 kHz. Transmissions are AM, continuous and simultaneous on all frequencies and the area of coverage includes most of North America and many other parts of the world.

The listener hears a beat for each mean second which is a pulse 1/5 of a second long except that the zero pulse of each minute is increased to 1/2 second long and the zero pulse for each hour is a full second long followed by 40 seconds of silence. In order to permit the listener to detect half-minutes, the 29th pulse of each minute is omitted.

A voice announcement of the time is made each minute in the ten-second gap between the 50th and 60th seconds. The announced time refers to the beginning of the minute pulse which follows the announcement. The voice announcements are made in English and French using the 24-hour system.

5.0 RADIO COMMUNICATIONS

5.1 GENERAL

This part deals with radio communications between aircraft and ground stations. Particular emphasis is placed on radiotelephony procedures that are intended to promote understanding of messages and reduce communications time.

The primary medium for aeronautical communications in Canada is VHF-AM in the frequency range of 118 to 137 MHz. For increased range in the northern areas and the North Atlantic, HF-SSB is available in the frequency range of 2.8 to 22 MHz.

Regulations

Operator's Certificates: In accordance with the

Radiocommunication Regulations, a person may operate radio apparatus in the aeronautical service only where the person holds a Restricted Operator Certificate with Aeronautical Qualification, issued by Industry Canada.

Station Licences: All radio equipment used in aeronautical services required to be licensed by Industry Canada.

For complete information on the requirements for communication in Canada, please consult the *Study Guide for the Radiotelephone Operator's Restricted Certificate Aeronautical*, (RIC21). This study guide is available from the nearest Industry Canada district office or by calling (613) 998-4149.

5.2 LANGUAGE

The use of English and French for aeronautical radio communications in Canada is detailed in sections 602.133, 602.134, and 602.135 of the CARs. The regulations specify that air traffic services shall be provided in English and sets out the locations where services shall be provided in French as well. The tables containing the names of those locations, as well as the pertinent section of the CARs are contained in COM Annex A.

For safety and operational efficiency, once the language to be used has been determined, the pilot should refrain from changing language in the course of communications without formal notification to that effect. In addition, pilots should endeavour to become thoroughly familiar with the aeronautical phraseology and terminology applicable to the type of service being provided in the official language of their choice.

5.3 VHF COMMUNICATION FREQUENCIES—CHANNEL SPACING

The standard VHF A/G channel spacing in Canada is 25 kHz. A 760 channel transceiver is necessary for operation of 25 kHz channels. In some areas of Europe, channel spacing has been reduced to 8.33 kHz.

This channel spacing means that some operators with 50 kHz capability will have their access to certain Canadian airspace and airports restricted as 25 kHz channels are implemented for ATC purposes. Similarly, where ATC makes use of 8.33 kHz channels in Europe, restrictions may also apply.

Because the frequency selectors on some 25 kHz transceivers do not display the third decimal place, misunderstanding may exist in the selection of frequencies. With such transceivers, if the last digit displayed includes 2 and 7, then the equipment is capable of 25 kHz operations.

Example:

Toronto Centre: 132.475 (actual frequency)
 ATC Assigned Frequency: 132.47 (digit 5 omitted)
 Aircraft Radio Display: 132.475 or 132.47

In either case, the aircraft radio is actually tuned to the proper frequency.

5.4 USE OF PHONETICS

Phonetic letter equivalents shall be used for single letters or to spell out groups of letters or words as much as practicable. The ICAO phonetic alphabet should be used.

THE PHONETIC ALPHABET AND MORSE CODE

LETTER	CODE	WORD	PRONUNCIATION	LETTER	CODE	WORD	PRONUNCIATION
A	·-·-	Alfa	AL fah	N	-·-	November	no VEM ber
B	··-·-	Bravo	BRAH VOH	O	---·-	Oscar	OSS cah
C	·-·-·	Charlie	CHAR lee or SHAR lee	P	·-·-·	Papa	pah PAH
D	··-·-	Delta	DELL tah	Q	---·-	Quebec	keh BECK
E	··-·-	Echo	ECK oh	R	·-·-·	Romeo	ROW me oh
F	··-·-	Foxtrot	FOKS trot	S	··-·-	Sierra	see AIR rah
G	··-·-	Golf	GOLF	T	··-·-	Tango	TANG go
H	··-·-	Hotel	hoh TELL	U	··-·-	Uniform	YOU nee form or OO nee form
I	··-·-	India	IN dee ah	V	··-·-	Victor	VIK tah
J	··-·-	Juliett	JEW lee ETT	W	··-·-	Whiskey	WISS key
K	··-·-	Kilo	KEY loh	X	··-·-	X-ray	ECKS RAY
L	··-·-	Lima	LEE mah	Y	··-·-	Yankee	YANG key
M	··-·-	Mike	MIKE	Z	··-·-	Zulu	ZOO loo

NUMBER	CODE	WORD	PRONUNCIATION	NUMBER	CODE	WORD	PRONUNCIATION
0	-----	Zero	ZE RO	5	·····	Five	FIFE
1	·-----	One	WUN	6	·-----	Six	SIX
2	··-----	Two	TOO	7	··-----	Seven	SEV en
3	···-----	Three	TREE	8	···-----	Eight	AIT
4	····-----	Four	FOW er	9	····-----	Nine	NIN er

When spoken, capitalized syllables are given equal stress, e.g., ECKS-RAY. When only one syllable is capitalized, that syllable is given primary stress, e.g., NINE-er.

5.5 AIRWAYS AND AIR ROUTES DESIGNATION

Phonetics are used with the designation of Canadian airways and air routes.

Examples:

AIRWAYS	<i>WRITTEN</i>	<i>SPOKEN</i>
	G1	GOLF1
	A2	ALFA 2
	J500	JET 500
AIR ROUTES	RR3	ROMEO
		ROMEO 3
	BR4	BRAVO
		ROMEO 4

5.6 DISTANCE REPORTING

Distance reporting based on RNAV and GPS will be provided in miles, e.g. 30 mi. from Someplace. When distance reports are based on DME, pilots will state DME, e.g. 30 DME from Someplace.

5.7 USE OF NUMBERS

All numbers except whole thousands should be transmitted by pronouncing each digit separately:

Examples:

572 FIVE SEVEN TWO
11000 ONE ONE THOUSAND

Altitude above sea level is expressed in thousands and hundreds of feet. Separate digits must be used to express flight levels.

Examples:

2700 TWO THOUSAND SEVEN HUNDRED
FL260 Flight Level TWO SIX ZERO

Aircraft type numbers, wind speed and cloud base may be expressed in group form:

Examples:

DC10 DC TEN
Wind 270/10 WIND TWO SEVEN ZERO AT TEN
3400 broken THREE THOUSAND FOUR HUNDRED BROKEN

Time – Co-ordinated Universal Time (UTC)

Examples:

0920Z ZERO NINE TWO ZERO ZULU
09 minutes ZERO NINE (past the next hour)

Aircraft headings are given in groups of three digits prefixed by the word “Heading”. If operating within the Southern Domestic Airspace, degrees are expressed in “magnetic”. If operating within the Northern Domestic Airspace, degrees are expressed in “True”.

Example:

005 degrees HEADING ZERO ZERO FIVE

Aerodrome elevations are expressed in feet, prefixed by the words “Field Elevation”.

Example:

150 FIELD ELEVATION ONE FIVE ZERO

Transponder codes are preceded by the word SQUAWK.

Example:

code 1200 SQUAWK ONE TWO ZERO ZERO

Numbers containing a decimal point are expressed with the decimal point in the appropriate sequence by the word DECIMAL except that for VHF or UHF frequencies, the decimal point may be omitted if the omission is not likely to cause any misunderstanding.

5.8 CALL SIGNS

5.8.1 Civil Aircraft

In radio communications, use phonetics at all times if the call sign consists of the aircraft’s registration.

The word “heavy” is used to indicate an aircraft is certified for a maximum take-off weight of 300 000 lbs or more.

After communication has been established, and when no likelihood of confusion exists, the word “heavy” may be omitted, and call signs may be abbreviated.

COM

A MEDEVAC is a flight responding to a medical emergency for the transport of patients, organ donors, organs or other urgently needed life-saving medical material. This can also apply to certain medical flights, including helicopters, which may be designated as Air Ambulance Flights.

Canadian and Foreign Air Carriers:

- (a) *Initial contact:* The operator's radiotelephony designator followed by: the flight number, or the last four characters of the aircraft registration, and the word "heavy" if applicable.

Examples:

Air Canada 149 Heavy (AIR CANADA ONE FOUR NINE HEAVY)
Air Canada FTTHA Heavy (AIR CANADA FOXTROT TANGO HOTEL ALFA HEAVY)
Speedbird GABCD Heavy (SPEEDBIRD GOLF ALFA BRAVO CHARLIE DELTA HEAVY)

- (b) *Subsequent communications:* The word "heavy" may be omitted, and where the aircraft registration is used, it may be abbreviated to the operator's radiotelephony designator and at least the last two characters of the aircraft registration.

Examples:

Air Canada HA (AIR CANADA HOTEL ALFA)
Speedbird CD (SPEEDBIRD CHARLIE DELTA)

Canadian Private Civil Aircraft and Canadian or Foreign Carriers Without an Assigned Radiotelephony Designator:

- (a) *Initial contact:* The manufacturer's name or the type of aircraft, followed by the last four characters of the registration.

Examples:

Cessna GADT (CESSNA GOLF ALFA DELTA TANGO)
Aztec FADT (AZTEC FOXTROT ALFA DELTA TANGO)

NOTE: The words "helicopter," "glider" or "ultralight" are an acceptable substitute for the type of aircraft when these types of aircraft are used.

- (b) *Subsequent communications:* May be abbreviated to the last three characters of the registration, if this abbreviation is initiated by ATS.

Examples:

Cessna GADT becomes "ADT" (ALFA DELTA TANGO)
Aztec FADT becomes "ADT" (ALFA DELTA TANGO)

Foreign Private Civil Aircraft:

- (a) *Initial contact:* The manufacturer's name or the type of aircraft, followed by the full aircraft registration.

Example:

Mooney-N6920K (MOONEY NOVEMBER SIX NINE TWO ZERO KILO).

- (b) *Subsequent communications:* May be abbreviated to the last three characters of the registration, if this abbreviation is initiated by ATS.

Example:

Mooney-N6920K becomes 20K (TWO ZERO KILO).

Medical Evacuation Flights (MEDEVAC):

- (a) *Initial contact:* The manufacturer's name or type of aircraft or operator's radiotelephony designator, followed by:
- the flight number and the word MEDEVAC, or
 - the last four characters of the aircraft registration and the word MEDEVAC.

Examples:

Austin 101 MEDEVAC (AUSTIN ONE ZERO ONE MEDEVAC)
Cessna FABC MEDEVAC (CESSNA FOXTROT ALFA BRAVO CHARLIE MEDEVAC).

- (b) *Subsequent communications:* May be abbreviated as per normal procedures, retaining the word MEDEVAC.

Formation Flights:

- (a) *Initial contact:* The aircraft call sign or the last four characters of the aircraft's registration followed by "Flight, Formation of (number of aircraft)".

Examples:

Griffin 11, Flight, Formation of 4 (GRIFFIN ONE ONE, FLIGHT, FORMATION OF FOUR)
FLVM, Flight, Formation of 2 (FOXTROT LIMA VICTOR MIKE, FLIGHT, FORMATION OF TWO)

- (b) *Subsequent communications:* The number of aircraft may be eliminated. All subsequent communications to and from the formation should include the word "Flight".

Examples:

Griffin 11, Flight (GRIFFIN ONE ONE, FLIGHT)
FLVM, Flight (FOXTROT LIMA VICTOR MIKE, FLIGHT)

Similar Sounding Call Signs:

If communicating with two or more aircraft that are using the same flight number or similar sounding identifications, ATS will advise each of the aircraft concerned of the other's presence.

In order to further minimize the chance for call sign confusion, ATS may:

- (a) restate the operator's radiotelephony designator of the aircraft involved after the flight number, for emphasis.

Examples:

JAZZ EIGHT EIGHT ONE THREE JAZZ
TRANSPORT EIGHT ONE THREE TRANSPORT

(b) add the type of aircraft to the identification:

Examples:

CHEROKEE ALFA BRAVO CHARLIE

or

(c) instruct aircraft using the same flight number or similar sounding identification to use:

- (i) the aircraft registration; or
- (ii) the operator's radiotelephony designator, followed by at least the last two characters of the aircraft registration.

Example:

JAZZ NOVEMBER DELTA
CANJET ECHO PAPA ALFA

5.8.2 Ground Stations

General

The aerodrome name as published in the CFS is used to form the call sign to the associated ground stations. When the aerodrome name is different from the community (location) name, it will be published following the community (location) name and will be separated by a diagonal (/). Exceptions should be listed in the COMM Section of the CFS.

Example:

TORONTO/LESTER	B.	PEARSON	INTL	ONT
COMM	TWR	Toronto	TORONTO TOWER	

Other Examples of Call Signs:

	CFS		Call Sign
	COMM		
Area Control Centre	CENTRE		MONTRÉAL CENTRE
Flight Service Station	RADIO		MONCTON RADIO
Terminal Control	TML		QUÉBEC TERMINAL
Arrival Control	ARR		VANCOUVER ARRIVAL
Departure Control	DEP		EDMONTON DEPARTURE
Clearance Delivery	CLNC DEL		OTTAWA CLEARANCE DELIVERY
Community Aerodrome Radio Station	APRT RDO		REPULSE BAY AIRPORT RADIO
Pilot to Forecaster	PMSV		COMOX METRO
Apron Advisory Service	APRON		MIRABEL APRON
Remote Communication Outlet	RCO	Rouyn rdo	ROUYN RADIO
Mandatory Frequency	MF	rdo	FREDERICTON RADIO
Aerodrome Traffic Frequency	ATF		MANIWAKI UNICOM
Peripheral Station	PAL	Winnipeg Ctr	WINNIPEG CENTRE
VFR Advisory	VFR ADV		TORONTO TERMINAL

5.8.3 RCO

An RCO is a facility remotely established from an FSS or flight information centre (FIC) to provide communications between aircraft and this FSS or FIC. They are intended only for FISE and RAAS communications. There is only one procedure to be used to establish communications on any RCO.

On initial contact, the pilot should state the identification of the ATS unit (FSS or FIC) controlling the RCO, the aircraft identification, and the name of the location of the RCO followed by the individual letters R-C-O in a non-phonetic form.

Example:

HALIFAX RADIO, CHEROKEE GOLF ALFA BRAVO
CHARLIE ON THE FREDERICTON R-C-O

The name of the RCO assists the flight service specialist in identifying the RCO on which the call is made, as the same person can monitor many frequencies. The specialist will respond with the aircraft identification followed by the identification of the unit controlling the RCO.

Example:

GOLF ALFA BRAVO CHARLIE, HALIFAX RADIO

5.9 STANDARD RADIO TELEPHONY

General

The *Radio communication Regulations* specify that aeronautical radio communications are restricted to communications relating to

- the safety and navigation of an aircraft;
- the general operation of the aircraft; and
- the exchange of messages on behalf of the public.

In addition, a person may operate radio apparatus only to transmit a non-superfluous signal or a signal containing non-profane or non-obscene radiocommunications.

Pilots should

- (a) send radio messages clearly and concisely using standard phraseology whenever practical;
- (b) plan the content of the message before transmitting; and
- (c) listen out before transmitting to avoid interference with other transmissions.

Message: Radiotelephony traffic generally consists of four parts: the call-up, the reply, the message and the acknowledgement.

Pilot: REGINA TOWER, (THIS IS) CESSNA FOXTROT BRAVO CHARLIE DELTA (OVER).

Tower: CESSNA FOXTROT BRAVO CHARLIE DELTA, REGINA TOWER.

Pilot: *REGINA TOWER, FOXTROT BRAVO CHARLIE DELTA, TEN SOUTH THREE THOUSAND FIVE HUNDRED FEET VFR LANDING INSTRUCTIONS*

Tower: *BRAVO CHARLIE DELTA, REGINA TOWER, RUNWAY TWO SIX, WIND TWO THREE ZERO AT TEN, ALTIMETER TWO NINE NINE TWO, CLEARED TO THE CIRCUIT.*

Pilot: *BRAVO CHARLIE DELTA.*

The terms “this is” and “over” may be omitted, and if no likelihood of confusion exists, the call sign for the agency being called maybe abbreviated as follows:

Pilot: *TOWER, BRAVO CHARLIE DELTA, CONFIRM RIGHT TURN.*

Message Acknowledgement: Pilots should acknowledge the receipt of all messages directed to them, including frequency changes. Such acknowledgement may take the form of a transmission of the aircraft call sign, a repeat of the clearance with the aircraft call sign or the call sign with an appropriate word(s).

Tower: *VICTOR LIMA CHARLIE, CLEARED TO LAND.*

Pilot: *VICTOR LIMA CHARLIE.*

Tower: *FOXTROT VICTOR LIMA CHARLIE, CONFIRM YOU ARE AT FIVE THOUSAND.*

Pilot: *FOXTROT VICTOR LIMA CHARLIE, AFFIRMATIVE.*

NOTE: The clicking of the microphone button as a form of acknowledgement is not an acceptable radio procedure.

5.10 COMMUNICATIONS CHECKS

The readability scale from one to five has the following meaning:

1. unreadable;
2. readable now and then;
3. readable with difficulty;
4. readable; and
5. perfectly readable.

The strength scale from one to five used in HF communications has the following meaning:

- | | |
|----------|---------------|
| 1. bad; | 4. good; and |
| 2. poor; | 5. excellent. |
| 3. fair; | |

Communications checks are categorized as follows:

Signal Check — if the test is made while the aircraft is airborne.

Pre-flight Check — if the test is made prior to departure.

Maintenance Check — if the test is made by ground maintenance.

Pilot: *THOMPSON RADIO, CESSNA FOXTROT ALFA BRAVO CHARLIE, RADIO CHECK ON FIVE SIX EIGHT ZERO.*

Radio: *FOXTROT ALFA BRAVO CHARLIE, THOMPSON RADIO, READING YOU STRENGTH FIVE, OVER.*

5.11 EMERGENCY COMMUNICATIONS

General

An emergency situation is classified in one of the two following categories, in accordance with the degree of danger or hazard present:

- (a) distress is a condition of being threatened by serious and/or imminent danger and of requiring immediate assistance. The spoken word for distress is MAYDAY, and it is pronounced three times.
- (b) urgency is a condition concerning the safety of an aircraft or other vehicle, or of some person on board or within sight, but which does not require immediate assistance. The spoken word for urgency is PAN PAN, and it is pronounced three times.

The first transmission of the distress call and message by an aircraft should be on the air-to-ground frequency in use at the time. If the aircraft is unable to establish communication on the frequency in use, the distress call and message should be repeated on the HF general calling or distress frequency 3 023.5 kHz, 5 680 kHz, 121.5 MHz, 406.1 MHz, or other distress frequency available, such as 2 182 kHz, in an effort to establish communications with any ground station or the maritime service.

The distress call shall have absolute priority over all other transmissions. All stations hearing it shall immediately cease any transmission that may interfere with it and shall listen on the frequency used for the distress call.

Example of a distress message from an aircraft:

MAYDAY, MAYDAY, MAYDAY, THIS IS FOXTROT ZULU X-RAY YANKEE, FOXTROT ZULU X-RAY YANKEE, FOXTROT ZULU X-RAY YANKEE, FIVE ZERO MILES SOUTH OF YELLOWKNIFE AT ONE SEVEN TWO FIVE ZULU, FOUR THOUSAND, NORSEMAN, ICING, WILL ATTEMPT CRASH LANDING ON ICE, FOXTROT ZULU X-RAY YANKEE, OVER.

Example of an urgency message addressed to all stations:

PAN PAN, PAN PAN, PAN PAN, ALL STATIONS, ALL STATIONS, ALL STATIONS, THIS IS TIMMINS RADIO, TIMMINS RADIO, TIMMINS RADIO, EMERGENCY DESCENT AT TIMMINS AIRPORT, ATC INSTRUCTS ALL AIRCRAFT BELOW SIX THOUSAND FEET WITHIN RADIUS OF ONE ZERO MILES OF TIMMINS NDB LEAVE EAST AND NORTH COURSES IMMEDIATELY, THIS IS TIMMINS RADIO OUT.

Emergency procedures are contained in RAC and SAR.

121.5 MHz in the Air Navigation System (ANS)

Only control towers and FSSs have 121.5 MHz capability, and this emergency frequency is only monitored during these facilities’ hours of operation. Remote communication facilities (PAL, RAAS RCO and FISE RCO) do not have 121.5 MHz capability.

During an emergency, a pilot has the following options for communicating with ATS:

- When within radio reception of a control tower or FSS during the facility’s hours of operation, call ATS on the tower frequency/FSS mandatory frequency (MF) or 121.5 MHz. It is recommended that pilots use the normal or frequency in use at the time.
- When within radio reception of a remote communications facility (FISE RCO, RAAS RCO or PAL), call ATS on the published frequency (Note: FISE RCOs and PALs operate 24 hr, while most RAAS RCOs operate part time).
- When out of range for VHF communications (for example at low altitude, along a highway corridor), pilots may use a cell phone if they have cell phone coverage (see COM 5.15).
- If beyond the radio reception of an ATS facility, or when outside the facility’s hours of operation, broadcast on 121.5 MHz or 126.7 MHz, or both, for assistance from other pilots who may be monitoring the frequency.

Satellite Voice

Inmarsat, in conjunction with ICAO, has developed a telephone numbering plan to facilitate the use of satellite voice by suitably equipped aircraft as a backup to the existing primary A/G facilities. The use of SATCOM voice for this purpose requires on board embedded equipment. Permanent satellite voice equipment is installed and tested in accordance with appropriate certification and airworthiness standards.

The telephone numbering plan assigns a code specific to each FIR. When a ground earth station receives the unique code from the aircraft via satellite, it is converted and the call is routed to the appropriate ATS unit.

For emergency communications, the Inmarsat short codes and public switched telephone network (PSTN) numbers are as follows:

Location	Short Code/ Inmarsat	PSTN Number
Gander Oceanic FIR	431603	1-709-651-5324
Gander Domestic FIR	431602	1-709-651-5315
Gander Radio	431613	1-709-651-5328
Moncton FIR	431604	1-506-867-7173
Montréal FIR	431605	1-514-633-3211
Toronto FIR	431606	1-905-676-4509
Winnipeg FIR	431608	1-204-983-8338
Edmonton FIR	431601	1-780-890-8397
Vancouver FIR	431607	1-604-586-4500

5.12 MONITORING OF EMERGENCY FREQUENCY 121.5 MHz

A pilot should continuously monitor 121.5 MHz when operating within sparsely settled areas or when operating a Canadian aircraft over water more than 50 NM from shore unless:

- (a) essential cockpit duties or aircraft electronic equipment limitations do not permit simultaneous monitoring of two VHF frequencies; or
- (b) the pilot is using other VHF frequencies.

5.13 VHF FREQUENCY ALLOCATIONS

5.13.1 Air Traffic Services

ATS frequencies are published in the *Canada Flight Supplements*(CFS), aeronautical charts and the *Canada Air Pilot* (CAP).

5.13.2 Soaring

Frequency 123.4 MHz is allocated for the use of soaring activities, which include balloons, gliders, sailplanes, ultralights and hang gliders. The use of this frequency for these activities includes air-to-air, air-to-ground instructional and air-to-ground aerodrome traffic communications; the use of this frequency as an *aerodrome traffic frequency* (ATF) is normally restricted to privately operated aerodromes used primarily for these activities.

5.13.3 Air-to-Air

For air-to-air communications between pilots within the Canadian Southern Domestic Airspace, the correct frequency to use is 122.75 MHz; in the Northern Domestic Airspace and the North Atlantic, the frequency allocated by ICAO is 123.45 MHz.



5.14 USE OF FREQUENCY 5680 kHz

This frequency provides long-range A/G communications coverage in the remote areas of Canada for the provision of FISE beyond the range of VHF communications. Aircraft must use SSBs when communicating on 5680 kHz.

HF 5680 kHz RCOs

Location	Controlling ATS Unit
Baker Lake, Nunavut.....	North Bay FIC
Inuvik, Northwest Territories.....	North Bay FIC
Iqaluit, Nunavut.....	North Bay FIC
Kuujuuaq, Quebec.....	Quebec FIC
Kuujuarapik, Quebec.....	Quebec FIC
Resolute Bay, Nunavut.....	North Bay FIC
Roberval, Quebec.....	Quebec FIC
St. Anthony, Newfoundland & Labrador.....	Halifax FIC
Thompson, Manitoba.....	Winnipeg FIC
Whitehorse, Yukon.....	Whitehorse FIC
Yellowknife, Northwest Territories.....	North Bay FIC

5.15 PHONE USE DURING A RADIO COMMUNICATIONS FAILURE

COM 5.11 outlines the procedures for emergency communications using existing A/G facilities as the primary source of communications, and satellite voice as a backup.

In the event of an in-flight radio communications failure, and only after normal communications failure procedures have been followed (see RAC 6.3.2.1), the pilot-in-command may attempt to contact the appropriate NAV CANADA ATS unit by means of a conventional cell or satellite phone. Before placing the call, transponder-equipped aircraft should squawk Code 7600 (see RAC 1.9.7).

Public switched telephone network (PSTN) numbers to be used in the event of a communication failure are included in COM 5.11 and published in the CFS.

6.0 AERONAUTICAL FIXED SERVICES – INTERNATIONAL FLIGHTS

6.1 AFS

6.1.1 Voice Systems

Voice systems consist of the ATC Interphone system and AMIS.

6.1.2 AFTN

The AFTN is an integral part of a worldwide system of message switching centres and fixed circuits that allows for aeronautical data exchange between ICAO Member States. Canadian ACCs, FICs, FSSs and other aeronautical facilities are interconnected by the AFTN.

Canada's contribution to the AFTN is provided by the AFTN Message Handling System, owned and operated by NAV CANADA, in Ottawa. This centralized store-and-forward message handling system provides for the real-time reception, storage and delivery of aeronautical data nationally, via AFTN stations within Canada, and internationally via the USA, UK, Iceland and Greenland. Command and control of the AFTN Message Handling System is provided by NAV CANADA's National Systems Control Centre (NSCC). Queries on AFTN service can be directed to the NSCC at:

NAV CANADA
 National Systems Control Centre
 1601 Tom Roberts Avenue
 P.O. Box 9824 Station T
 Ottawa ON K1G 6R2
 AFTN Message Address: ... CYAAMCFA or CYAAYFAX
 Tel.: 613-248-3993
 Fax: 613-248-4001
 E-mail: nscc@navcanada.ca

The standards, recommended practices and procedures for the acceptance, transmission and delivery of messages within the AFTN are in accordance with the provisions of ICAO Annex 10, Volume II and allow for the exchange of the following categories of aeronautical messages:

- (a) distress messages;
- (b) urgency messages;
- (c) flight safety messages;
- (d) meteorological messages;
- (e) flight regularity messages;
- (f) aeronautical information services (AIS) messages;
- (g) aeronautical administrative messages; and
- (h) service messages.

Canadian locations and location indicators are listed in ICAO DOC 7910. Messages addressed to aeronautical stations not directly connected to the AFTN Message Handling System are automatically routed to the nearest aeronautical facility for delivery.

ICAO standards, recommended practices and procedures contained in the following documents apply:

Annex 10—*Aeronautical Telecommunications*;
 DOC 7910—*Location Indicators*;
 DOC 8400—*ICAO Abbreviations and Codes*; and
 DOC 8585—*Designators for Aircraft Operating Agencies, Aeronautical Authorities and Services*.

COM

6.2 INTERNATIONAL A/G SERVICE

Gander international flight service station (IFSS) is the only Canadian aeronautical station providing international aeronautical telecommunication services.

6.2.1 HFAeromobile Operations in the NAT

All NAT HF frequencies are organized into six groups, known as families. The families are identified as NAT Family A, B, C, D, E and F. Initial contact with Gander IFSS on HF radio should be made on families B, C, D or F.

The specific frequencies belonging to each family and their corresponding hours of operation are listed in the table below:

HF Frequencies		
Family A	3 016 kHz	2030Z-0830Z
	5 598 kHz	2030Z-0830Z
	8 906 kHz	0830Z-2230Z
	13 306 kHz	1230Z-1830Z
Family B	2 899 kHz	2030Z-0830Z
	5 616 kHz	24-hr service
	8 864 kHz	0830Z-2230Z
	13 291 kHz	1000Z-2000Z
Family C	2 872 kHz	2030Z-0830Z
	5 649 kHz	24-hr service
	8 879 kHz	0830Z-2230Z
	11 336 kHz	1030Z-1830Z
Family D	2 971 kHz	2030Z-0830Z
	4 675 kHz	2030Z-0830Z
	8 891 kHz	24-hr service
	11 279 kHz	1030Z-1830Z
Family E	2 962 kHz	unavailable
	6 628 kHz	unavailable
	8 825 kHz	unavailable
	11 309 kHz	unavailable
	13 354 kHz	unavailable
	17 946 kHz	unavailable
Family F	3 476 kHz	2030Z-0830Z
	6 622 kHz	1130Z-0730Z
	8 831 kHz	0830Z-2230Z

The allocation of families is generally based on the route of flight of the aircraft. Aircraft whose route, or portion of route, transits oceanic airspace between 43°N and 47°N will generally be assigned Family A; aircraft operating on routes between 47°N and 64°N will generally be assigned Family B or C; aircraft operating on routes north of 62°N will generally be assigned Family D; aircraft operating on routes south of 43°N will generally be assigned Family E; and finally, aircraft operating on routes entirely within the Gander Oceanic and Shanwick Oceanic control areas will generally be assigned Family F.

When an aircraft fails to establish contact with Gander IFSS on the designated frequency, it shall attempt to establish contact on another frequency appropriate to the route. See chart below:

Family	Route Co-ordinates	Description of Route
Family A	Routes between 43°N and 47°N	Central routes
Family B and C	Routes between 47°N and 64°N	Central routes
Family D	Routes north of 62°N	Central routes
Family E	Routes south of 43°N	Central routes
Family F	Routes operating entirely within Gander Oceanic and Shanwick Oceanic control areas.	Gander/Shanwick route

In the event of the overloading of a family actually occurring or being anticipated, aircraft of one or more operators may be offloaded from that family to another appropriate family for the expected duration of the condition. The offloading may be requested by any station, but Shannon and Gander will be responsible for making a decision after co-ordination with all NAT stations concerned.

6.2.2 HF Operations—Anchorage Arctic

Aircraft operating in the Anchorage Arctic CTA/FIR beyond the line-of-sight range of remote control VHF A/G facilities operated from the Anchorage ACC shall maintain communications with Gander Radio and a listening or SELCAL watch on HF frequencies of NAT Delta (NATD) network 2 971 kHz, 4 675 kHz, 8 891 kHz and 11 279 kHz. Additionally, and in view of reported marginal reception of Honolulu Pacific VOLMET broadcast in and adjacent to Canadian airspace, Gander Radio can provide, on request, Anchorage and Fairbanks surface observations and aerodrome forecasts to flight crews.

6.2.3 VOLMET

The VOLMET is meteorological information for aircraft in flight, particularly those over the high seas. The VOLMET contains METARs and aerodrome forecasts (TAF) for selected aerodromes and may be provided either by data link (D-VOLMET) or by voice broadcasts on designated frequencies, normally high frequency (HF).

Information on the content, issue times and transmitter frequencies for North Atlantic VOLMET broadcasts is given in the CFS, Section “D”, Radio Navigation and Communications.

6.3 AVAILABILITY OF SSB

All international HF equipment is operated on SSB J3E emission. In all cases, the USB is employed.

6.4 SELCAL

SELCAL is installed on all international frequencies at Gander Radio. SELCAL provides an automatic and selective method of calling any aircraft. Voice calling is replaced by the transmission of code tones to the aircraft over the international radiotelephony channels. A single selective call consists of a combination of four pre-selected audio tones requiring approximately two seconds of transmission time. The tones are generated in the ground station coder and are received by a decoder connected to the audio output of the airborne receiver. Receipt of the assigned tone code (SELCAL code) activates a light or chime signal in the cockpit of the aircraft.

It is the responsibility of the flight crew to ensure that Gander Radio is informed of the SELCAL code available in the airborne equipment, if they intend to communicate with Gander Radio. This may be done in connection with the “off-ground” report or when transferring in flight from one network to another.

ICAO establishes the standards and procedures for SELCAL in Annex 10 to the *Convention on International Civil Aviation*, Volume II. The worldwide administration of SELCAL code assignments has been delegated to Aviation Spectrum Resources, Inc. (ASRI). SELCAL code application forms may be obtained at: <www.asri.aero/selcal>.

6.5 TELECOMMUNICATIONS AND EN ROUTE FACILITIES SERVICE FEES

A service fee is levied for each international flight in the course of which an aircraft uses air/ground frequencies to obtain telecommunication services. Also, there is a service fee for aircraft flying over the NAT. For details, see FAL 3.0.

6.6 USE OF GENERAL PURPOSE VHF OR SATCOM VOICE IN LIEU OF INTERNATIONAL HF A/G FREQUENCIES

6.6.1 NAT and Anchorage Arctic Regions—SATCOM Voice Use

SATCOM voice may be used to contact Gander Radio for non-routine flight safety calls or during periods of poor HF propagation. Gander Radio may be contacted using Inmarsat short code 431613.

6.6.2 NAT Region—VHF Coverage

VHF FREQUENCIES	
126.9	(45N050W – 51N050W)
126.9 (CYFB)	(61N070W – 67N070W)
127.1	(48N050W – 54N050W)
122.375	(45N050W – 54N050W)
127.9	(57N-63N040W – 57N-61N050W)

NOTE: SELCAL is utilized on all A/G frequencies.

General purpose VHF communications facilities have been provided by Canada, Denmark and Iceland in order to supplement HF radio coverage in the NAT Region. General purpose VHF coverage is shown on the charts following this subsection. It should be noted that:

- (a) charts depict approximate coverage areas only;
- (b) coverage at lower altitudes will be less than depicted; and
- (c) the minimum altitude for continuous VHF coverage across the NAT is considered to be 30 000 ft (see following charts).

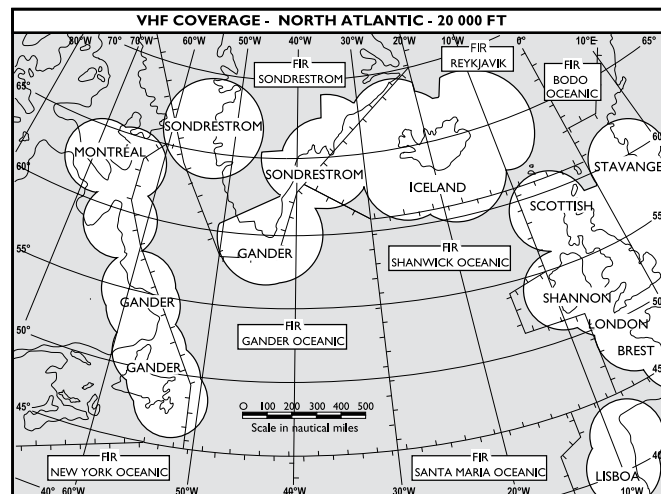
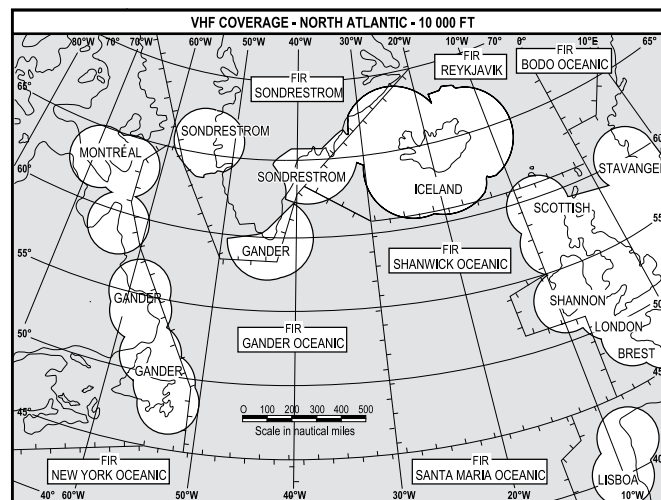

COM

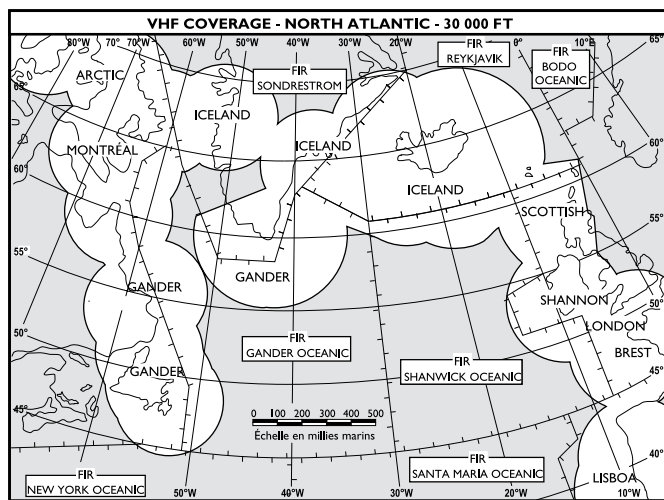

NOTE : Minimum altitude for continuous VHF coverage across the North Atlantic is considered to be 30 000 feet

Several attempts to establish communication may be necessary upon entry into the “fringe area” of reception. Aircraft should maintain SELCAL watch on HF when in fringe areas of VHF coverage. Upon exiting, communication should be re-established on HF channels, preferably before flying beyond normal VHF coverage. Because VHF coverage is limited, aircraft must be equipped with an approved and serviceable HF radio capable of two-way radio communication with ATS from any point along the route during flight.

(See RAC 11.2 and CAR 602.39)

NOTE: Notwithstanding the foregoing, aircraft may proceed across the Atlantic without HF radio subject to the following restrictions:

- (a) below FL195, routing Iqaluit (Frobay) – Sondre Stromfjord – Keflavik; and
- (b) FL250 or above, routing Goose VOR – Prins Christian Sund (or Narsarsuaq) – Keflavik. The aircraft is not allowed to operate in MNPS airspace unless MNPS authority is held.

6.6.3 Canadian Northern Airspace—SATCOM Voice Use

When operating within Canadian northern airspace, SATCOM voice may be used as an alternative to HF for routine communications. The use of SATCOM voice for this purpose requires on board embedded equipment. Permanent satellite voice equipment must be installed and tested in accordance with appropriate certification and airworthiness standards.

Pilots electing to use SATCOM voice must, on initial contact, do a SELCAL check on the assigned HF frequency and continue to maintain a listening watch on that appropriate frequency. Pilots shall, in their first SATCOM voice transmission to Gander Radio, include the word “SATCOM” following the operator’s telephony designator and flight number:

Pilot: *GANDER RADIO, AIR CANADA ZERO TWO ZERO (ACA020) SATCOM, POSITION REPORT.*

Gander Radio: *ACA020 SATCOM, GANDER RADIO, GO AHEAD.*

Pilot: *GANDER, ACA020, (message).*

Gander Radio: *ACA020, GANDER, (readback message, if required).*

Safety-level priority has been assigned to ATS communications by service providers such as Inmarsat. When accepting an incoming call, the pilot shall visually confirm and verify that it is an ATC safety-level priority call. Calls using other priorities delivering ATC instructions shall be disregarded and crews shall contact the ATC unit to confirm the validity of the message received.

To contact Gander Radio by means of SATCOM voice, use the Inmarsat short code 431613 or the public switched telephone network (PSTN) number 1-709-651-5328

6.6.4 Canadian Northern Airspace—VHF Coverage

General purpose VHF communication services from NWS are provided from North Bay (Arctic Radio) and Gander Radio in order to supplement HF radio coverage in the Canadian northern airspace. General purpose VHF coverage is shown below. It should be noted that:

- (a) the chart depicts approximate coverage area only; and
- (b) coverage at lower altitudes will be less than depicted.

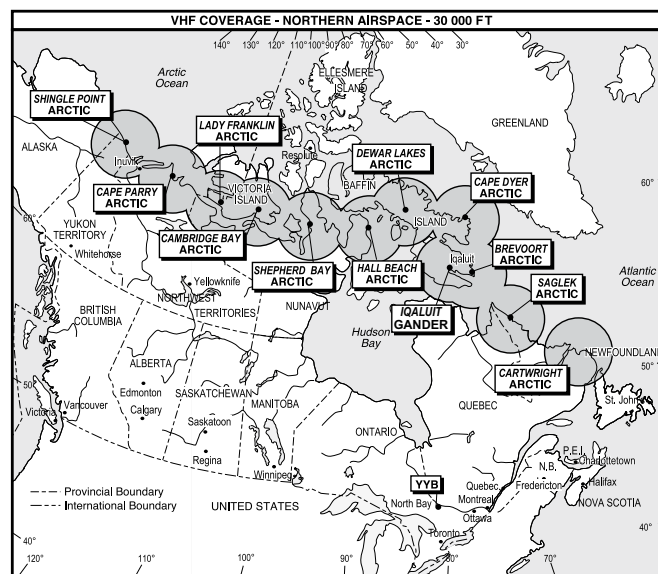

COM

**COM ANNEX A –
RADIO COMMUNICATIONS**

1.0 CANADIAN AVIATION REGULATIONS

Language Used in Aeronautical Radio Communications

602.133

English and French are the languages of aeronautical radio communication in Canada.

Locations Where Services are Available in English and French

602.134

- (1) Any person operating an aircraft who wishes to receive the services referred to in this section in one of either English or French shall so indicate to the appropriate air traffic control unit or flight service station by means of an initial radiocommunication in English or French, as appropriate.
- (2) Every flight service station set out in Table I and every air traffic control unit set out in Table III shall provide advisory services in English and French.
- (3) Every air traffic control unit set out in Table III shall provide air traffic services in English and French.
- (4) Every temporary air traffic control unit located in the province of Quebec shall provide air traffic services in English and French.
- (5) Every flight service station set out in Table II shall provide, between any person operating an aircraft and any air traffic control unit set out in Table III, a relay service of IFR air traffic control messages in English or French, as indicated by that person.

Locations Where Services are Available in English

602.135

All air traffic control units and flight service stations shall provide aeronautical radiocommunication services in English.

TABLE I (Section 602.134)

FLIGHT SERVICE STATIONS WHERE ADVISORY SERVICES ARE AVAILABLE IN ENGLISH AND FRENCH

1.	Gaspé
2.	Gatineau
3.	Îles-de-la-Madeleine
4.	Kuujuaq
5.	Kuujuarapik
6.	La Grande Rivière
7.	Mont-Joli
8.	Montréal
9.	Québec
10.	Roberval
11.	Rouyn
12.	Sept-Îles
13.	Squaw Lake (seasonal station)
14.	Val-d'Or

TABLE II (Section 602.134)

FLIGHT SERVICE STATIONS WHERE RELAY SERVICES OF IFR AIR TRAFFIC CONTROL MESSAGES ARE AVAILABLE IN ENGLISH AND FRENCH

1.	Gaspé
2.	Gatineau
3.	Îles-de-la-Madeleine
4.	Kuujuaq
5.	Kuujuarapik
6.	La Grande Rivière
7.	Mont-Joli
8.	Montréal
9.	Québec
10.	Roberval
11.	Rouyn
12.	Sept-Îles
13.	Squaw Lake (seasonal station)
14.	Val-d'Or

COM

TABLE III (Section 602.134)

AIR TRAFFIC CONTROL UNITS WHERE ADVISORY SERVICES AND AIR TRAFFIC CONTROL SERVICES ARE AVAILABLE IN ENGLISH AND FRENCH

1.	Area Control Centre Montréal
2.	Terminal Control Units Bagotville
3.	Montréal
4.	Ottawa
5.	Québec
6.	Air Traffic Control Towers Bagotville
7.	Montréal International (Dorval)
8.	Montréal International (Mirabel)
9.	Ottawa international/Macdonald-Cartier
10.	Québec/Jean Lesage
11.	St-Honoré
12.	St-Hubert
13.	St-Jean (Province of Quebec)

COM ANNEX B – USE OF PORTABLE PASSENGER- OPERATED ELECTRONIC DEVICES ON BOARD AIRCRAFT

1.0 GENERAL

After reports of interference to aircraft systems caused by portable electronic devices operated on board aircraft, the airline industry requested that the RTCA Inc. conduct an investigation into the problem. In 1988, RTCA Special Committee 156 (SC-156) completed its study of this interference problem and concluded that for interference to occur, at least eight conditions would have to occur simultaneously. These include:

- (a) a portable device radiating over the limit at which receiver disruption can occur;
- (b) a location in the worst-case position in the aircraft cabin (i.e., in a seat with a window near the aircraft antennas);
- (c) the portable device is orientated to maximum peak radiation in direction for minimum path (signal) loss (i.e., normally out the window);
- (d) reflection paths offered by objects outside the aircraft (i.e., wing, control surfaces, etc.);
- (e) the frequency of emission from the portable device falls within the aircraft receiver system operational frequency band;
- (f) the frequency of emission from the portable device falls within the receiver pass band;
- (g) the characteristic of emission is suitable to cause receiver disruption which may or may not be observable by the flight crew; and
- (h) a receiver system is operating at near its minimum signal level.

Because these conditions are independently variable, the RTCA concluded the chances of all occurring simultaneously are very low.

The vulnerability of aircraft radio-navigation and communications systems may be greatest during the takeoff, climb, approach and landing phases of flight. During these phases, the aircraft is at lower altitudes and may be in close proximity to numerous ground-based interference sources, which could increase the likelihood of disruptive interference due to combined interference effects.

COM

1.1 PORTABLE TWO-WAY RADIOCOMMUNICATION DEVICES

Portable two-way radiocommunication devices such as cellular phones are classified as transmitters. Transport Canada Civil Aviation is therefore concerned that passenger use of portable two-way radiocommunication devices on board aircraft may interfere with the safe operation of the aircraft radio navigation/radiocommunication systems and flight management systems.

Portable two-way radiocommunication devices include, but are not limited to, cellular phones, two-way radios, mobile satellite service handsets, personal communications services devices, etc.

NOTE: Radio telephones which are permanently installed in aircraft are installed and tested in accordance with appropriate certification and airworthiness standards. In the context of this document, these devices are not considered portable two-way radiocommunication devices.

2.0 REGULATORY REQUIREMENT

The *Canadian Aviation Regulation* (CAR) 602.08(1) prohibits the use of a portable electronic device on board an aircraft where the device may impair the functioning of the aircraft systems or equipment.

The onus for determining if passenger-operated electronic devices will cause interference is placed on the operator of the aircraft because there are no airworthiness standards for the manufacture of passenger-operated devices, no maintenance standards and no performance standards in relation to their use on an aircraft. It is therefore the responsibility of the operator of the aircraft and/or the pilot to determine if these devices cause interference.

CAR 602.08(2) prohibits a person from using a portable electronic device on board an aircraft except with the permission of the operator of the aircraft.

CAR 703.38, 704.33, and 705.40 require air operators to establish procedures for the use of portable electronic devices on board aircraft that meet the Commercial Air Services Standards (CASS) and are specified in the air operator's company operations manual.

3.0 OPERATING PROCEDURES

Operating procedures have been divided into two categories: Informing Passengers and Interference.

3.1 INFORMING PASSENGERS

CARs 703.39 and 723.39; 704.34 and 724.34; 705.43 and 725.43, and 604.18 and 624.18 require passengers to be informed of the air operator's policy pertaining to the use of electronic devices during the preflight safety briefing.

Although not required to do so by regulatory requirement, we recommend that all other operators inform their passengers accordingly.

Prohibited Devices	Permitted Devices (if demonstrated acceptable) – With Restrictions	Permitted Devices – Without Restrictions
<p>Any transmitting device which intentionally radiates radio frequency signals, such as citizen band (CB) radios and transmitters that remotely control devices such as toys.</p>	<p>(a) <i>Personal Life Support Systems</i>: Personal life support systems may be operated during all phases of flight, provided that these systems will not cause interference with the aircraft systems or equipment.</p> <p>(b) <i>Portable Two-Way Radiocommunication Devices</i>: Passenger use of portable two-way radiocommunication devices on board aircraft is prohibited at all times when the aircraft engines are running, excluding the auxiliary power unit (APU).</p> <p>If the preflight safety briefing and demonstrations begin prior to engine start, use of portable two-way communication devices must be terminated during the delivery of the safety briefing and demonstrations.</p> <p>Passengers may use portable two-way radiocommunication devices if the air operator has established procedures in the Operations Manual (and Flight Attendant Manual, if applicable):</p> <ul style="list-style-type: none"> (i) to inform the passengers when the use of these devices is prohibited, and (ii) to ensure these devices are turned off and properly stowed: <ul style="list-style-type: none"> (A) during the delivery of the preflight safety briefing and demonstrations, and (B) while the aircraft engines are running. <p>(c) <i>Other portable electronic devices</i> may be used except during takeoff, climb, approach and landing. Typically these phases of flight coincide with the “seat belt on” sign and the requirement to stow seat trays;</p> <p>Devices that may be used include, but are not limited to:</p> <ul style="list-style-type: none"> (i) audio or video recorders, (ii) audio or video playback devices, (iii) electronic entertainment devices, (iv) computers and peripheral devices, (v) calculators, (vi) FM receivers, (vii) TV receivers, and (viii) electric shavers. 	<p>The following devices are permitted without any restrictions:</p> <ul style="list-style-type: none"> (a) hearing aids; (b) heart pacemakers; (c) electronic watches; and (d) properly certified operator equipment, such as operator provided passenger air/ground telephone equipment operated in accordance with all other safety requirements.

COM

3.2 INTERFERENCE

In accordance with regulatory requirements, if interference from a portable electronic device is suspected, the operator of the aircraft shall prohibit the use of the device.

It is recommended that all operators implement the following suspected interference procedures and reporting interference procedures:

Procedures – Suspected Interferences	Reporting Interference
<p>Where interference from a portable electronic device is suspected, crew members shall prohibit the use of the suspected device(s) by:</p> <ul style="list-style-type: none"> (a) confirming passenger use of electronic device(s); (b) terminating the use of portable electronic device(s); and (c) rechecking the aircraft electronic equipment 	<p>The operator is responsible for reporting incidents of interference by completing a report form or by providing the following details:</p> <p><i>Flight Information:</i> aircraft type, registration number, date and UTC time of incident, aircraft location (VOR bearing / DIST/LAT/LONG), altitude, weather conditions, pilot name and telephone number.</p> <p><i>Description of Interference:</i> describe effects on cockpit indicators, audio, or systems, including radio frequency, identification, duration, severity and other pertinent information.</p> <p><i>Action Taken by Pilot/Crew to Identify Cause or the Source of Interference.</i></p> <p><i>Identification of Portable Electronic Device:</i> description of device, brand name, model, serial number, mode of operation (i.e., FM radio), device location (seat location), and regulatory approval number (FCC/other).</p> <p><i>Identification of User:</i> the name and telephone number of the passenger operating the device would be beneficial, if the passenger is willing to provide it.</p> <p>Additional Information: as determined by the crew.</p> <p>Reports of interference are to be submitted to:</p> <p style="padding-left: 40px;">Transport Canada (AARQ) Director, Safety Services Ottawa ON K1A 0N8</p> <p>Tel.: 613-990-1280 Fax: 613-991-4280</p>

COM

MET – METEOROLOGY

1.0 GENERAL INFORMATION

1.1 GENERAL

The Minister of Transport is responsible for the development and regulation of aeronautics and the supervision of all matters connected with aeronautics.

The responsibility for the provision of aviation weather services in Canadian airspace, and any other airspace in respect of which Canada has the responsibility for the provision of ATC services, has been designated to NAV CANADA by the Minister of Transport.

NAV CANADA is responsible for a range of aviation weather services, which are provided to it under a contractual agreement with Environment Canada (EC). These services include most civilian aviation weather forecasts. NAV CANADA is responsible for determining the location and frequency of aviation weather observations and forecasts, and for the dissemination of this information for aviation purposes.

In addition to the aviation weather services provided by NAV CANADA, other aviation service providers may offer weather services in support of operations at local aerodromes that have light traffic, are private, and/or are used primarily in support of private industry, such as mining or other similar operations.

The Department of National Defence arranges for the provision of aviation weather services at military aerodromes.

1.1.1 Meteorological Responsibility

Enquiries relating to the provision of aviation weather services should be addressed to NAV CANADA:

NAV CANADA
Aviation Weather Services
77 Metcalfe Street
Ottawa ON K1P 5L6

Tel. Toll-free (North America only):1-800-876-4693
Fax: 613-563-3426
Fax Toll-free (North America only): 1-877-663-6656
E-mail:service@navcanada.ca

Enquiries relating to regulations and standards for aviation weather services should be addressed to:

Aerodromes and Air Navigation Standards (AARTA)
Transport Canada
Ottawa ON K1A 0N8

Tel.: 613-998-9855
Fax: 613-954-1602
E-mail:ron.carter@tc.gc.ca

1.1.2 Meteorological Services Available

Aviation weather information is available from NAV CANADA FICs. Telephone numbers and hours of services are listed in the CFS and the WAS.

1.1.3 Aviation Weather Services

(a) Pilot Briefing Service

The pilot briefing service is provided by NAV CANADA FICs to accommodate pilots at the pre-flight planning stage and for information updates while en route. Flight service specialists can access and display a full range of weather charts, imagery (e.g. satellite, lightning and radar) and aeronautical information (such as NOTAM, RSC and CRFI). They are qualified to provide briefings, consultation and advice, and to interpret meteorological information. (See RAC 3.2 for details).

(b) Aviation Weather Web Site

The NAV CANADA Aviation Weather Web Site (AWWS) includes the following:

- (i) Local briefings: user-selected weather information within a 100-NM radius of any site in Canada that has a surface aviation weather observation program;
- (ii) Regional briefings: user-selected weather information within given regional areas; and
- (iii) Route briefings: user-selected weather information along a user-defined narrow route

In addition to the above, users can individually select all text, chart, and imagery observation and forecast products for display. They can also save regional area and route briefings for subsequent recall. A search engine is available to allow users to search documentation in the database, including FAQs (frequently asked questions). The URL for the AWWS is <www.flightplanning.navcanada.ca/>.

(c) Other Pilot Weather Services

By arrangement with the U.S. National Weather Service, upper level wind and temperature forecasts in digital form are made available to operators in Canada for planning flights on a world-wide basis. Identical information is made available to the Gander Oceanic ATC Centre for planning transatlantic flights.

Aviation weather flight documentation is provided, subject to prior notification, as determined by the local weather service outlet in consultation with the operator's local representative.

Operators requiring user-pay connections to the EC weather communications systems for pre-flight planning, flight documentation or flight watch purposes should apply to the Director General of the National Weather Services Directorate:

MET

Director General
Weather and Environmental Prediction Services
Environment Canada
141 Laurier Avenue West, 2nd floor
Ottawa ON K1A 0H3

It is the responsibility of the operator to notify NAV CANADA, Aviation Weather Services, of new requirements. (See MET 1.1.1 for address.)

1.1.4 Weather Service Information

When planning a flight, pilots can obtain aviation weather and aeronautical information and file a flight plan through a NAV CANADA FIC. (See RAC 3.2 for details).

Radio communication should be established with an FIC on a FISE frequency if in-flight information is required to assist in making a decision or to terminate a flight, or to alter course before adverse weather conditions are encountered.

Pilot requests for initial pilot briefings while airborne are not encouraged because this practice leads to frequency congestion.

1.1.5 Weather Observing Systems and Procedures at Major Aerodromes

ATS procedures require that wind information be transmitted with landing and take-off clearance only when the wind speed is 15 kt or greater.

Major aerodromes are equipped with an anemometer on a 10-m mast, which feeds direct wind instrumentation readings to the local weather observation office and/or ATS units. Wind velocity (direction and speed) data is typically updated every 15 seconds using a running 2-min average. Variations to the wind speed (gusts) and/or wind direction are based on wind data from the previous 10 min.

Information on the cloud-base height is obtained by use of laser ceilometers, ceiling projectors, ceiling balloons, pilot reports and observer estimation. Observations are provided to the local ATS units in the form of METARs and SPECIs.

Temperature is read each hour from a remote readout thermometer. Some stations have thermometers located behind ventilated screens that require manual reading.

RVR observations are obtained by transmissometers and forward-scatter sensors. Observations representative of the touchdown and midpoint visibility averaged over 1 min and based on the light setting in use are automatically displayed in digital form in the local ATS unit. At locations where RVR information is accessible to the weather observer, the RVR is included in METARs and SPECIs when it is 6 000 ft or less for the runway in use and/or the visibility is 1 SM or less. Refer to the METAR example (MET 3.15.3) for further details.

At some locations, a digital altimeter display system is provided in ATS units, as required.

Observations of slant visual range, vertical wind shear, trailing vortices and marked temperature inversions are not made in Canada.

(a) Reporting of Cloud Bases

There are two distinct methods of reporting cloud bases. It is vital to the pilot to be able to distinguish and recognize which method of reporting is in use. Heights in METAR and TAF are always stated as height AGL. On the other hand, heights in graphic area forecasts (GFA) and PIREPs are normally stated as height ASL, since terrain heights are variable over the larger area covered. If heights are not ASL in GFAs, this is always highlighted by statements such as “ST CIGS 24 HND ABV GND”.

(b) Reporting of Ceilings

A ceiling is the lesser of the height above ground or water of the base of the lowest layer of cloud covering more than half the sky or the vertical visibility in a surface-based layer which completely obscures the whole sky.

(c) Sky Conditions

Sky conditions are classified in terms of eighths of sky covered [see MET 3.15.3(k)].

1.1.6 Pilot Reports

PIREP

Pilots are urged to volunteer reports of cloud tops, upper cloud layers, cruising level, wind velocity, and other meteorological information which may be significant to safe or comfortable flight conditions. The information is also used by EC meteorologists to confirm or amend aviation weather forecasts. PIREPs less than 1 hr old that contain information considered to be a hazard to aviation are broadcast immediately to aircraft using the affected area and will be included in subsequent scheduled weather broadcasts. PIREPs are also transmitted on the EC communications system under the headings “UACN10” for normal PIREPs and “UACN01” for urgent PIREPs. A suggested format for PIREPs can be found on the back cover of the CFS and the WAS. More information on PIREP is contained in MET 2.0 and 3.17.

AIREP

Meteorological reports (AIREPs) are appended to the routine position reports of some flights as follows:

- (a) International Air Carrier aircraft transiting Canadian Domestic FIRs north of 60°N and east of 80°W, and north of 55°N and west of 80°W should use the AIREP format and report routine meteorological observations to Gander Radio at each designated reporting point or line;

(b) All aircraft operating in the Gander Oceanic Area should use the AIREP format and report routine meteorological observations at each designated reporting point or line. The exception is that aircraft cleared on a designated NAT track will give these reports only if the phrase “SEND MET REPORTS” is included in their oceanic clearance.

There are no special requirements for transmitting AIREPs with appended meteorological information other than those specified in the ICAO Regional Supplementary Procedures.

1.1.7 Applicable International Civil Aviation Organization (ICAO) and World Meteorological Organization (WMO) Documents

Whereas ICAO determines the standards and recommended practices with respect to meteorological service for international air navigation, the WMO determines and reports the internationally agreed upon code formats for the reports and forecasts. ICAO and WMO documents applicable to aviation meteorology are as follows:

- ICAO Annex 3 — *Meteorological Service for International Air Navigation*
- ICAO Doc 7030 — *Regional Supplementary Procedures*
- ICAO Doc 8755 — *Air Navigation Plan – North Atlantic, North American and Pacific Regions*
- WMO Doc 306 — *Manual on Codes*

WMO documents may be ordered directly from the WMO Secretariat in Geneva, Switzerland. ICAO documents may be purchased from the ICAO Headquarters in Montréal. The two relevant addresses are listed below:

- Publications Sales & Distribution (PubSales)
World Meteorological Organization
P.O. Box 2300
CH-1211 Geneva 2
Switzerland
Tel.: 00 41 22 730 85 84 / 00 41 22 730 84 26
Fax: 00 41 22 730 80 22
- ICAO
Distribution Sales Unit
Suite 305
999 University Street
Montréal QC H3C 5H7
Tel.:514-954-8026

Pilots flying outside of North America should consult the differences filed by other member states as outlined in WMO Doc. 306 or in the AIP of each country.

1.1.8 Differences from ICAO Annex 3

CAR 804.01(1)(a) incorporates standards contained in ICAO’s Annex 3 to the *Convention on International Civil Aviation— Meteorological Service for International Air Navigation*. The current version of Annex 3 includes Amendment 75, which became applicable on November 18, 2010, and will remain in effect until November 2013. In accordance with CAR 800.01(2) the incorporation of Annex 3 as a standard includes the differences notified to ICAO by the Government of Canada in respect of the standards specified in that annex. The full details of these State differences are included in the *AIP Canada (ICAO)*, as published and disseminated by NAV CANADA.

1.1.9 Pilot Responsibility

Pilots must be aware of the requirements of CAR 602.72: “The pilot-in-command of an aircraft shall, before commencing a flight, be familiar with the available weather information that is appropriate to the intended flight.”

1.2 METEOROLOGICAL OBSERVATION AND REPORTS

1.2.1 Aeronautical Meteorological Stations and Offices

The location of meteorological stations and offices is contained in CFS and in MET 3.1.

1.2.2 Type and Frequency of Observations

Aviation routine weather reports (METAR) are coded weather observations that are taken each hour at over 200 aerodrome and other locations in Canada. In addition, special weather reports (SPECI) are issued whenever weather conditions fluctuate about or are below specified criteria. See MET 3.15.3 for the contents and decode instructions for these reports.

METAR and SPECI are taken 24 hours per day at all international aerodromes.

The location of transmissometers or forward scatter sensors used to determine Runway Visual Range is specified in the CAP aerodrome Charts.

Information is available to ATS unit(s) by connections to the EC communications system. Current information with respect to surface wind, Runway Visual Range and altimeter setting is provided by the Operational Information Display System and the Digital Altimeter Display System. At locations where these facilities are not available, altimeter setting indicators and duplicate read-outs of surface wind speed and direction are provided.



1.2.3 Flight Weather Documentation

Pilots must ensure that all weather information used for flight-planning purposes is the most recent information available, and must be aware of when more routinely scheduled weather updates will become available. Pilots must also remain vigilant for pertinent unscheduled weather updates or amendments.

Flight weather documentation is provided in the form of copies of aviation area forecasts, in chart form, together with copies of alphanumeric aerodrome forecasts, and upper wind and temperature forecasts.

1.2.4 Automated Weather Observation System

An automated weather observation system (AWOS) comprises a set of meteorological sensors, a data processing system, a communications system and an optional voice generator module (VGM) and VHF transmitter. AWOS collects meteorological data and disseminates METARs and SPECIs.

Any AWOS that is used for civil aviation purposes must either be the EC-developed system or a commercial AWOS that has been approved by TC for aviation use.

At a minimum, an aviation-approved AWOS is equipped with sensors to report the following:

- wind (direction, speed and gusts);
- altimeter setting (these sensors have a fail-safe design);
- air temperature;
- dew point;
- visibility;
- cloud height;
- sky coverage (of detected cloud);
- precipitation occurrence and type;
- total precipitation;
- and icing.

NOTE: For a complete explanation of the weather reports that are disseminated by AWOS units, please refer to MET 3.15.5.

1.2.5 LWIS

An LWIS comprises automated meteorological sensors, a data processing system, a communication system and an optional voice generator sub-system (VGSS) with VHF transmitter. The LWIS collects limited meteorological data that is transmitted from the site hourly to ATS facilities or every minute to the affiliated VGSS and VHF transmitter unit.

Any LWIS used for civil aviation purposes must comply with TC requirements and be equipped with sensors to report, at a minimum, the following:

- wind (direction, speed and gusts);
- altimeter setting (these sensors have a fail-safe design);
- air temperature; and
- dew point.

Some private LWIS may report additional elements, but have limitations compared to the capabilities of an AWOS. However, hourly reports from these systems may not be available. Persons requiring full details of the performance of a private LWIS should contact the aerodrome operator.

Except for the DND stations in the High Arctic that do not provide dew point information, any automated system that reports fewer elements than the standard four required for an LWIS should not be referred to as an LWIS.

1.2.6 Weather Services in Support of Approach UNICOM (AU)

Weather information is not useable for instrument procedures unless it complies with the requirements of CAR 804 or a related national exemption.

AU is an air-ground communications service that can provide approach and landing information to IFR pilots. The altimeter setting and wind reports provided by an AU are useable in support of the conduct of an instrument procedure. Pending revisions to the CARs, these services must be provided in accordance with one of the two national exemptions to CAR 804.01(1)(c) that is in effect for these services.

The first national exemption establishes how two aircraft altimeters can be used to observe and report a useable altimeter setting. The second establishes procedures to follow for the human assessment of wind speed and direction, useable for the selection of the most into-wind runway. More details regarding these exemptions can be found on the TC Web site or obtained from a regional TC office.

At a few AU locations, fully automated systems are used to measure atmospheric pressure. This data is used to determine the altimeter setting that is relayed to pilots. In these cases, the reported altimeter setting must comply with the same requirements applied to the altimeter component of an LWIS or AWOS.

Any weather information provided by a UNICOM, as opposed to an AU, is not useable for instrument procedures; alternative uses are entirely at the pilot's discretion.

1.2.7 Runway Visibility Assessment (RVA)

At aerodromes where RVR is not provided, qualified persons may, in accordance with the requirements of the runway visibility assessment standards referenced by CAR 804, provide an assessment of runway visibility. Instrument-rated pilots may also provide such assessments in accordance with CAR 602.131.

An RVA is valid for only 20 min after it has been established.

1.3 METEOROLOGICAL FORECASTS AND CHARTS

1.3.1 Locations

The location and indicators are listed in CFS and in MET 3.0.

1.3.2 Hours of Service and Telephone Numbers of FICs

All FICs provide 24-hour service. Telephone numbers of FICs are provided in the CFS. Pilots dialing the common toll-free number 1-866-WXBRIEF (992-7433) will automatically be routed to the FIC serving the area from which the call is being made.

1.3.3 World Area Forecast System (WAFS) Charts

WAFS aviation weather charts are disseminated as required. These include prognostic significant weather charts for the North Pacific, the Caribbean and northern South America, the North Atlantic, Canada and the United States.

Aviation area forecasts are available at all regular international aerodromes for continental United States excluding Alaska, air routes from North America to Europe, Canada and the Arctic Ocean, air routes between North America and the Caribbean, air routes from the west coast of North America to Japan, and air routes from the west coast of North America to Hawaii.

1.3.4 Aerodrome Forecasts

Aerodrome forecasts (TAF) are prepared for approximately 180 aerodromes across Canada (see MET 3.8). TAFs are limited to aerodromes for which METAR and SPECI reports are available. The forecasts are generally prepared four times daily with periods of validity up to a maximum of 30 hr. See MET 3.9 for more information on TAFs, including when they are issued, their periods of validity and decoding instructions.

TAFs are issued in TAF code, with amendments as required.

Aerodrome Advisory Forecasts

Aerodrome advisories are issued in the place of full TAFs when:

- Offsite: the forecast is based on observations that have been taken offsite and are not considered to be representative of weather conditions at the aerodrome;
- Observation Incomplete: the forecast is based on observations which have regularly-missing or incomplete data; or
- No Specials: the forecast is based on observations from a station with a limited observing program that does not issue SPECI reports.

In each case, after the period of coverage group, the advisory forecast will be labelled with the word “ADVISORY” and the appropriate qualifier (OFFSITE, OBS INCOMPLETE, or NO SPECI).

1.3.5 Weather Information

(a) PATWAS

To serve identified, repetitive information demands, a continuous recording of some local aviation weather information from FICs is accessible by telephone. The locations of this service are identified in CFS and WAS. PATWAS recordings will normally include:

- location indicator and introduction,
- instructions,
- SIGMETs,
- AIRMETs,
- METAR and SPECI reports for selected stations,
- aerodrome forecasts (TAF) for selected stations,
- forecast winds and temperatures aloft (FD),
- icing, freezing level and turbulence,
- selected PIREPs, and
- daily sunrise and sunset times.

Portions of the PATWAS recording are typically accessed by using an appropriate touch-tone number once a telephone connection to the system has been made. At the present time, PATWAS recordings must be manually updated; they may not, therefore, reflect the most current weather information available if conditions are changing rapidly.

(b) Coastal Weather

Float plane operators can also obtain coastal marine weather on HF and VHF-FM frequencies from some Canadian Coast Guard stations. Frequencies and time of broadcast are contained in two Canadian Coast Guard Publications – Radio Aids to Marine Navigation (Pacific, and Atlantic and Great Lakes). These two publications are published annually and are available from the Canada Communication Group – Publishing (see MAP 7.2 for addresses and prices).

1.3.6 Area Forecasts and AIRMET

Graphic area forecasts (GFA) are issued as a series of temporally adjusted weather charts for Canadian Domestic Airspace and distributed on a routine or on-request basis. These forecasts are prepared four times daily for 7 regions across the country with a coverage period of 12 hours and an outlook for a further 12 hours. See MET 3.3 for issue, periods of coverage and decoding instructions. Amendments to area forecasts are known as AIRMETs. A full description of this product can be found in MET 3.4.

1.3.7 Upper Level Wind and Temperature Forecasts

Alphanumeric upper level wind and temperature forecasts (FD) are routinely prepared for 142 sites in Canada. FD forecasts are produced by a super-computer model of the atmosphere called a Numerical Weather Prediction (NWP) model (NWP model for short), which is run twice per day (00Z, and 12Z) after ingesting weather observation data from around the world.

An FD forecast based on the 12Z NWP model run on the fifth day of the month would include the following text at the top of the forecast data, “FCST BASED ON 051200 DATA”. The text “DATA VALID 060000” in the FD forecast indicates that the temperature and wind velocity data is forecast to be most representative of conditions at 00Z on the sixth day of the month. FD forecast data can be used for several hours either side of the stated valid time. This is indicated by the text “FOR USE 21 – 06”, which means that this particular forecast may be used for a 9-hour period from 21Z to 06Z.

During flight planning, care must be exercised to ensure that the correct FD forecast is selected and the associated “FOR USE” coverage is appropriate for the time of the proposed flight.

1.3.8 ATC Weather Assistance

ATC will issue information on significant weather and assist pilots in avoiding weather areas when requested. However, for reasons of safety, an IFR flight must not deviate from an assigned course or altitude/flight level without a proper ATC clearance. When weather conditions encountered are so severe that an immediate deviation is determined to be necessary, and time will not permit approval by ATC, the pilot’s emergency authority may be exercised. However, when such action is taken, ATC should be advised as soon as practicable of the flight alteration.

When a pilot requests clearance for a route deviation or for an ATC radar vector, the controller must evaluate the air traffic situation in the affected area and co-ordinate with other controllers before replying to the request when ATC operational boundaries have to be crossed.

It should be remembered that the controller’s primary function is to provide safe separation between aircraft. Any additional service, such as weather avoidance assistance, can only be provided to the extent that it does not detract from the primary function. Also note that the separation workload for the controller generally increases when weather disrupts the usual flow of traffic. ATC radar limitations and frequency congestion is also a factor in limiting the controller’s capability to provide additional services.

It is important, therefore, that the request for a deviation or radar vector be forwarded to ATC as far in advance as possible. Delay in submitting it may delay or even preclude ATC approval or require that additional restrictions be placed on the clearance. Pilots should respond to a weather advisory by requesting: a deviation off course and stating the estimated

number of miles and the direction of the requested deviation; a new route to avoid the affected area; a change of altitude; or, radar vectors around the affected areas.

The following information should be given to ATC as early as possible when requesting clearance to detour around weather activity:

- (a) proposed route and extent of detour (direction and distance);
- (b) flight conditions IMC or VMC; and
- (c) advise if the aircraft is equipped with a functioning cockpit weather radar.

The assistance that might be given by ATC will depend upon the weather information available to controllers. Owing to the often transitory nature of severe weather situations, the controller’s weather information may be of only limited value if based on weather observed on radar only. Frequent updates by pilots, giving specific information as to the area affected, altitudes, intensity and nature of the severe weather, are of considerable value. Such PIREPs receive immediate and widespread dissemination to aircrew, dispatchers and aviation forecasters.

1.3.9 Supplementary Information

Weather Radar

Weather radars typically present a display of precipitation within 150 NM of the facility site; storms of considerable height and intensity can be seen at greater ranges. However, it should be noted that these radars cannot detect turbulence. The turbulence associated with a very heavy rate of rainfall will generally be significantly more severe than that associated with light rainfall.

Environment Canada (EC) and the Department of National Defence (DND) operate a series of weather radars across Canada that provide frequent reports of precipitation echo tops and precipitation reflectivity. Radar images are updated approximately every 10 min for individual radars. A colour composite radar product, which depicts either echo tops or precipitation reflectivity is also available on the flight planning section of NAV CANADA’s Web site. The colour composite is not a real-time depiction as the product is 40 min old when issued and is only updated every 40 min.

1.4 VOLMET

1.4.1 General

The VOLMET is meteorological information for aircraft in flight, particularly those over the high seas. The VOLMET contains METARs and aerodrome forecasts (TAF) for selected aerodromes and may be provided either by data link (D-VOLMET) or by voice broadcasts on designated frequencies, normally high frequency (HF).

Information on the content, issue times and transmitter frequencies for North Atlantic VOLMET broadcasts is given in the CFS, Section “D”, Radio Navigation and Communications.

2.0 PILOT REPORTS

2.1 GENERAL

A PIREP is a report pertaining to current weather conditions encountered in flight. It is designed to provide other pilots, dispatchers and weather briefers with up-to-the-minute weather information. In addition, it is an invaluable data source for aviation meteorologists because it either confirms an existing forecast or highlights the requirement for an amendment. A PIREP may also be the only information available regarding areas between reporting stations, particularly those areas whose topography may produce localized weather phenomena (e.g. hills or expanses of water).

Pilots are encouraged to report conditions that differ significantly from those that were forecast. PIREPs that contain critical information on low clouds, reduced visibility, icing, and convective activities such as wind shear, squall line, turbulence, thunderstorms and cumulonimbus clouds are especially useful. PIREPs of hazardous conditions may trigger the issuance of a SIGMET.

For timely distribution, PIREPs should be filed with a flight information centre (FIC) via an en-route frequency or by a toll-free call to an FIC after landing.

Controllers, flight service specialists and CARS observer/communicators may request reports from pilots regarding specific weather conditions or weather conditions encountered during en-route, climb-out or approach phases.

The CFS contains the toll-free FIC telephone numbers in the Flight Planning section of each listed aerodrome, and the recommended contents of a PIREP are listed on the back cover.

2.2 CLEAR AIR TURBULENCE

Clear air turbulence (CAT) remains a problem for flight operations particularly above 15 000 feet. The best information available on this phenomenon is still obtained from PIREPs, since a CAT forecast is generalized and covers large areas. All pilots encountering CAT conditions are requested to urgently report the time, location, flight level and intensity (light, moderate, severe, or extreme) of the phenomena to the facility with which they are maintaining radio contact. (See Turbulence Reporting Criteria Table, MET 3.7.) A more complete description of CAT and recommended pilot actions can be found in AIR 2.10.

2.3 WIND SHEAR

Intense down drafts, typically associated with thunderstorms, produce strong vertical and horizontal wind shear components that are a hazard to aviation for aircraft in the approach, landing or takeoff phase of flight (see AIR 2.8). Since ground-based instruments to measure wind shear have not been installed at Canadian aerodromes, the presence of such conditions can normally be deduced only from PIREPs.

Aircrew capable of reporting the wind and altitude, both above and below the shear layer, from Flight Management Systems (FMS) are requested to do so. Pilots without this equipment should report wind shear by stating the loss or gain of airspeed and the altitude at which it was encountered. Pilots not able to report wind shear in these specific terms should do so in terms of its general effect on the aircraft.

2.4 AIRFRAME ICING

Report icing to ATS and, if operating IFR, request a new routing or altitude if icing will be a hazard. Give your aircraft identification, type, location, time (UTC), intensity of icing, type, altitude or flight level, and indicated airspeed. (See the suggested format on the back cover of the CFS.)

The following describes icing and how to report icing conditions:

INTENSITY	ICE ACCUMULATION
Trace	Ice becomes perceptible. The rate of accumulation is slightly greater than the rate of sublimation. It is not hazardous, even though de-icing or anti-icing equipment is not used, unless encountered for an extended period of time (over 1 hour).
Light	The rate of accumulation may create a problem if flight is prolonged in this environment (over 1 hour).
Moderate	The rate of accumulation is such that even short encounters become potentially hazardous, and use of de-icing or anti-icing equipment or diversion is necessary.
Severe	The rate of accumulation is such that de-icing or anti-icing equipment fails to reduce or control the hazard. Immediate diversion is necessary.
*Rime ice:	Rough, milky, opaque ice formed by the instantaneous freezing of Small supercooled water droplets.
*Clear ice:	Glossy, clear, or translucent ice formed by the relatively slow freezing of large supercooled water droplets.

*Types of icing

2.5 VOLCANIC ASH

Flight operations in volcanic ash are hazardous (see AIR 2.6). Pilots may be the first line of volcanic eruption detection in more remote areas. Pilots may be able to provide valuable information about the spread of volcanic ash from an eruption; ash can rapidly rise to altitudes above 60 000 feet and exist at hazardous concentrations up to 1 000 NM from the source. Volcanic ash is not detectable on radar. If an eruption or ash cloud is detected, an urgent PIREP should be filed with the nearest ATS unit.

A volcanic ash forecast chart is produced when required (see MET 3.21).

2.6 PILOT ESTIMATION OF SURFACE WIND

Surface wind direction and speed is information critical to effective pilot decision making for takeoff and landing. Where neither wind measuring equipment nor a wind direction indicator (see AGA 5.9) is available, the wind direction and speed can be estimated by observing SMOke, dust, flags or wind lines on bodies of water.

Pilots on the ground may estimate wind speed and direction by using anything that is free to be moved by the influence of the wind. The descriptions in the Beaufort Wind Scale found in Table 1 have been found to be particularly useful and are widely used.

Wind direction can also be estimated accurately by simply facing the wind. Such estimates should only be provided to the nearest eight points (i.e., north, northeast, east) of the compass. The best estimate is obtained by standing in an open area clear of obstructions. Should this not be possible, estimation errors may be so large that pilots using the information should exercise caution. The direction and speed of low-lying clouds can be an indicator of surface winds but should also be used with caution because of the possibility of wind shear near the surface.

Pilots who relay reports of winds based on estimation should ensure that the intended user of the information is aware that it is based on estimation so that appropriate precautions can be taken.

Estimating Wind Speed

The speed may be estimated by using the Beaufort Scale of Winds, which relates common effects of the wind and equivalent speeds in knots.

Table 1: Beaufort Wind Scale

Descriptive Term	Beaufort Force	Speed Range (knots)	Knots Average	Specification for estimating wind over land	Specification for estimating wind over sea (probable wave height in metres*)
Calm	0	Less than 1		Smoke rises vertically	Sea is like a mirror (0)
Light Air	1	1–3	2	Direction of wind shown by Smoke	Ripples with the appearance of scales are formed, but with out foam crest (0.1)
Light Breeze	2	4–6	5	Wind felt on face; leaves rustle; ordinary vane moved by wind	Small wavelets, still short but more pronounced; crests have a glassy appearance and do not break (0.2 to 0.3)
Gentle Breeze	3	7–10	9	Leaves and Small twigs in constant motion; wind extends light flag	Large wavelets; crests begin to break; foam of glassy appearance; perhaps scattered white horses (0.6 to 1)
Moderate Breeze	4	11–16	14	Raises dust and loose paper; Small branches are moved	Small waves becoming longer; fairly frequent white horses (1 to 1.5)
Fresh Breeze	5	17–21	19	Small trees in leaf begin to sway; crested wavelets form on inland waters	Moderate waves, taking a more pronounced long form; many white horses are formed, chance of some spray (2 to 2.5)
Strong Breeze	6	22–27	25	Large branches in motion; whistling heard in telephone wires; umbrellas used with difficulty	Large waves begin to form; the white foam crests are more extensive everywhere, probably some spray (3 to 4)
Near Gale	7	28–33	31	Whole trees in motion; inconvenience felt in walking against wind	Sea heaps up and white foam from breaking waves begins to be blown in streaks along the direction of the wind (4 to 5.5)
Gale	8	34–40	37	Breaks twigs off trees; generally impedes progress	Moderately high waves of greater length; edges of crests begin to break into the spindrift; the foam is blown in well-marked streaks along the direction of the wind (5.5 to 7.5)
Strong Gale	9	41–47	44	Slight structural damage occurs to roofing shingles, TV antennae, etc.	High waves; dense streaks of foam along the direction of the wind; crests of waves begin to topple, tumble and roll over; spray may affect visibility (7 to 10)
Storm	10	48–55	52	Seldom experienced inland; trees uprooted; considerable structural damage	Very high waves with long, overhanging crests; the resulting foam, in great patches, is blown in dense white streaks along the direction of the wind; on the whole, the surface of the sea takes on a white appearance; the tumbling of the sea becomes heavy and shock-like; visibility affected (9 to 12.5)
Violent Storm	11	56–63	60	Very rarely experienced; accompanied by widespread damage	Exceptionally high waves (small and medium sized ships might be lost to the view behind the waves); the sea is completely covered with long white patches of foam lying along the direction of the wind; everywhere the edges of the wave crests are blown into froth; visibility affected (11.5 to 16)
Hurricane	12	Above 63			The air is filled with foam and spray; sea completely white with driving spray; visibility seriously affected (16+)

* Wave height is representative of conditions well away from shore and in deep water when winds of that strength have persisted for an extended period of time. The wave height figure does not give the maximum wave height nor does it take into account the effects of swell, air temperature or currents.

3.0 APPENDICES

3.1 LOCATION OF CANADIAN WEATHER CENTRES

There are now only two Weather Centres (Aviation Forecast) in Canada and they are located in Edmonton, Alberta, and in Montréal, Quebec.

3.2 CANADIAN WEATHER INFORMATION

3.2.1 Aviation Forecasts and Charts

ITEM AND TYPE DESIGNATOR	TIME ISSUED	TIMES OR PERIODS OF COVERAGE	APPLICABLE LEVEL	REMARKS
Area Forecast Charts (GFA)	Approximately 30 min before the beginning of the forecast period	0000Z, 0600Z, 1200Z, 1800Z. Each new set of GFA charts replace preceding ones.	Below 24 000 ft	Graphically depicts forecast weather elements affecting flight at a specific time over a particular area.
Aerodrome Forecast (TAF)	Approximately 30 min before the beginning of the validity period	Forecasts are generally issued every 6 hr with validity periods up to a maximum of 30 hr. Issue and update periods may vary—check the CFS. Next issue time is stated at the end of each TAF.	Surface (includes clouds at levels that can be seen from the surface)	Provides expected conditions for LANDING AND TAKEOFF at specific aerodromes.
Significant Meteorological Information (SIGMET) WSCN, WCCN, WVCN	A short-term weather warning issued when hazardous conditions occur or are expected to occur.			
Upper Level Wind and Temperature Forecast (FD)	0320Z* 0330Z* 0720Z* 1520Z** 1530Z** 1920Z**	0500Z–0900Z 0900Z–1800Z 1800Z–0500Z 1700Z–2100Z 2100Z–0600Z 0600Z–1700Z	3 000 ft 6 000 ft 9 000 ft 12 000 ft 18 000 ft	Predicts upper winds and temperatures in numerical form at standard levels for a given time period and location.
	0440Z 0440Z 0440Z 1640Z 1640Z 1640Z	0500Z–0900Z 0900Z–1800Z 1800Z–0500Z 1700Z–2100Z 2100Z–0600Z 0600Z–1700Z	24 000 ft 30 000 ft 34 000 ft 39 000 ft 45 000 ft 53 000 ft	Upper level wind and temperature forecasts are issued by world area forecast centres (WAFc).
Amended Forecast	Forecasts will be amended when significant changes in ceiling or visibility occur, or when freezing precipitation begins, or is expected to occur, although it was not previously predicted.			
Upper Level Forecast Chart –PROG	12 hr before valid time	0000Z 0600Z 1200Z 1800Z	FL240 FL340 FL390 FL450	Depicts forecast wind and temperatures for the chart level.

MET

ITEM AND TYPE DESIGNATOR	TIME ISSUED	TIMES OR PERIODS OF COVERAGE	APPLICABLE LEVEL	REMARKS
Significant Weather Forecast Chart –PROG	12 hr before valid time	0000Z 0600Z 1200Z 1800Z	FL100–FL240 FL250–FL630	Charts are for a specific flight level range. They indicate surface positions of lows and highs and any significant weather, such as thunderstorms, turbulence and mountain waves, applicable to the chart.

* based on upper atmosphere observations taken at 0000Z.

** based on upper atmosphere observations taken at 1200Z.

3.2.2 Aviation Weather Reports

ITEM AND TYPE DESIGNATOR	TIME OBSERVED	TIME ISSUED	REMARKS
Aviation Routine Weather Report METAR	Every hour on the hour	At once	Describes actual weather at a specific location and at a specific time as observed from the ground. Specials are issued when required. "METAR is not available 24 hours a day at all aerodromes; see CFS for observation program schedule."
Pilot Report (PIREP) UA	As reported		Observations of actual conditions reported by pilots during flight.
Volcanic Ash Report FV	As required	At once	Describes in graphical format the current and expected ash cloud dispersion and densities at various flight levels.

3.2.3 Weather Charts

ITEM AND TYPE DESIGNATOR	TIME OBSERVED	TIME ISSUED	REMARKS
Surface Weather Chart	0000Z 0600Z 1200Z 1800Z	2 or 3 hours after observation	Analysis of MSL pressure pattern, surface location of fronts, surface precipitation and obstructions to vision based on reports. Surface pressure patterns can be considered as representative of the atmosphere up to 3 000 ft. Weather visible from the surface at any level is included.
Upper Level Chart - ANAL	0000Z 1200Z	Over 3 hours after observation	Charts prepared for following levels: 850 mb (1 500 m / 5 000 ft) 700 mb (3 000 m / 10 000 ft) 500 mb (5 500 m / 18 000 ft) 250 mb (10 400 m / 34 000 ft) Charts show reported atmospheric conditions at the pressure levels, such as wind speed and direction, temperatures, and moisture content.

METAR

3.3 GRAPHIC AREA FORECAST (GFA)

3.3.1 General

The GFA consists of a series of temporally adjusted weather charts, each depicting the most probable meteorological conditions expected to occur below 400 mb (24 000 ft) over a given area at a specified time. The GFA is primarily designed to meet general aviation and regional airline requirements for pre-flight planning in Canada.

3.3.2 Issue and Valid Times

GFA charts are issued four times daily, approximately 30 min before the beginning of the forecast period. The GFA is issued at approximately 2330, 0530, 1130 and 1730 UTC and is valid at 0000, 0600, 1200 and 1800 UTC respectively. Each issue of the GFA is really a collection of six charts; two charts valid at the beginning of the forecast period, two charts valid six hours into the forecast period and the final two charts valid twelve hours into the forecast period. Of the two charts valid at each of the three forecast periods, one chart depicts clouds and weather while the other chart depicts icing, turbulence and freezing level. An IFR outlook for an additional twelve-hour period will also be included in the final clouds and weather chart.

3.3.3 Coverage Area

There are seven distinct GFA areas, covering the entire CDA, over which Canada is responsible for the provision of ATC services. The following map illustrates the GFA coverage areas.

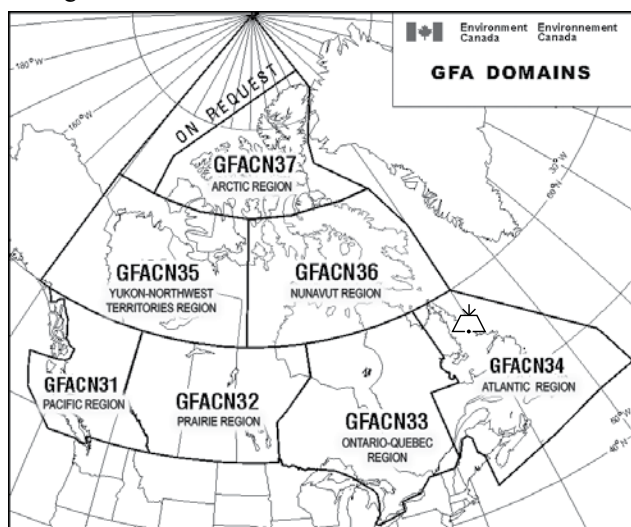

3.3.4 Units of Measure

Speeds in the GFA are expressed in knots (kt) and heights in hundreds of feet. Horizontal visibility is measured in statute miles (SM) and all times are stated in Co-ordinated Universal Time (UTC). A nautical-mile (NM) scale bar is included to assist in determining approximate distances on the chart. All heights are measured above sea level (ASL) unless otherwise noted.

3.3.5 Abbreviations and Symbols

Only standard meteorological abbreviations are used in the GFA. Symbols used in the GFA are consistent with those found on similar meteorological products already described in the *TC AIM*, such as significant weather prognostic charts (MET 3.14). The following is a list of common weather symbols that may be found on the GFA.

	TS	– Thunderstorm
	PL	– Ice Pellets
	FZRA	– Freezing Rain
	FZDZ	– Freezing Drizzle

3.3.6 Layout

Each GFA chart is divided into four parts: title box; legend box; comments box; and weather information section.

Weather Information Section	Title Box
	Legend Box
	Comments Box

3.3.7 Title Box

The title box includes the chart name, issuing office four-letter identification, name of the GFA region, chart type, the date/time of issue, and the valid date/time of the chart. The title box is found at the upper right corner of the GFA.

In the following example, the title box indicates the GFA name (GFACN33) and that it is issued by the Canadian Meteorological Centre in Montréal (CWUL). The GFA region for the sample chart is ONTARIO–QUÉBEC and the type of chart is the clouds and weather chart. The next section indicates the issue time of the GFA chart, which is 1130 UTC on September 17, 1999. The last section states the valid time for the GFA chart which, in this example, is 0000 UTC on September 18, 1999.

GFACN33 CWUL REGION ONTARIO–QUÉBEC CLOUDS AND WEATHER NUAGES ET TEMPS	
ISSUED AT ÉMIS A	17/09/1999 1130Z
VLD:	18/09/1999 0000Z

MET

3.3.8 Legend Box

The legend box includes weather symbols that may be used in the weather information part of the GFA chart. It also includes a nautical-mile scale bar to facilitate the determination of distances. Symbols used in the GFA are consistent with those used in a significant weather prognostic chart. In the following example, symbols for thunderstorm (TS), ice pellets (PL), freezing rain (FZRA) and freezing drizzle (FZDZ) are indicated in the legend box.

LEGEND/LÉGENDE



: TS



: PL



: FZRA



: FZDZ

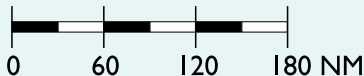

0 60 120 180 NM
(True at 60°N Vrai à 60°N)

3.3.9 Comments Box

The comments box provides information that the weather forecaster considers important (e.g., formation or dissipation of fog, increasing or decreasing visibility). It is also used to describe elements that are difficult to render pictorially or, if added to the depiction, would cause the chart to become cluttered (e.g., light icing). The standard phrases “HGTS ASL UNLESS NOTED” and “CB TCU AND ACC IMPLY SIG TURBC AND ICG. CB IMPLIES LLWS” are also included in the comments box. An IFR outlook for an additional 12-hr period is included in the comments box of the 12-hr GFA clouds and weather chart.

COMMENTS/COMMENTAIRES

1. FG/BR DS IPTG AFT 14Z
2. SC CIGS BECMG SCT AFT 15Z

HGTS ASL UNLESS NOTED CB TCU AND ACC IMPLY SIG TURBC AND ICG. CB IMPLIES LLWS



Environment Canada
Environnement Canada

IFR OTLK

IFR CIG/RA/BR S STLAWRC VLY. LCL IFR IN ONSHR/UPSLP NWLY FLO OFF JMSBA AND HSNBA.

In this example, the forecaster has added two comments. The first indicates that the Fog/Mist will dissipate after 1400 UTC. The second comment advises that stratocumulus ceilings will become scattered after 1500 UTC.

The comments box of the 12-hr clouds and weather GFA chart also includes an IFR outlook for an additional 12-hr period in the lower section of the box. The IFR outlook is

always general in nature, indicating the main areas where IFR weather is expected, the cause for the IFR weather and any associated weather hazards. In the example given, IFR conditions caused by low ceilings (CIG), rain (RA) and mist (BR) south of the St. Lawrence Valley are forecast. Also, local IFR conditions are forecast because of an onshore (ONSHR) and upslope (UPSLP) northwesterly flow of air from James Bay (JAMSBA) and Hudson’s Bay (HSNBA).

For meteorological purposes, the IFR outlook is based on the following:

CATEGORY	CEILING	VISIBILITY	
IFR	less than 1 000 ft AGL	and/or	less than 3 SM
MVFR	between 1 000 ft and 3 000 ft AGL	and/or	between 3 and 5 SM
VFR	more than 3 000 ft AGL	and	more than 5 SM

3.3.10 Weather Information

The weather information part of the chart depicts either a forecast of the clouds and weather conditions or a forecast of the icing, turbulence and freezing level conditions for a specified time.



3.3.11 Clouds and Weather Chart

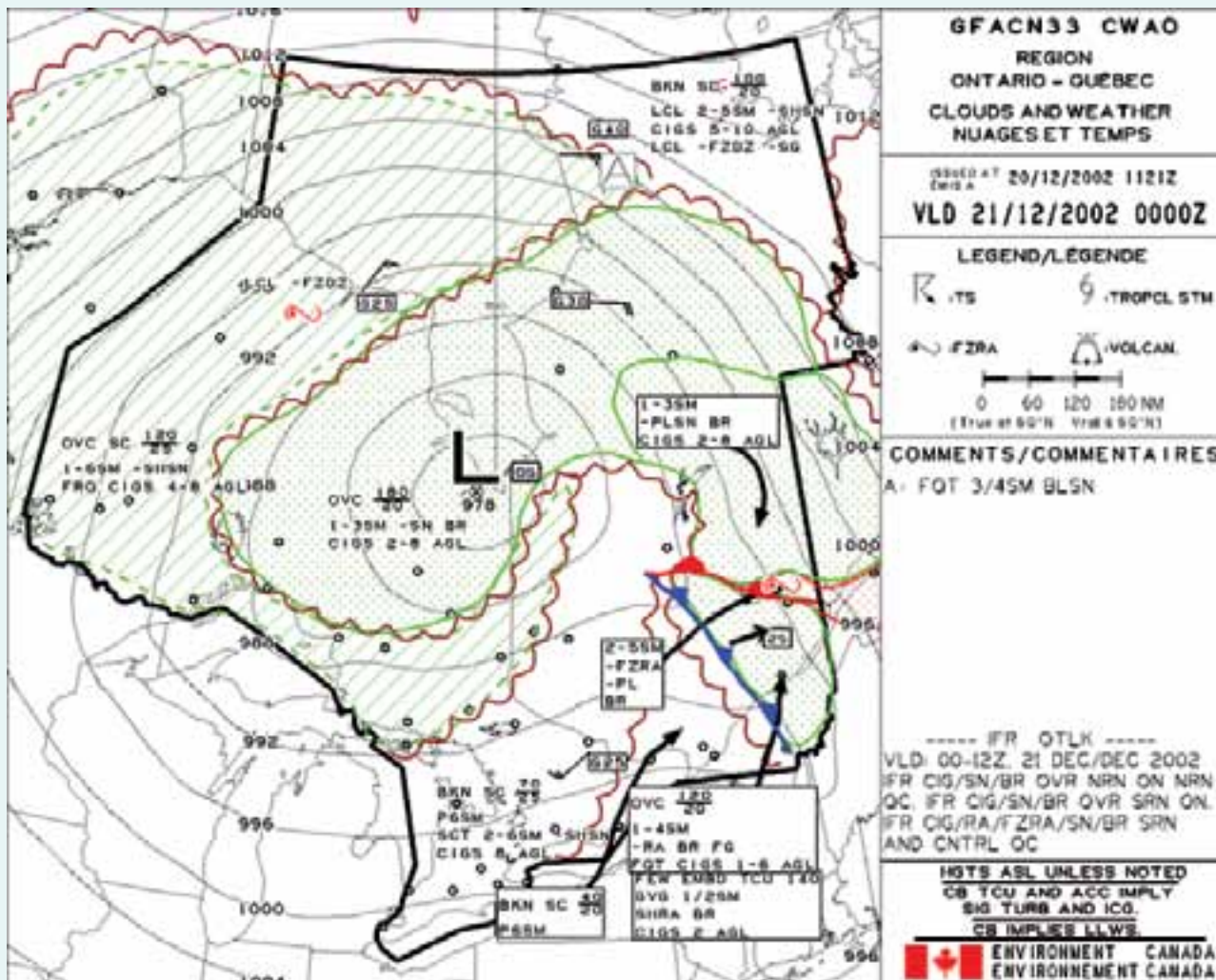

MET

The GFA clouds and weather chart provides a forecast of cloud layers and/or surface-based phenomena, visibility, weather and obstructions to vision at the valid time of that particular chart. Lines joining points of equal surface pressure (isobars) are depicted at 4-mb intervals. In addition, relevant synoptic features that are responsible for the portrayed weather are also depicted, with an indication of their speed and direction of movement at the valid time.

- (a) *Synoptic Features*: The motion of synoptic features when the speed of movement is forecast to be 5 KT or more will be indicated by an arrow and a speed value. For speeds less than 5 KT, the letters QS (quasi-stationary) are used. A low-pressure centre moving eastward at 15 KT with an associated cold front moving southeast at 10 KT would be indicated as follows:

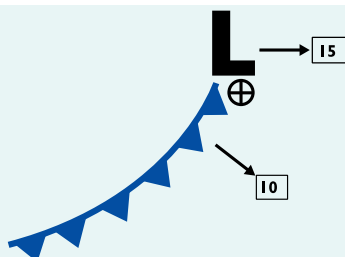

- (b) *Clouds*: The bases and tops of forecast clouds between the surface and 24 000 ft ASL will be indicated on the GFA clouds and weather chart. The tops of convective clouds (i.e. TCU, ACC, CB) are indicated, even if they extend above 24 000 ft ASL. Cirrus clouds are not depicted on the chart. The cloud type will be indicated if considered significant; however, convective clouds, such as CU, TCU, ACC and CB, will always be stated if forecast to be present.

A scalloped border encloses organized areas of clouds where the sky condition is either broken (BKN) or overcast (OVC). An organized area of broken cumulus clouds based at 2 000 ft ASL with tops at 8 000 ft ASL would be indicated as follows:

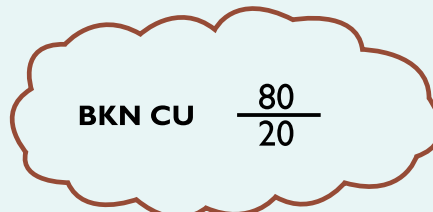

Where organized areas of clouds are not forecast and the visibility is expected to be greater than 6 SM, a scalloped border is not used. In these areas, the sky condition is stated using the terms SKC, FEW or SCT. In the following example, unorganized scattered clouds are forecast based at 3 000 ft ASL with tops at 5 000 ft ASL:

SCT $\frac{50}{30}$

When multiple cloud layers are forecast, the amount of cloud at each layer is based on the amount of cloud at that level, not on the summation amount. The bases and tops of each layer are indicated. For instance, a scattered layer of cumulus cloud based at 3 000 ft ASL with tops at 5 000 ft ASL and a higher overcast layer of altostratus cloud based at 10 000 ft ASL with tops at 13 000 ft ASL would be indicated as follows:

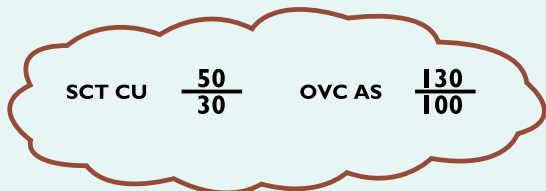

All heights are indicated in hundreds of feet ASL (2 means 200 ft, 45 means 4 500 ft, etc.) unless otherwise specified. Heights above ground level (AGL) are indicated by the abbreviation CIG (e.g. ST CIGS 5–10 AGL). A note to this effect is included in the comments box in the lower right-hand corner of the chart.

(c) *Surface-based Layers:* The abbreviation OBSCD (obscured) is used to describe surface-based layers. The vertical visibility into surface-based layers is measured in hundreds of feet AGL. Local obscured ceilings with a vertical visibility of between 300 and 500 ft AGL would be indicated as follows:

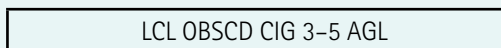

(d) *Visibility:* The forecast visibility is measured in statute miles (SM). When the visibility is expected to be greater than 6 SM, it is indicated as P6SM. A forecast visibility that is expected to vary between 2 and 4 SM with light rain showers would be indicated as:

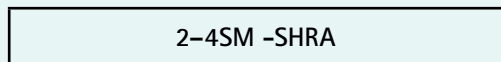

(e) *Weather and Obstructions to Vision:* Forecast weather is always included immediately after the visibility. Obstructions to vision are only mentioned when the visibility is forecast to be 6 SM or less (e.g. 2-4SM -RA BR). Only standard abbreviations are used to describe weather and obstructions to vision. Areas of showery or intermittent precipitation are shown as hatched areas enclosed by a dashed green line. Areas of continuous precipitation are shown as stippled areas enclosed by a solid green line. Areas of obstruction to vision not

associated with precipitation, where visibility is 6 SM or less, are enclosed by a dashed orange line. Areas of freezing precipitation are depicted in red and enclosed by a solid red line.

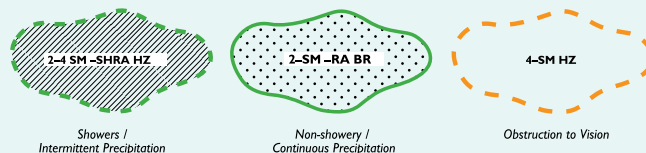

Weather and obstructions to vision in the GFA may include spatial qualifiers, which describe the coverage of the depicted meteorological phenomena.

Convective clouds and showers:

Abbreviation	Description	Spatial Coverage
ISOLD	Isolated	Less than 25%
SCT	Scattered	25-50%
NMRS	Numerous	Greater than 50%

Non-convective clouds and precipitation, low stratus ceilings, precipitation ceilings, icing, turbulence, and restrictions to visibility:

Abbreviation	Description	Spatial Coverage
LCL	Local	Less than 25%
PTCHY	Patchy	25-50%
XTNSV	Extensive	Greater than 50%

(f) *Isobars:* Isobars, which are lines joining points of equal mean sea level (MSL) pressure, are depicted on the GFA clouds and weather chart. Isobars are drawn at 4-mb intervals from a reference value of 1 000 mb.

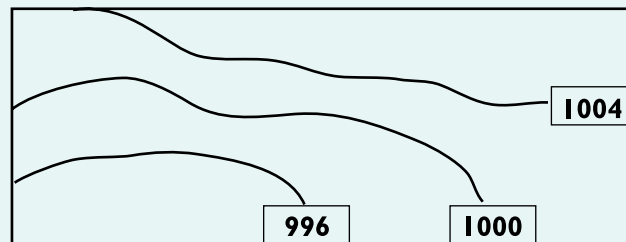

(g) *Surface Winds:* The speed and direction of forecast surface winds with a sustained speed of at least 20 kt are indicated by wind barbs and an associated wind-speed value. When accompanied by strong gusts, mean sustained winds of less than 20 kt may also be included, at the forecaster's discretion, if moderate mechanical turbulence is expected to occur as a result of the wind gusts. Wind gusts are indicated by the letter "G," followed by the peak gust speed in knots (kt). In the following example, the surface wind is forecast to be from the west (270° true) with a speed of 25 kt and a peak gust speed of 35 kt.



3.3.12 Icing, Turbulence and Freezing Level Chart

The graphic area forecast (GFA) icing, turbulence and freezing level chart depicts forecast areas of icing and turbulence as well as the expected freezing level at a specific time. Included on the chart are the type, intensity, bases and tops of each icing and turbulence area. Surface synoptic features such as fronts and pressure centres are also shown. This chart is to be used in conjunction with the associated GFA clouds and weather chart issued for the same period of validity.

and tops of each icing layer, measured in hundreds of feet above mean sea level (MSL), as well as the type of icing (e.g. “RIME”, “MXD” [mixed], “CLR” [clear]) will be indicated. Areas of light icing are described in the comments box. An area of moderate mixed icing based at 2 000 ft ASL with a top of 13 000 ft ASL would be indicated as follows:

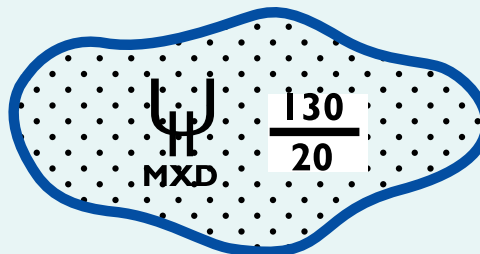

(a) *Icing*—Icing is depicted, in blue, whenever moderate or severe icing is forecast for the coverage area. The bases

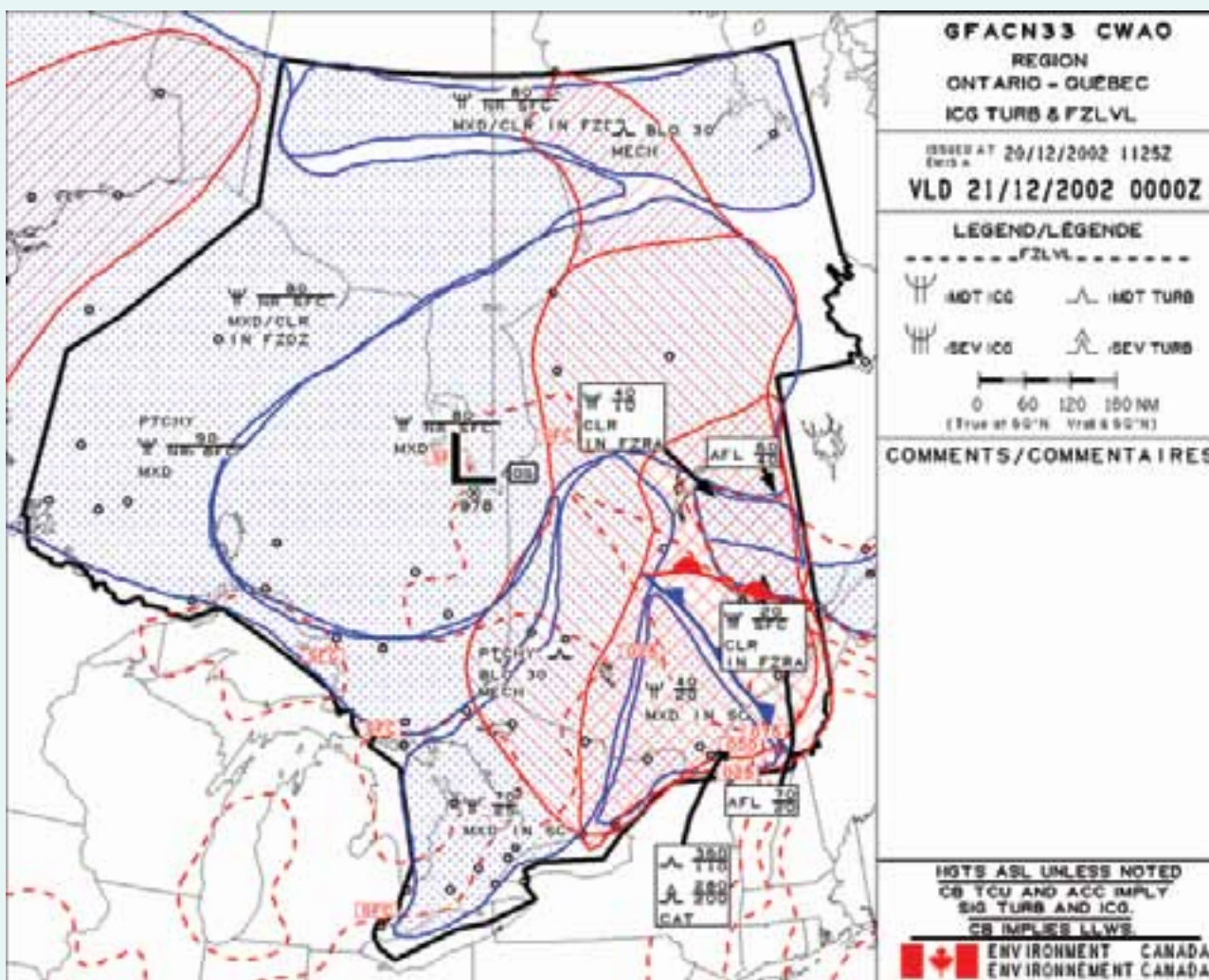

MEET

If icing is expected to be present during only part of the forecast period covered by the chart, the time of occurrence of the icing is indicated in the comments box.

Areas of severe icing are indicated with a denser stippling. The following is an example of an area of severe icing contained within an area of moderate icing:

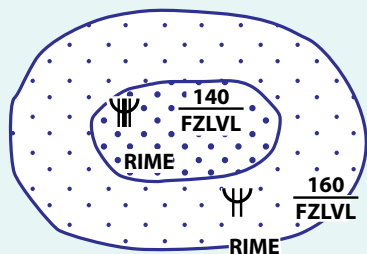

(b) *Turbulence*—Turbulence is depicted, in red, whenever moderate or severe turbulence is forecast for the coverage area. The base and top of each turbulence layer is measured in hundreds of feet ASL. If the turbulence is due to mechanical turbulence, low-level wind shear, lee/mountain waves, a significant low-level jet or is in clear air, an abbreviation indicating the cause of the turbulence will be included (e.g. MECH, LLWS, LEE, WV, LLJ or CAT). The following example indicates an area of moderate clear air turbulence (CAT) based at 8 000 ft ASL with a top at 20 000 ft ASL.

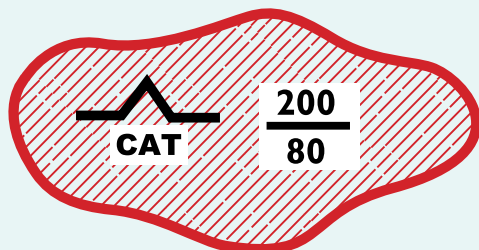

Severe turbulence is depicted with a higher density of hatching. The following example shows an area of severe turbulence surrounded by a larger area of moderate turbulence:

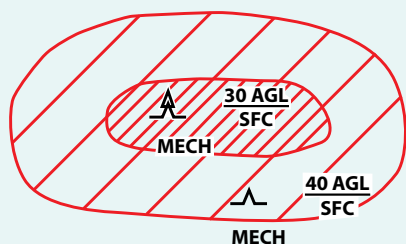

When separate areas of turbulence are occurring at different altitudes, the lower level is shown with hatching that slants upward to the right, while the higher level is depicted with hatching that slants downward to the right, as indicated below:

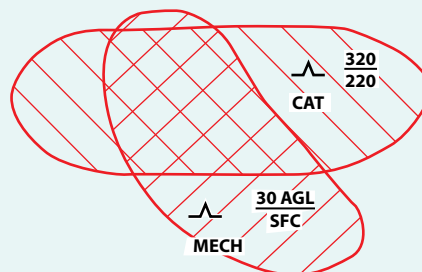

(c) *Freezing level*—When more than one freezing level is forecast, only the lowest level needs to be indicated, unless meteorological conditions are expected to be relevant to aviation safety (e.g. freezing precipitation aloft). An above freezing layer (AFL) is indicated by a closed area as shown below:

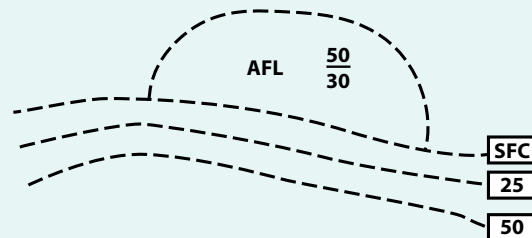

Temporal changes in the freezing level, when significant, are indicated in the comments box of the chart, as in the following example:

FZLVL 20 LWRG TO SFC AFT 03Z

(d) *Low level jet (LLJ)*—An LLJ is included on the GFA icing, turbulence and freezing level chart when it is expected to have a peak core speed of 50 kt or more. It may be included at speeds between 35 and 45 kt when significant associated turbulence or shear is expected. An LLJ is depicted as follows, with the wind being in the direction of the arrow and the speed shown being the maximum expected wind speed:

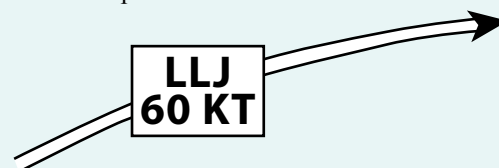

MET

In general, LLJs are not included if they are above 6 000 ft ASL, except as required over higher terrain. The height of the jet is not indicated. In many cases, there may be associated turbulence, as shown in the example below:

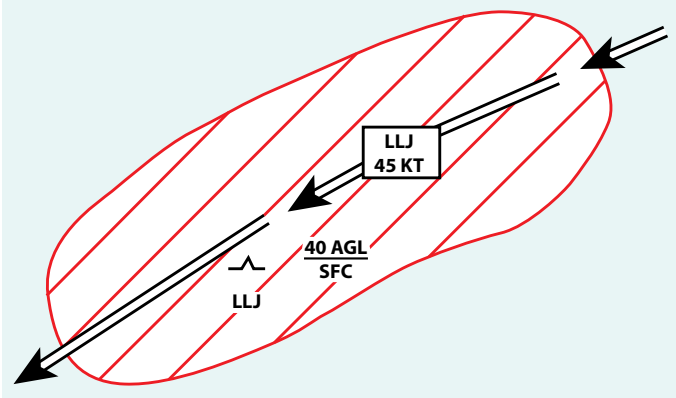

3.3.13 GFA Amendments

The GFA is automatically amended by AIRMET bulletins whenever weather conditions that are considered significant to aviation have not been forecast and subsequently occur, or when they have been forecast but do not occur. Each AIRMET will indicate which GFA is being amended. In addition, the GFA is automatically amended by SIGMET bulletins, even though it is not explicitly stated in the SIGMET itself.

3.3.14 GFA Corrections

The GFA will be re-issued in the event that one or more of the original GFA charts contains a significant error which, if left uncorrected, could result in an erroneous interpretation of the GFA. In this event, only the erroneous chart(s) is corrected and reissued with an appropriate explanation in the comments box.

When re-issued, the correction code “CCA” is added to the first line of the title box to indicate the first correction, “CCB” for the second, “CCC” for the third, etc.

GFACN33 CWUL CCA REGION ONTARIO-QUÉBEC CLOUDS AND WEATHER NUAGES ET TEMPS	
ISSUED AT ÉMIS A	17/09/1999 1211Z
VLD:	17/09/1999 1200Z

3.4 AIRMET

3.4.1 Definition

An AIRMET is a short-term weather advisory intended primarily for aircraft in flight, to notify pilots of potentially hazardous weather conditions not described in the current graphic area forecast (GFA) and not requiring a SIGMET. Its purposes are to ensure dissemination of significant meteorological changes to pilots after briefing or departure and to automatically amend the GFA.

3.4.2 Criteria

The criteria for issuing an AIRMET are the unforeseen development, dissipation or nonoccurrence of forecast:

- (a) IMC conditions (broken or overcast cloud condition at less than 1 000 ft. AGL and/ or visibility less than 3 SM);
- (b) freezing precipitation (not requiring a SIGMET);
- (c) moderate icing;
- (d) moderate turbulence;
- (e) thunderstorms (isolated as opposed to a line);
- (f) the surface mean wind over a large area increases to 20 KT. or more, or an increase in gusts to 30 KT. or more, when no winds were originally forecast; or
- (g) the difference between the forecast and observed wind direction is greater than 60°.

3.4.3 Validity

An AIRMET is valid upon receipt until it is updated or cancelled. It will also be superseded by the issue of the next regular GFA. When two or more phenomena requiring separate AIRMETS occur, separate AIRMETS with different alphanumeric identifiers (e.g., A1 for the first phenomenon, and B1 for the second) will be issued by the responsible weather centre. An alphanumeric identifier, such as A2 or B2, would indicate that a previously issued AIRMET (A1 or B1) had been amended. AIRMETS will be worded in abbreviated plain English using standard abbreviations. Units of measure will be stated.

EXAMPLES	DECODE OF EXAMPLES
WACN34 CYQX 200720 AIRMET A1 ISSUED AT 0720Z CYQX AMEND GFACN34 CWUL 200530 ISSUE	AIRMET Header for Newfoundland Weather Centre, time 0720 UTC on the 20th of the month. AIRMET A1 issued at 0720 UTC by the Newfoundland Weather Centre, which amends GFACN34 issued at 0530 UTC.
WTN AREA /4607N06441W/MONCTON– /4428N06831W/BANGOR– /4459N06455W/GREENWOOD– /4607N06441W/MONCTON	Within an area bounded by co-ordinates/Lat: 46°07'N Long: 64°41'W (Moncton) to/Lat: 44°28'N Long: 68°31'W (Bangor) to/Lat: 44°59'N Long: 64°55'W (Greenwood) to/Lat: 46°07'N Long: 64°41'W (Moncton)
DC9 RPRTD MDT RIME ICG IN FZDZ AT 07Z. FZDZ XPCD TO CONT UNCHGD TO 14Z.	A DC9 aircraft reported moderate rime icing in freezing drizzle at 0700 UTC. The freezing drizzle is expected to continue unchanged until 1400 UTC.

3.5 METEOROLOGICAL REFERENCE POINTS MAP



MET

The Meteorological Reference Points Map specifies locations that may be used in SIGMET or AIRMET, in addition to latitude and longitude co-ordinates, to describe the areal coverage of weather phenomena



3.6 ABBREVIATIONS – AVIATION FORECASTS

CONTRACTION	PLAIN LANGUAGE
ABV	above
ACCAS	altocumulus castellanus
ACRS	across
ACSL	standing lenticular altocumulus
ACT	active
AFL	above freezing layer
AFT	after
AHD	ahead
AIRMS	air mass
ALF	aloft
ALG	along
ALQDS	all quadrants
ALT	altitude
APCH	approach
APCHG	approaching
ASL	above sea level
AWOS	Automated Weather Observation System
BDRY	boundary
BECMG	becoming
BFR	before
BGN	begin
BGNG	beginning
BHND	behind
BKN	broken
BL	blowing
BLDG	building
BLO	below
BLZD	blizzard
BR	mist
BRF	brief
BRFLY	briefly
BRKS	breaks
BTN	between
CAT	clear air turbulence
CAVOK	ceiling and visibility OK
CB	cumulonimbus
CIG	ceiling
CLD	cloud
CLR	clear
CLRG	clearing

CONTRACTION	PLAIN LANGUAGE
CNTR	centre
CNTRD	centred
CONDS	conditions
COTRAILS	condensation trails
CONTUS	continuous
CONTG	continuing
CST	coast
CU	cumulus
DCRG	decreasing
DEG	degree
DEWPNT	dew point
DFUS	diffuse
DIST	distant
DNS	dense
DNSLP	downslope
DP	deep
DPNG	deepening
DRFTG	drifting
DURG	during
DVLPG	developing
DZ	drizzle
E	east
ELSW	elsewhere
ELY	easterly
EMBD	embed
ENDG	ending
ENTR	entire
FCST	forecast
FEW	few clouds
FG	fog
FILG	filling
FLWD	followed
FLWG	following
FM	from
FNT	front
FRQ	frequent
FROIN	frost on indicator
FROPA	frontal passage
FRQ	frequent
FT	feet, foot
FU	smoke

CONTRACTION	PLAIN LANGUAGE
FZ	freezing
FZLVL	freezing level
GND	ground
GRAD	gradient
GRDLY	gradually
HGT	height
HI	high
HLTP	hilltop
HND	hundred
HR	hour
HVY	heavy
ICG	icing
ICGIC	icing in cloud
ICGIP	icing in precipitation
IMDTLY	immediately
INCRG	increasing
INDEF	indefinite
INSTBY	instability
INTMT	intermittent
INTS	intense
INTSFY	intensify
ISLD	island
ISOL	isolate(d)
KT	knot(s)
LCL	local
LFTG	lifting
LGT	light
LIFR	low IFR
LK	lake
LLJ	low level jet stream
LLWS	low level wind shear
LN	line
LO	low
LTL	little
LTNG	lightning
LVL	level
LWIS	limited weather information system
LWR	lower
LWRG	lowering
LYR	layer
MDFYD	modified

CONTRACTION	PLAIN LANGUAGE
MDT	moderate
MI	shallow
MID	middle
MOVG	moving
MPH	miles per hour
MRNG	morning
MRTM	maritime
MSTR	moisture
MTS	mountains
MVFR	marginal VFR
MXD	mixed
MXG	mixing
N	north
NE	northeast
NELY	northeasterly
NGT	night
NLY	northerly
NM	nautical mile(s)
NMRS	numerous
NR	near
NRLY	nearly
NSW	no significant weather
NW	northwest
NWLY	northwesterly
OBSC	obscure(d)
OCLD	occlude
OCLDG	occluding
OCLN	occlusion
OCNL	occasional
OCNLY	occasionally
OFSHR	offshore
ONSHR	onshore
ORGPC	orographic
OTLK	outlook
OTWZ	otherwise
OVC	overcast
OVR	over
OVRNG	overrunning
PCPN	precipitation
PD	period
PL	ice pellets

CONTRACTION	PLAIN LANGUAGE
PRECDD	preceded
PRECDS	precedes
PRES	pressure
PRESFR	pressure falling rapidly
PRESRR	pressure rising rapidly
PROG	prognostic, prognosis
PRSTG	persisting
PSG	passage, passing
PSN	position
PTCHY	patchy
PTLY	partly
RA	rain
RDG	ridge
REP	report
REPS	reports
RFRMG	reforming
RGN	region
RMNG	remaining
RPDLY	rapidly
RPRT	report
RSG	rising
RUF	rough
RVR	river
S	south
SCT	scattered
SCTR	sector
SE	southeast
SECT	sector
SECTS	sectors
SELY	southeasterly
SEV	severe
SFC	surface
SH	shower
SHFT	shift
SHFTG	shifting
SHLW	shallow
SKC	sky clear
SLO	slow
SLOLY	slowly
SLY	southerly
SM	statute mile(s)

CONTRACTION	PLAIN LANGUAGE
SML	small
SN	snow
SNRS	sunrise
SNST	sunset
SPECI	special
SPRDG	spreading
SQ	squall
STBL	stable
STG	strong
STGTN	strengthen
STNRY	stationary
SVRL	several
SW	southwest
SWLY	southwesterly
SXN	section
SYS	system
TCU	towering cumulus
TEMP	temperature
TEMPO	temporary
THK	thick
THKNG	thickening
THN	thin
THNC	thence
THNG	thinning
THRU	through
THRUT	throughout
THSD	thousand
TILL	until
TRML	terminal
TROF	trough
TROWAL	trough of warm air aloft
TRRN	terrain
TS	thunderstorm
TURB	turbulence
TWD	toward
UNSTBL	unstable
UPR	upper
UPSLOP	upslope
UTC	coordinated universal time
VC	vicinity
VGSS	voice generator sub-system

CONTRACTION	PLAIN LANGUAGE
VIS	visibility
VLY	valley
VRB	variable
VV	vertical visibility
W	west
WDLY	widely
WK	weak
WLY	westerly
WND	wind
WRM	warm

CONTRACTION	PLAIN LANGUAGE
WS	wind shear
WV	wave
WX	weather
XCP	except
XT	extend
XTDG	extending
XTRM	extreme
XTSV	extensive
Z	ZULU (or UTC)

3.7 TURBULENCE REPORTING CRITERIA TABLE

INTENSITY	AIRCRAFT REACTION	REACTION INSIDE AIRCRAFT
LIGHT	<p>Turbulence that momentarily causes slight, erratic changes in altitude and/or attitude (pitch, roll, yaw). Report as "Light Turbulence".</p> <p style="text-align: center;">OR</p> <p>Turbulence that causes slight, rapid and somewhat rhythmic bumpiness without appreciable changes in altitude or attitude. Report as "Light Chop".</p>	Occupants may feel a slight strain against seat belts or shoulder straps. Unsecured objects may be displaced slightly. Food service may be conducted and little or no difficulty is encountered in walking.
MODERATE	<p>Turbulence that is similar to Light Turbulence but of greater intensity. Changes in altitude and/or attitude occur but the aircraft remains in positive control at all times. It usually causes variations in indicated airspeed. Report as "Moderate Turbulence".</p> <p style="text-align: center;">OR</p> <p>Turbulence that is similar to Light Chop but of greater intensity. It causes rapid bumps or jolts without appreciable changes in aircraft altitude or attitude. Report as "Moderate Chop".</p>	Occupants feel definite strains against seat belts or shoulder straps. Unsecured objects are dislodged. Food service and walking are difficult.
SEVERE	<p>Turbulence that causes large, abrupt changes in altitude and/or attitude. It usually causes large variations in indicated airspeed. Aircraft may be momentarily out of control. Report as "Severe Turbulence".</p>	Occupants are forced violently against seat belts or shoulder straps. Unsecured objects are tossed about. Food service and walking impossible.

NOTES 1: Occasional: Less than 1/3 of the time.
 Intermittent: 1/3 to 2/3.
 Continuous: More than 2/3.

2: Pilots should report location(s), time (UTC), intensity, whether in or near clouds, altitude, type of aircraft and, when applicable, duration of turbulence. Duration may be based on time between two locations or over a single location. All locations should be readily identifiable.

Examples

- Over REGINA 1232Z, moderate turbulence, in cloud FL310, B737.
- From 50 NM EAST of WINNIPEG to 30 NM WEST of Brandon 1210 to 1250Z occasional moderate chop, FL330, AIRBUS.
- High level turbulence (normally above 15 000 feet ASL) not associated with cumuloform clouds, including thunderstorms, should be reported as CAT (clear air turbulence) preceded by the appropriate intensity, or light or moderate chop.

MET

3.8 AERODROME FORECAST LOCATIONS

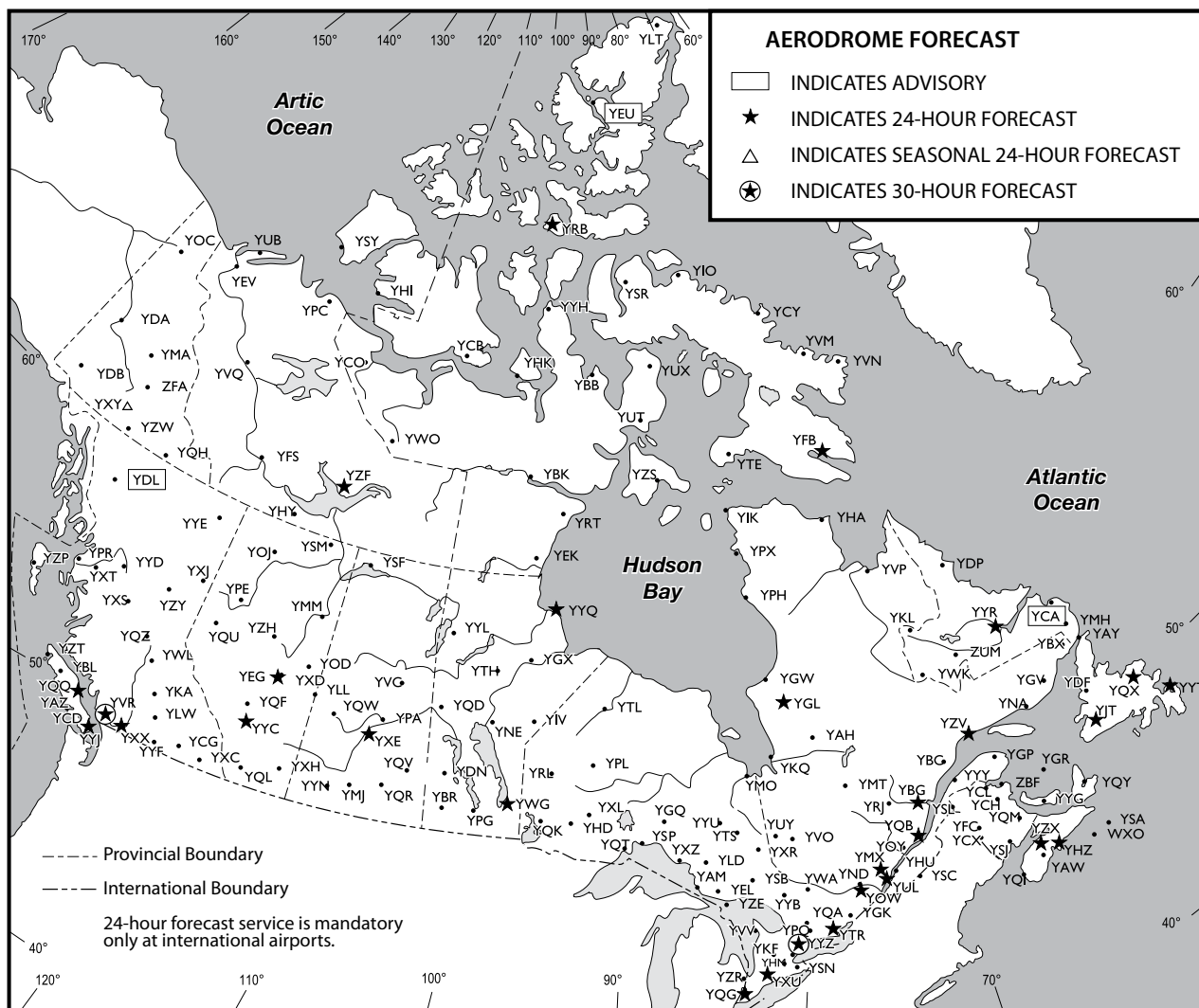

MET

3.9 AERODROME FORECAST – TAF

3.9.1 General

TAF is the international meteorological code for an aerodrome forecast, which is a description of the most probable weather conditions expected to occur at an aerodrome, together with their most probable time of occurrence. It is designed to meet the pre-flight and in-flight requirements of flight operations. The abbreviations of expected weather conditions will follow the same form and order of the METAR (see MET 3.15), and will have the same meaning.

TAFs are intended to relate to weather conditions for flight operations within 5 NM of the centre of the runway complex, depending on local terrain. A regular and complete observation program that meets Environment Canada standards is a prerequisite for the production of a TAF. Aerodrome advisories are issued when this observation program prerequisite cannot be completely satisfied.

Aerodrome advisories are identified by the word “ADVISORY” appearing after the date/time group, followed by one of the qualifying reasons listed below. Advisories are formatted in the same manner as the TAF.

OFFSITE: The advisory is based on an observation that is not taken at or near the airport. In normal situations, an observation is considered representative of the specific weather conditions at the aerodrome if it is taken within 1.6 NM (3 km) of the geometric centre of the runway complex. “OFFSITE” is added after the word “ADVISORY,” followed by one space, if an observation is not considered representative. It is intended to indicate to the users that the observations do not necessarily reflect the actual conditions at the aerodrome.

In cases where the 1.6 NM (3 km) criterion does not apply because of local characteristics, the representativeness of the observations shall be determined and approved by the Regional Director of Environmental Services at Environment Canada.

OBS INCOMPLETE or NO SPECI: The advisory is based on incomplete data, either because the observations could not be completed, or the aerodrome does not have an on-going weather watch in order to produce SPECIs. “OBS INCOMPLETE” or “NO SPECI” shall be added after the word “ADVISORY,” followed by one space.

3.9.2 National Variations

As with the METAR code, even though TAF is an international code, there are national variations. For example, “CAVOK” is not authorized for use in Canadian TAFs, while “RMK” is used, but is not part of the international code. A detailed account of the differences that Canada has filed with the World Meteorological Organization (WMO) may be found in the WMO *Manual on Codes*, Volume II, Regional Codes and National Coding Practices (No. 306). (See MET 1.1.7 for ordering information and MET 1.1.8 for differences from ICAO Annex 3.)

3.9.3 Sample Message

TAF CYXE 281139Z 2812/2912 24010G25KT WS011/
27050KT 3SM -SN BKN010 OVC040 TEMPO 2818/2901 1
1/2SM -SN BLSN BKN008 PROB30 2820/2822 1/2SM SN
VV005 FM290130Z 28010KT 5SM -SN BKN020 BECMG
2906/2908 00000KT P6SM SKC RMK NXT FCST BY
281800Z

(a) *Sample Message Decoded:* Aerodrome Forecast; Saskatoon, Saskatchewan; issued on the 28th day of the month at 1139Z; covers the period from the 28th day of the month at 1200Z to the 29th day of the month at 1200Z; surface wind 240° true at 10 kt, gusting to 25 kt; wind shear is forecast to exist in the layer from the surface to 1 100 ft AGL, with the wind at the shear height of 270° true at 50 kt; forecast prevailing visibility is 3 SM in light snow; forecast cloud layers are broken at 1 000 ft and overcast at 4 000 ft; between 1800Z on the 28th day and 0100Z on the 29th day there will be a temporary change to the prevailing visibility to 1 1/2 SM in light snow and moderate blowing snow with a broken cloud layer at 800 ft; there is a 30% probability between 2000Z and 2200Z on the 28th day that the prevailing visibility will be 1/2 SM in moderate snow and create an obscuring phenomena, resulting in a vertical visibility of 500 ft; at 0130Z on the 29th day there will be a permanent change, the wind is forecast to be 280° true at 10 kt with a prevailing visibility of 5 SM in light snow and a broken cloud layer at 2 000 ft; between 0600Z and 0800Z on the 29th day there will be a gradual change in the weather to calm winds and a forecast visibility greater than 6 SM, and the sky will be clear of clouds; Remarks: the next routine aerodrome forecast for this site will be issued by 1800Z on the 28th day.

- (b) *Report Type:* The code name “TAF” is given in the first line of text. It may be followed by “AMD” for amended or corrected forecasts.
- (c) *Location Indicator:* A four-letter ICAO location indicator is used, as in the METAR.
- (d) *Date/Time of Origin:* As with the METAR format, the date (day of the month) and time (UTC) of origin are included in all forecasts. TAFs are issued approximately 30 min before the validity period. Some forecasts have update cycles as frequent as every three hours; however, the next issue time will always be indicated in the “Remarks” section.
- (e) *Period of Validity:* The period of validity for the TAF is indicated by two four-digit date/time groups; the first four-digit group indicates the start date and time of the TAF, and the second four-digit group indicates the end date and time of the TAF. A TAF is considered to be valid from the moment it is issued (e.g. a TAF with an indicated period of validity from 1100Z to 2300Z that was issued at 1040Z is considered to be valid from 1040Z) until it is amended; until the next scheduled TAF for the same aerodrome is issued; or until the period of validity ends and no new TAF has been issued. The maximum period of validity for a TAF is 30 hr; however, some TAFs have staggered issue times and more frequent update cycles, which affects their periods of validity.
- (f) *Wind:* This group forecasts the 2-min mean wind direction and speed to the nearest 10° true, and speed to the nearest whole knot. “KT” is used to indicate the speed units. If the maximum gust speed is forecast to exceed the mean speed by 10 kt or more, the letter G and the value of the gust speed, in knots, is added between the mean wind and the unit indicator (KT). “VRB” is normally coded for variable direction only if the wind speed is 3 kt or less; however, it may also be coded with higher speeds when it is impossible to forecast a single direction (e.g. when a thunderstorm passes). A north wind of 20 kt would be coded as 36020KT, while calm wind is coded as “00000KT.”
- (g) *Low-Level Wind Shear:* This group is used if the forecaster has strong evidence to expect significant, non-convective wind shear that could adversely affect aircraft operation within 1 500 ft AGL over the aerodrome. The height of the top of the shear layer (in hundreds of feet AGL) is given, followed by the forecast wind speed and direction at that height.

While the main effect of turbulence is related to erratic changes in altitude or attitude of the aircraft, or both, the main effect of wind shear is the rapid gain or, more critical, loss of airspeed. Therefore, for forecasting purposes, any cases of strong, non-convective low-level wind shear within 1 500 ft AGL will be labelled as “WS.”

MET

To a large extent, wind shear is an element that, for the time being, cannot be satisfactorily observed from the ground. As a result, aircraft observations and radiosonde reports represent the only available evidence.

However, the following guidelines are used to establish whether significant non-convective wind shear hazardous to aircraft exists:

- (i) vector magnitude exceeding 25 kt within 500 ft AGL;
 - (ii) vector magnitude exceeding 40 kt within 1 000 ft AGL;
 - (iii) vector magnitude exceeding 50 kt within 1 500 ft AGL;
 - (iv) a pilot report of loss or gain of IAS of 20 kt or more within 1 500 ft AGL.
- (h) *Prevailing Visibility*: The horizontal prevailing visibility is indicated in statute miles and fractions up to 3 SM, then in whole miles up to 6 SM. Visibilities greater than 6 SM are indicated as *P6SM*. The letters “SM” are added, without a space, to each forecast visibility, to identify the unit.
- (i) *Significant Weather*: Forecast significant weather may be decoded using the list of significant weather given in the “WMO Code, Table 4678” (MET 3.15.3). Intensity and proximity qualifiers, descriptors, precipitation, obscuration and other phenomena are included as required. A maximum of three significant weather groups is allowed per forecast period. If more than one group is used, they are considered one entity. When one of the significant weather groups is forecast to change, all the significant weather groups that will apply after the change are indicated following the change group. Details on the specific effects of change groups on significant weather will be addressed under the change group headings.

NOTE: The meaning of the proximity qualifier, vicinity (VC), in the TAF code differs slightly from that in the METAR. In the METAR code, “VC” means elements observed within 5 mi., but not at the station. In the TAF code, “VC” means between 5 and 10 NM from the centre of the runway complex.

- (j) *Sky Condition*: Sky condition is decoded as in a METAR. Possible codes for sky cover amounts are SKC, FEW, SCT, BKN, OVC and VV.

In case of a significant change in a cloud layer, as forecast using “BECMG” or “TEMPO”, the entire cloud group, including those cloud layers not expected to change, shall be repeated.

CB layers are the only forecast layers to have cloud type identified, e.g. “BKN040CB.”

- (k) *Change Groups*: In all change groups, multiple elements within a significant weather or sky condition group, or both, are considered as single entities for the purposes of revising their elements, i.e. a forecast of “SCT030 BKN050 OVC080...change indicator...BKN050” would indicate that there is only a single cloud layer forecast after the change indicator, and the other three cloud layers forecast prior to the change indicator will no longer exist.

FM—Permanent Change Group (Rapid): FM is the abbreviation for “from.” It is used for a permanent change to the forecast that will occur rapidly. All forecast conditions given before this group are superseded by the conditions indicated after the group. In other words, a complete forecast will follow and all elements must be indicated, including those for which no change is forecast. The time group represents hours and minutes in UTC.

Example: “FM280945” would decode as the beginning of a new part period forecast from the 28th day of the month at 0945Z.

NOTE: Where the permanent change group indicator (FM) indicates a change after the beginning of a whole hour, as in the example above, any subsequent use of a gradual change group (BECMG) or transitory change group (TEMPO) shall indicate changes after the time indicated in hours and minutes in the “from” (FM) indicator. Using the above example, if there was a subsequent use of “TEMPO 2809/2811,” the temporary change would be between 0945Z and 1100Z on the 28th day of the month.

BECMG—Permanent Change Group (Gradual): If a permanent change in a few weather elements is forecast to occur gradually, with conditions evolving over a period of time (normally one to two hours, but not more than four hours), the new conditions that differ from those immediately prior are indicated following “BECMG.” Normally only those elements for which a change is forecast to occur will follow “BECMG.” Any forecast weather element not indicated as part of the “BECMG” group remains the same as in the period prior to the onset of the change.

If a significant change in weather or visibility is forecast, all weather groups, as well as the visibility, are indicated following “BECMG,” including those that are unchanged. When the ending of significant weather is forecast, the abbreviation “NSW” (no significant weather) is used.

The start and stop time of the change period is indicated by two four-digit date/time groups following “BECMG.” The first two digits of each group indicate the date, while the last two digits of each group indicate the time in whole UTC hours.

As a general rule, to keep the forecast clear and unambiguous, the use of the “BECMG” change group is kept to a minimum, and confined to those cases where only one, or at most two, weather groups are expected to change while all the others

stay the same. In those cases where more than two groups are expected to change, the permanent change group “FM” will be used to start a new self-contained part period.

For the purposes of flight planning, and specifically the selection of IFR alternate aerodromes, if forecast conditions are improving, the new conditions will apply when the change period is complete, and if the conditions are deteriorating, the new conditions will apply at the beginning of the period.

Example: “BECMG 2808/2809 OVC030” would decode as a change towards overcast sky conditions at 3 000 ft AGL occurring gradually between 0800Z and 0900Z on the 28th day of the month; and

- (a) if the previous sky condition forecast was for better than overcast conditions at 3 000 ft AGL, then the change would apply as of 0800Z; or
- (b) if the previous sky condition forecast was for worse than overcast conditions at 3 000 ft AGL, then the change would apply as of 0900Z.

TEMPO—Transitory Change Group: If a temporary fluctuation in some or all of the weather elements is forecast to occur during a specified period, the new conditions that differ from those immediately prior are indicated following “TEMPO.” In other words, when an element is not indicated after “TEMPO,” it shall be considered to be the same as that for the prior period. The time period, as with “BECMG,” is indicated by two four-digits date/time groups following “TEMPO.” The first two digits of each group indicate the date, while the last two digits of each group indicate the time in whole UTC hours.

Example: ...FM281100 VRB03KT 3SM RA BR OVC020 TEMPO 2812/2815 1SM RA BR FM281500...

In this example, the cloud group “OVC020” is not repeated after “TEMPO” because it is forecast to remain unchanged. On the other hand, the weather group “RA BR” is repeated after “TEMPO” because a significant change in visibility is forecast.

When a significant change in weather or visibility is forecast, all weather groups are indicated following “TEMPO,” including those that are unchanged, and any weather element not indicated is forecast to remain the same as in the period prior to the temporary fluctuation. When the ending of significant weather is forecast, the abbreviation “NSW” (no significant weather) is used.

“TEMPO” is only used when the modified forecast condition is expected to last less than one hour in each instance, and if expected to recur, the total period of the modified condition will not cover more than half of the total forecast period. The total period of the modified condition is the time period during which the actual modified weather condition is expected to occur, and not the total time stated for the “TEMPO” time period. When the modified forecast condition is expected to last more

than one hour, either “FM” or “BECMG” must be used.

PROB—Probability Group: In order to indicate the probability of occurrence of alternative values of forecast groups, *PROB30* (a 30% probability) or *PROB40* (a 40% probability) is placed directly before the change group’s validity period and alternative value(s) to indicate that different conditions will occur within the specified time period. The time period is given in whole UTC hour values. For example, “PROB30 2817/2821” would indicate that between 1700Z and 2100Z on the 28th day of the month there is a 30% probability that the indicated weather will occur. The weather elements used in the PROB group are restricted to hazards to aviation, which include, but are not limited to, the following:

- thunderstorms;
- freezing precipitation;
- low-level wind shear below 1 500 ft AGL; or
- ceiling and visibility values important to aircraft operations (e.g. threshold such as alternate limits, lowest approach limits).

A probability of less than 30% of actual values deviating from those forecasts is not considered to justify the use of the PROB group. When the possibility of an alternative value is 50% or more, this shall be indicated by the use of BECMG, TEMPO or FM, as appropriate. The PROB group will not be used in combination with the TEMPO or BECMG groups.

- (l) **Remarks:** Remarks will appear in TAF from Canada, prefaced by “RMK.” Currently, the following remarks are allowed:

- (i) **“FCST BASED ON AUTO OBS”**
This remark indicates that the TAF is based on observations taken by an AWOS.
- (ii) **“NXT FCST BY 290000Z”**
This remark indicates the date and time (UTC) the next regular TAF will be issued, which will correspond to the beginning of its new period of validity. This remark will normally mark the end of the TAF.
- (iii) **PARTIAL PROGRAM NOTICES**
For aerodromes with a partial observing program (e.g. no night-time observations are taken), a remark is included in the last regular TAF issued for the day, to indicate when forecast coverage will resume, e.g. “NXT FCST BY 291045Z,” “NO FCST COVERAGE 2820–2911Z,” or “NO FCST ISSUED UNTIL FURTHER NOTICE.”
- (iv) **POSSIBLE DISCREPANCIES**
Forecasters will use remarks to explain possible discrepancies between an AWOS and a TAF if the forecasters have reason to believe that the AWOS observations are not representative of the actual weather at the aerodrome. For example, the remarks could be “RMK AUTO OBS REPG NON-REPRESENTATIVE WND SPD” or “RMK AUTO OBS REPG NON-REPRESENTATIVE VIS.”

3.9.4 Aerodrome Forecasts from AWOS Sites

At some sites equipped with AWOS, forecasters will issue an aerodrome forecast (TAF) based in part on the AUTO observations made by the AWOS at the aerodrome. The only visible distinction between this forecast and a TAF that is based on human observations is the comment at the end of the TAF “FCST BASED ON AUTO OBS”. The TAF based on automated observations, like the TAF based on human observations, provides a description of the most probable weather conditions expected to occur at an aerodrome, together with the most probable time of occurrence.

The abbreviated comment “FCST BASED ON AUTO OBS” at the end of the TAF is meant to inform pilots that the forecast has been developed from an automated weather observation. The pilot using this forecast should be familiar with the characteristics of AWOS weather observations, and the comparison of automated and human observations contained in MET 3.15.5, e.g. the AWOS cloud height

sensor tends to under-read during precipitation events. The forecaster is also familiar with AWOS characteristics and has taken time to analyze not only AWOS data, but also additional information such as satellite and radar imagery, lightning data, remote video imagery, pilot reports, and observations from surrounding stations. Based on integration of this data, the forecaster may have inferred actual weather conditions that differ slightly from the AWOS report. On those few occasions when there are differences between an AWOS report and a TAF, it may not imply that the TAF is inaccurate, or that an amendment is required. In the event that an AWOS sensor is missing, inoperative, or functioning below standards, the forecaster will attempt to infer the value of the missing weather element from other available data. If the forecaster is unable to infer the weather conditions, a decision may be made to cancel the TAF, pending correction of the problem. The decision to cancel will depend on the weather conditions prevailing at the time, and how critical the missing information is to the issuance of a credible TAF based on the automated data that is available.

3.10 CANADIAN FORECAST WINDS AND TEMPERATURES ALOFT NETWORK

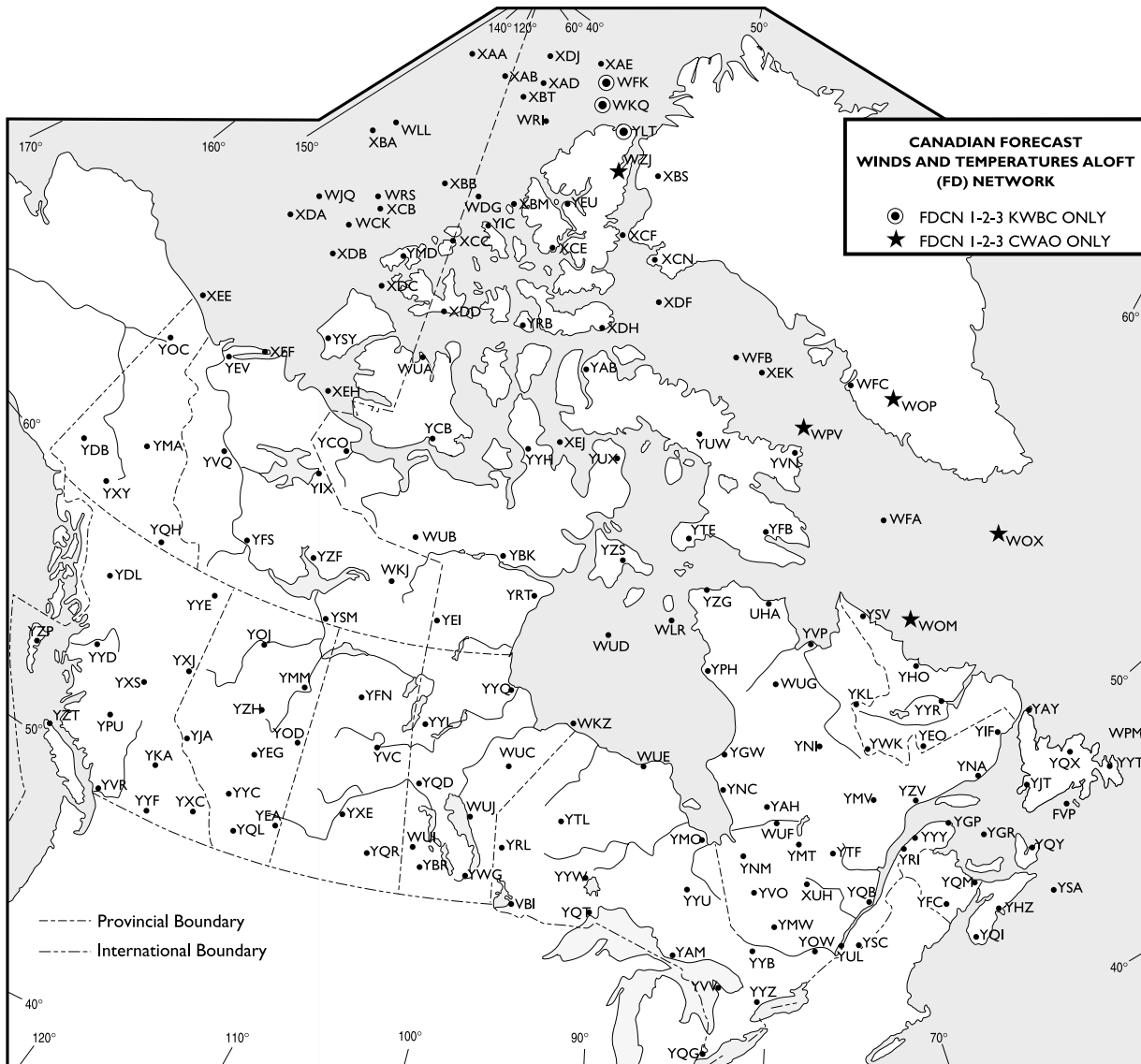

MEET

3.11 UPPER LEVEL WIND AND TEMPERATURE FORECASTS (FD)

Upper level wind and temperature forecasts (FD) are upper level forecasts of wind velocity, expressed in knots (kt) and to the nearest 10° true, and temperature, expressed in degrees Celsius (°C). Temperatures are not forecast for 3 000 ft; in addition, this level is omitted if the terrain elevation is greater than 1 500 ft. All forecast temperatures for altitudes over 24 000 ft are negative.

Data for the production of FDs are derived from a variety of atmospheric data sources, including upper air sounding measurements of pressure, temperature, relative humidity and wind velocity, taken at 32 sites twice daily (at 0000Z and 1200Z). Following the computer run of a subsequent numeric weather model, FDs are available at the times issued or during the periods of coverage indicated in MET 3.2.1.

Upper Wind and Temperature Forecasts

FDCN01 CWAO 071530
FCST BASED ON 071200 DATA VALID 080000 FOR USE 21-06

FT	3 000	6 000	9 000	12 000	18 000
YVR	9900	2415-07	2430-10	2434-10	2542-26
YYF	2523	2432-04	2338-08	2342-13	2448-24
YXC		2431-02	2330-06	2344-11	2352-22
YYC		2426-03	2435-06	2430-12	2342-22
YQL		2527-01	2437-05	2442-10	2450-21

FDCN1 KWBC 080440DATA
BASED ON 080000Z VALID 091200Z FOR USE 0900-1800Z.
TEMPS NEG ABV 24 000

FT	24 000	30 000	34 000	39 000
YVR	2973-24	293040	283450	273763
YYF	3031-24	314041	304551	204763
YXC	3040-27	315143	316754	306761
YYC	3058-29	317246	317855	306358
YQL	2955-28	306845	307455	791159

When the forecast speed is less than 5 kt, the code group is "9900," which reads "light and variable."

Encoded wind speeds from 100 to 199 kt have 50 added to the direction code and 100 subtracted from the speed. Wind speeds that have had 50 added to the direction can be recognized when figures from 51 to 86 appear in the code. Since no such directions exist (i.e. 510° to 860°), obviously they represent directions from 010° to 360°.

Should the forecast wind speed be 200 kt or greater, the wind group is coded as 199 kt, that is, 7799 is decoded as 270° at 199 kt or greater.

Examples of decoding FD winds and temperatures are as follows (the third and fourth examples are both for altitudes above 24 000 ft):

EXAMPLE	DECODED
9900 + 00	Wind light and variable, temperature 0°C
2523	250° true at 23 kt
791159	290° true (79 - 50 = 29) at 111 kt (11 + 100 = 111), temperature - 59°C
859950	350° true (85 - 50 = 35) at 199 kt or greater, temperature -50°C

3.12 UPPER LEVEL CHARTS

Upper level charts depict two forms of data: actual and forecast. Actual measured conditions are represented on analysed charts (ANAL) (see MET 3.20). These charts show conditions as they were at a specific time in the past. The other type, prognostic charts (PROG), show forecast conditions for a specific time in the future. Always check the map label for the type, date and valid time of the chart.

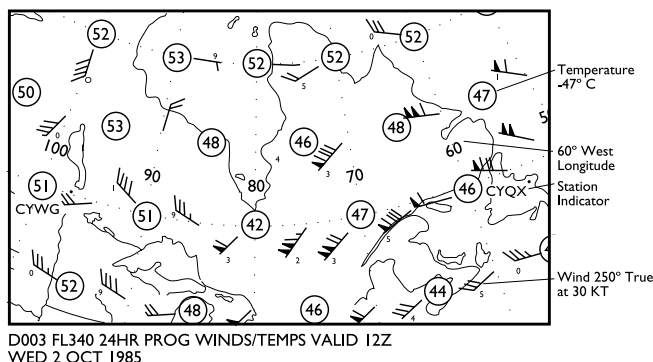

Prognostic Charts—PROG

Upper Level Winds and Temperature Charts

Upper level wind and temperature charts are issued by the world area forecast centre (WAFC), through the U.S. National Oceanic and Atmospheric Administration's (NOAA) National Weather Service (NWS) in Washington, D.C. Winds are depicted for FL240, FL340 and FL450 using arrow shafts with pennants (50 kt each), full feathers (10 kt each) and half feathers (5 kt each). The orientation of the shaft indicates wind direction (degree true) and a Small number at pennant end gives the 10's digit of the wind direction.

Temperatures (°C) are presented in circles at fixed grid points for the flight level. All temperatures are negative unless otherwise noted.

Wind and temperature information from these charts, in conjunction with the upper level wind and temperature forecast (FD) and significant weather charts (SIGWX), can be used to determine wind shear and other salient information such as the probability of clear air turbulence (CAT) over given points. Remember, the wind speed is normally highest at the tropopause and decreases above and below at a relatively constant rate.

MET

3.13 SIGNIFICANT WEATHER PROGNOSTIC HIGH-LEVEL CHARTS (SIGWX HI LVL)

These charts, produced for the mid- and high-levels, show occurring or forecast weather conditions considered to be of concern to aircraft operations. The world area forecast centre (WAFC), through the U.S. National Oceanic and Atmospheric Administration's (NOAA) National Weather Service (NWS) issues a chart depicting forecast weather conditions between FL250 and FL630. The meteorological conditions depicted and the symbols used are:

- (a) *active thunderstorms*—the cumulonimbus (CB) symbol is used when thunderstorms occur, or are forecast to occur, over a widespread area, along a line, embedded in other cloud layers, or when concealed by a hazard. The amounts and the spatial coverage (in brackets) are indicated as:

ISOLD (isolated) – for individual CBs (less than 25%)
OCNL (occasional) – for well-separated CBs (25 - 50% inclusive)
NMRS (numerous) – for CBs with little or no separation (greater than 50%)

Embedded CBs may or may not be protruding from the cloud or haze layer. The following abbreviations are used to indicate the presence of CBs: ISOL embedded CB, OCNL embedded CB, FRQ embedded CB and FRQ CB. All other clouds are depicted using OKTA amounts, followed by the cloud type. In certain cases the abbreviation LYR (layer or layered) is used to indicate cloud structure.

- (b) *cloud heights*—when cloud tops or bases exceed the upper or lower limits of a significant weather prognostic chart, an XXX symbol is used on the appropriate side of the dividing line. Consider, for example, the significant weather prognostic chart that extends from FL250 to FL630. If well-separated embedded CBs based below FL250 and topped at FL450 were present, this would be depicted as follows:

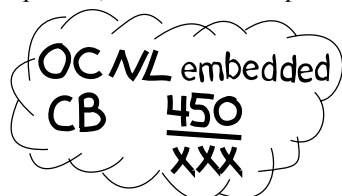

The scalloped line indicates the area in which the conditions written inside apply.



- (c) *tropopause height*—tropopause heights are depicted as flight levels, except when defining areas of very flat slope, and are enclosed in a rectangular box. The centre of the box represents the grid point being forecast.



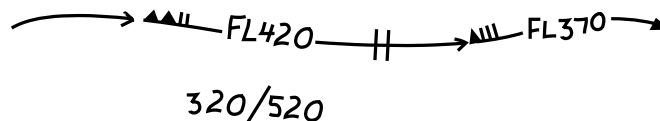

- (d) *jet streams*—the height and speed of jet streams having a core speed of 80 kt or more are shown oriented to true north using arrows with pennants and feathers for speed, and spaced sufficiently close to give a good indication of speed and height changes. A double-hatched line across the jet stream core indicates a speed increase or decrease. The double-hatched line indicates 20 kt changes at 100 kt, 120 kt, 140 kt, or higher. For example, a 120 kt jet stream initially at FL420 dropping to 80 kt at FL370 would be depicted as:

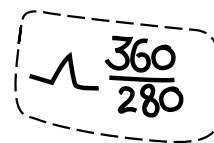

The vertical depth of the jet stream is depicted by two numbers, indicating the height of the 80-kt isotach in hundreds of feet below and above the jet stream. In the above example, the 80-kt isotach is forecast to be at FL320 below and FL520 above the depicted jet stream elevation of FL420. Only jet streams with a speed of 120 kt or more will contain vertical depth information.

- (e) *turbulence*—areas of moderate or severe turbulence in cloud or clear air are depicted using heavy dashed lines, height symbols, a  for moderate turbulence and a  for severe. Wind shear and mountain wave turbulence are included; convective turbulence is not. For example, an area of moderate turbulence between FL280 and FL360 would be shown as:



- (f) *severe squall lines*—severe squall lines are depicted using the symbol  and are oriented to true north with a representative length. An area of frequent CBs associated with a squall line would be shown as:

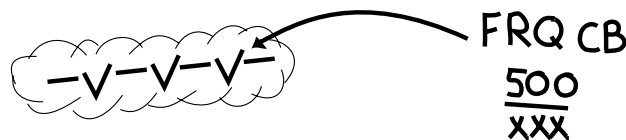

- (g) *icing and hail*—icing and hail are not specifically noted but rather the following statement is included in the label on each chart:

SYMBOL CB IMPLIES HAIL, MODERATE OR GREATER TURBULENCE AND ICING

MET

- (h) *widespread sandstorm or duststorm*—areas of these conditions are shown using a scalloped line, height symbol and a \mathcal{S} . For example:

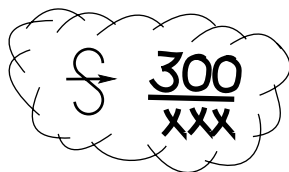

- (i) *tropical cyclones*—the symbol \mathcal{G} is used to depict tropical cyclones and, if any of the previous criteria are met, these will be included. For example, an area of frequent CBs between 10 000 ft and 50 000 ft with an associated tropical storm named “William” would be shown as:



Significant weather prognostic charts depicting the tropical cyclone symbol will have a statement to the effect that the latest tropical cyclone advisory, rather than the tropical cyclone’s prognostic position on the chart, is to be given public dissemination.

- (j) *convergence zones*—well-defined intertropical convergence zones with other associated conditions meeting the previously-stated conditions will be shown within scalloped lines. For example, a convergence zone with one area having frequent CBs topped at FL450 and bases below FL250, and the other area having occasional embedded CBs topped at FL350 and based below the chart level would be shown as:

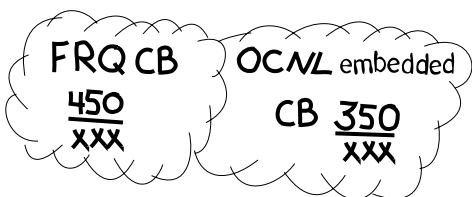

- (k) *frontal positions*—the surface positions of frontal systems associated with significant weather phenomena are shown for the chart’s period of validity using standard frontal symbology along with the speed and direction of movements oriented to true north.

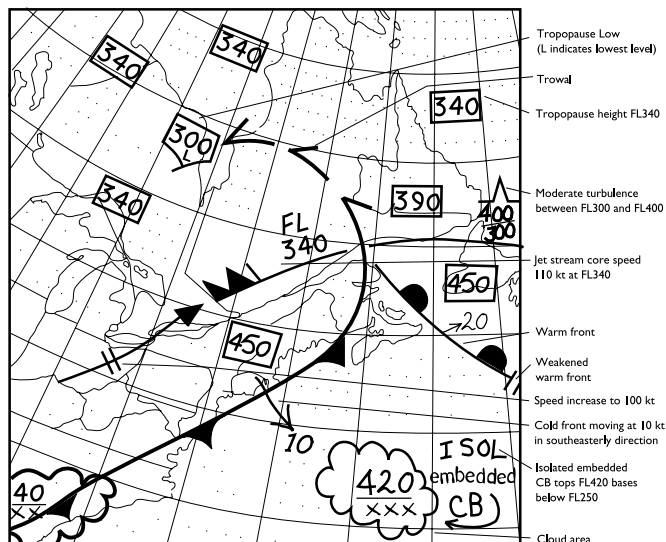

- (l) *volcanic eruption*—information on the location of volcanic eruptions that are producing ash clouds of significance to aircraft operations is shown as follows: the volcanic eruption symbol is shown at the location of the volcano; on the side of the chart, a box is shown containing the volcanic eruption symbol, the name and international number of the volcano (if known), the latitude/longitude, and date and time of the first eruption (if known). Check SIGMET and NOTAM or ASHTAM for volcanic ash. The symbol is as follows:



- (m) *radioactive material in the atmosphere*—information on the location of a release of radioactive materials into the atmosphere that is of significance to aircraft operations is shown as follows: the radioactivity symbol at the site of the accident; on the side of the chart, in a box containing the radioactivity symbol, latitude/longitude of the site of the accident, date and time of the release and a reminder to users to check NOTAM for the area concerned. The symbol is as follows:



MET

3.14 SIGNIFICANT WEATHER PROGNOSTIC CHARTS – CMC

The Canadian Meteorological Centre (CMC) issues a series of significant weather prognostic charts for the lower levels 700 to 400 mb (FL100 to FL240). They use the same criteria as above, plus the following:

- (a) moderate to severe icing;
- (b) cloud layers of significance;
- (c) marked mountain waves;
- (d) freezing level line (0°C) at 5 000-ft intervals, and labeled in hundreds of feet; and/ or
- (e) surface positions and direction of motion (in kt) of highs, lows, and other significant features (front, trough).

Symbols used on the Significant Weather Prognostic Charts by the CMC:

SIGNIFICANT WEATHER SYMBOLS

	Boundary of an Area of Significant Cloud		Boundary of an Area of Turbulence
	Moderate Turbulence *		Thunderstorm
	Severe Turbulence *		Severe Line Squall
	Light Icing *		Hurricane
	Moderate Icing *		Tropical Storm
	Severe Icing *		Dust or Sand Storm

* an abbreviation for the type of turbulence, or icing is placed below the symbol (for ex. CAT for clear air turbulence, or MXD for Mixed Icing).

CLOUD		
Cloud types are represented by the conventional abbreviation, cloud amount are indicated as BKN or OVC, and height of base and tops by the convention illustrated:	BKN AC 240	Alto cumulus, base below chart level, tops 24 000 feet.
	XX	

* ABBREVIATIONS

CAT	– clear air turbulence
ISOL	– isolated
FRQ	– frequent
LYR	– layers
MXD	– mixed
OCNL	– occasional
LEE WV	– lee/mountain waves
CLR	– clear
FZLVL	– freezing level

FRONTS AND OTHER CONVENTIONS

	Warm front		Occlusion		Trough of warm air aloft
	Cold front		Quasistationary front		Upper Trough
	Mean Sea Level Isobars, pressure in millibars		0°C Isotherm height in hundreds of ft.		Trough line

3.15 AVIATION ROUTINE WEATHER REPORT – METAR

3.15.1 The METAR Code

An aerodrome report describes the actual weather conditions at a specified location and at a specified time as observed from the ground. METAR is the name of the international meteorological code for an aerodrome routine meteorological report. METAR observations are normally taken and disseminated on the hour. A SPECI, the name of the code for an aerodrome special meteorological report, will be reported when weather changes of significance to aviation are observed (see MET 3.15.4).

In Canada, METARs and SPECIs are not encoded by the observer, but are generated by computer software, based on hourly or special observations taken at either staffed or automatic sites.

The code is composed of several groups which are always in the same relative position to one another. When a weather element or phenomenon does not occur, the corresponding group (or extension) is omitted. Certain groups may be repeated.

The large majority of METARs and SPECIs are provided by NAV CANADA; however, at DND aerodromes they are provided by DND. If METARs and SPECIs are being provided by another source, they will be indicated as being “private” in the CFS. For these sites, the aerodrome operator is the primary contact for further information.

3.15.2 National Variations

Despite the fact that METAR is an international code, there are some national variations. For example, wind speed may be reported in different units; however, the units are always appended to the values to avoid any misunderstanding. A detailed account of the differences that Canada has filed with the World Meteorological Organization (WMO) may be found in the WMO *Manual on Codes*, Volume II, Regional Codes and National Coding Practices (No. 306). (See MET 1.1.7 for ordering and MET 1.1.8 for differences from ICAO Annex 3.)

3.15.3 Sample Message

```
METAR CYXE 292000Z CCA 30015G25KT 3/4SM
R33/4000FT/D -SN BLSN BKN008 OVC040 M05/M08
A2992 REFZRA REWS RWY33 RMK SF5 SC3 VIS 3/8 TO
NW SLP134
```

- (a) *Decoding of example*—Aerodrome routine meteorological report; Saskatoon, Saskatchewan, issued on the 29th day of the month at 2000 UTC; first correction to the original observation; wind 300° true, 15 kt with gusts to 25 kt; visibility 3/4 SM; runway visual range for Runway 33 is 4 000 ft and has had a downward tendency; present weather is light snow and moderate blowing snow; broken

METAR

clouds at 800 ft AGL, and combined with the lower layer, overcast clouds at 4 000 ft; temperature minus 5°C; dew point minus 8°C; altimeter setting 29.92 in of mercury; recent freezing rain; recent wind shear Runway 33; Remarks: stratus fractus 5/8, stratocumulus 3/8, visibility to the northwest 3/8 SM, sea level pressure 1013.4 hPa.

(b) *Report type*—The code name METAR (or SPECI) is given in the first line of text. A SPECI is issued only when significant changes in weather conditions occur off the hour.

(c) *Location indicator*—Canadian aviation weather reporting stations are assigned four-character ICAO indicators commencing with C and followed by either W, Y, or Z. These stations are normally located within 1.6 NM (3 km) of the geometric centre of the runway complex. Aviation weather reporting sites are listed in the CFS.

(d) *Date/time of observation*—The date (day of the month) and time (UTC) of the observation is included in all reports. The official time of the observation (on the hour) is used for all METARs that do not deviate from the official time by more than 10 min. In SPECIs, the time refers to the time of occurrence (hours and minutes) of the change(s) which required the issue of the report.

(e) *Report modifier*—This field may contain two possible codes: “AUTO” or “CCA”. Both codes may appear simultaneously, i.e. “AUTO CCA”. “AUTO” is used when data for the primary report is gathered by an AWOS. See MET 3.15.5 for more information about AWOS reports. “CCA” is used to indicate corrected reports. The first correction is indicated as CCA, the second as CCB, etc.

(f) *Wind*—This group reports the 2-minute mean wind direction and speed, along with gusts. Wind direction is always three digits, given in degrees (true) but rounded off to the nearest 10 degrees (the third digit is always a “0”). Wind speeds are two digits (or three digits if required), in knots. Calm is encoded as “0000KT”. In Canada the unit for wind speed is knots (nautical miles per hour) and is indicated by including “KT” at the end of the wind group. Other countries may use kilometres per hour (KMH), or metres per second (MPS).

(i) *Wind gusts*—Gust information will be included if gust speeds exceed the average wind speed by 5 kt or more in the 10-minute period preceding the observation and the peak gust reaches a maximum speed of 15 kt or more. “G” indicates gusts and the peak gust is reported, using two or three digits as required.

(ii) *Variations in wind direction:*

Example: `METAR CYWG 172000Z 30015G25KT
260V340`

This group reports variations in wind direction. It is only included if, during the 10-minute period preceding the observation, the direction

varies by 60 degrees or more and the mean speed exceeds 3 kt. The two extreme directions are encoded in clockwise order. In the example above, the wind is varying from 260 degrees (true) to 340 degrees (true).

(g) *Prevailing visibility*—The prevailing visibility is reported in statute miles and fractions. There is no maximum visibility value reported. Lower sector visibilities which are half or less of the prevailing visibility are reported as remarks at the end of the report.

(h) *Runway visual range*—The runway visual range for the touchdown zone of up to four available landing runways is reported as a 10-minute average, based on the operational runway light settings at the time of the report. It is included if the prevailing visibility is 1 statute mile or less, and/or the runway visual range is 6000 ft or less. “R”, the group indicator, is followed by the runway designator (e.g., “06”), to which may be appended the letters “L”, “C”, or “R” (left, centre, or right) if there are two or more parallel runways. The value of runway visual range is then reported in hundreds of feet, using three or four digits. FT indicates the units for runway visual range are feet. “M” preceding the lowest measurable value (or “P” preceding the highest) indicates the value is beyond the instrument range. The runway visual range trend is then indicated if there is a distinct upward or downward trend from the first to the second 5-minute part-period such that the runway visual range changes by 300 ft or more (encoded “/U” or “/D” for upward or downward) or if no distinct change is observed, the trend “/N” is encoded. If it is not possible to determine the trend the field will be left blank.

(i) *Variations in runway visual range*—Two runway visual range values may be reported, the minimum and maximum one-minute mean runway visual range values during the 10-minute period preceding the observation, if they vary from the 10-minute mean by at least 20% (and by 150 feet).

Example: “R06L/1000V2400FT/U” decodes as: the minimum runway visual range for Runway 06 Left is 1000 ft; the maximum runway visual range is 2400 ft; and the trend is upward.

(j) *Present weather*—The present weather is coded in accordance with the *World Meteorological Organization (WMO) Code*, Table 4678, which follows. As many groups as necessary are included, with each group containing from 2 to 9 characters.

Present weather is comprised of weather phenomena, which may be one or more forms of precipitation, obscuration, or other phenomena. Weather phenomena are preceded by one or two qualifiers; one of which describes either the intensity or proximity to the station of the phenomena, the other of which describes the phenomena in some other manner.

WMO Code, Table 4678
(incorporating Canadian differences)
SIGNIFICANT PRESENT WEATHER CODES

QUALIFIER		WEATHER PHENOMENA							
INTENSITY or PROXIMITY 1	DESCRIPTOR 2		PRECIPITATION 3		OBSCURATION 4		OTHER 5		
Note: Precipitation intensity refers to all forms combined.	MI	Shallow	DZ	Drizzle	BR	Mist (Vis ≥ 5/8 SM)	PO	Dust/sand Whirls (Dust Devils)	
	BC	Patches	RA	Rain					
	PR	Partial	SN	Snow	FG	Fog (Vis < 5/8 SM)	SQ	Squalls	
	DR	Drifting	SG	Snow Grains	FU	Smoke (Vis ≤ 6 SM)	+FC	Tornado or Waterspout	
- Light	BL	Blowing	IC	Ice Crystals (Vis ≤ 6 SM)	DU	Dust (Vis ≤ 6 SM)	FC	Funnel Cloud	
	SH	Shower(s)							
Moderate (no qualifier)	TS	Thunderstorm	PL	Ice Pellets	SA	Sand (Vis ≤ 6 SM)	SS	Sandstorm (Vis < 5/8 SM) (+SS Vis < 5 16 SM)	
			GR	Hail					
+Heavy	FZ	Freezing	GS	Snow Pellets	HZ	Haze (Vis ≤ 6 SM)	DS	Duststorm (Vis < 5/8 SM) (+DS Vis < 5 16 SM)	
VC In the vicinity			UP	Unknown precipitation (AWOS only)	VA	Volcanic Ash (with any visibility)			

MET

(k) *Qualifiers:*

Intensity (–) *light* (no sign) *moderate* (+) *heavy*

If the intensity of the phenomena being reported in a group is either light or heavy, this is indicated by the appropriate sign. No sign is included if the intensity is moderate, or when an intensity is not relevant.

If more than one type of precipitation is reported together in a group, the predominant type is given first; however, the reported intensity represents the “overall” intensity of the combined types of precipitation.

(l) *Proximity:*

The proximity, qualifier “VC”, is used in conjunction with the following phenomena:

- SH* (showers);
- FG* (fog);
- BLSN, BLDU, BLSA* (blowing snow, blowing dust, blowing sand);
- PO* (dust/sand whirls);
- DS* (duststorm);
- SS* (sandstorm)

“VC” is used if these phenomena are observed within 5 SM, but not at the station. When VC is associated with “SH”, the type and intensity of precipitation is not specified because it cannot be determined.

(m) *Descriptor* — No present weather group has more than one descriptor.

The descriptors *MI* (shallow), *BC* (patches) and *PR* (partial) are used only in combination with the abbreviation *FG* (fog), e.g., “MIFG”.

The descriptors *DR* (drifting) and *BL* (blowing) are used only in combination with *SN* (snow), *DU* (dust) and *SA* (sand). Drifting is used if the snow, dust or sand is raised less than two metres above ground; if two metres or more, blowing is used. If blowing snow (*BLSN*) and snow (*SN*) are occurring together, both are reported but in separate present weather groups, e.g., “SN BLSN”.

SH (shower) is used only in combination with precipitation types *RA* (rain), *SN* (snow), *PL* (ice pellets), *GR* (hail) and *GS* (snow pellets) if occurring at the time of observation, e.g., “SHPL” or “–SHRAGR”.

TS (thunderstorm) is either reported alone or in combination with one or more of the precipitation types. The end of a thunderstorm is the time at which the last thunder was heard, followed by a 15-minute period with no further thunder.

NOTE: *TS* and *SH* are not used together, since present weather groups can have only one descriptor. *FZ* (freezing) is used only in combination with the weather types *DZ* (drizzle), *RA* (rain) and *FG* (fog).

(n) *Weather Phenomena:*

Different forms of *precipitation* are combined in one group, the predominant form being reported first. The intensity qualifier selected represents the overall intensity of the entire group, not just one component of the group

The one exception is freezing precipitation (*FZRA* or *FZDZ*), which is always reported in a separate present weather group.

Obstructions to vision are generally reported if the prevailing visibility is 6 SM or less, with some exceptions.

Any obscuration occurring simultaneously with one or more forms of precipitation is reported in a separate present weather group.

Other phenomena are also reported in separate groups, and, when funnel clouds, tornados or waterspouts are observed, they will be coded in the present weather section, as well as being written out in their entirety in remarks.

(o) *Sky conditions*—This group reports the sky condition for layers aloft. A vertical visibility (*VV*) is reported in hundreds of feet when the sky is obscured. All cloud layers are reported based on the summation of the layer amounts as observed from the surface up, reported as a height above the station elevation in increments of 100 ft to a height of 10 000 ft, and thereafter in increments of 1 000 ft. The layer amounts are reported in eighths (oktas) of sky coverage as follows:

SKC	"sky clear"	no cloud present
FEW	"few"	>0 to 2/8 summation amount
SCT	"scattered"	3/8 to 4/8 summation amount
BKN	"broken"	5/8 to <8/8 summation amount
OVC	"overcast"	8/8 summation amount
CLR	"clear"	clear below 10 000 ft as interpreted by an autostation

Significant convective clouds (cumulonimbus or towering cumulus only), if observed, are identified by the abbreviations *CB* (cumulonimbus) or *TCU* (towering cumulus) appended to the cloud group without a space, e.g. “SCT025TCU”. Where observed, other cloud types and their layer opacity are reported in the remarks.

The AWOS cannot report cloud types; cloud layers are limited to four, and will report clear (*CLR*) when no layers are detected below a base of 25 000 ft (legacy and some private AWOS are limited to 10 000-ft cloud bases).

A *cloud ceiling* is said to exist at the height of the first layer for which a coverage symbol of BKN or OVC is reported. The existence of a vertical visibility constitutes an obscured ceiling.

- (p) *Temperature and dew point*—This group reports the air temperature and the dew point temperature, rounded to the nearest whole Celsius degree (e.g., +2.5°C would be rounded to +3°C). Negative values are preceded by the letter M, and values with a tenths digit equal to precisely 5 (e.g., 2.5, -0.5, -1.5, -12.5 etc.) are rounded to the warmer whole degree.
- (q) *Altimeter setting*—This group reports the altimeter setting. A is the group indicator, followed by the altimeter setting indicated by a group of four figures representing tens, units, tenths and hundredths of inches of mercury. To decode, place a decimal point after the second digit (e.g., A3006 becomes 30.06).
- (r) *Recent weather*—This group reports recent weather of operational significance. The group indicator RE is followed, without a space, by the appropriate abbreviation(s) for weather observed during the period since the last (scheduled) routine report (“METAR”), but not observed at the time of observation. Recent weather is included in “METAR” and “SPECI” reports.

The following may be reported as recent weather phenomena:

- freezing precipitation;
- moderate or heavy drizzle, rain or snow;
- moderate or heavy ice pellets, hail or snow pellets;
- moderate or heavy blowing snow;
- sandstorm or duststorm;
- tornado, waterspout or funnel cloud;
- thunderstorm; or
- volcanic ash.

The same phenomenon is only reported as present weather and recent weather if it was of greater intensity during the period since the last routine report. For example, with a moderate rainshower at 1800Z and a heavy rainshower at 1700Z (or later), the 1800Z METAR would report “SHRA” in present weather and “RERA” in the recent weather group.

- (s) *Wind shear*—This group contains reports of low level wind shear (within 1600 feet AGL) along the takeoff or approach path of the designated runway. The two number runway identifier is used, to which the letters “L”, “C”, or “R” may be appended. If the existence of wind shear applies to all runways, “WS ALL RWY” is used.
- (t) *Remarks*—Remarks will appear in reports from Canada, prefaced by RMK. Remarks will include, where observed, layer type and opacity in eighths of sky concealed (oktas) of clouds and/or obscuring phenomena, general weather remarks, and sea level pressure, as required. The sea level pressure, indicated in hectopascals, will always be the last

field of the METAR report, prefixed with “SLP”.

Abbreviations for cloud types:

CI = cirrus	NS = nimbostratus
CS = cirrostratus	ST = stratus
CC = cirrocumulus	SF = stratus fractus
AS = altostratus	SC = stratocumulus
AC = altocumulus	ACC = altocumulus castellanus
CU = cumulus	CUFRA = cumulus fractus
TCU = towering cumulus	CB = cumulonimbus

3.15.4 Aerodrome Special Meteorological Reports (SPECI)

Criteria for Taking Special Weather Reports

Special observations will be taken promptly to report changes that occur between scheduled transmission times whenever one or more of the following elements have changed in the amount specified. The amount of change is with reference to the preceding routine or special observation.

- (a) *Ceiling*: The ceiling decreases to less than, or increases to equal or exceed the following values of height:
 - (i) 1 500 ft
 - (ii) 1 000 ft
 - (iii) 500 ft
 - (iv) 400 ft*
 - (v) 300 ft
 - (vi) 200 ft*
 - (vii) 100 ft*
 - (viii) the lowest published minimum

Criteria marked with an asterisk (*) are applicable only at aerodromes with precision approach equipment (e.g. ILS, MLS, ground controlled approach [GCA]), and only down to and including the lowest published minima for those aerodromes.

- (b) *Sky condition*: A layer aloft is observed below 1 000 ft and no layer aloft was reported below this height in the report immediately previous, or below the highest minimum for IFR straight-in landing or takeoff, and no layer was reported below this height in the report immediately previous.

- (c) *Visibility*: Prevailing visibility decreases to less than, or increases to equal or exceed:
 - (i) 3 SM
 - (ii) 1 1/2 SM
 - (iii) 1 SM
 - (iv) 3/4 SM
 - (v) 1/4 SM*
 - (vi) the lowest published minimum

Criteria marked with an asterisk (*) are applicable only at aerodromes with precision approach equipment (i.e. ILS, MLS, ground controlled approach [GCA]), and only down to and including the lowest published minima for these aerodromes.



(d) *Tornado, waterspout or funnel cloud:*

- (i) is observed;
- (ii) disappears from sight; or
- (iii) is reported by the public (from reliable sources) to have occurred within the preceding six hours and not previously reported by another station.

(e) *Thunderstorm:*

- (i) begins;
- (ii) intensity increases to become “heavy” ; or
- (iii) ends (a SPECI shall be made when 15 min have elapsed without the occurrence of thunderstorm activity).

(f) *Precipitation:*

- (i) hail begins or ends;
- (ii) freezing rain, freezing drizzle or non-showery ice pellets begin, end or change intensity;
- (iii) rain, drizzle, snow, snow grains, snow pellets, showery ice pellets or ice crystals begin or end;
- (iv) moderate or heavy precipitation begins, ends or changes in intensity (including showers);
- (v) special observations shall be taken as required to report the beginning and ending of each individual type of precipitation, regardless of simultaneous occurrences of other types. A leeway of up to 15 min is allowed after the ending of precipitation before a SPECI is mandatory;
- (vi) changes in character of precipitation do not require a special observation if the break in precipitation does not exceed 15 min (e.g. rain changes to rain showers or vice versa).

Example: *–RA to RASH; SPECI not required.*

(g) *Wind:*

- (i) speed (2 min mean) increases suddenly to at least double the previously reported value and exceeds 30 kt;
- (ii) direction changes sufficiently to fulfill criteria required for a “wind shift.”

(h) *Temperature:*

- (i) increases by 5°C or more from the previous reported value and the previous reported value was 20°C or higher; or
- (ii) decreases to a reported value of 2°C or lower.

Local Criteria

Additional criteria may be established to meet local requirements.

Observer’s Initiative

The criteria specified in the preceding paragraphs shall be regarded as the minimum requirements for taking special observations. In addition, any weather condition that, in the opinion of the observer is important for the safety and efficiency of aircraft operations, or otherwise significant, shall be reported by a special observation.

Check Observations

Check observations are taken between regular hourly observations to ensure that significant changes in weather do not remain unreported. If such an observation does not reveal a significant change, it is designated as a “check observation.” If a significant change has occurred, the report is treated as a “special observation.”

A check observation shall be taken whenever a PIREP is received from an aircraft within 1 1/2 SM of the boundary of an airfield, and the PIREP indicates that weather conditions, as observed by the pilot, differ significantly from those reported by the current observation (i.e. the PIREP indicated that a special report may be required). This check observation should result in one of the following:

- (a) transmission of a special observation over regular communications channels; or
- (b) if no special observation is warranted, transmission of the check observation, together with the PIREP, to local airport agencies.

The following airports have been identified for SPECI criteria for significant temperature changes between hourly reports:

- Calgary Intl, Alta.
- Edmonton Intl, Alta.
- Gander Intl, N.L.
- Moncton/Greater Moncton Intl, N.B.
- Montréal/Pierre Elliott Trudeau Intl, Que.
- Montréal Intl (Mirabel), Que.
- Ottawa/Macdonald-Cartier Intl, Ont.
- St. John’s Intl, N.L.
- Toronto/Lester B. Pearson Intl, Ont.
- Vancouver, B.C.
- Victoria Intl, B.C.
- Halifax Intl, N.S.
- London, Ont.
- Québec/Jean Lesage Intl, Que.
- Whitehorse Intl, Y.T.
- Winnipeg Intl, Man.
- Yellowknife, N.W.T.
- Charlottetown, P.E.I.
- Fredericton, N.B.
- Prince George, B.C.
- Regina Intl, Sask.
- Saint John, N.B.
- Saskatoon/John G. Diefenbaker Intl, Sask.
- Thunder Bay, Ont.

3.15.5 Reports from Automated Weather Observation Systems (AWOS)

Various combinations of automated meteorological sensors have been generating weather observation data in Canada since 1969. Most of the early autostations had characteristics that did not permit use of their reports for aviation.

AWOS was developed to provide an alternative method of collecting and disseminating weather observations from sites where human observation programs could not be supported. AWOS provides highly accurate and reliable data, but it does have limitations and idiosyncrasies that are important to understand when using the information.

The aviation AWOS is a modular system that currently incorporates sensors capable of measuring cloud-base height (up to 10 000 ft AGL); sky cover; visibility; temperature; dew point; wind velocity; altimeter setting; precipitation occurrence, type, amount, and intensity; and the occurrence of icing. It incorporates fail-safe dual atmospheric pressure sensors for determining altimeter setting that will shut down if there are significant discrepancies between the two sensors. Some systems are equipped with a voice generator module (VGM) and VHF transmitter.

The AWOS observations, which use the word “*AUTO*” to indicate an automated observation, are reported in the normal METAR/SPECI format. “*METAR AUTO*” observations are reported on the hour and “*SPECI AUTO*” observations are issued to report significant changes in cloud ceiling, visibility and wind velocity, as well as the onset and cessation of precipitation or icing.

The AWOS sensors sample the atmosphere and prepare a data message every minute. If the weather conditions have changed significantly enough to meet the SPECI criteria, and subject to the various processing algorithms, a SPECI will be issued. Human observers view the entire celestial dome and horizon; this results in a naturally SMOOTHED and more representative value for ceiling and visibility. Because of the precise measurement, continuous sampling and unidirectional views of the AWOS, it will produce more SPECI observations than staffed sites (5%–6% of the time AWOS SPECI counts exceed 6 per hour). In cases where there are several AWOS reports issued over a short period of time, it is important to summarize the observations to gain an appreciation of the weather trend. One report in a series should not be expected to represent the prevailing condition. There are other peculiarities of the AWOS observation. A comparison of human observations and AWOS appears in the table below.

OBSERVATION COMPARISON TABLE		
WX Report Parameter	Human Observation	AWOS Observation
Report type	METAR or SPECI	METAR or SPECI
Location indicator	Four-letter indicator (e.g., CYQM, CYVR).	No difference.
	At stations where the observer is not on the aerodrome, (beyond 1.6 NM (3 km) of the geometric centre of the runway complex) the Wx report indicator differs from the aerodrome indicator, e.g., Dease Lake aerodrome is CYDL; the Wx report is identified as CWDL.	All AWOS are located on aerodromes.
Report time	Date and time in UTC, followed by a “Z”, e.g. 091200Z.	No difference.
AWOS indicator		AUTO
Corrections indicator	Corrections can be issued, e.g., “CCA”, the “A” indicates the first correction.	No difference.
Wind	A two-minute average direction in degrees true, speed in kt, “G” represents a gust, e.g. 12015G25KT.	No difference.
	If wind information is missing, five forward slashes (/) are placed in the wind field, e.g., /////.	No difference. NOTE: When a VGM is installed, the wind direction will be broadcast in degrees Magnetic if the AWOS is located in Southern Domestic Airspace, elsewhere it will be broadcast in degrees true.
Variable wind group	Wind direction variation of 60° or greater	Not reported in the AWOS METAR or SPECI message.



OBSERVATION COMPARISON TABLE

WX Report Parameter	Human Observation	AWOS Observation
Visibility	Reported in statute miles (SM) up to 15 miles. After 15 miles, it is reported as 15+, e.g., 10SM.	Reported in statute miles (SM) up to 9 miles.
	Fractional visibilities are reported.	No difference.
	Visibility is prevailing visibility, i.e., common to at least half the horizon circle.	Visibility is measured using fixed, unidirectional, forward scatter techniques. .
		Reported visibilities tend to be comparable to (especially with visibility less than 1 SM) or higher than human observations in precipitation.
	Reported visibilities at night are the same as the day and tend to be comparable to or higher than human observations.	
Runway visual range	Runway direction, followed by the visual range in feet, followed by a trend. Runway visual range will be reported where equipment is available.	Not currently reported by AWOS.
Weather group	See the table following MET 3.15.3(j) for the symbols used for obstructions to visibility (e.g., smoke, haze).	Obstructions to visibility are not identified in the AWOS reports; therefore, the reason for reduced visibility may not be apparent. Consult the graphic area forecast (GFA) or aerodrome forecast (TAF).
	See the table following MET 3.15.3(j) for the symbols used for the description of weather.	AWOS will report weather phenomena using the following symbols: RA, DZ—rain, drizzle FZRA—freezing rain, FZDZ—freezing drizzle GR—hail SN—snow UP—unknown precipitation type
	"+" or "-" is used to indicate weather intensity.	No difference. Squalls are not reported. AWOS does not report "in the vicinity" phenomena.
		AWOS may sporadically report freezing precipitation at temperatures above 0 and below +10 degrees Celsius, during periods of either wet snow, rain, drizzle or fog.

MET

OBSERVATION COMPARISON TABLE			
WX Report Parameter	Human Observation	AWOS Observation	
Cloud amount and sky conditions	Observer views entire celestial dome and determines cloud-base height, layer amounts and opacity, and cumulative amount and opacity.	Laser ceilometer views one point directly over the station. It measures the cloud-base height, then uses time integration to determine layer amounts.	
	<i>SKC</i> or height of cloud base plus <i>FEW, SCT, BKN, OVC</i> .	Height of cloud base plus <i>FEW, SCT, BKN, OVC</i> . Cloud-height measurement is possible only to 10 000 ft AGL. " <i>CLR</i> " is reported if no cloud below 10 000 ft AGL is detected.	
	Surface-based layers are prefaced by " <i>VV</i> " and a three-figure vertical visibility.	No difference.	
	The cloud layer amounts are cumulative.		No difference.
			Ceilometer may occasionally report the true occurrence of multiple overcast layers.
			Multiple overcast layers can be detected and reported by the ceilometer.
			Ceilometer may occasionally detect ice crystals or strong temperature inversion aloft and report them as cloud layers. Check GFA and TAF for further information.
			Reported cloud layers in precipitation are comparable to or lower than human observations.
		On rare occasions, the laser ceilometer may report <i>CLR</i> during reduced visibility and precipitation situations—a report of sky <i>CLR</i> may be false.	
		Check the TAF and the GFA for further information.	
Temperature and dew point.	Temperature then dew point expressed as a two-digit number in degrees Celsius, separated by a forward slash (/) and preceded by an "M" for below freezing temperatures, e.g., <i>03/M05</i> .	No difference.	
Altimeter setting	An "A" followed by a four-digit number in inches of mercury. e.g., <i>A2997</i> .	No difference.	
Recent weather	Recent weather of operational significance, but not occurring at the time of the observation, shall be reported.	Not reported in the AWOS METAR or SPECI message. The VGM is capable of reporting recent freezing precipitation.	
Wind shear	Existence in the lower layers shall be reported	Not reported by AWOS.	
Supplementary information (Remarks)	See the table in MET 3.15.3(j) for the symbols used to describe clouds and obscuring phenomena.	Clouds and obscuring phenomena are not described in METAR AUTO or SPECI AUTO reports.	
	<i>Significant weather or variation not reported elsewhere in the report.</i>	Currently, "Remarks" are limited. When the visibility is variable, the remark " <i>VIS VRB</i> " followed by the limits will appear, e.g., <i>VIS VRB 0.5V3.0</i> (visibility reported in tenths). When icing is detected, " <i>ICG</i> ", " <i>ICG INTMT</i> " or " <i>ICG PAST HR</i> " will appear. Remarks on precipitation amount, rapid changes in pressure may also appear.	
Barometric pressure	The last remark in the METAR or SPECI is the mean sea level pressure in hectopascals, e.g., <i>SLP127</i> (1012.7 hPa).	No difference.	

MET

The following compares a routine observation made from a human observer with the equivalent observation that might have been made by an AWOS.

Human METAR/SPECI Observation

*METAR CYEG 151200Z CCA 12012G23KT 3/4SM R06R/4000FT/D
-RA BR FEW008 SCT014 BKN022 OVC035 10/09 A2984 RETSRA
RMK SF1SC2SC4SC1 VIS W2 SLP012=*

AWOS METAR AUTO/SPECI AUTO Observation

*METAR CYEG 151200Z AUTO CCA 12012G23KT 3/4SM -RA
FEW008 SCT014 BKN022 OVC035 10/09 A2984 RMK SLP012=*

NOTE: If an AWOS sensor is malfunctioning or has shut down, that report parameter will be missing from the METAR AUTO or SPECI AUTO.

3.15.6 Other Automated Reports

3.15.6.1 LWIS

LWIS is for use at aerodromes where provision of a full surface weather observation program is not justified, but support for a CAP approach is required.

LWIS comprises automated meteorological sensors, a data processing system, a communication system, and, at some sites, a voice generator sub-system (VGSS) with VHF transmitter. For some LWIS, including all those operated by NAV CANADA, the on-the-hour data collection is coded and disseminated as an hourly, limited weather observation. SPECI observations are only issued by LWIS for wind shifts.

LWIS reports wind direction, speed and gust; air temperature; dew point; and altimeter setting, which has failsafe sensors. Some private LWIS may report additional weather elements; however, no automated system that reports fewer than the standard four elements should be referred to as an LWIS. The wind direction is reported in degrees true, unless using the VGSS, which is reported in degrees Magnetic in SDA.

An example of an LWIS message is:

LWIS CWDL 291700Z AUTO 25010G15KT 03/M02 A3017=

3.15.6.2 Voice Generator Module Reports

Where a VGM, VHF radio and/or telephone are connected to the AWOS or LWIS, the most recent data gathered once each minute will be broadcast to pilots on the VHF frequency and/or by calling the telephone number published in the *Canada Flight Supplement* (CFS). A pilot with a VHF receiver should be able to receive the VGM transmission at a range of 75 NM from the site at an altitude of 10 000 ft AGL. Weather data will be broadcast in the same sequence as that used for METARs and SPECIs.

The human-observed METAR or SPECI shall take priority over the AWOS or LWIS VGM report. During the hours when a human observation program is operating and there is no direct VHF communication between the pilot and weather observer, the VGM VHF transmitter will normally be off. This will eliminate the risk of a pilot possibly receiving two contradictory and confusing weather reports.

In variable weather conditions, there may be significant differences between broadcasts only a few minutes apart. It is very important during these conditions to obtain several broadcasts of the minutely data for comparison to develop an accurate picture of the actual conditions to be expected at the location.

Below is the typical format of an AWOS VGM message:

*“(site name) AUTOMATED WEATHER OBSERVING SYSTEM—
CURRENT OBSERVATION TAKEN AT (time) UNIVERSAL – WIND
(direction) (MAGNETIC/TRUE) (speed) KNOTS – VISIBILITY
(visibility data) STATUTE MILES – (present weather data) –
(sky condition/cloud data) – TEMPERATURE (temperature
data) CELSIUS – DEW POINT (dew point data) CELSIUS –
ALTIMETER (altimeter data) INCHES”*

Below is an example of the LWIS VGM message:

*“(site name) LIMITED WEATHER INFORMATION SYSTEM—
CURRENT OBSERVATION TAKEN AT (time) UNIVERSAL – WIND
(direction) (MAGNETIC/TRUE) (speed) KNOTS – TEMPERATURE
(temperature data) CELSIUS – DEW POINT (dew point data)
CELSIUS – ALTIMETER (altimeter data) INCHES”*

NOTE: Missing data or data that has been suppressed is transmitted as “MISSING”

3.16 EC/DND WEATHER RADAR NETWORK

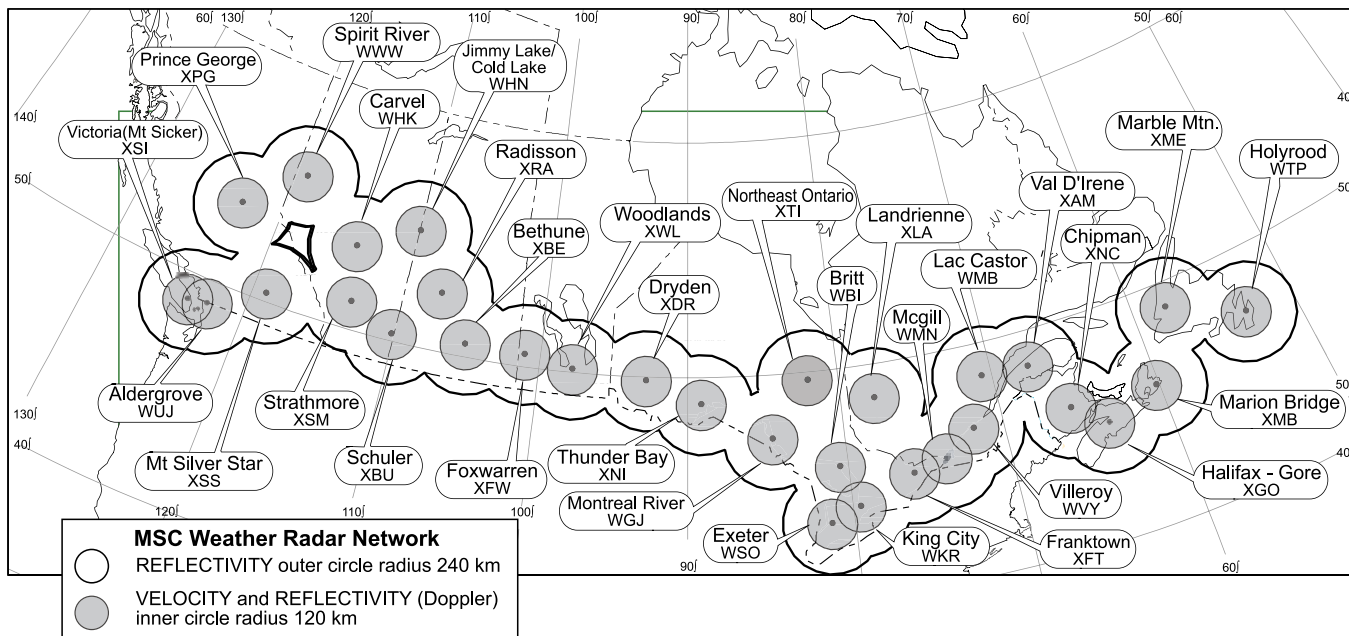

3.17 PIREP

General

PIREPs are reports of weather conditions encountered by aircraft during flight. PIREPs are extremely useful to other pilots, aircraft operators, weather briefers and forecasters, as they supplement weather information received from meteorological observing stations. Pilots are encouraged to file brief reports of weather conditions when giving position reports, especially reports of any significant atmospheric phenomena. PIREPs received by flight service personnel are immediately disseminated on meteorological communications circuits and provided to other ATS units and the Canadian Meteorological Aviation Centres (CMAC).

Example:

UACN10 CYXU 032133 YZ UA /OV YXU 090010 /TM 2120 /FL080 /TP PA31 /SK 020BKN040 1100VC /TA -12 /WV 030045 /TB MDT BLO 040 /IC LGT RIME 020-040 /RM NIL TURB CYYZ-CYHM

PIREP EXAMPLE	DECODED EXAMPLE
UACN10	<i>Message Type:</i> Regular PIREP. Urgent PIREPs are encoded as UACN01.
CYXU	<i>Issuing office:</i> London flight information centre (FIC).
032133	<i>Date/Time of Issue:</i> 3rd day of the month, at 2133Z.
YZ	<i>Flight Information Region (FIR):</i> Toronto FIR. If the PIREP extends into an adjacent FIR, both FIRs will be indicated.

PIREP EXAMPLE	DECODED EXAMPLE
UA /OV YXU 090010	<i>Location:</i> London VOR 090° radial, 10 NM. PIREP location will be reported with reference to a NAVAID, airport or geographic coordinates (latitude/ longitude).
/TM 2120	<i>Time of PIREP:</i> 2120Z
/FL080	<i>Altitude:</i> 8 000 ft ASL. Altitude may also be reported as "DURD" (during descent), "DURC" (during climb) or "UNKN" (unknown).
/TP PA31	<i>Aircraft Type:</i> Piper Navajo (PA31).
/SK 020BK N040 1100VC	<i>Sky Cover:</i> First layer of cloud based at 2 000 ft with tops at 4 000 ft ASL. Second layer of cloud based at 11 000 ft ASL.
/TA -12	<i>Air Temperature:</i> -12°C.
/WV 030045	<i>Wind Velocity:</i> Wind direction 030 degrees true, wind speed 45 kt. Wind direction reported by pilots in degrees magnetic will subsequently be converted to degrees true for inclusion in PIREP.
/TB MDT BLO 040	<i>Turbulence:</i> Moderate turbulence below 4 000 ft ASL.
/IC LGT RIME 020-040	<i>Icing:</i> Light rime icing (in cloud) between 2 000 ft ASL and 4 000 ft ASL.
/RM NIL TURB CYYZ-CYHM	<i>Remarks:</i> No turbulence encountered between Toronto and Hamilton.

NOTE: Supplementary information for any of the PIREP fields may be included in the remarks (RM) section of the PIREP.

MET

3.18 SIGMET

General

These messages are intended to provide short-term warnings of certain potentially hazardous weather phenomena. The list of phenomena is limited by international agreement to the more serious hazards which are important to all types of aircraft.

Warnings are issued for active thunderstorm areas, lines of thunderstorms, heavy hail, severe turbulence or icing,

marked mountain waves, hurricanes, widespread sand or dust storms, volcanic ash, and low level windshear. SIGMETs are broadcast on the appropriate IFR and VFR ATS frequencies upon receipt. Each SIGMET weather phenomenon is coded with a letter and number that is unique to the SIGMETs issued by that regional weather forecast centre. Successively higher numbers supersede SIGMETs previously issued by that weather forecast centre for a given letter code. Meteorological reference points that may be used in SIGMET and AIRMET are outlined in MET 3.5.

EXAMPLE	DECODE OF EXAMPLE
WSCN33 CWTO 171805	This SIGMET was issued by the Toronto Forecast Centre to describe weather phenomena in the graphic area forecast area 33 (GFACN 33) on the 17th day of the month at 1805 UTC.
SIGMET A5 VALID 171805/172205 CWTO	This SIGMET (Alfa 5) supersedes its predecessor (Alfa 4), which was issued by the same weather centre to describe the same weather phenomenon within that GFA area. The SIGMET is valid from 1805 to 2205 UTC.
WTN 30 NM OF LN /4622N 07925W/ NORTH BAY - / 4458N07918W/ MUSKOKA - /4302N08109W/LONDON. TS MAX TOPS 300 OBSD ON RADAR. LN MOVG EWD AT 20 kt. LTL CHG IN INTSTY.	Thunderstorms have been observed on weather radar within 30 NM of a line from North Bay to Muskoka to London. The maximum tops of the line of thunderstorms is expected to be 30 000 ft. The line is moving in an eastward direction at 20 kt. Little change in intensity is expected in the development of the thunderstorms during the valid period.

3.19 SURFACE WEATHER MAPS

COLOUR	SYMBOL	DESCRIPTION
BLUE	H	High pressure centre
RED	L	Low pressure centre
BLUE		Cold front
BLUE		Cold front aloft
RED		Warm front
RED		Warm front aloft
RED / BLUE		Stationary front
PURPLE		Occluded front
BLUE		Cold frontogenesis
RED		Warm frontogenesis
RED / BLUE		Stationary frontogenesis
BLUE		Cold frontolysis
RED		Warm frontolysis
RED / BLUE		Stationary frontolysis
PURPLE		Occluded frontolysis
PURPLE		Squall Line
PURPLE		Trough
BLUE / RED		Trowal

1. Check the time of the map, make sure that it is the latest one available.
2. Always remember that weather moves. A map gives you a static picture of weather conditions over a large area at a specific time. Always use a map along with the latest reports and forecasts.

3. The curving lines on the map which form patterns like giant thumb-prints are called isobars. Joining points of equal sea level pressure, isobars outline the areas of High and Low pressure, marked H and L, respectively.
4. The winds at 2000 feet AGL blow roughly parallel to the isobars – in a clockwise direction around Highs and counter-clockwise around Lows. Wind speeds vary with the distance between isobars. Where the lines are close together, one can expect moderate to strong winds; where they are far apart, expect light variable winds.
5. The red and blue lines are called Fronts. These lines indicate the zones of contact between large air masses with differing physical properties – cold vs. warm, dry vs. moist, etc. Blue lines are for cold fronts – cold air advancing. Red lines are for warm fronts – warm air advancing. Alternate red and blue lines are for quasistationary fronts – neither warm air nor cold air advancing. Hook marks in red and blue are for trowals-trough of warm air aloft. A purple line is called an Occluded Front – where a cold front has overtaken a warm front. Solid coloured lines are fronts which produce air mass changes at the ground level as well as in the upper air. Dashed coloured lines represent “upper air” fronts – they also are important. Along all active fronts one usually encounters clouds and precipitation.
6. When colours cannot be used to distinguish the various kinds of fronts, monochromatic symbols are used.

3.20 UPPER LEVEL CHARTS – ANAL

Analysed Charts (ANAL)

Meteorological parameters in the upper atmosphere are measured twice a day (0000Z and 1200Z). The data are plotted and analysed on constant pressure level charts. These charts always indicate past conditions. The 850 mb (5 000 feet), 700 mb (10 000 feet), 500 mb (18 000 feet), and 250 mb (34 000 feet) analysed charts are available in Canada and are generally in weather offices about three hours after the data are recorded.

The maps have various fields analysed.

- (a) *Height:* The solid lines (contours) on all the charts represent the approximate height of the pressure level indicated by the map. The contours are labelled in decametres (10's of metres) such that on a 500 mb map, 540 means 5 400 m and on a 250 mb map, 020 means 10 200 m. Contours are spaced 60 m (6 decametres) apart except at 250 mb where the spacing is 120 m.
- (b) *Temperature:* Temperature is analysed on the 850 and 700 mb charts only. Dashed lines are drawn at 5°C intervals and are labelled 5, 0, -5, etc. Temperatures at 500 and 250 mb are obtained by reading the number in the upper left corner of each of the station plots.
- (c) *Wind Direction:* Wind direction may be determined at any point by using the height contours. The wind generally blows parallel to the contours and the direction is determined by keeping the “wind at your back with low heights to the left”. The plotted wind arrows also provide the actual wind direction at the stations.
- (d) *Wind Speed:* Wind speed is inversely proportional to the spacing of the height contours. (If the contours are close together, the winds are strong; if far apart, the winds are light.) The plotted wind arrows also provide the wind speed.

On the 250 mb chart, wind speeds are analysed using dashed lines for points with the same wind speed (isotachs). The isotachs are analysed by a computer and are drawn at 30 KT intervals starting at 30 KT. (NOTE: Computer analysed charts have the analysed parameters SMOOTHED to some extent.)

3.21 VOLCANIC ASH PROGNOSTIC CHARTS

- (a) *Availability and Coverage:* These charts are produced by Environment Canada (EC) only when volcanic ash threatens Canadian domestic airspace or adjacent areas. They are normally available 1 hour after the execution of the Canadian Meteorological Centre (CMC) computer model which generates them. The results are based on the execution of the last global numerical weather prediction model using either 0000 or 1200 UTC data. The areas normally covered are Alaska, Canada, United States, the North Atlantic and Northwest Pacific Oceans.
- (b) *Description:* Each prognostic chart consists of six panels. Each panel depicts the average ash density forecast for an atmospheric layer at a specific time. The layers are surface to FL200, FL200 to FL350, and FL350 to FL600. The first chart depicts a 6 and 12 hour prognostic; the second extends the forecast out to 18 and 24 hours. Additional charts covering a time period of up to 72 hours ahead may sometimes be produced.

The location of the volcano is indicated by the symbol “s”. The average volcanic ash density in the atmospheric layer is depicted as light, moderate or heavy. The isolines are for 10, 100 and 1000 micrograms per cubic metre. The areas between the isolines are enhanced as follows:

10 – 100	Light stippling	(LGT)
100 – 1000	Dark stippling	(MDT)
> 1000	No enhancement	(HVY)

CAUTION: Users are reminded to consult the latest SIGMET for updates on the position and vertical extent of the volcanic ash warning area. Even light (LGT) concentrations constitute a potential danger to aviation. Turbine engine flame-outs have been attributed to light volcanic ash clouds located up to 1 000 NM from the source (see AIR 2.6).



Example of a Forecast of Visual Volcanic Ash Plume

FORECAST OF VISUAL VOLCANIC ASH PLUME
PREVISION DU PANACHE VISIBLE DE CENDRES VOLCANIQUES

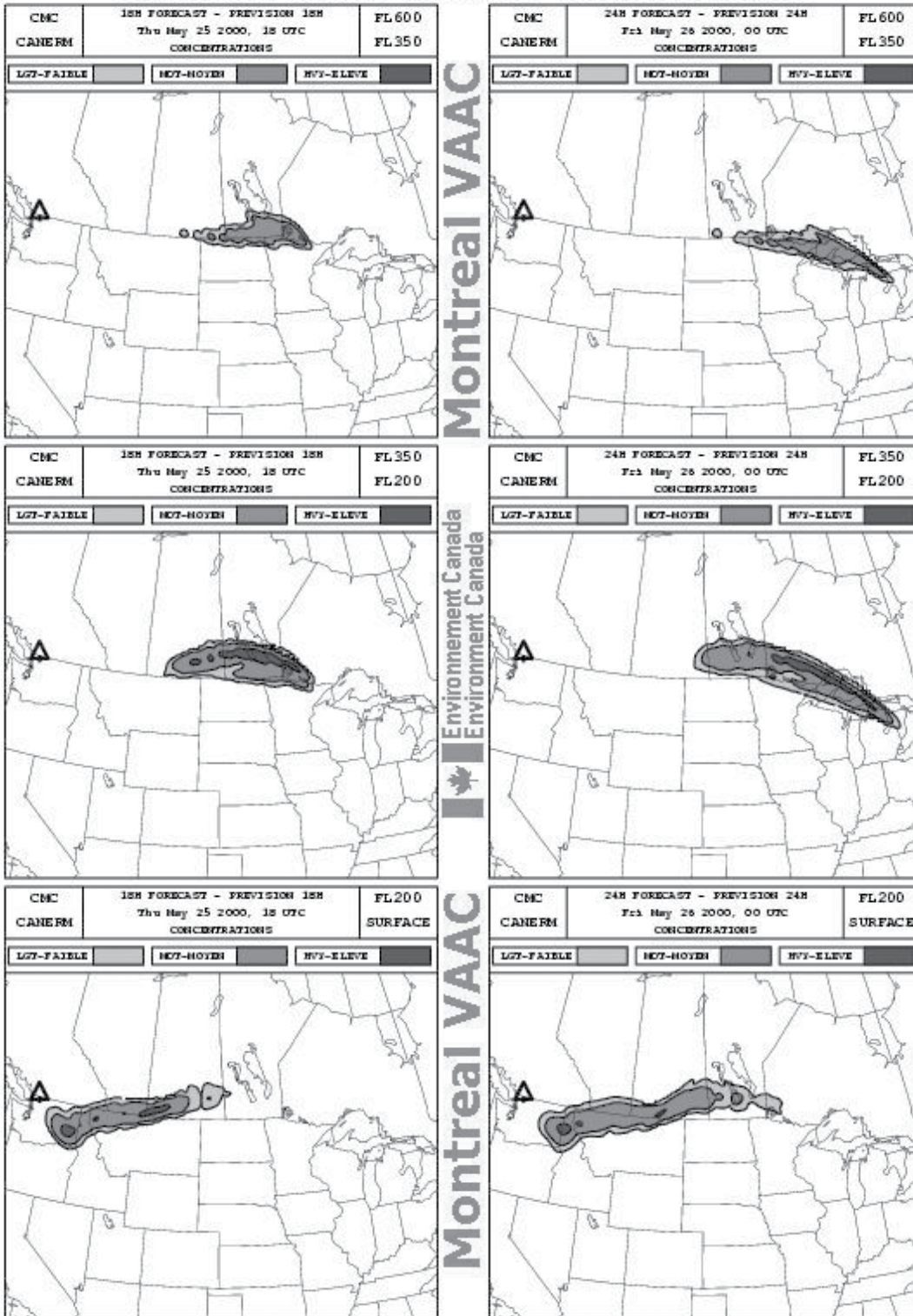

SOURCE : BAKER TEST 48 47' N 121 49' W
 ERUPTION : Thu May 25 2000, 0000Z
 DURATION : 3 Hour(s)
 ASH CLOUD TOP: FL394
 CYCLE : (12.0, 18, TC, VC)

FOR GUIDANCE ONLY NOT AN OFFICIAL FORECAST
 SEE CURRENT SIGMET FOR WARNING AREA

MET

RAC – RULES OF THE AIR AND AIR TRAFFIC SERVICES

1.0 GENERAL INFORMATION

1.1 AIR TRAFFIC SERVICES

The following is a list of control, advisory and information services that are available to pilots.

1.1.1 ATC and Information Services

The following air traffic control and information services are provided by ACCs and TWRs.

- (a) Airport control service is provided by airport TWRs to aircraft and vehicles on the manoeuvring area of an airport and to aircraft operating in the vicinity of an airport.
- (b) Area control service is provided by ACCs to IFR and CVFR flights operating within specified control areas.
- (c) Terminal control service is provided by ACCs to IFR and CVFR flights operating within specified control areas.
- (d) Terminal radar service is an additional service provided by IFR units to VFR aircraft operating within Class C airspace.
- (e) Alerting service notifies appropriate organizations regarding aircraft in need of search and rescue services, or alerts crash equipment, ambulances, doctors and any other safety services.
- (f) Altitude reservation service includes the service of the altitude reservation East (Gander) and altitude reservation West (Edmonton) in co-ordination with ACCs in providing reserved altitude for specified air operations in controlled airspace, and in providing information concerning these reservations and military activity areas in controlled and uncontrolled airspace.
- (g) AMIS is provided by ACCs for the collection, processing and dissemination of aircraft movement information for use by air defence units relative to flights operating into or within Canadian ADIZ.
- (h) Flight information service is provided by ATC units to assist pilots by supplying information concerning known hazardous flight conditions. This information will include data concerning unfavourable flight conditions and other known hazards; which may not have been available to the pilot prior to takeoff or which may have developed along the route of flight.

The ATC service has been established primarily for the prevention of collisions and the expediting of traffic. The provision of such service will take precedence over the provision of flight information service, but every effort will be made to provide flight information and assistance.

Flight information will be made available, whenever practicable, to any aircraft in communication with an ATC unit, prior to takeoff or when in flight, except where such service is provided by the aircraft operator. Many factors (such as volume of traffic, controller workload, communications frequency congestion and limitations of radar equipment) may prevent a controller from providing this service.

VFR flights will be provided with information concerning:

- (a) severe weather conditions along the proposed route of flight;
- (b) changes in the serviceability of navigation aids;
- (c) conditions of airports and associated facilities;
- (d) other items considered pertinent to safety of flight.

IFR flights will be provided with information concerning:

- (a) severe weather conditions;
- (b) weather conditions reported or forecast at destination or alternate aerodromes;
- (c) changes in the serviceability of navigation aids;
- (d) condition of airports and associated facilities; and
- (e) other items considered pertinent to the safety of flight.

Flight information messages are intended as information only. If a specific action is suggested, the message will be prefixed by the term “ATC SUGGESTS...” or “SUGGEST YOU...” and the pilot will be informed of the purpose of the suggested action. The pilot is responsible for making the final decision concerning any suggestion.

Surveillance radar equipment is frequently used in the provision of information concerning hazards, such as chaff drops, bird activity and possible traffic conflicts. Due to limitations inherent in all radar systems, aircraft, chaff, etc., cannot be detected in all cases.

RAC

Whenever practicable, ATC will provide flights with severe weather information pertinent to the area concerned. Pilots may assist ATC by providing pilot reports of severe weather conditions they encounter. ATC will endeavour to suggest alternate routes available in order to avoid areas experiencing severe weather.

ATC will provide pilots intending to operate through chaff areas with all available information relating to proposed or actual chaff drops:

- (a) location of chaff drop area;
- (b) time of drop;
- (c) estimated speed and direction of drift;
- (d) altitudes likely to be affected; and
- (e) relative intensity of chaff.

Information concerning bird activity, obtained through controller's observations or pilot reports, will be provided to aircraft operating in the area concerned. In addition, pilots may be warned of possible bird hazards if radar observation indicates the possibility of bird activity. Information will be provided concerning:

- (a) size or species of bird, if known;
- (b) location;
- (c) direction of flight; and
- (d) altitude, if known.

Radar traffic information and radar navigation assistance to VFR flights are contained in RAC 1.5.

1.1.2 Flight Advisory and Information Services

The following flight advisory and information services are provided by FICs and FSSs.

1.1.2.1 A FIC provides:

- (a) *Pilot briefing service*: the provision of, or consultation on, meteorological and aeronautical information to assist pilots in pre-flight planning for the safe and efficient conduct of flight. The flight service specialist adapts meteorological information, including satellite and radar imagery, to fit the needs of flight crew members and operations personnel, and provides consultation and advice on special weather problems. Flight service specialists accept flight plan information during a briefing (see RAC 3.2 for details).

- (b) *FISE*: the exchange on the FISE frequency of information pertinent to the en-route phase of flight. Air traffic information is not provided. Upon request from an aircraft, a FIC provides:
 - (i) meteorological information: SIGMET, AIRMET, PIREP, aviation routine weather report (METAR), aviation selected special weather report (SPECI), aerodrome forecast (TAF), altimeter setting, weather radar, lightning information and briefing update;
 - (ii) aeronautical information: NOTAM, RSC, CRFI, MANOT and other information of interest for flight safety; and
 - (iii) relay of communications with ATC: IFR clearance and SVFR authorization.

En-route aircraft may submit to a FIC: PIREPs, IFR and VFR position reports (including arrival and departure times), revised flight plan or flight itinerary information and other reports, such as vital intelligence sightings (CIRVIS), fireball (meteorite) observations or pollution reports (see RAC 1.12 for details on pilot reports). Fuel dumping information may also be submitted for coordination with the appropriate ACC and for aeronautical broadcast needs (see RAC 6.3.4 for details).

- (c) *Aeronautical broadcast service*: the broadcast on the FISE frequency, and on 126.7 MHz, of SIGMET, urgent PIREP and information concerning fuel dumping operations.
- (d) *VFR flight plan alerting service*: the notification of RCCs and provision of communications searches when an aircraft on a VFR flight plan or flight itinerary becomes overdue and needs SAR aid.
- (e) *Flight regularity message service*: the relay by FICs of messages between an aircraft in flight and the aircraft operating agency, and vice versa, when an agency with AFTN access subscribes to the service for an annual cost. Agencies interested in subscribing to this service should contact the NAV CANADA Customer Service Centre.

1.1.2.2 An FSS provides:

- (a) *AAS*: the provision of information pertinent to the arrival and departure phases of flight at uncontrolled aerodromes and for transit through an MF area. AAS is provided on the MF and is normally in conjunction with VCS.

The elements of information listed below are provided, if appropriate, by the flight service specialist during initial aerodrome advisory communications with an aircraft:

- (i) active or preferred runway (see *Glossary of Aeronautical Terms*, GEN 5.1);
- (ii) wind direction and speed;
- (iii) air traffic that warrants attention;
- (iv) vehicle traffic;
- (v) wake turbulence cautionary;
- (vi) aerodrome conditions;
- (vii) weather conditions; and
- (viii) additional information of interest for the safety of flight.

The flight service specialist updates this information, when appropriate, after the initial advisory. Pilots are encouraged to indicate in initial transmissions to the FSS that information has been obtained from the ATIS or from an AWOS (or LWIS) broadcast, or use the phrase “HAVE NUMBERS” if runway, wind and altimeter information from the previous aerodrome advisory have been received, so that the flight service specialist does not repeat the information.

Mandatory reports by aircraft on the MF are critical for the FSS to be able to provide effective air traffic information. At certain FSS locations, air traffic information may also be based on radar display (see RAC 1.5.8 for details on the use of radar by an FSS). A pilot remains responsible for avoidance of traffic in Class E airspace.

Communications regarding TCAS events and displayed information should be limited to that required to inform the flight service specialist that the aircraft is responding to an RA. Discretion should be used in using the TCAS traffic display to ask questions regarding traffic in the vicinity of an aircraft. As would be expected, aircraft shown on a TCAS display may not match the traffic information provided by the flight service specialist.

NOTAM, RSC and CRFI are included in advisories for a period of 12 hr for domestic traffic, and 24 hr for international traffic, after dissemination by means of telecommunication. Aerodrome conditions published prior to these time limits should have been received in the pilot briefing or can be obtained on request.

Aerodrome lighting is operated by the FSS, unless otherwise indicated in the CFS. The flight service specialist relays ATC clearances, SVFR authorizations, and routinely informs the ACC of all IFR arrival times. The specialist also relays a VFR arrival report to a FIC upon request from an aircraft.

Pilots should be aware that a flight service specialist will alert the appropriate agencies for any aircraft that has received a landing advisory for an aerodrome that lies within an MF area and within radio communication range, if it fails to arrive within 5 min of its latest ETA, and communication cannot be re-established with the aircraft.

(b) *VCS*: the provision, at locations where AAS is provided, of instructions to control the movements of vehicles, equipment and pedestrians on manoeuvring areas of uncontrolled aerodromes. Flight service specialists will normally instruct vehicle traffic to leave the intended runway at least 5 min prior to the estimated time of landing or before a departing aircraft enters the manoeuvring area. The specialist will coordinate with the pilot prior to authorizing traffic to operate on the intended runway within less than 5 min of the estimated time of landing or the time an aircraft is ready for takeoff.

(c) *VDF service*: the provision of VDF navigation assistance to VFR aircraft. This service includes provision of the aircraft’s bearing and a reciprocal heading, but is not intended as a substitute for normal VFR navigation (see RAC 1.6 for details).

1.1.2.3 FICs and FSSs may provide:

(a) *RAAS*: the provision, via RCO, of information pertinent to the arrival and departure phases of flight and for transit through an MF area.

RAAS consists in the issuance of the same type of information as in AAS, except that it is provided from a remote location. It is emphasized that the flight service specialist cannot observe the runways, taxiways, airspace or weather conditions in the vicinity of the aerodrome. Wind, altimeter and other weather information is usually extracted from the latest METAR or SPECI, and may not always be as representative of actual conditions as in AAS.

(b) *VAS*: the provision, via RCO, of information and advisories concerning the movements of vehicles, equipment and pedestrians on manoeuvring areas at designated uncontrolled aerodromes. VAS is provided at locations where RAAS is also provided. The flight service specialist will request vehicle traffic to leave the intended runway at least 5 min prior to the estimated time of landing, but cannot ascertain visually if the traffic has actually vacated the runway.

(c) *Alerting service*: the notification of appropriate organizations regarding aircraft in need of SAR services or alerts of crash equipment, ambulances, doctors and any other safety services. Alerting of a responsible authority, if experiencing unlawful interference (hijack), bomb threat or inability to communicate in the clear, is also included in this service.

(d) *Emergency assistance service*: the provision of aid to a pilot when in an emergency, or potential emergency situation, such as being lost, encountering adverse weather conditions or experiencing aircraft-related emergencies or equipment failure. At some locations, emergency navigational assistance is provided to a pilot who is lost or experiencing IMC, through the use of VDF equipment or by transferring the pilot to ATC for radar service (see RAC 1.6 for VDF service).

(e) *NOTAM information service*: the collection and dissemination of NOTAM, RSC and CRFI information by the flight service specialist. A pilot may report to a FIC or an FSS any hazards to the air navigation system that may need NOTAM distribution. The flight service specialist will distribute the information if it meets the criteria established in the *Canadian NOTAM Procedures Manual*.

- (f) *Weather observation service*: the observation, recording and dissemination of surface weather information for aviation purposes.

1.1.2.4 International Flight Service Station (IFSS)

An aeronautical station that provides a communications service for international air operators. Gander is the only IFSS in Canada.

1.1.3 RCOs and DRCOs

- (a) RCOs are VHF transmitters/receivers installed at designated aerodromes to permit communications between aircraft and an FSS or FIC for the provision of FISE or RAAS. An RCO may also be installed at an off-aerodrome location to enhance en-route communication coverage for the provision of FISE by FICs.

The RCO system is being redesigned. Currently, in most areas of the country, these services are provided on one frequency, i.e. 126.7 MHz. In the final system configuration, FISE RCOs will use one of the following four frequencies: 123.275, 123.375, 123.475, or 123.55 MHz. At most RCO sites where one of these four FISE frequencies is used, 126.7 MHz will be retained but will not be active or monitored by a FIC. At these sites, as required, the FIC activates and transmits on 126.7 MHz to provide aeronautical broadcast service (broadcast of SIGMET or urgent PIREP) and to conduct communication searches for overdue aircraft. When the FIC transmits on 126.7 MHz, the FISE frequency is also automatically activated so that broadcasts occur simultaneously on the FISE frequency and on 126.7 MHz. RCOs with 126.7 MHz operated in this manner are published as 126.7 (bcst).

At certain isolated RCO sites, 126.7 MHz is the frequency used to provide all the required services (FISE, aeronautical broadcast service and to conduct communication searches for overdue aircraft). In these circumstances, it is continuously monitored by a FIC, and is published in the CFS as 126.7 (FISE) and on charts/maps as 126.7.

- (b) A DRCO is a standard RCO that has had a dial-up unit installed to connect the pilot with an ATS unit (e.g. FIC) via a commercial telephone line. In this manner, the line is only “opened” after the communication has been initiated by the pilot or ATS. The radio range of the RCO is unaffected by the conversion.

Activation of the system by the pilot is accomplished via the aircraft radio transmitter, and is effected by keying the microphone button four times with a deliberate and constant action on the published DRCO frequency. The microphone push-to-talk button should be held down for a fraction of a second ($\frac{1}{4}$ of a second, to be technically correct) for each keying action with no more than 1 second between each action. The entire process should take slightly less than 10 seconds.

The remote dial unit is designed to accept this constant and deliberate action so as to reduce the possibility of inadvertent activation from other sources. Consequently, if a microphone is keyed more than four times, or too rapidly (or too slowly), the system will not activate.

Once the communication link has been established, the DRCO equipment will answer the pilot with a pre-recorded voice message: “link established.” The link can only be actively disconnected by the ATS unit.

- (i) Activation of the DRCO—Pilot Procedures
- (A) Select the published RCO frequency on the aircraft radio transceiver.
 - (B) Key the radio microphone distinctly four times in a row, with no more than 1 second between each keying. If the keying procedure is successful, the pilot will hear a dial tone, signalling pulses (e.g. touch tones), and finally a ringing signal (see **NOTE**).
If the keying procedure has been successful, but the line is not available, the equipment will automatically disconnect, and the message, “try again” will be broadcast.
 - (C) Wait for the DRCO equipment to answer with the pre-recorded voice message, “link established.” This reply confirms that the phone link with ATS has been established. The pilot must now initiate the radio conversation as per standard radiotelephony practices, e.g. “Quebec Radio, this is CESSNA GOLF ALFA DELTA TANGO, over.” It is important to note that the ATS specialist may be performing other duties (e.g. working on another frequency or taking a weather observation) and may not be able to acknowledge the pilot’s radio call right away.
 - (D) The RCO line can only be actively disconnected by the ATS unit.
 - (E) A “call terminated” message indicates that the telephone line has been inadvertently disconnected.

NOTE: If the dial tone, signalling, and ringing are not heard, the pilot can assume that either:

- (a) the RCO is not within the radio range of the aircraft’s transceiver; or
- (b) the RCO line has already been opened, and there is a pause in the communication between the pilot of another aircraft and the ATS unit.

The pilot may assume that the line is open and attempt to initiate communications with ATS. If no reply is received from ATS within a reasonable time interval, the pilot should reattempt the keying procedure when in closer proximity to the RCO site.

1.1.4 Arctic Radio

Arctic Radio operates from the North Bay FIC (Ontario). It provides FISE and emergency communication to aircraft operating in the Northwest Territories and Nunavut and in the vicinity of the ADIZ. It also provides radar position information (latitude and longitude, bearing and distance, altitude and ground speed) upon pilot request.

1.1.5 Military Flight Advisory Unit

DND operates Military Flight Advisory Unit (MFAU) which provide flight information services that enhance flight safety and efficiency. These services are available by calling the appropriate station followed by “Advisory”, i.e., “Namao Advisory”. MFAU provide en route flight information, airport advisory, ground control, field condition reports, flight planning, alerting service, navigation assistance, NOTAM, PIREPs, and weather reports. An MFAU may be used to accept and relay VFR and IFR position reports and ATC clearances.

1.2 SERVICES OTHER THAN AIR TRAFFIC SERVICES

1.2.1 Universal Communications

Universal Communications (UNICOM) is an air-to-ground communications facility operated by a private agency to provide Private Advisory Station (PAS) service at uncontrolled aerodromes. At these locations the choice of frequencies are 122.7, 122.8, 123.0, 123.3, 123.5, 122.75, 122.95, 123.35, 122.725, 122.775 and 122.825 MHz.

The use of all information received from a UNICOM station is entirely at the discretion of the pilot. The frequencies are published in aeronautical information publications as a service to pilots, but Transport Canada takes no responsibility for the use made of a UNICOM frequency.

An approach UNICOM (AU) is an air-ground communications service that can provide approach and landing information to IFR pilots. The service provider is required to ensure that

- (a) meteorological instruments used to provide the approach and landing information meet the requirements stipulated under CAR 804.01(c) or the applicable exemption; and
- (b) UNICOM operators meet the training requirements stipulated under CAR 804.01(c) or the applicable exemption.

Where the above standards are met, the AU operator may provide a station altimeter setting for the conduct of an instrument procedure as well as the wind speed and direction for the conduct of a straight-in landing from an instrument approach.

Operators providing AU services may also advise pilots of the runway condition and the position of vehicles or aircraft on the manoeuvring area. Regulations and standards regarding the provision of these services from an AU are under development.

An AU will be indicated as “UNICOM” (AU) *in the Canada Air Pilot and the Canada Flight Supplement*.

1.2.2 Airport Radio/Community Aerodrome Radio Station

Airport radio (APRT RDO), in most cases, is provided by a community aerodrome radio station (CARS) and has been established to provide aviation weather and communication services to enhance aircraft access to certain aerodromes.

APRT RDO/CARS service is provided by observer-communicators (O/C) who are certified to conduct aviation weather observations and radio communications to facilitate aircraft arrivals and departures.

Hours of operation are listed *in the Canada Flight Supplement (CFS) Aerodrome/ Facility Directory* under the subheadings COM/APRT RDO.

Services provided by APRT RDO/CARS include the following:

- (a) *Emergency Service*: The O/C will respond to all emergency calls (distress, urgency and ELT signals), incidents or accidents by alerting a designated NAV CANADA FIC and appropriate local authorities.
- (b) *Communication Service*: The O/C will provide pilots with information in support of aircraft arrivals and departures, including wind, altimeter, runway and aerodrome status (including vehicle intentions and runway condition), current weather conditions, PIREPs and known aircraft traffic.

NOTES 1: O/Cs are authorized to provide an altimeter setting for an instrument approach.

2: O/Cs provide limited traffic information. APRT RDOs/CARS are located at uncontrolled aerodromes within MF areas. Pilots must communicate on the MF as per uncontrolled aerodrome procedures (see RAC 4.5.1 to 4.5.7, RAC 9.12, 9.13 and 9.14).

3: O/Cs do not provide ATC services. At aerodromes within controlled airspace served by APRT RDO/ CARS, pilots must contact ATS via the RCO, PAL or telephone to obtain special VFR authorization or IFR clearances.

(c) *Weather Observation Service*: The O/C will monitor, observe, record and relay surface weather data for aviation purposes (METARs or SPECIs) in accordance with CAR 804 standards. The O/C may request PIREPs from pilots to confirm weather conditions, such as height of cloud bases.

(d) *Flight Plan/Flight Information Service*: If necessary, at most APRT RDOs/CARS, O/Cs will accept flight plans/itineraries; however, pilots are encouraged to obtain a full pre-flight briefing and then file their flight plan/itinerary with a FIC.

NOTE: Pilots should be aware that O/Cs are only authorized to provide NOTAMs and weather information (METARs or SPECIs) for their own aerodrome. Information for other areas/aerodromes should be obtained from an FIC.

At APRT RDO/CARS sites colocated with an RCO, pilots should open and close flight plans/itineraries, pass position reports and obtain FISE directly from the FIC via the RCO. At sites with no RCO, when requested by the pilot, the APRT RDO/CARS O/C will relay messages to open and close flight plans/itineraries and position reports (IFR, VFR, DVFR) to a FIC.

(e) *Monitoring of Equipment/NAVAIDs*: During the APRT RDO/CARS hours of operation, O/Cs will monitor the status of equipment related to aerodrome lighting, weather, communications, etc. Malfunctions will be reported to the designated NAV CANADA facility, and a NOTAM will be issued as required. For site-specific NAVAID monitoring by APRT RDO/CARS, refer to the CFS and Enroute Low Altitude and Enroute High Altitude charts.

1.2.3 Private Advisory Stations (PAS)— Controlled Airports

Aeronautical operators may establish their own private facilities at controlled airports for use in connection with company business, such as servicing of aircraft, availability of fuel, and lodging. The use of PAS at controlled aerodromes shall not include information relative to ATC, weather reports, condition of landing strips, or any other communication normally provided by ATC units.

1.2.4 Apron Advisory Service

Apron advisory service at most controlled airports is provided by ATS. However, some large airports are providing advisory service on aprons through a separate apron management unit staffed by airport or terminal operator personnel. This service normally includes gate assignment, push-back instructions, and advisories on other aircraft and vehicles on the apron. Aircraft entering the apron will normally be instructed by the ground controller to contact apron prior to or at the designated change-over point. Aircraft leaving the apron shall contact ground on the appropriate frequency to obtain taxi clearance before exiting the apron and before entering the manoeuvring area.

1.3 ATIS

ATIS is the continuous broadcasting of recorded information for arriving and departing aircraft on a discrete VHF/UHF frequency. Its purpose is to improve controller and flight service specialist effectiveness and to relieve frequency congestion by automating the repetitive transmission of essential but routine information.

ATIS messages are recorded in a standard format and contain such information as:

- (a) airport name and message code letter;
- (b) weather information, including:
 - (i) time,
 - (ii) surface wind, including gusts,
 - (iii) visibility,
 - (iv) weather and obstructions to vision,
 - (v) ceiling,
 - (vi) sky condition,
 - (vii) temperature,
 - (viii) dew point,
 - (ix) altimeter setting,
 - (x) pertinent SIGMETs, AIRMETs and PIREPs, and
 - (xi) other pertinent remarks;
- (c) type of instrument approach in use, including information on parallel or simultaneous converging runway operations;
- (d) landing runway, both IFR and VFR, including information on hold short operations and the stopping distance available;
- (e) departure runway, both IFR and VFR;
- (f) a NOTAM or an excerpt from a NOTAM, pertinent information regarding the serviceability of a NAVAID, or field conditions applicable to arriving or departing aircraft. These may be deleted from an ATIS message after a broadcast period of 12 hr at domestic airports or 24 hr at international airports;
- (g) instruction that aircraft are to acknowledge receipt of the ATIS broadcast on initial contact with ATC/FSS.

Each recording will be identified by a phonetic alphabet code letter, beginning with ALFA. Succeeding letters will be used for each subsequent message.

Example of an ATIS Message:

TORONTO INTERNATIONAL INFORMATION BRAVO. WEATHER AT ONE FOUR ZERO ZERO ZULU: WIND ZERO FIVE ZERO AT TWO ZERO, VISIBILITY FIVE HAZE, CEILING THREE THOUSAND OVERCAST, TEMPERATURE ONE EIGHT, DEW POINT ONE SIX, ALTIMETER TWO NINER FOUR SIX, PARALLEL ILS APPROACHES ARE IN PROGRESS. IFR LANDING ZERO SIX RIGHT, ZERO SIX LEFT. VFR LANDING ZERO SIX LEFT. DEPARTURE ZERO SIX LEFT. NOTAM: GLIDE PATH ILS RUNWAY ONE FIVE OUT OF SERVICE. INFORM ATC YOU HAVE INFORMATION BRAVO.

NOTE: Current time and RVR measurements will not be included in the ATIS message, but will be issued in accordance with current practices. Temperature and dew point information is derived only from the scheduled hourly weather observations.

Pilots hearing the broadcast should inform the ATC/FSS unit on initial contact that they have received the information, by repeating the code letter that identifies the message, thus obviating the need for the controller/specialist to issue information.

Example: ...*WITH BRAVO*.

During periods of rapidly changing conditions that would create difficulties in keeping the ATIS message current, the following message will be recorded and broadcasted:

BECAUSE OF RAPIDLY CHANGING WEATHER/AIRPORT CONDITIONS, CONTACT ATC/FSS FOR CURRENT INFORMATION.

The success and effectiveness of ATIS is largely dependent upon the co-operation and participation of airspace users; therefore, pilots are strongly urged to take full advantage of this service.

1.4 USE OF TERM "CAVOK"

The term "CAVOK" (KAV-OH-KAY) may be used in air-to-ground communications when transmitting meteorological information to arriving aircraft.

CAVOK refers to the simultaneous occurrence of the following meteorological conditions at an airport:

- (a) no cloud below 5 000 feet, or below the highest minimum sector altitude, whichever is higher, and no cumulonimbus;
- (b) a visibility of 6 SM or more;
- (c) no precipitation, thunderstorms, shallow fog, or low drifting snow.

This term, coupled with other elements of meteorological information, such as wind direction and speed, altimeter setting and pertinent remarks, will be used in transmissions directed to arriving aircraft and, where applicable, in the composition of ATIS messages. A pilot, on receipt of CAVOK, may request that detailed information be provided.

CAVOK does not apply to the provision of meteorological information to en route aircraft and, therefore, will not be used when such information is transmitted to aircraft engaged in that particular phase of flight.

1.5 RADAR SERVICE

1.5.1 General

The use of radar increases airspace utilization by allowing ATC to reduce the separation interval between aircraft. In addition, radar permits an expansion of flight information services, such as traffic information, radar navigation assistance and information on chaff drops and bird activity. Due to limitations inherent in all radar systems, it may not always be possible to detect aircraft, weather disturbances, etc. Where radar information is derived from secondary surveillance radar (SSR) only (i.e., without associated primary radar coverage), it is not possible to provide traffic information on aircraft that are not transponder-equipped or to provide some of the other flight information. Radar systems are described in COM 3.13.

1.5.2 Procedures

Before providing radar service, ATC will establish identification of the aircraft concerned either through the use of position reports, identifying turns, or transponders. Pilots will be notified whenever radar identification is established or lost.

Examples:

IDENTIFIED; or IDENTIFICATION LOST.

Pilots are cautioned that radar identification of their flight does not relieve them of the responsibility for collision avoidance or terrain (obstacle) clearance. ATC will normally provide radar-identified IFR and CVFR flights with information on observed radar targets. At locations where an SSR is used without collocated primary radar equipment, ATC cannot provide traffic information on aircraft without a functioning transponder.

ATC assumes responsibility for terrain (obstacle) clearance when vectoring en route IFR and CVFR flights and for IFR aircraft being vectored for arrival until the aircraft resumes normal navigation.

Vectors are used when necessary for separation purposes, when required by noise abatement procedures, when requested by the pilot, or whenever vectors will offer operational advantages to the pilot or the controller. When vectors are initiated, the pilot will be informed of the location to which the aircraft is being vectored.

Example:

VECTORS TO VICTOR THREE ZERO ZERO, TURN LEFT HEADING ZERO FIVE ZERO. VECTORS TO THE VANCOUVER V-O-R ZERO FIVE THREE RADIAL, FLY HEADING ZERO TWO ZERO. VECTORS TO FINAL APPROACH COURSE, DEPART KLEINBURG BEACON ON HEADING TWO FOUR ZERO.

Pilots will be informed when vectors are terminated, except when an arriving aircraft is vectored to the final approach course or to the traffic circuit.

Example: RESUME NORMAL NAVIGATION.

When an aircraft is vectored to final approach or to the traffic circuit, the issuance of approach clearance indicates that normal navigation should be resumed.

Normally radar service will be continued until an aircraft leaves the area of radar coverage, enters uncontrolled airspace, or is transferred to an ATC unit not equipped with radar. When radar service is terminated the pilot will be informed accordingly.

Example: RADAR SERVICE TERMINATED.

1.5.3 Radar Traffic Information

Traffic (or workload) permitting, ATC will provide IFR and CVFR flights with information on observed radar targets whenever the traffic is likely to be of concern to the pilot, unless the pilot states that the information is not wanted. This information may be provided to VFR aircraft when requested by the pilot.

If requested by the pilot, ATC will attempt to provide radar separation between identified IFR aircraft and the unknown observed aircraft.

When issuing radar information, ATS units will frequently define the relative location of the traffic, weather areas, etc., by referring to the clock position. In this system, the 12 o'clock position is based on the observed radar track rather than the actual nose of the aircraft. In conditions of strong crosswind, this can lead to a discrepancy between the position as reported by the controller and the position as observed by the pilot.

The following diagram illustrates the clock positions.

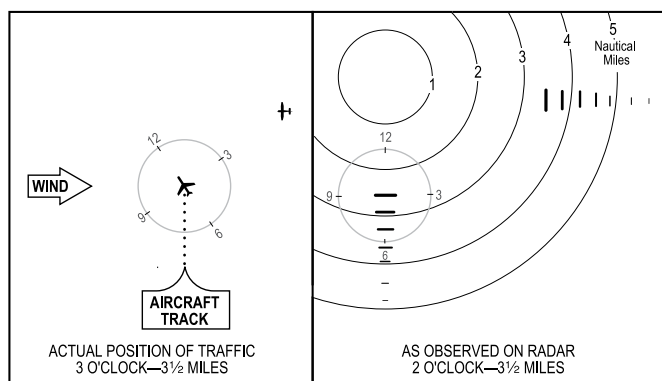

Issue traffic information to radar-identified aircraft as follows:

1. Position of the traffic in relation to the aircraft's observed track.
2. Direction of flight.
3. Type of aircraft, if known, or the relative speed and the altitude, if known.

NOTE: Direction of flight may be expressed as OPPOSITE DIRECTION or SAME DIRECTION, while the altitude may be expressed as a number of feet above or below the aircraft receiving the traffic information.

Example:

TRAFFIC, TWO O'CLOCK, THREE AND A HALF MILES, WESTBOUND, B747, ONE THOUSAND FEET ABOVE YOUR ALTITUDE.

Issue traffic information to non-radar-identified aircraft as follows:

1. Position of the traffic in relation to a fix.
2. Direction of flight.
3. Type of aircraft, if known, or the relative speed and the altitude, if known.

NOTE: Direction of flight may be expressed as OPPOSITE DIRECTION or SAME DIRECTION, while the altitude may be expressed as a number of feet above or below the aircraft receiving the traffic information.

Example:

TRAFFIC, SEVEN MILES SOUTH OF RESOLUTE BAY VOR, NORTHBOUND, B737, FL300.

1.5.4 Radar Navigation Assistance to VFR Flights

When requested by pilots, radar-equipped ATC units will provide assistance to navigation in the form of position information, vectors or track, and ground speed checks. Flights requesting this assistance must be operating within areas of radar and communication coverage, and be radar-identified.

VFR flights may be provided with this service:

- (a) at the request of a pilot, when traffic conditions permit;
- (b) when the controller suggests and the pilot agrees; or
- (c) in the interest of flight safety.

The pilot is responsible for avoiding other traffic and avoiding weather below VFR minima while on a VFR flight on radar vectors.

If a radar vector will lead a VFR flight into IFR weather conditions, the pilot must inform the controller and take the following action:

- (a) if practicable, obtain a vector which will allow the flight to remain in VFR weather conditions; or
- (b) if an alternative vector is not practicable, revert to navigation without radar assistance; or
- (c) if the pilot has an IFR rating and the aircraft is equipped for IFR flight, the pilot may file an IFR flight plan, and request an IFR clearance.

Emergency radar assistance will be given to VFR flights which are able to maintain two-way radio communication with the unit, are within radar coverage, and can be radar identified.

Pilots requiring radar assistance during emergency conditions should contact the nearest ATC unit and provide the following information:

1. Declaration of emergency (state nature of difficulty and type of assistance required).
2. Position of aircraft and weather conditions within which the flight is operating.
3. Type of aircraft, altitude, and whether equipped for IFR flight.
4. Whether pilot has an IFR Rating.

Pilots unable to contact radar but in need of emergency assistance may alert radar by flying a triangular pattern (see SAR 4.5).

1.5.5 Obstacle Clearance During Radar Vectors

(a) IFR Flights

The pilot of an IFR flight is responsible for ensuring that the aircraft is operated with adequate clearance from obstacles and terrain; however, when the flight is being radar-vectorred, ATC will ensure that the appropriate obstacle clearance is provided.

Minimum radar vectoring altitudes (lowest altitude at which an aircraft may be vectored and still meet obstruction clearance criteria), which may be lower than minimum altitudes shown on navigation and approach charts, have been established at a number of locations to facilitate transitions to instrument approach aids. When an IFR flight is cleared to descend to the lower altitude, ATC will provide terrain and obstacle clearance until the aircraft is in a position from which an approved instrument approach or a visual approach can be commenced.

If a communication failure occurs while a flight is being vectored at an altitude below the minimum IFR altitudes shown in the instrument approach chart, the pilot should climb immediately to the appropriate published minimum altitude, unless the flight is able to continue in Visual Meteorological Conditions (VMC).

(b) VFR Flights

The pilot of a VFR aircraft remains responsible for maintaining adequate clearance from obstacles and terrain when the flight is being radar-vectorred by ATC.

If adequate obstacle or terrain clearance cannot be maintained on a vector, the pilot must inform the controller and take the following action:

- (i) if practicable, obtain a heading that will enable adequate clearance to be maintained, or climb to a suitable altitude, or
- (ii) revert to navigation without radar assistance.

1.5.6 Misuse of Radar Vectors

Pilots have, on occasion, for practice purposes, followed radar instructions issued to other pilots without realizing the potential hazard that accompanies such action.

ATC may require aircraft to make turns for radar identification; however, when more than one aircraft target is observed making a turn, identification becomes difficult or impossible. Should misidentification be the result of more than one aircraft following the instructions issued by ATC, it could be hazardous to the aircraft involved.

Any pilot wishing to obtain radar practice, however, needs only to contact the appropriate ACC or TCU and request practice radar vectors. Practice vectors will be issued to the extent that air traffic conditions permit.

1.5.7 Canadian Forces Radar Assistance

The Canadian Forces can provide assistance in an emergency to civil aircraft operating within the ADIZ.

No responsibility for the direct control of aircraft is accepted and radar assistance does not absolve the captain of the responsibility of complying with ATC clearances or other required procedures. Assistance consists of:

- (a) track and ground speed checks—speeds in kt;
- (b) position of the aircraft in geographic reference, or by bearing and distance from the station—distances are in NM and bearings in degrees True; and
- (c) position of heavy cloud in relation to the aircraft.

To obtain assistance in the NWS area, call “Radar Assistance” on 126.7 MHz; or when circumstances require a MAYDAY call, use 121.5 MHz, giving all the necessary details. When assistance is required in ADIZ areas contact will have to be made on the 121.5 MHz frequency or on the UHF frequencies 243.0 or 364.2 MHz. Initial contact should be made at the highest practicable altitude. If air defence commitments preclude the granting of radar assistance, the ground station will transmit the word “UNABLE” and no further explanation will be given.

1.5.8 THE USE OF RADAR IN THE PROVISION OF AAS AND RAAS BY FSSs

Certain FSSs are equipped with a radar display to aid the flight service specialist in monitoring the aircraft traffic situation and to enhance the accuracy of traffic information provided in AAS or RAAS.

An FSS equipped with a radar display:

- (a) may instruct an aircraft to “SQUAWK IDENT” or assign a specific SSR code to the aircraft;
- (b) will acknowledge the squawk transmission or SSR code change by stating the phrase “ROGER IDENT”;
- (c) will issue the reminder “NO CONTROL SERVICE AVAILABLE, THIS IS AN ADVISORY SERVICE,” if deemed appropriate;
- (d) may issue radar-observed traffic information with reference to the 12-hr clock position or geographical locations.

It is important for pilots to keep in mind that:

- (a) flight service specialists may stop monitoring the radar display at any time without prior notice to aircraft;
- (b) FSSs do not inform aircraft when radar identification is lost;
- (c) FSSs do not provide control services such as vectors and conflict resolution;
- (d) pilots are responsible for maintaining a visual lookout outside the cockpit at all times for the purpose of avoiding a collision with other aircraft, terrain and obstacles.

1.6 VDF SERVICE

VDF equipment is available at selected airports across Canada (see COM 3.10).

1.6.1 Purpose

The purpose of the VDF is to provide navigation assistance to VFR aircraft. This equipment is not intended as a substitute for normal VFR navigation, but rather as an aid in times of difficulty.

A VFR aircraft encountering IMC is not normally given VDF headings; rather, on request, it is provided with position information relevant to the VDF site or some other location. However, should a VFR aircraft encountering IMC declare an emergency, navigation assistance to the VDF site will be provided, if appropriate.

1.6.2 Equipment Operation

VDF information is electronically derived from radio signals transmitted from the aircraft. Since VHF transmissions are restricted to line-of-sight, the altitude and location of the aircraft may limit the provision of the service. As in radio communication, the power of the transmitted signal will affect reception distance. Information may be obtained from either a modulated signal (speech transmission) or an un-modulated signal (microphone button pressed—no speech). The length of the transmission is not critical since information can be obtained from a very short transmission (2 s).

1.6.3 Provision of Service

VDF navigation assistance is provided when requested by the pilot or when suggested by the VDF operator (either an airport controller or a flight service specialist) and accepted by the pilot. VDF navigation.

The VDF operator will provide the pilot with heading and bearing information relevant to the VDF site. Pilots planning to use the direction indicator as a heading reference during VDF navigation assistance should reset the direction indicator to the magnetic compass before requesting VDF navigation assistance. Thereafter, the direction indicator should not be reset without advising the VDF operator.

1.6.4 Procedures

Pilots requesting VDF navigation assistance will be asked to provide the VDF operator with the following information:

- (a) the position of aircraft, if known; and
- (b) the altitude.

In order to derive VDF information from the radio signals transmitted from the aircraft, when asked to “transmit for bearing” pilots should transmit the aircraft call-sign, hold the microphone button for a few seconds, and repeat their call-sign.

Pilots receiving VDF navigation assistance retain their responsibility to see and avoid other traffic, to maintain appropriate terrain and obstacle clearance, and to remain in VFR weather conditions.

Example:

Pilot: *KINGSTON RADIO. THIS IS PIPER GOLF HOTEL GOLF BRAVO. REQUEST VDF NAVIGATION ASSISTANCE. APPROXIMATELY TWENTY MILES NORTHEAST OF KINGSTON, AT FIVE THOUSAND.*

Based on the aircraft's VDF bearing indication, the VDF operator will provide the pilot with the aircraft's reciprocal heading to the VDF site.

VDF operator: *GOLF HOTEL GOLF BRAVO, KINGSTON RADIO, TRANSMIT FOR BEARING.*

VDF operator: *GOLF HOTEL GOLF BRAVO, YOUR HEADING TO THE AIRPORT* IS TWO-TWO ZERO.*

***NOTE:** In instances where the VDF site is located more than one mile from the airport, the VDF operator will transmit to the pilot: "YOUR HEADING TO THE VDF SITE IS..."

1.7 ATC CLEARANCES, INSTRUCTIONS AND INFORMATION

Whenever an ATC clearance is received and accepted by the pilot, compliance shall be made with the clearance. If a clearance is not acceptable, the pilot should immediately inform ATC of this fact since acknowledgement of the clearance alone will be taken by a controller as indicating acceptance. For example, upon receiving a clearance for takeoff, the pilot should acknowledge the clearance and take off without undue delay or, if not ready to take off at that particular time, inform ATC of his or her intentions, in which case the clearance may be changed or cancelled.

A pilot shall comply with an ATC instruction that is directed to and received by the pilot, provided the safety of the aircraft is not jeopardized.

A clearance will be identified by the use of some form of the word "clear" in its contents. An instruction will always be worded in such a manner as to be readily identified, although the word "instruct" will seldom be included. Pilots shall comply with and acknowledge receipt of all ATC instructions directed to and received by them (CAR 602.31).

CAR 602.31 permits pilots to deviate from an ATC instruction or clearance in order to follow TCAS/ACAS resolution advisories. Pilots responding to a resolution advisory shall advise the appropriate ATC unit of the deviation as soon as practicable and shall expeditiously return to the last ATC clearance received and accepted, or the last ATC instruction received and acknowledged prior to the resolution advisory manoeuvre. Aircraft manoeuvres conducted during a resolution advisory should be kept to the minimum necessary to satisfy the resolution advisory. For more information on TCAS/ ACAS, see RAC 12.15.2.

ATC is not responsible for the provision of IFR separation to an IFR aircraft which carries out a TCAS or an ACAS resolution advisory manoeuvre until one of the following conditions exist:

- (a) the aircraft has returned to the last ATC clearance received and accepted, or last ATC instruction received and acknowledged prior to the resolution advisory; or
- (b) an alternate ATC clearance or instruction has been issued.

TCAS or ACAS does not alter or diminish the pilot-in-command's responsibility to ensure safe flight. Since TCAS/ACAS does not respond to aircraft which are not transponder-equipped or aircraft with a transponder failure, TCAS/ACAS alone does not ensure safe operation in every case. The services provided by ATC units are not predicated upon the availability of TCAS or ACAS equipment in an aircraft.

It should be remembered that control is predicated on known air traffic only and, when complying with clearances or instructions, pilots are not relieved of the responsibility for practising good airmanship.

A clearance or instruction is only valid WHILE IN CONTROLLED AIRSPACE. Pilots crossing between controlled and uncontrolled airspace should pay close attention to the terrain and obstacle clearance requirements.

ATS personnel routinely inform pilots of conditions, observed by others or by themselves, which may affect flight safety and are beyond their control. Examples of such conditions are observed airframe icing and bird activity. These are meant solely as assistance or reminders to pilots and are not intended in any way to absolve the pilot of the responsibility for the safety of the flight.

1.8 FLIGHT PRIORITY

1.8.1

Normally, ATC provides control service on a first-come, first-served basis. However, controllers may adjust the arrival or departure sequence in order to facilitate the maximum number of aircraft movements with the least average delay. Altitude assignment may also be adjusted in order to accommodate the maximum number of aircraft at their preferred altitudes, or to comply with ATFM requirements.

Flight priority is provided to:

- (a) an aircraft that is known or believed to be in a state of emergency;

NOTE: This category includes aircraft subjected to unlawful interference or other distress or urgency conditions that may compel the aircraft to land or require flight priority.

- (b) a MEDEVAC flight;
- (c) military or civilian aircraft participating in SAR missions and identified by the radiotelephony call sign “RESCUE” and the designator “RSCU,” followed by an appropriate flight number;
- (d) military aircraft that are departing on:
 - (i) operational air defence flights,
 - (ii) planned and co-ordinated air defence training exercises, and
 - (iii) exercises to an altitude reservation; or
- (e) an aircraft carrying Her Majesty the Queen, the Governor General, the Prime Minister, heads of state, or foreign heads of government.

1.8.2 Minimum Fuel Advisory

Pilots may experience situations where delays caused by traffic, weather or any other reason, result in the pilot being concerned about the aircraft’s fuel state upon reaching destination. In such cases, the pilot may declare to ATC that a MINIMUM FUEL condition exists. A MINIMUM FUEL declaration requires that the pilot:

- (a) advise ATC as soon as possible that a MINIMUM FUEL condition exists;
- (b) following an ATC communications transfer, advise the new sector or unit that a MINIMUM FUEL condition exists;
- (c) be aware that this is not an emergency situation, but merely an advisory that indicates an emergency is possible should any undue delay occur;
- (d) be aware that a minimum fuel advisory does not imply an ATC traffic priority although ATC special flight handling will be implemented; and
- (e) declare an EMERGENCY if the pilot determines that the remaining usable fuel supply suggests the need for ATC traffic priority to ensure a safe landing. In this case, the pilot should indicate low fuel as the reason for the emergency and report to ATC the fuel remaining in minutes of flight.

ATC will take the following special flight handling action when advised that a MINIMUM FUEL condition exists:

- (a) Be alert for any occurrence or situation that might delay the concerned aircraft and attempt to resolve any conflicts;
- (b) Inform the aircraft of any anticipated delay as soon as becoming aware of such a delay;
- (c) Inform the next sector or unit of the minimum fuel condition of the aircraft;
- (d) Record the information in the unit log; and
- (e) Be aware that an emergency situation may develop following a MINIMUM FUEL declaration.

In an effort to avoid confusion and to ensure that the appropriate ATC responses are provided, any non-standard phraseology used by the pilot referring to fuel or fuel shortage will cause ATC to immediately inquire if the pilot is declaring an emergency. Traffic priority will be given to a pilot who declares an emergency for fuel.

1.9 TRANSPONDER OPERATION

1.9.1 General

Transponders substantially increase the capability of radar to detect aircraft, and the use of automatic pressure altitude reporting equipment (Mode C) enables controllers to quickly determine where potential conflicts could occur. Proper transponder operating procedures and techniques will provide both VFR and IFR aircraft with a higher degree of safety. In addition, proper usage of transponders with Mode C capability will result in reduced communications and more efficient service.

When pilots receive ATC instructions concerning transponder operation, they shall operate transponders as directed until receiving further instructions or until the aircraft has landed, except in an emergency, communication failure or hijack.

ATC radar units are equipped with alarm systems that respond when the aircraft is within radar coverage and the pilot selects the emergency, communication failure or hijack transponder code. It is possible to unintentionally select these codes momentarily when changing the transponder from one code to another. To prevent unnecessary activation of the alarm, pilots should avoid inadvertent selection of 7500, 7600 or 7700 when changing the code if either of the first two digits to be selected is a seven. For example, if it is necessary to change from Code 1700 to Code 7100, first change to Code 1100, then Code 7100, NOT Code 7700 and then Code 7100. Do not select “STANDBY” while changing codes as this will cause the target to be lost on the ATC radar screen.

Pilots should adjust transponders to “STANDBY” while taxiing for takeoff, to “ON” (or “NORMAL”) as late as practicable before takeoff, and to “STANDBY” or “OFF” as soon as practicable after landing. In practice, transponders should be turned on only upon entering the active runway for departure and turned off as soon as the aircraft exits the runway after landing.

When the transponder or the automatic pressure altitude reporting equipment (Mode C) fails during flight where its use is mandatory, an aircraft may be operated to the next airport of intended landing and, thereafter, to complete an itinerary or to a repair base, if authorized by ATC.

ATC may, upon receiving a request, authorize an aircraft not equipped with a functioning transponder or Mode C to operate in airspace where its use is mandatory. The purpose of this advanced written request is to enable ATC to determine if the operation of the aircraft can be handled in the airspace at the time requested without compromising the safety of air traffic. Approval may be subject to such conditions and limitations deemed necessary to preserve safety. Pilots must obtain approval before entering airspace within which it is mandatory to be equipped with a functioning transponder and automatic pressure altitude reporting equipment. (This includes aircraft proposing to take off from an airport located within that airspace.)

1.9.2 Transponder Requirements

CAR 605.35 outlines the transponder operating rule, as well as the circumstance in which operation with an unserviceable transponder is permitted. It also outlines the procedures to follow in order to operate an aircraft within transponder airspace without being equipped with a transponder and automatic pressure-altitude reporting equipment. CAR 601.03 states that transponder airspace consists of:

- (a) all Class A, B and C airspace as specified in the *Designated Airspace Handbook*; and
- (b) any Class D or E airspace specified as transponder airspace in the *Designated Airspace Handbook*.

This includes all Class E airspace extending upwards from 10 000 ft ASL up to and including 12 500 ft ASL within radar coverage, as shown in Figure 1.1.

Pilots of IFR aircraft operating within controlled or uncontrolled high-level airspace should adjust their transponder to reply on Mode A, Code 2000 and on Mode C, unless otherwise instructed by ATC.

NOTE: Pilots instructed to squawk a discrete code should not adjust their assigned transponder code when informed that radar or surveillance service is terminated, except as specified in RAC 11.14. The termination of radar or surveillance service does not necessarily constitute direction to change to Code 2000.

Figure 1.1 – Transponder Airspace

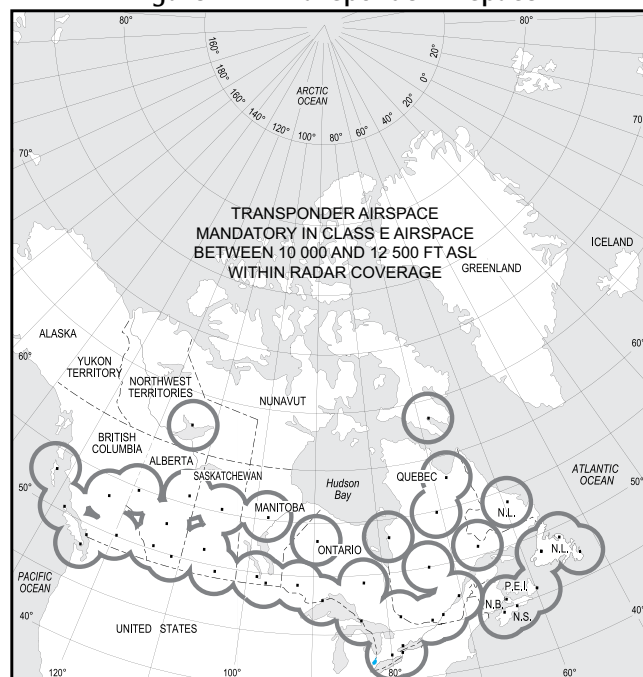

1.9.3 IFR Operations in Other Low Level Airspace

During IFR flight in controlled low level airspace other than that described in RAC 1.9.2, adjust your transponder to reply on Mode A, Code 1000, and on Mode C (if available), unless otherwise instructed by ATC. If an IFR flight plan is cancelled or changed to a VFR flight plan, the transponder should be adjusted to reply on the appropriate VFR code, as specified in the following paragraphs, unless otherwise instructed by ATC.

To enhance the safety of IFR flight in uncontrolled low level airspace, pilots are encouraged to adjust their transponders to reply on Mode A, Code 1000, plus Mode C (if available), unless otherwise instructed by ATC.

1.9.4 VFR Operations

During VFR flight in low-level airspace, adjust your transponder to reply on the following unless otherwise assigned by an ATS unit:

- (a) Mode A, Code 1200, for operation at or below 12 500 ft ASL; or
- (b) Mode A, Code 1400, for operation above 12 500 ft ASL.

RAC

Upon leaving the confines of an airspace for which a special Code assignment has been received, the pilot is responsible for changing to the Code shown in (a) or (b), unless assigned a new Code by an ATS unit.

NOTE: When climbing above 12 500 ft ASL, pilot should select Code 1200 until he/ she leaves 12 500 ft ASL, then select Code 1400. When descending from above 12 500 ft ASL, a VFR pilot should select Code 1200 upon reaching 12 500 ft ASL. Aircraft equipped with a transponder capable of Mode C automatic altitude reporting should adjust their transponder to reply on Mode C when operating in Canadian airspace unless otherwise assigned by an ATS unit.

1.9.5 Phraseology

ATS personnel will use the following phraseology when referring to transponder operation.

SQUAWK (code) – Operate transponder on designated Code in Mode A.

SQUAWK IDENT – Engage the “IDENT” feature of the transponder.

NOTE: A pilot should operate the identification (“IDENT”) feature only when requested by an ATS unit.

SQUAWK CHARLIE – Activate Mode C with automatic altitude reporting.

STOP SQUAWK CHARLIE – Turn off automatic altitude reporting function.

RESET TRANSPONDER – Reset your transponder, and transmit the SQUAWK (code) currently assigned. This phraseology may be used if the target or identity tag data is not being displayed as expected.

REPORT YOUR ALTITUDE – This phraseology may be used when it is necessary to validate altitude readouts by comparing the readouts value with an altitude reported by the aircraft. An altitude readout is considered valid if the readout value does not differ from the aircraft-reported altitude by more than 200 ft, and invalid if the difference is 300 ft or more.

NOTE: Readout values are displayed in 100–ft increments.

Example:

SQUAWK STANDBY – SQUAWK (code) - The PPS disappears or changes to a PSR symbol after the aircraft is instructed to change its transponder to “standby” and the PPS reappears or changes back to an SSR symbol after the aircraft is requested to return the transponder to normal operation.

1.9.6 Emergencies

In the event of an emergency and if unable to establish communication immediately with an ATC unit, a pilot wishing to alert ATC to the emergency situation should adjust the transponder to reply on Code 7700. Thereafter, communication should be established with ATC as soon as possible, and the transponder should be operated as directed by ATC.

1.9.7 Communication Failure

In the event of a communication failure, the pilot should adjust the transponder to reply on Code 7600 to alert ATC to the situation. This does not relieve the pilot of the requirement to comply with the appropriate communications failure procedures for IFR flight.

1.9.8 Unlawful Interference (Hijack)

Canada, along with other nations, has adopted a special SSR transponder code (7500) for use by pilots whose aircraft are hijacked. ATC does not assign this code unless the pilot informs ATC of a hijack in progress.

Selection of the code activates an alarm system and points out the aircraft on radar displays. If the controller doubts that an aircraft is being hijacked (as could occur when a code change was requested and the hijack code appeared, rather than the assigned code), the controller will say, CONFIRM SQUAWK SEVEN FIVE ZERO ZERO. If the pilot answers yes, the controller will alert the ATC system. If the pilot replies no, the controller will re-assign the proper code. If the pilot does not reply, the controller will take this as confirmation that the use of code 7500 is intentional. If, after using code 7500, an aircraft changes to code 7700, or transmits a message including the phrase TRANSPONDER SEVEN SEVEN ZERO ZERO, it indicates that the aircraft is threatened by grave and imminent danger and requires immediate assistance.

1.10 COLLISION AVOIDANCE—RIGHT OF WAY (CARs)

Reckless or Negligent Operation of Aircraft

602.01

No person shall operate an aircraft in such a reckless or negligent manner as to endanger or be likely to endanger the life or property of any person.

Right-of-Way – General**602.19**

- (1) Notwithstanding any other provision of this section,
 - (a) the pilot-in-command of an aircraft that has the right-of-way shall, if there is any risk of collision, take such action as is necessary to avoid collision; and
 - (b) where the pilot-in-command of an aircraft is aware that another aircraft is in an emergency situation, the pilot-in-command shall give way to that other aircraft.
- (2) When two aircraft are converging at approximately the same altitude, the pilot-in-command of the aircraft that has the other on its right shall give way, except as follows:
 - (a) a power-driven, heavier-than-air aircraft shall give way to airships, gliders and balloons;
 - (b) an airship shall give way to gliders and balloons;
 - (c) a glider shall give way to balloons; and
 - (d) a power-driven aircraft shall give way to aircraft that are seen to be towing gliders or other objects or carrying a slung load.
- (3) When two balloons operating at different altitudes are converging, the pilot-in-command of the balloon at the higher altitude shall give way to the balloon at the lower altitude.
- (4) Where an aircraft is required to give way to another aircraft, the pilot-in-command of the first-mentioned aircraft shall not pass over or under, or cross ahead of, the other aircraft unless passing or crossing at such a distance as will not create any risk of collision.
- (5) Where two aircraft are approaching head-on or approximately so and there is a risk of collision, the pilot-in-command of each aircraft shall alter its heading to the right.
- (6) An aircraft that is being overtaken has the right-of-way and the pilot-in-command of the overtaking aircraft, whether climbing, descending or in level flight, shall give way to the other aircraft by altering the heading of the overtaking aircraft to the right, and no subsequent change in the relative positions of the two aircraft shall absolve the pilot-in-command of the overtaking aircraft from this obligation until that aircraft has entirely passed and is clear of the other aircraft.
- (7) Where an aircraft is in flight or manoeuvring on the surface, the pilot-in-command of the aircraft shall give way to an aircraft that is landing or about to land.
- (8) The pilot-in-command of an aircraft that is approaching an aerodrome for the purpose of landing shall give way to any aircraft at a lower altitude that is also approaching the aerodrome for the purpose of landing.

- (9) The pilot-in-command of an aircraft at a lower altitude, as described in subsection (8), shall not overtake or cut in front of an aircraft at a higher altitude that is in the final stages of an approach to land.
- (10) No person shall conduct or attempt to conduct a takeoff or landing in an aircraft until there is no apparent risk of collision with any aircraft, person, vessel, vehicle or structure in the takeoff or landing path.

Right-of-Way – Aircraft Manoeuvring on Water**602.20**

- (1) Where an aircraft on the water has another aircraft or a vessel on its right, the pilot-in-command of the first-mentioned aircraft shall give way.
- (2) Where an aircraft on the water is approaching another aircraft or a vessel head-on, or approximately so, the pilot-in-command of the first-mentioned aircraft shall alter its heading to the right.
- (3) The pilot-in-command of an aircraft that is overtaking another aircraft or a vessel on the water shall alter its heading to keep well clear of the other aircraft or the vessel.

Avoidance of Collision**602.21**

No person shall operate an aircraft in such proximity to another aircraft as to create a risk of collision.

Formation Flight**602.24**

No person shall operate an aircraft in formation with other aircraft except by pre-arrangement between.

- (a) the pilots-in-command of the aircraft; or
- (b) where the flight is conducted within a control zone, the pilots-in-command and the appropriate air traffic control unit.

1.11 AEROBATIC FLIGHT (CARs 602.27 AND 602.28)

Aerobatic Manoeuvres – Prohibited Areas and Flight conditions**602.27**

No person operating an aircraft shall conduct aerobatic manoeuvres

- (a) over a built-up area or an open-air assembly of persons;
- (b) in controlled airspace, except in accordance with a special flight operations certificate issued pursuant to Section 603.67;

- (c) when flight visibility is less than three miles; or
- (d) below 2 000 feet AGL, except in accordance with a special flight operations certificate issued pursuant to Section 603.02 or 603.67.

Aerobatic Manoeuvres with Passengers

602.28

No person operating an aircraft with a passenger on board shall conduct aerobatic manoeuvres unless the pilot-in-command of the aircraft has engaged in

- (a) at least 10 hours dual flight instruction in the conducting of aerobatic manoeuvres or 20 hours conducting aerobatic manoeuvres; and
- (b) at least one hour of conducting aerobatic manoeuvres in the preceding six months.

1.12 PILOT REPORTS

1.12.1 General

Pilots are requested to make the following reports in the interests of national security, meteorite research and forest fire and pollution control.

1.12.2 CIRVIS Reports – Vital Intelligence Sightings

CIRVIS reports should be made immediately upon a vital intelligence sighting of any airborne and ground objects or activities which appear to be hostile, suspicious, unidentified or engaged in possible illegal smuggling activity.

Examples of events requiring CIRVIS reports are: unidentified flying objects, submarines, or surface warships identified as being non-Canadian or non-American; violent explosions; unexplained or unusual activity, including the presence of unidentified or suspicious ground parties in Polar regions, at abandoned airstrips or other remote, sparsely populated areas.

These reports should be made to the nearest Canadian or U.S. government FIC or ATC unit.

A report via air/ground communications should include the words “CIRVIS CIRVIS CIRVIS”, followed by:

- (a) the identification of the reporting aircraft;
- (b) a brief description of the sighting (number, size, shape, etc.);
- (c) the position of the sighted object or activity;
- (d) the date and time of sighting in UTC;

- (e) the altitude of the object;
- (f) the direction of movement of the object;
- (g) the speed of the object; and
- (h) any identification.

1.12.3 Meteorite Reports

Reports of spectacular meteors (fireballs), which may be bright enough to cast shadows, that may be accompanied by a “sonic boom”, that may trail glowing particles, and that may explode with a burst of light and a loud sound several times in flight, should be reported by radio to the nearest ATS unit or to:

Meteorites and Impacts Advisory Committee (MIAC)
<http://miac.uqac.ca>

Fax: 403-284-0074

1.12.4 Fire Detection – Northern Areas

The Department of Indian and Northern Affairs have requested the co-operation of all persons connected with aviation, in the prevention, detection and suppression of fires in the northern areas of Canada.

If smoke or other indications of fire are seen in any area, the local Forestry Warden, Game Management Officer, or member of the RCMP should be notified at once. If they are not available, the fire should be reported by collect telephone call to:

- (a) Superintendent of Forestry, Fort Smith, Northwest Territories, for fires in the Northwest Territories and Wood Buffalo National Park. [Tel. no. (867) 872-7700].
- (b) Superintendent of Forestry, Whitehorse, Yukon Territory, for fires in the Yukon Territory. [Tel. no. 1-888-798-FIRE(3473)].

Reports should give the size and location of the fire, and the name and address of the person making the report. This information will assist fire crews in getting to fires with minimum delay and with the right type of equipment.

1.12.5 Pollution Reports

Any aircraft in the airspace above Canadian waters, Fishing Zones or Arctic Shipping Control Zones should inform the nearest Canadian FIC upon sighting any vessel discharging pollutants (oil) in Canadian waters, Fishing Zones or Arctic Shipping Control Zones.

On the east and west coasts, the waters extend to approximately 200 NM from the coast line. In the north, the area includes virtually all of the waters in the Canadian Arctic.

The FIC will relay any reported pollution incidents to the appropriate Coast Guard Centres.

1.13 ATS REPORTS—POSSIBLE CONTRAVENTION OF THE CANADIAN AVIATION REGULATIONS (CARs)

Under current regulation, ATS units are required to report to the Minister of Transport any aviation occurrence that may contravene the CARs.

Any investigation of the circumstances or subsequent decision on whether a breach has taken place is the responsibility of TC. Any necessary follow-up action will be conducted by TC Civil Aviation regulatory authorities.

1.14 CONSERVATION

1.14.1 Fur and Poultry Farms

Experience has shown that aviation noise caused by rotary wing and fixed wing aircraft flying at low altitudes can cause serious economic losses to the farming industry. The classes of livestock particularly sensitive are poultry (including ostriches and emus), because of the crowding syndrome and stampeding behaviour they exhibit when irritated and frightened, and foxes who, when excited, will eat or abandon their young. Avoid overflying these farms below 2 000 feet AGL.

Fur farms may be marked with chrome yellow and black strips painted on pylons or roofs. In addition, a red flag may be flown during whelping season (February – May).

Pilots are, therefore, warned that any locations so marked should be avoided and that during the months of February, March, April and May, special vigilance should be maintained.

1.14.2 Protection of Wildlife

It is desired to impress on all pilots the importance of wildlife conservation; to urge them to become familiar with the game laws in force in the various provinces; and to co-operate with all game officers to see that violations of game laws do not occur.

The following is a list of addresses where Provincial and Territorial Game Officers may be contacted in Canada. To obtain information with regard to the preservation of wildlife within the various provinces, please contact a game officer at one of the locations shown below. Information pertaining to the migratory bird regulations may be obtained directly from the Director General, Canadian Wildlife Service, Environment Canada, Ottawa ON K1A 0H3.

Natural Resources Services
Wildlife Management Division
Department of Environmental Protection
Petroleum Plaza, North Tower
9945 108 Street
Edmonton AB T5K 2G6

Tel.:780-427-6733
Fax:780-422-9557

Fish and Wildlife Branch
Dept. of Natural Resources and Energy
Province of New Brunswick
P.O. Box 6000
Fredericton NB E3B 5H1

Tel.:506-453-3826
Fax:506-453-6699

Wildlife Management Division
Department of Renewable Resources
Gov. of the Northwest Territories
600–5102 50th Avenue
Yellowknife NT X1A 3S8 Tel.:867-873-7411
Fax:867-873-0293

Wildlife Branch
Min. of Environment, Lands and Parks
Province of British Columbia
Parliament Buildings
Victoria BC V8V 1X4
Tel.:250-387-9717
Fax:250-356-9154

Wildlife Branch
Department of Natural Resources
Province of Manitoba
P.O. Box 24
1495 St. James Street, Room 100
Winnipeg MB R3H 0W9
Tel.:204-945-6799
Fax:204-945-3077

Wildlife Division
Department of Natural Resources
Province of Newfoundland and Labrador
P.O. Box 8700
St. John’s NL A1B 4J6
Tel.:709-729-2630
Fax:709-729-6629

Wildlife Division
Department of Natural Resources
Province of Nova Scotia
136 Exhibition Street
Kentville NS B4N 4E5
Tel.:902-679-6091
Fax:902-679-6176

Terrestrial Ecosystems Branch
Ministry of Natural Resources
Province of Ontario
90 Sheppards Avenue East, 6th Floor
North York ON M2N 3A1
Tel.:416-314-1069
Fax:416-314-1049



Fish and Wildlife Division
 Dept. of Environmental Resources
 Province of Prince Edward Island
 P.O. Box 2000
 11 Kent Street, 4th Floor
 Charlottetown PE C1A 7N8

Tel: 902-368-4684
 Fax: 902-368-5830

Société de la faune et des parcs du Québec
 Centre d'information
 Édifice Marie-Guyart, r.-d.-c.
 675, boulevard René-Lévesque Est
 Québec (Québec) G1R 5V7

Tel.: 418 521-3830
 Fax: 418 646-5974

Wildlife Branch
 Environment and Resource Mgmt.
 Province of Saskatchewan
 3211 Albert Street
 Regina SK S4S 5W6

Tel.: 306-787-2314
 Fax: 306-787-9544

Fish and Wildlife Branch
 Department of Environment
 Government of Yukon
 P.O. Box 2703, 10 Burns Road
 Whitehorse YT Y1A 2C6

Tel.: 877-667-5715
 Toll free (in Yukon): 1-800-661-0408 ext. 5715
 Fax: 867-393-6405

Department of Sustainable Development
 Wildlife and Environmental Protection
 Government of Nunavut
 Iqaluit NU

Tel.: 867-975-5902
 Fax: 867-975-5980

1.14.3 Reindeer, Caribou, Moose and Muskoxen Conservation

Pilots should be aware that flying low over herds of reindeer, caribou, moose or muskoxen may result in reducing the animal population. Accidents resulting in broken bones may increase. Exhausted and disorganized animals are more susceptible to be attacked by wolves; feeding is interrupted; and normal herd movement and reproductive functions may be seriously disrupted.

It is important that all pilots flying aircraft in the north country realize the value of these animals to native welfare. The co-operation of all is requested in eliminating any action which might lead to unnecessary losses of these valuable animals.

Pilots should not fly at an altitude less than 2 000 feet AGL when in the vicinity of herds of reindeer or caribou.

1.14.4 Migratory Bird Protection

The migratory bird regulations prohibit the killing of game birds through the use of an aircraft.

Pilots should be aware that serious damage can be done to migratory bird harvest areas due to low flying aircraft. Geese particularly are in great fear of aircraft; and their movements may be seriously disorganized by such interference. These geese are a valuable asset to Canada. As several species are nearing extinction, it is felt that every effort should be made to preserve them.

1.14.5 National, Provincial and Municipal Parks, Reserves and Refuges

To preserve the natural environment of parks, reserves and refuges and to minimize the disturbance to the natural habitat, overflights should not be conducted below 2 000 feet AGL.

The landing or takeoff of aircraft in the national parks and national park reserves may take place at prescribed locations.

To assist pilots in observing this, boundaries are depicted on the affected charts. The following is taken from *the National Parks Aircraft Access Regulations* (98-01-29):

- (1) Subject to subsection (2) and Section 5 no person shall take off or land an aircraft in a park except in a park set out in column I of an item of the schedule, at a take-off and landing location set out in column II of that item.
- (2) No person shall take off or land an aircraft in a park set out in column I of any of items 1 to 6 of the schedule unless that person holds a permit.

Schedule (Sections 2 and 5)

<i>Item</i>	<i>Column I Park</i>	<i>Column II Take-off and Landing Location</i>
1.	Auyuittuq Reserve	Any location
2.	Ellesmere Island Reserve	Any location
3.	Northern Yukon National	(a) Margaret Lake at latitude 68°50'00"N, longitude 140°08'48"W (b) Nunaluk Spit at latitude 69°34'17"N, longitude 139°32'48"W (c) Sheep Creek at latitude 69°10'07"N, longitude 140°08'48"W (d) Stokes Point at latitude 69°19'49"N, longitude 138°44'13"W
4.	Kluane Reserve	(a) Big Horn Lake at latitude 61°08'30"N, longitude 139°22'40"W (b) Quinteno Sella Glacier at latitude 60°36'20"N, longitude 140°48'30"W (c) Hubbard Glacier at latitude 60°34'00"N, longitude 140°07'30"W (d) Cathedral Glacier at latitude 60°14'15"N, longitude 138°58'00"W (e) South Arm Kaskawulsh Glacier at latitude 60°30'30"N, longitude 138°53'00"W
5.	Kluane National Park	(a) Lowell Lake and Lowell Lake Bar at latitude 60°17'10"N, longitude 137°57'00"W (b) Onion Lake at latitude 60°05'40"N, longitude 138°25'00"W
6.	Nahanni Reserve	(a) Rabbit kettle Lake at latitude 61°57'00"N, longitude 127°18'00"W (b) Virginia Falls at latitude 61°38'00"N, longitude 125°38'00"W
7.	Wood Buffalo National Park	Garden Creek Airstrip at latitude 58°42'30"N, longitude 113°53'30"W

1.15 WILDLIFE HAZARDS

1.15.1 Introduction

Trends indicate that there is a growing risk of collisions between wildlife and aircraft. This risk is due largely to corresponding increases in the populations of some hazardous species—such as deer, geese and gulls—and the numbers of aircraft operations across Canada.

All aviation stakeholders have a role to play in reducing the risks of wildlife strikes. Pilots can take three simple steps to help improve safety:

1. Increase awareness of wildlife and the hazards they pose to aviation.
2. Learn what risk-reduction and communication measures are in place at frequented airports.
3. Become familiar with the bird/wildlife strike report form, and be sure to file a report in the event of any wildlife encounter.

This section provides information to help pilots gain a better appreciation of:

- measures airports must take to identify and control wildlife hazards, and to communicate with pilots about these hazards;
- bird/wildlife-strike reporting procedures; and
- migratory bird activity.

1.15.2 Airport Wildlife Management

In force since May 16, 2006, a new CAR recognizes that lands on and around airports often provide food and shelter for wildlife species that can be hazardous to air travel. Division III of CAR 302—*Airport Wildlife Planning and Management*, requires most Canadian certified airports to minimize risks, primarily by identifying and countering potentially hazardous species. Airports that are subject to the regulation must develop, implement and maintain plans for the management of these species.



The process of identifying wildlife hazards and measuring the risks they pose is called risk analysis. Under CAR 302, an airport operator must conduct a risk analysis as one of the first steps in creating an airport wildlife management plan. Pilots should be aware that these analyses must include consultations with representative samples of airport users, such as flight schools, airlines and pilots.

1.15.3 Communication of Wildlife Hazards

Provisions of CAR 302 also require airport operators to put in place effective communication and alerting procedures to quickly notify pilots of wildlife hazards.

- Pilots should monitor ATIS and air-ground communications for information concerning wildlife hazards, particularly during spring and autumn migration periods when bird activity is at its peak. In unusual circumstances, a NOTAM may be used to identify these hazards.
- Pilots who encounter wildlife on an airport are asked to immediately:
 - notify ATIS, and
 - take appropriate steps to minimize the risk associated with their flight.
- Pilots who frequent Canadian certified airports are encouraged to ask about measures in place to ensure effective communication and to counter wildlife hazards.

1.15.4 Bird/Wildlife-Strike Reporting Procedures

To comply with CAR 302, airport wildlife management plans must be based on current wildlife-strike data, which is compiled by, and made available through, Transport Canada. Airports must report all bird/wildlife strikes to Transport Canada and keep records of these events; however, bird/wildlife strike reports can be filed by anyone, including airline personnel, ground crews and pilots.

Strike reporting is one of the most valuable contributions members of the aviation community can make in an effort to reduce wildlife risks. The data is vital to national and international airport wildlife management efforts, and one of the most important tools in tracking wildlife trends and determining hazards at locations across Canada.

Pilots are asked to report any knowledge of bird/wildlife strikes, no matter how inconsequential the event may seem. Even information about a near miss can help authorities learn more about the presence of potentially-hazardous species, and the nuances of encounters between aircraft and wildlife.

In cases of bird strikes, reports should include the species whenever possible. Species identification provides airport operators with important data that enables them to effectively focus risk mitigation efforts. If the species is unknown, but bird remains are available from the incident, pilots may consult with airport wildlife management personnel for help identifying the species. Airport personnel may also decide to submit the remains to the Smithsonian Institution, Division of Birds. Transport Canada maintains a formalized agreement with this organization for the purpose of species identification.

An important regulatory trigger

CAR 302 requires an airport operator to amend its wildlife management plan, and submit it to Transport Canada for review within 30 days of the amendment, if a turbine-powered aircraft:

- suffers damage as a result of a collision with wildlife other than a bird;
- collides with more than one bird; or
- ingests a bird through an engine.

This process of review and amendment helps ensure wildlife management plans are as current as possible, addressing continual fluctuations in the wildlife hazards at airports.

The review-and-amendment process is also set in motion when a variation in the presence of wildlife hazards is observed in an airport's flight pattern or movement area. Pilots can help mitigate risk by reporting to Transport Canada any significant changes in the numbers or behaviour of hazardous wildlife at airports that are visited regularly.

Bird/wildlife strike report form

Hard copy forms (form number 51-0272) are available in bulk from the Transport Canada Order Desk:

Web site: www.tc.gc.ca/transact
 Toll-free (North America only): 1-888-830-4911
 Local: 613-991-4071
 Fax: 613-991-2081
 E-mail: mps@tc.gc.ca

To complete and submit a bird/wildlife strike report online:

http://wwwapps.tc.gc.ca/Saf-Sec-Sur/2/bsis/s_r.aspx?lang=eng

Reports can also be made through a toll-free hotline:

1-888-282-BIRD (282-2473)

Figure 1.2 – Bird/Wildlife Strike Report

Transport Canada Safety and Security		Transports Canada Sécurité et sûreté			
Bird/Wildlife Strike Report			Rapport d'impact d'oiseau/de mammifère		
TYPE	<input type="checkbox"/> Bird Strike/Impact d'oiseau <input type="checkbox"/> Bird Near Miss/Quasi-impact d'oiseau	<input type="checkbox"/> Mammal Strike/Impact de mammifère <input type="checkbox"/> Mammal Near Miss/Quasi-impact de mammifère	DATE	LOCAL TIME HEURE LOCALE	
REPORTING SOURCE SOURCE DU RAPPORT	<input type="checkbox"/> Pilot/Pilote <input type="checkbox"/> Site <input type="checkbox"/> Other/Autre	<input type="checkbox"/> Airline/Compagnie aérienne <input type="checkbox"/> Museum/Musée	OPERATOR EXPLOITANT	HEIGHT (AGL,feet) ALTITUDE (AGL,pieds)	SPEED (IAS knots) VITESSE (vi-noeuds)
AIRCRAFT INFORMATION – INFORMATION SUR L'AÉRONEF					
Model/Modèle		Registration/Immatriculation		Engine Type/Type de moteur	
Make/Marque		Flight No./N ^o de vol		Engine Make/Marque du moteur	
AIRPORT AÉROPORT	Name/Nom	Code	Province	Region/Région	Runway/Piste
PHASE OF OPERATION PHASE DE L'OPÉRATION	<input type="checkbox"/> Takeoff Run/Roulement au décollage <input type="checkbox"/> Climb/Montée <input type="checkbox"/> En route/Croisière (Distance from Airport/Distance de l'aéroport)		<input type="checkbox"/> Approach/Approche <input type="checkbox"/> Descent/Descente	<input type="checkbox"/> Landing Roll/Roulement à l'atterrissage <input type="checkbox"/> Taxi/Circulation au sol <input type="checkbox"/> Parked/Stationnement	
PART(S) STRUCK/DAMAGED PARTIE(S) TOUCHÉE(S)/ ENDOMMAGÉE(S)	Struck Touchée	Damaged Endommagée	EFFECT(S) ON AIRCRAFT/FLIGHT EFFET(S) SUR L'AÉRONEF/LE VOL None Aucun Aborted Takeoff Décollage interrompu Precautionary Landing Atterrissage de précaution Engine(s) Shut Down Arrêt de(s) moteur(s) Forced Landing Atterrissage forcé Fire Feu Penetration of Airframe Pénétration de la cellule Vision Obscured Visibilité réduite Engine Ingestion Ingestion dans le moteur Engine Uncontained Failure Panne de moteur avec perforation Other Autre _____		
	Radome/Radôme				
	Windshield/Pare-brise				
	Nose/Partie avant de l'appareil				
	Engine/Moteur 1				
	Engine/Moteur 2				
	Engine/Moteur 3				
	Engine/Moteur 4				
	Propeller/Hélice				
	Wings/Ailes				
	Rotor/Rotor				
	Fuselage				
	Landing Gear/Train d'atterrissage				
	Tail/Queue				
	Lights/Feux				
Pitot Static/Antenne Pitot					
Tail Rotor/Rotor anticoupe					
Other/Autre _____					
			LIGHT CONDITION CONDITION D'ÉCLAIRAGE Dawn Aube Day Jour Dusk Crépuscule Night Nuit		
			SKY CONDITION ÉTAT DU CIEL No Cloud Pas de nuage Some Cloud Quelques nuages Overcast Couvert		
			PRECIPITATION PRÉCIPITATION Rain Pluie Fog Brouillard Snow Neige Other Autre _____		
BIRD / MAMMAL INFORMATION INFORMATION CONCERNANT L'OISEAU / LE MAMMIFÈRE					
SPECIES – COMMON NAME ESPÈCE – NOM COMMUN		SIZE OF BIRD TAILLE DE L'OISEAU		NUMBER OF BIRDS NOMBRE D'OISEAUX	
SCIENTIFIC NAME NOM SCIENTIFIQUE		<input type="checkbox"/> Small/Petit <input type="checkbox"/> Medium/Moyen <input type="checkbox"/> Large/Grand		Seen Aperçus	
				Struck Touchés	
				0	
				1	
				2-10	
11-100					
More/Plus					
BIRD REMAINS SUBMITTED FOR IDENTIFICATION? LES RESTES DE L'OISEAU ONT-ILS ÉTÉ EXPÉDIÉS POUR IDENTIFICATION?			<input type="checkbox"/> Yes/Oui <input type="checkbox"/> No/Non		
			PILOT WARNED OF BIRDS? PILOTE AVERTI DE LA PRÉSENCE DES OISEAUX?		
			<input type="checkbox"/> Yes/Oui <input type="checkbox"/> No/Non		

51-0272 (06-97)

RAC

Bird/Wildlife Strike Report

Rapport d'impact d'oiseau/de mammifère

INFORMATION ON ENGINE DAMAGE STRIKES

INFORMATION CONCERNANT LE MOTEUR ENDOMMAGÉ PAR L'IMPACT D'OISEAUX

Reason for Failure/Shutdown Raison de la panne/de l'arrêt du moteur	Engine Motor No. – N° du moteur				Comments – Commentaires
	1	2	3	4	
Engine Uncontained Failure Panne de moteur avec perforation des parois					
Fire Feu					
Shutdown - Vibration Arrêt-moteur - Vibrations					
Shutdown - Temperature Arrêt-moteur - Température					
Shutdown - Fire Warning Arrêt-moteur - Alarme incendie					
Shutdown - Arrêt-moteur Other (specify)/Autre (précisez)					
Shutdown Unknown Arrêt-moteur inconnu					
Estimated % of Thrust Lost Estimation en % de la perte de puissance					
Estimated Number of Birds Ingested Estimation du nombre d'oiseaux impliqués					

**ADDITIONAL INFORMATION
INFORMATION SUPPLÉMENTAIRE**

**COST INFORMATION
INFORMATION SUR LES COÛTS**

**DAMAGE CATEGORY (DND)
CATÉGORIE ENDOMMAGÉE (MDN)**

Aircraft Time Out of Service/ Durée de la mise hors service de l'aéronef	Estimated Cost of Repairs or Replacement/ Estimation des coûts de réparation ou de remplacement	Estimated Other Costs (e.g., Loss of Revenue, Hotels) Estimation des autres coûts(ex. perte de revenus, hôtels)
Hours Heures	\$CDN _____ (In Thousands/En milliers)	\$CDN _____ (In Thousands/En milliers)

REMARKS – REMARQUES

REPORT BY / DÉPOSÉ PAR: _____ DATE: _____
 ORGANIZATION / ORGANISATION: _____ TELEPHONE #/N° DE TÉLÉPHONE #: (____) _____

RAC

Figure 1.3(a) –Spring Migration Routes – Cranes, Ducks and Canada Geese

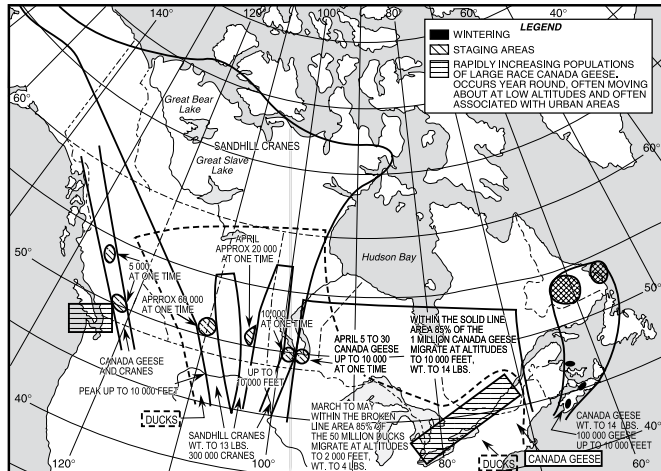

Figure 1.4(a) –Autumn Migration Routes – Cranes, Ducks and Canada Geese

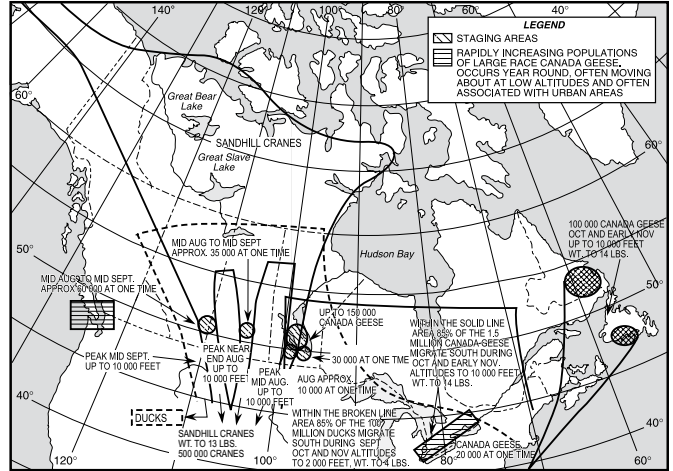

Figure 1.3(b) –Spring Migration Routes – Other Geese

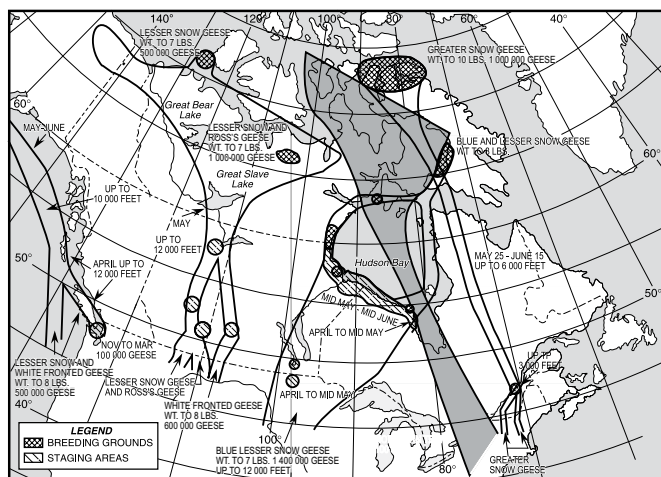

Figure 1.4(b) –Autumn Migration Routes – Other Geese

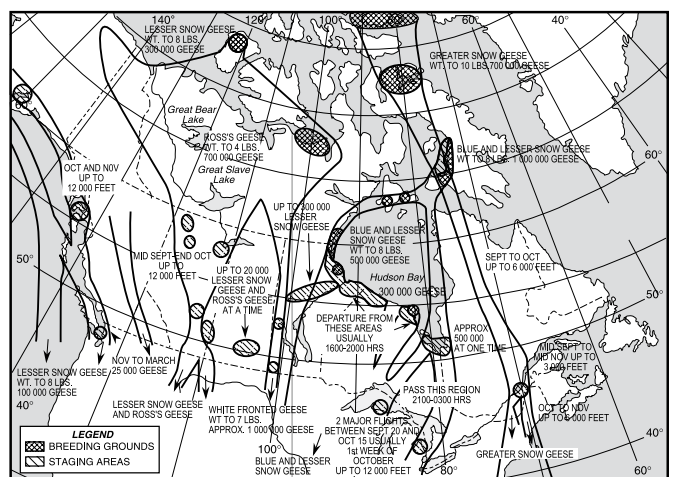

Figure 1.3(c) –Spring Migration Routes – Swans (Flight Altitudes to 12 000 feet)

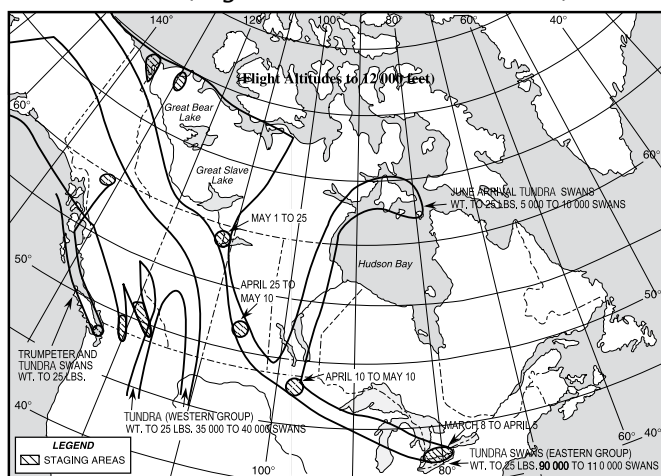
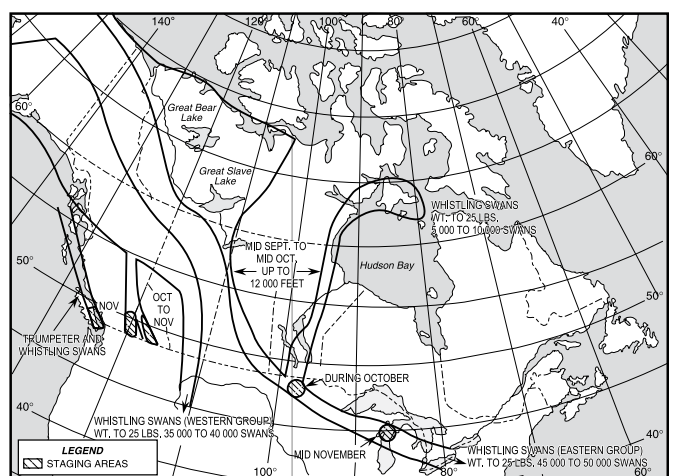

Figure 1.4(c) –Autumn Migration Routes – Swans



RAC

2.0 AIRSPACE – REQUIREMENTS AND PROCEDURES

2.1 GENERAL

Canadian airspace is divided into a number of categories, which in turn are subdivided into a number of areas and zones. The various rules are simplified by the classification of all Canadian airspace. This section describes all of the above in detail, as well as the regulations and procedures specific to each. The official designation of all airspace is published in the DAH. Canadian airspace is managed by NAV CANADA in accordance with the terms established for the transfer of the air navigation system (ANS) from government operation to NAV CANADA, and with the rights granted to the corporation pursuant to the *Civil Air Navigation Services Commercialization Act*.

2.2 CANADIAN DOMESTIC AIRSPACE

Canadian Domestic Airspace (CDA) includes all airspace over the Canadian land mass, the Canadian Arctic, Canadian Archipelago and those areas of the high seas within the airspace boundaries. These boundaries are depicted on the Enroute Charts.

2.2.1 Northern Domestic Airspace

Canadian Domestic Airspace is geographically divided into the Southern Domestic Airspace and the Northern Domestic Airspace as indicated in Figure 2.1. In the Southern Domestic Airspace, magnetic track is used to determine cruising altitude for direction of flight.

The Magnetic North Pole is located near the centre of the Northern Domestic Airspace, therefore magnetic compass indications may be erratic. Thus, in this airspace, runway heading is given in true and true track is used to determine cruising altitude for direction of flight in lieu of magnetic track.

Figure 2.1 – Boundaries of Canadian Domestic Airspace, Northern Domestic Airspace and Southern Domestic Airspace

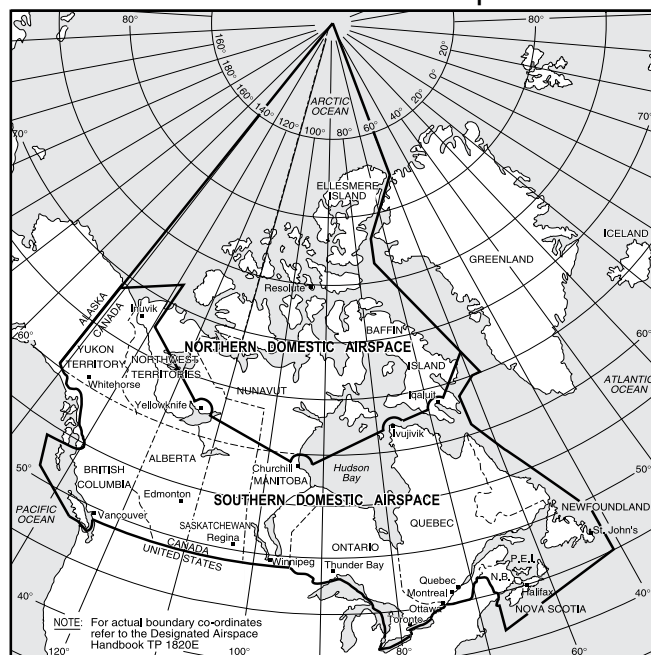

2.3 HIGH AND LOW LEVEL AIRSPACE

The CDA is further divided vertically into low level airspace, which consists of all of the airspace below 18 000 ft ASL; and high level airspace which consists of all airspace from 18 000 ft ASL and above.

2.3.1 Cruising Altitudes and Cruising Flight Levels Appropriate to Aircraft Track

General Provisions

1. The appropriate altitude or flight level for an aircraft in level cruising flight is determined in accordance with:
 - (a) the magnetic track, in SDA; and
 - (b) the true track, in NDA.
2. When an aircraft is operated in level cruising flight:
 - (a) at more than 3000 ft AGL, in accordance with VFR;
 - (b) in accordance with IFR; or
 - (c) during a CVFR flight.

The pilot-in-command of an aircraft shall ensure that the aircraft is operated at an altitude or flight level appropriate to the track, unless assigned an altitude or flight level by an ATC unit or by written authority from the Minister.

3. RVSM cruising flight levels appropriate to aircraft track are applicable in designated RVSM airspace.

4. The pilot-in-command of an aircraft operating within controlled airspace between 18 000 ft ASL and FL600, inclusive, shall ensure that the aircraft is operated in accordance with IFR unless otherwise authorized in writing by the Minister. (CAR 602.34)

- (c) Canadian protected airspace criteria for track separation will not be used.

Figure 2.2 – Flight Information Regions

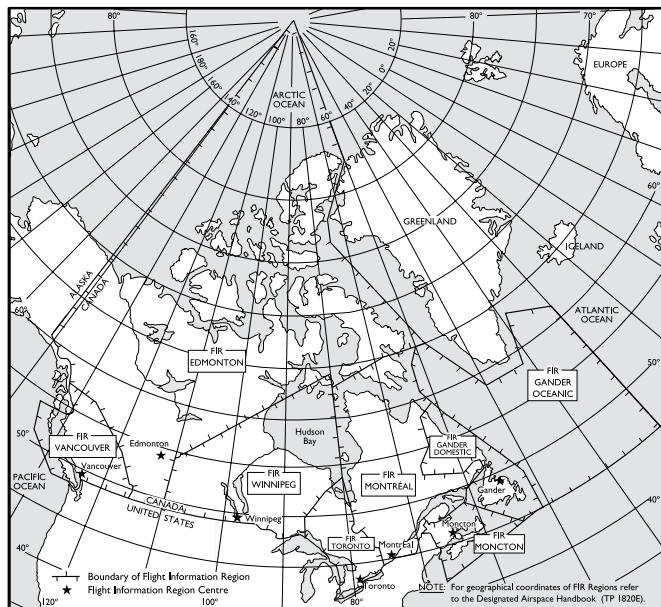

2.4 FLIGHT INFORMATION REGIONS

A Flight Information Region (FIR) is an airspace of defined dimensions extending upwards from the surface of the earth, within which flight information service and alerting services are provided. The Canadian Domestic Airspace is divided into the Vancouver, Edmonton, Winnipeg, Toronto, Montréal, Moncton and Gander Domestic Flight Information Regions. Gander Oceanic is an additional FIR allocated to Canada by ICAO for the provision of flight information and alerting services over the high seas.

Canadian Flight Information Regions are described in the *Designated Airspace Handbook (TP 1820E)*, and are depicted on the Enroute Charts and illustrated in Figure 2.2.

Agreements have been effected between Canada and the United States to permit reciprocal air traffic control services outside of the designate national FIR boundaries. An example is V300 and J500 between SSM and YQT. The control of aircraft in US airspace delegated to a Canadian ATC unit is effected by applying the Canadian rules, procedures and separation minima with the following exceptions:

- (a) aircraft will not be cleared to maintain “1 000 feet on top”;
- (b) ATC vertical separation will not be discontinued on the basis of visual reports from the aircraft; and

2.5 CONTROLLED AIRSPACE

Controlled airspace is the airspace within which air traffic control service is provided and within which some or all aircraft may be subject to air traffic control. Types of controlled airspace are:

- (a) in the High Level Airspace:
 - the Southern, Northern and Arctic Control Areas.

NOTE: Encompassed within the above are high level airways, the upper portions of some military terminal control areas and terminal control areas.

- (b) in the Low Level Airspace:
 - low level airways,
 - terminal control areas,
 - control area extensions,
 - control zones,
 - transition areas,
 - military terminal control areas.

2.5.1 Use of Controlled Airspace by VFR Flights

Due to the speeds of modern aircraft, the difficulty in visually observing other aircraft at high altitudes and the density of air traffic at certain locations and altitudes, the “see and be seen” principle of VFR separation cannot always provide positive separation. Accordingly, in certain airspace and at certain altitudes VFR flight is either prohibited or subject to specific restrictions prior to entry and during flight.

2.5.2 Aircraft Speed Limit Order

According to CAR 602.32, no person shall operate an aircraft in Canada;

- (a) below 10 000 ft ASL at an indicated airspeed of more than 250 kt; or
- (b) below 3 000 ft AGL within 10 NM of a controlled airport at an indicated airspeed of more than 200 kt unless authorized to do so in an air traffic control clearance.

Exceptions

- (a) A person may operate an aircraft at an indicated airspeed greater than the airspeeds referred to in (a) and (b) above where the aircraft is being operated in accordance with a special flight operations certificate – special aviation event issued under CAR 603.
- (b) If the minimum safe speed, given the aircraft configuration, is greater than the speed referred to in (a) or (b) above, the aircraft shall be operated at the minimum safe speed.

2.6 HIGH LEVEL CONTROLLED AIRSPACE

Controlled airspace within the High Level Airspace is divided into three separate areas. They are the Southern Control Area (SCA), the Northern Control Area (NCA) and the Arctic Control Area (ACA). Their lateral dimensions are illustrated in Figure 2.3. Figure 2.4 illustrates their vertical dimensions which are: SCA, 18 000 feet ASL and above; NCA, FL230 and above; ACA, FL270 and above. The volume and concentration of international air traffic transiting the NCA and ACA on random tracks can create enroute penalties to users by preventing maximum utilization of the airspace. To ensure the flow of traffic is accommodated efficiently, a track system has been established which interacts with the established airway system in the SCA and Alaska. Use of these tracks is mandatory at certain periods of the year.

Pilots are reminded that both the NCA and the ACA are within the Northern Domestic Airspace; therefore, compass indications may be erratic, and true tracks are used in determining the flight level at which to fly. In addition, the airspace from FL330 to FL410 within the lateral dimensions of the NCA, the ACA and the northern part of the SCA has been designated CMNPS airspace. Special procedures apply within this airspace. See RAC 12.5 for details.

Figure 2.3 – Southern, Northern and Arctic Control Areas

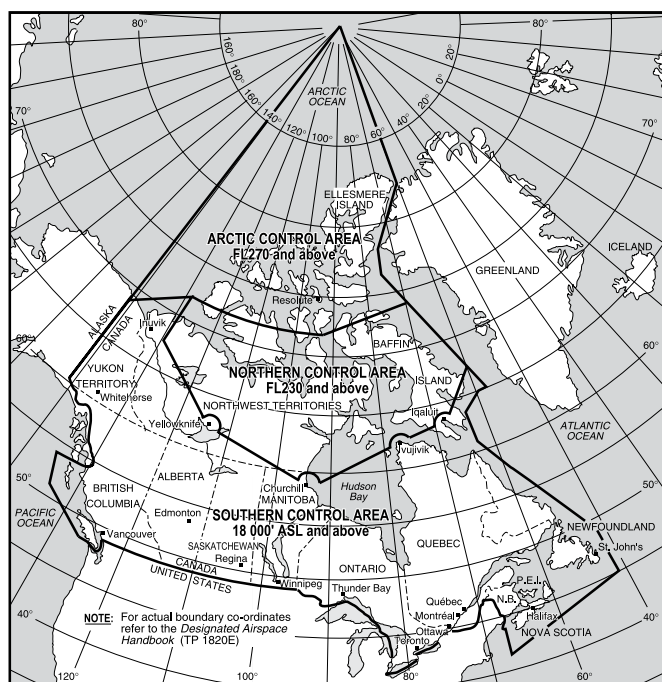
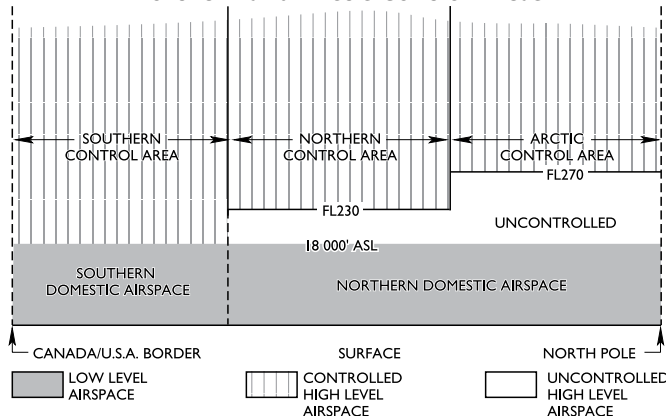

Figure 2.4 – Vertical Dimensions of Southern, Northern and Arctic Control Areas



2.7 LOW-LEVEL CONTROLLED AIRSPACE

2.7.1 Low-Level Airways

Controlled low-level airspace extends upward from 2 200 ft AGL up to, but not including, 18 000 ft ASL, within the following specified boundaries:

- (a) *VHF/UHF Airways*: The basic VHF/UHF airway width is 4 NM on each side of the centreline prescribed for such an airway. Where applicable, the airway width shall be increased between the points where lines, diverging 4.5° on each side of the centreline from the designated facility, intersect the basic width boundary; and where they meet, similar lines projected from the adjacent facility.

Figure 2.5(a) – VHF/UHF Airway Dimensions

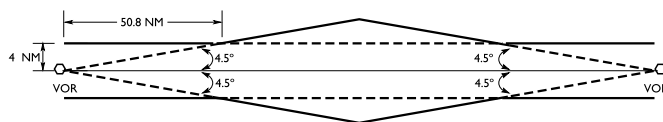

Where a Victor airway is established based on a VOR/VORTAC and NDB, the boundaries of that airway will be those of an LF/MF airway [see Figure 2.5(b)].

Figure 2.5(b) – VHF/UHF Airway Based on VOR and NDB

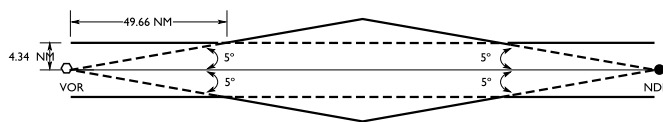

RAC

(b) *LF/MF Airways*: The basic LF/MF airway width is 4.34 NM on each side of the centreline prescribed for such an airway. Where applicable, the airway width shall be increased between the points where lines, diverging 5° on each side of the centreline from the designated facility, intersect the basic width boundary; and where they meet, similar lines projected from the adjacent facility.

Figure 2.6 – LF/MF Airway Dimensions

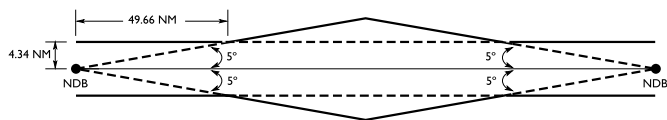

(c) *T-Routes*: Low-level controlled fixed RNAV routes have dimensions of 4 NM of primary obstacle protection area, plus 2 NM of secondary obstacle protection area on each side of the centreline. The airspace associated with RNAV T-routes is 10 NM on each side of the centreline. RNAV T-route airspace and protection areas do not splay.

Figure 2.7(a) – Fixed RNAV Route



Figure 2.7(b) – Fixed RNAV Route Cross Section

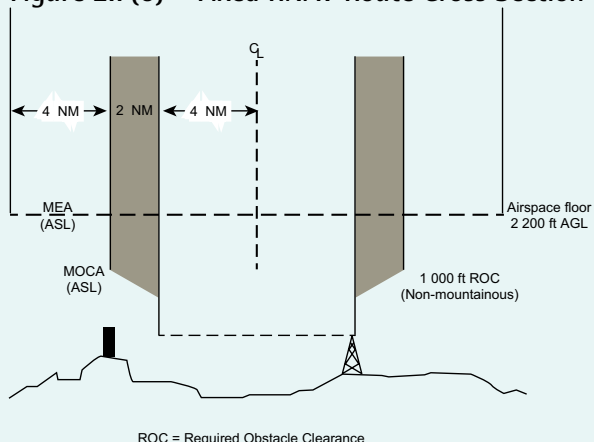

2.7.2 Control Area Extensions

Control area extensions are designated around aerodromes where the controlled airspace provided is insufficient to permit the required separation between IFR arrivals and departures and to contain IFR aircraft within controlled airspace. A control area extension provides:

- (a) additional controlled airspace around busy aerodromes for IFR control. The controlled airspace contained within the associated control zone and airway(s) width is not always sufficient to permit the manoeuvring required to separate IFR arrivals and departures; or
- (b) connecting controlled airspace, e.g., a control area extension is used to connect a control zone with the enroute structure.

Control area extensions are based at 2 200 ft AGL unless otherwise specified and extend up to, but not including 18 000 ft ASL. Some control area extensions, such as those which extend to the oceanic controlled airspace, may be based at other altitudes such as 2 000, 5 500 or 6 000 ft ASL. The outer portions of some other control area extensions may be based at higher levels. Even if described with an ASL floor, the base of a Control Area Extension shall not extend lower than 700 ft AGL.

2.7.3 Control Zones

Control zones are designated around certain aerodromes to keep IFR aircraft within controlled airspace during approaches and to facilitate the control of VFR and IFR traffic.

Control zones having a civil control tower within a terminal control area normally have a 7-NM radius. Others have a 5-NM radius, with the exception of a few which have a 3-NM radius. Control zones are capped at 3 000 feet AAE unless otherwise specified. Military control zones usually have a 10-NM radius and are capped at 6 000 feet AAE. All control zones are depicted on VFR aeronautical charts and the Enroute Low Altitude Charts. Control zones will be classified as “B”, “C”, “D” or “E” depending on the classification of the surrounding airspace.

The VFR weather minima for control zones are outlined in Figure 2.7. When weather conditions are below VFR minima, a pilot operating VFR may request special VFR (SVFR) authorization in order to enter the control zone. This authorization is normally obtained through the local tower or FSS, and must be obtained before SVFR is attempted within a control zone. ATC will issue an SVFR authorization, traffic and weather conditions permitting, only upon a request for SVFR from a pilot. SVFR will not be initiated by ATS. Once having received SVFR authorization, the pilot continues to remain responsible for avoiding other aircraft and weather conditions beyond the pilot’s own flight capabilities and the capabilities of the aircraft.

Figure 2.7 – VFR Weather Minima*

AIRSPACE		FLIGHT VISIBILITY	DISTANCE FROM CLOUD	DISTANCE AGL
Control Zones		not less than 3 miles**	horizontally: 1 mile vertically: 500 feet	vertically: 500 feet
Other Controlled Airspace		not less than 3 miles	horizontally: 1 mile vertically: 500 feet	—
Uncontrolled Airspace	1 000 feet AGL or above	not less than 1 mile (day) 3 miles (night)	horizontally: 2 000 feet vertically: 500 feet	—
	below 1 000 feet AGL – fixed-wing	not less than 2 miles (day) 3 miles (night) (see Note 1)	clear of cloud	—
	below 1 000 feet AGL – helicopter	not less than 1 mile (day) 3 miles (night) (see Note 2)	clear of cloud	—

* See CAR 602, Division VI – Visual Flight Rules

** Ground visibility when reported

NOTES 1: Notwithstanding CAR 602.115, an aircraft other than an helicopter may be operated in visibilities less than 2 miles during the day, when authorized to do so in an air operator certificate or in a private operator certificate.

2: Notwithstanding CAR 602.115, a helicopter may be operated in visibilities less than 1 mile during the day, when authorized to do so in an air operator certificate or in a flight training unit operator certificate helicopter.

Special VFR weather minimum and requirements applicable within control zones are found in CAR 602.117, and are summarized as follows:

Where authorization is obtained from the appropriate ATC unit, a pilot-in-command may operate an aircraft within a control zone, in IFR weather conditions without compliance with the IFR, where flight visibility and, when reported, ground visibility are not less than:

- (a) 1 mile for aircraft other than helicopters; and
- (b) 1/2 mile for helicopters.

NOTES 1: All aircraft, including helicopters, must be equipped with a radio capable of communicating with the ATC unit and must comply with all conditions issued by the ATC unit as part of the SVFR authorization.

2: Aircraft must operate clear of cloud and within sight of the ground at all times.

3: Helicopters should operate at such reduced airspeeds so as to give the pilot-in-command adequate opportunity to see other air traffic or obstructions in time to avoid a collision.

4: When the aircraft is not a helicopter and is being operated at night, ATC will only authorize special VFR where the authorization is for the purpose of allowing the aircraft to land at the destination aerodrome.

Figure 2.8 – Special VFR Weather Minima

	Flight Visibility (Ground when reported)	Distance from cloud
Aircraft other than Helicopter	1 mile	Clear of cloud
Helicopter	1/2 mile	

2.7.4 VFR Over-the-Top

A person may operate an aircraft VFR over-the-top (VFR OTT), provided certain conditions are met. Those conditions include weather minima, aircraft equipment and pilot qualifications. Pilots should indicate that the flight is VFR OTT during communications with ATS units. Deviations from the intended route of flight may be necessary when transiting CZs or TCAs. Pilots should take into consideration the additional fuel requirements this may cause.

CAR 602.116 specifies the weather minima for VFR OTT. A summary of the minima follows:

- (a) VFR OTT is allowed during the day only, and during the cruise portion of the flight only.
- (b) The aircraft must be operated at a vertical distance from cloud of at least 1 000 ft.
- (c) Where the aircraft is operated between two cloud layers, those layers must be at least 5 000 ft apart.
- (d) The flight visibility at the cruising altitude of the aircraft must be at least 5 mi.
- (e) The weather at the destination aerodrome must have a sky condition of scattered cloud or clear, and a ground visibility of 5 mi. or more, with no forecast of precipitation, fog, thunderstorms, or blowing snow, and these conditions must be forecast to exist
 - (i) in the case of an aerodrome forecast (TAF), for the period from 1 hr before to 2 hr after the ETA; and
 - (ii) in the case of an area forecast (GFA) because a TAF is not available, for the period from 1 hr before to 3 hr after the ETA.

CARs 605.14 and 605.15 outline the aircraft equipment requirements for VFR OTT. In part, the equipment requirements are the same as for VFR flight, with extra requirements for VFR OTT.

Pilot qualifications for VFR OTT flight are specified in CARs Part IV—*Personnel Licensing and Training*.

2.7.5 Transition Areas

Transition areas are established when it is considered advantageous or necessary to provide additional controlled airspace for the containment of IFR operations.

Transition areas are of defined dimensions, based at 700 ft AGL unless otherwise specified, and extend upwards to the base of overlying controlled airspace. The area provided around an aerodrome will normally be 15 NM radius of the aerodrome coordinates, but shall be of sufficient size to contain all of the aerodrome published instrument approach procedures. Even if described with an ASL floor, the base of a transition area shall not extend lower than 700 ft AGL.

2.7.6 Terminal Control Areas

Terminal control areas are established at high volume traffic airports to provide an IFR control service to arriving, departing and enroute aircraft. Aircraft operating in the TCA are subject to certain operating rules and equipment requirements. The TCA operating rules are established by the classification of the airspace within the TCA. These rules will be based on the level of ATC service that is appropriate for the number and type of aircraft using the airspace as well as the nature of the operations being conducted.

A TCA is similar to a control area extension except that:

- a TCA may extend up into the high level airspace;
- IFR traffic is normally controlled by a terminal control unit. The ACC will control a TCA during periods when a TCU is not in operation; and
- TCA airspace will normally be designed in a circular configuration, centred on the geographic coordinates of the primary aerodrome. The outer limit of the TCA should be at 45 NM radius from the aerodrome geographic coordinates based at 9 500 ft AGL, with an intermediate circle at 35 NM based at 2 200 ft AGL and an inner circle at 12 NM radius based at 1 200 ft AGL. Where an operational advantage may be gained, the area may be sectorized. For publication purposes the altitudes may be rounded to the nearest appropriate increment and published as heights ASL. The floor of a TCA shall not extend lower than 700 ft AGL.

A military terminal control area is the same as a TCA, except that special provisions prevail for military aircraft while operating within the MTCA. MTCAs may be designated at selected military aerodromes where the control service will be provided by a military TCU, or by ATC, through agreement with DND.

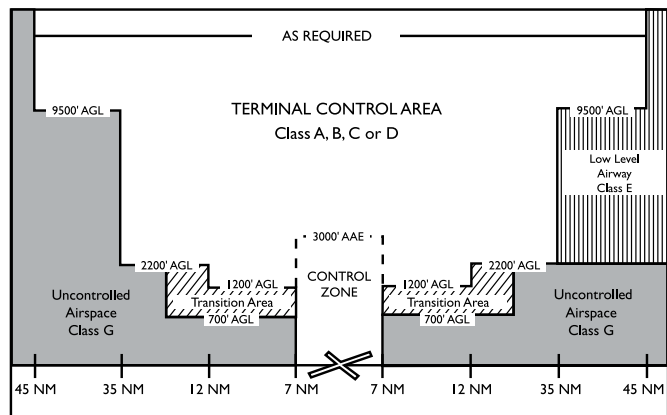

All low level controlled airspace above 12 500 feet ASL or at and above the MEA, whichever is higher, up to but not including 18 000 feet ASL will be Class B airspace.

Control zones and associated terminal control areas may also be classified as Class B airspace.

NOTES 1: No person shall operate an aircraft in Class B controlled airspace in VFR flight unless:

- (a) the aircraft is equipped with:
 - (i) radio communication equipment capable of two-way communication with the appropriate ATS facility, and
 - (ii) radio navigation equipment capable of using navigation facilities to enable the aircraft to be operated in accordance with the flight plan, and
 - (iii) a transponder and automatic pressure altitude reporting equipment;
- (b) a continuous listening watch is maintained by a flight crew member on a radio frequency assigned by ATC;
- (c) except as otherwise authorized by ATC, when the aircraft is over a reporting point a position report is transmitted to the appropriate unit or, when so directed by ATC, to an FSS; and
- (d) the aircraft is operated in VMC at all times.

2: A person operating an aircraft on a VFR flight in Class B airspace shall operate the aircraft in VMC at all times. When it becomes evident that flight in VMC will not be possible at the altitude or along the route specified, the pilot shall:

- (a) request an ATC clearance which will enable the aircraft to be operated in VMC to the filed destination, or to another aerodrome;
- (b) where the person is the holder of a valid instrument rating, request an IFR clearance for flight under the instrument flight rules; or
- (c) where the Class B airspace is a control zone, request an authorization for special VFR flight.

3: A person operating an aircraft in Class B controlled airspace in VFR flight who is unable to comply with the requirements of the preceding paragraphs shall ensure that:

- (a) the aircraft is operated in VMC at all times;
- (b) the aircraft leaves Class B controlled airspace:
 - (i) by the safest and shortest route, either exiting horizontally or descending, or
 - (ii) when that airspace is a control zone, by landing at the aerodrome on which the control zone is based, and
- (c) an ATC unit is informed as soon as possible of the actions taken pursuant to paragraph (b).

2.8 AIRSPACE CLASSIFICATION

Canadian Domestic Airspace is divided into seven classes, each identified by a single letter – A, B, C, D, E, F, or G. Flight within each class is governed by specific rules applicable to that class and are contained in CAR 601, *Division I, Airspace Structure, Classification and Use*.

The rules for operating within a particular portion of airspace depends on the classification of that airspace and not on the name by which it is commonly known. Thus, the rules for flight within a high level airway, a terminal control area or a control zone depend on the class of airspace within all or part of those areas. Weather minima are specified for controlled or uncontrolled airspace, not for each class of airspace.

2.8.1 Class A Airspace

Class A airspace is designated where an operational need exists to exclude VFR aircraft.

All operations must be conducted under Instrument Flight Rules and are subject to ATC clearances and instructions. ATC separation is provided to all aircraft.

All aircraft operating in Class A airspace must be equipped with a transponder and automatic pressure altitude reporting equipment.

Class A airspace will be designated from the base of all high-level controlled airspace, or from 700 ft AGL, whichever is higher, up to and including FL600.

2.8.2 Class B Airspace

Class B airspace is designated where an operational need exists to provide air traffic control service to IFR and to control VFR aircraft.

Operations may be conducted under IFR or VFR. All aircraft are subject to ATC clearances and instructions. ATC separation is provided to all aircraft.

2.8.3 Class C Airspace

Class C airspace is a controlled airspace within which both IFR and VFR flights are permitted, but VFR flights require a clearance from ATC to enter. ATC separation is provided between all aircraft operating under IFR and, as necessary to resolve possible conflicts, between VFR and IFR aircraft. Aircraft will be provided with traffic information. Conflict resolution will be provided, upon request, after VFR aircraft is provided with traffic information.

Traffic information is issued to advise pilots of known or observed air traffic which may be in proximity to their aircraft's position or intended route of flight warranting their attention. Conflict resolution is defined as the resolution of potential conflicts between IFR/VFR and VFR/VFR aircraft that are radar identified and in communication with ATC.

Airspace classified as Class C becomes Class E airspace when the appropriate ATC unit is not in operation.

Terminal control areas and associated control zones may be classified as Class C airspace.

A person operating an aircraft in VFR flight in Class C airspace shall ensure that:

- (a) the aircraft is equipped with
 - (i) radio communication equipment capable of two-way communication with the appropriate ATC unit, and
 - (ii) a transponder and automatic pressure altitude reporting equipment; and
- (b) a continuous listening watch is maintained by a flight crew member on a radio frequency assigned by ATC.

A person wishing to operate an aircraft that is not equipped with functioning communication and transponder equipment for VFR flight in Class C airspace may, during daylight hours and in VMC, enter Class C airspace provided that permission to enter and to operate within the airspace is obtained from ATC prior to the operation being conducted.

2.8.4 Class D Airspace

Class D airspace is a controlled airspace within which both IFR and VFR flights are permitted, but VFR flights must establish two-way communication with the appropriate ATC agency prior to entering the airspace. ATC separation is provided only to IFR aircraft. Aircraft will be provided with traffic information. Equipment and workload permitting, conflict resolution will be provided between VFR and IFR aircraft, and upon request between VFR aircraft.

Airspace classified as Class D becomes Class E airspace when the appropriate ATC unit is not in operation.

A terminal control area and associated control zone could be classified as Class D airspace.

A person operating an aircraft in VFR flight in Class D airspace shall ensure that:

- (a) the aircraft is equipped with
 - (i) radio communication equipment capable of two-way communication with the appropriate ATC unit, and
 - (ii) where the Class D airspace is specified as Transponder Airspace (see RAC 1.9.2), a transponder and automatic pressure altitude reporting equipment; and
- (b) a continuous listening watch is maintained by a flight crew member on a radio frequency assigned by ATC.

A person operating an aircraft in VFR flight that is not equipped with the required radio communication equipment may, during daylight hours in VMC, enter Class D airspace provided that permission to enter is obtained from the appropriate ATC unit prior to operating within the airspace.

2.8.5 Class E Airspace

Class E airspace is designated where an operational need exists for controlled airspace but does not meet the requirements for Class A, B, C, or D.

Operations may be conducted under IFR or VFR. ATC separation is provided only to aircraft operating under IFR. There are no special requirements for VFR.

Aircraft are required to be equipped with a transponder and automatic pressure altitude equipment to operate in Class E airspace that is specified as transponder airspace (see RAC 1.9.2).

Low level airways, control area extensions, transition areas, or control zones established without an operating control tower may be classified as Class E airspace.

2.8.6 Class F Airspace

Class F airspace is airspace of defined dimensions within which activities must be confined because of their nature, and within which limitations may be imposed upon aircraft operations that are not a part of those activities.

Special-use airspace may be classified as Class F advisory or as Class F restricted, and can be controlled airspace, uncontrolled airspace, or a combination of both. An advisory area, for example, may have the floor in uncontrolled airspace and the ceiling in controlled airspace. The significance, in this instance, is that the weather minima would be different in the controlled and uncontrolled portions.

Unless otherwise specified, the rules for the appropriate airspace apply in areas of Class F airspace, no matter if they are active or inactive.

Class F airspace shall be designated in the DAH (TP 1820E) in accordance with the airspace regulations, and shall be published on the appropriate aeronautical charts.

Charting of Class F Airspace

All designated Class F restricted and advisory airspace is published on HI or LO charts, as applicable, and on VFR aeronautical charts.

Each restricted and advisory area within Canada has been assigned an identification code group, which consists of the four following parts:

- Part (a) the nationality letters CY;
- Part (b) the letter R for restricted area (the letter D for danger area if the restricted area is established over international waters) or the letter A for advisory area;
- Part (c) a three-digit number that will identify the area. This number will indicate the Canadian region within which the area lies as follows:

- 101 to 199 – British Columbia
- 201 to 299 – Alberta
- 301 to 399 – Saskatchewan
- 401 to 499 – Manitoba
- 501 to 599 – Ontario
- 601 to 699 – Quebec
- 701 to 799 – New Brunswick, Nova Scotia, Prince Edward Island, Newfoundland
- 801 to 899 – Yukon Territory
- 901 to 999 – Northwest Territories and Nunavut (including the Arctic Islands)

- Part (d) in the case of advisory areas, the letter A, F, H, M, P, S or T in parentheses after the three-digit number that will indicate the type of activity within the area as follows:

- A – acrobatic
- F – aircraft test
- H – hang gliding
- M – military operations
- P – parachuting
- S – soaring
- T – training

Example: The identification code group CYA113(A) means the following:

- CY – indicates Canada
- A – indicates advisory
- 113 – indicates the number of an area in British Columbia
- (A) – indicates acrobatic activity takes place within the area.

All altitudes will be inclusive, unless otherwise indicated (e.g. 5 000 to 10 000 ft). To indicate when either the bottom or upper altitude is not included, the words below and above will be placed before the appropriate altitude (e.g. above 5 000 to 10 000 ft, or 5 000 to below 10 000 ft).

Danger Area (International Waters)

Any restricted area that may be established over international waters, but controlled by Canadian ATC, will be indicated as a “danger area” in accordance with ICAO requirements. ICAO defines a danger area as airspace of defined dimensions within which activities dangerous to the flight of aircraft may exist at specified times.

Advisory Airspace

Airspace may be classified as Class F advisory airspace if it is airspace within which an activity occurs that, for flight safety purposes, non-participating pilots should be aware of, such as training, parachuting, hang gliding, military operations, etc.

There are no specific restrictions that apply to the use of advisory airspace. VFR aircraft are, however, encouraged to avoid flight in advisory airspace unless participating in the activity taking place therein. If necessary, pilots of non-participating flights may enter advisory areas at their own discretion; however, due to the nature of the aerial activity, extra vigilance is recommended. Pilots of participating aircraft, as well as pilots flying through the area, are equally responsible for collision avoidance.

ATC will not clear IFR aircraft through Class F airspace, except if:

- (a) the pilot states that permission has been obtained from the user agency to enter the airspace;
- (b) the aircraft is operating on an altitude reservation approval (ALTRV APVL); or
- (c) the aircraft has been cleared for a contact or visual approach.

IFR aircraft shall be provided 500 ft vertical separation from an active Class F advisory airspace, unless wake turbulence minima is applicable, in which case 1 000 ft vertical separation shall be applied.

Pilots intending to fly in Class F advisory airspace are encouraged to monitor an appropriate frequency, to broadcast their intentions when entering and leaving the area, and to communicate, as necessary, with other users to ensure flight safety in the airspace. In a Class F advisory uncontrolled airspace area, 126.7 MHz would be an appropriate frequency.

NOTE: Military operations in Class F airspace may be UHF only.

Restricted Airspace

A restricted area is airspace of defined dimensions above the land areas or territorial waters within which the flight of aircraft is restricted in accordance with certain specified conditions. Restricted airspace is designated for safety purposes when the level or type of aerial activity, the surface activity, or the protection of a ground installation requires the application of restrictions within that airspace.

No person may conduct aerial activities within active Class F restricted airspace, unless permission has been obtained from the user agency. In some instances, the user agency may delegate the appropriate controlling agency the authority to approve access. IFR flights will not be cleared through active restricted areas, unless the pilot states that permission has been obtained.

The user agency is the civil or military agency or organization responsible for the activity for which the Class F airspace has been provided. It has the jurisdiction to authorize access to the airspace when it is classified restricted. The user agency must be identified for Class F restricted airspace, and where possible, it should be identified for Class F advisory airspace.

Special-use areas will be designated restricted areas and identified by the prefix CYR, followed by a three-digit number that identifies the location of the area.

Elements of existing airspace structure may also be designated as restricted airspace if it would facilitate the efficient flow of air traffic.

There are two additional methods of restricting airspace.

- (a) CAR 601.16—*Issuance of NOTAM for Forest Fire Aircraft Operating Restrictions*, is designed to allow the Minister to issue a NOTAM to restrict flight around and over forest fire areas or areas where forest fire control operations are being conducted. The provisions of this section can be invoked quickly via NOTAM by Transport Canada (see RAC 2.9.2).
- (b) Section 5.1 of the *Aeronautics Act* allows the Minister to restrict flight in any airspace, for any purpose, by NOTAM. This authority is delegated by the Minister to cover specific situations, such as well fires, disaster areas, etc., for the purpose of ensuring safety of flight for air operations in support of the occurrence.

It should be noted that airspace that is restricted by invoking CAR 601.16 or section 5.1 of the *Aeronautics Act* is not Class F restricted airspace; the airspace has not been classified in accordance with the airspace regulations. This distinction is important to those who are charged with the responsibility for restricting airspace, since their actions are governed by the provisions of the *Statutory Instruments Act*.

Joint-Use Airspace

Joint-use airspace is Class F airspace within which operations may be authorized by the controlling agency when it is not being utilized by the user agency.

Class F restricted airspace should be available for use by non-participating aircraft when all or part of the airspace is not required for its designated purpose.

To ensure maximum utilization of restricted airspace, user agencies should be encouraged to make restricted airspace available for the conduct of operations or training of other agencies or commands on a joint-use basis.

The ATC agency may be designated to provide air traffic control or information service within the Class F airspace involved. A controlling agency will normally be assigned when there is joint use of the airspace.

NOTAM

It is permissible to designate Class F restricted airspace by NOTAM, if the following prerequisites are met:

- (a) the area of restricted airspace is required for a specified period of time of relative short duration (i.e. several hours or days); and
- (b) the appropriate NOTAM is issued at least 24 hr in advance of the area's activation.

2.8.7 Class G Airspace

Class G airspace is airspace that has not been designated Class A, B, C, D, E or F, and within which ATC has neither the authority nor the responsibility to exercise control over air traffic.

However, ATS units do provide flight information and alerting services. The alerting service will automatically alert SAR authorities once an aircraft becomes overdue, which is normally determined from data contained in the flight plan or flight itinerary.

In effect, Class G is all uncontrolled domestic airspace.

Low-level air routes are contained within Class G airspace. They are basically the same as a low-level airway, except that they extend upwards from the surface of the earth and are not controlled. The lateral dimensions are identical to those of a low-level airway (see RAC 2.7.1).

2.9 OTHER AIRSPACE DIVISIONS

Additional airspace divisions have been designated in order to increase safety or make allowances for the remote or mountainous regions within Canada. These divisions (or regions) are: altimeter setting region, standard pressure region and designated mountainous region.

2.9.1 Altitude Reservation

An altitude reservation is airspace of defined dimensions within controlled airspace reserved for the use of a civil or military agency during a specified period. An altitude reservation may be confined to a fixed area (stationary) or moving in relation to the aircraft that operates within it (moving). Information on the description of each altitude reservation is normally published by NOTAM. Civil altitude reservations are normally for a single aircraft, while those for military use are normally for more than one aircraft.

Pilots should plan to avoid known altitude reservations. ATC will not clear an unauthorized flight into an active reservation. IFR and CVFR flights are provided with standard separation from altitude reservations.

2.9.2 Temporary Flight Restrictions—Forest Fires

In the interest of safe and efficient fire fighting operations, the Minister may issue a NOTAM restricting flights over a forest fire area to those operating at the request of the appropriate fire control authority (i.e. water bombers), or to those with written permission from the Minister.

The NOTAM would identify the following:

- (a) the location and dimensions of the forest fire area;
- (b) any airspace in which forest fire control operations are being conducted; and
- (c) the length of time during which flights are restricted in the airspace.

No person shall operate an aircraft in the airspace below 3 000 ft AGL within 5 NM of the limits of a forest fire area, or as described in a NOTAM (CARs 601.15, 601.16, and 601.17).

2.9.3 Flight Operations Over or in the Vicinity of Nuclear Power Plants

Pilots are reminded that overflights of nuclear power plants shall be carried out in accordance with the provisions of CAR 602.14(2) (see RAC 5.4).

Pilots should also be aware that loitering in the vicinity of, or circling, nuclear power plants should be avoided. Aircraft observed operating in this manner in the vicinity of nuclear power plants could be intercepted by government or law-enforcement aircraft, and escorted away from the facility to the nearest suitable aerodrome to be interviewed by police authorities.

2.10 ALTIMETER SETTING REGION

The altimeter setting region is an airspace of defined dimensions below 18 000 feet ASL (see CAR 602.35 and Figure 2.9) within which the following altimeter setting procedures apply:

Departure – Prior to takeoff, the pilot shall set the aircraft altimeter to the current altimeter setting of that aerodrome or, if that altimeter setting is not available, to the elevation of the aerodrome.

En route – During flight the altimeter shall be set to the current altimeter setting of the nearest station along the route of flight or, where such stations are separated by more than 150 NM, the nearest station to the route of flight.

Arrival – When approaching the aerodrome of intended landing the altimeter shall be set to the current aerodrome altimeter setting, if available.

2.11 STANDARD PRESSURE REGION

The standard pressure region includes all airspace over Canada at or above 18 000 feet ASL (the high level airspace), and all low level airspace that is outside of the lateral limit of the altimeter setting region (see Figure 2.9 and CAR 602.36). Within the standard pressure region the following flight procedures apply;

General – Except as otherwise indicated below, no person shall operate an aircraft within the standard pressure region unless the aircraft altimeter is set to standard pressure, which is 29.92 inches of mercury or 1013.2 mbs. (See *Note*).

Departure – Prior to takeoff the pilot shall set the aircraft altimeter to the current altimeter setting of that aerodrome or, if the altimeter setting is not available, to the elevation of that aerodrome. Immediately prior to reaching the flight level at which flight is to be conducted, the altimeter shall be set to standard pressure (29.92 inches of mercury or 1013.2 mbs). If the planned cruising flight level is above FL180, resetting the altimeter to 29.92 inches of mercury or 1013.2 mbs at 18 000 feet ASL is acceptable and meets the requirement of CAR 602.36.

Arrival – Prior to commencing descent with the intention to land, the altimeter shall be set to the current altimeter setting of the aerodrome of intended landing, if available. However, if a holding procedure is conducted, the altimeter shall not be set to the current aerodrome altimeter setting until immediately prior to descending below the lowest flight level at which the holding procedure is conducted. Pilots of aircraft descending from cruising flight levels above FL180 may reset altimeters to the current altimeter setting of the aerodrome of intended landing when approaching FL180 provided no holding or cruise level flight below FL180 is to be made or anticipated.

Transition – CAR 602.37 – *Altimeter Setting and Operating Procedures in Transition between Regions*, specifies that except as otherwise authorized by ATC, aircraft progressing from one region to another shall make the change in the altimeter setting while within the standard pressure region prior to entering, or after leaving, the altimeter setting region. If the transition is to be made into the altimeter setting region while in level cruising flight, the pilot should obtain the current altimeter setting from the nearest station along the route of flight as far as practical before reaching the point at which the transition is to be made. When climbing from the altimeter setting region into the standard pressure region, pilots shall set their altimeters to standard pressure (29.92 inches of mercury or 1013.2 mbs) immediately after entering the standard pressure region. When descending into the altimeter setting region, pilots shall set their altimeters to the appropriate station altimeter setting immediately prior to descending into the altimeter setting region. Normally, the pilot will receive the appropriate altimeter setting as part of the ATC clearance prior to descent. If it is not incorporated in the clearance, it should be requested by the pilot.

NOTE: When an aircraft is operating in the standard pressure region with standard pressure set on the altimeter subscale, the term “flight level” is used in lieu of “altitude” to express its height. Flight level is always expressed in hundreds of feet. For example FL250 represents an altimeter indication of 25 000 feet; FL50, an indication of 5 000 feet.

Figure 2.9 – Altimeter Setting and Standard Pressure Regions

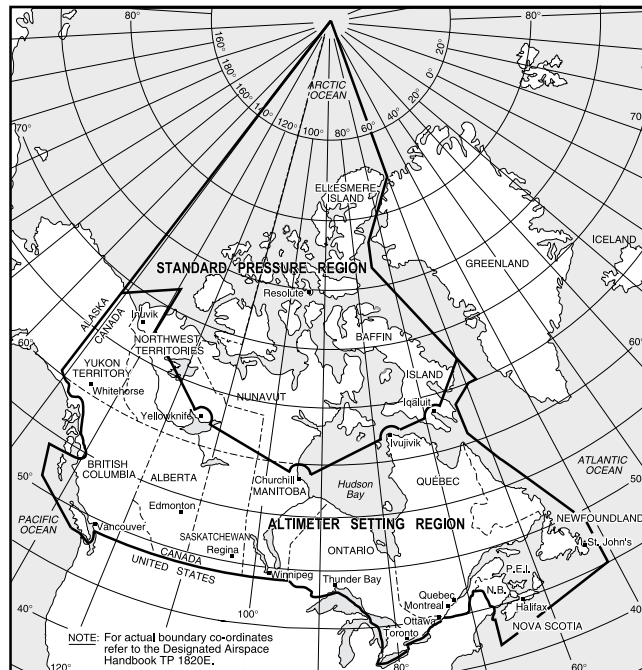

2.12 MOUNTAINOUS REGIONS

Designated mountainous regions are areas of defined lateral dimensions, specified in the *Designated Airspace Handbook*, above which special rules concerning minimum IFR altitudes to ensure obstacle clearance (CAR 602.124) apply.

An aircraft, when operated in accordance with IFR within designated mountainous regions, but outside of areas for which minimum altitudes for IFR operations have been established (including minimum radar vectoring altitudes, MOCAs, transition altitudes, 100NM safe altitudes, MSAs and AMAs), shall be flown at an altitude of at least 2000 feet above the highest obstacle within 5NM of the aircraft in flight when in areas 1 and 5, and at least 1500 feet above the highest obstacle within 5NM when in areas 2, 3 and 4. (See Figure 2.10.)

As minimum enroute IFR altitudes have been established for designated airways and air routes, such minimum altitudes shall be applied when flying in accordance with IFR along airways or air routes within designated mountainous regions, except that aircraft should be operated at an altitude which is at least 1000 feet higher than the minimum enroute IFR altitude, when there are large variations in temperature and/or pressure. (See RAC 8.6)

RAC

Figure 2.10 – Designated Mountainous Regions in Canada

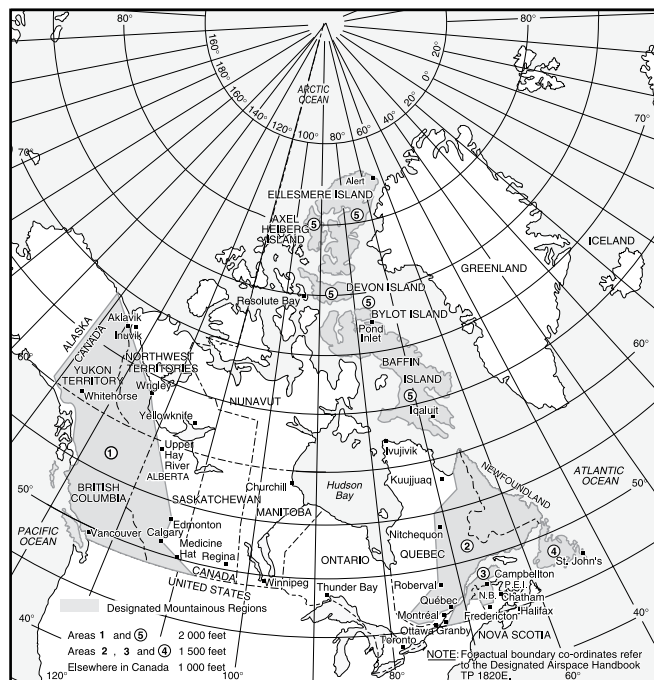

2.13 EMERGENCY COMMUNICATIONS AND SECURITY

The rules for operating within the Air Defence Identification Zone (ADIZ) are specified in CAR 602.145 – ADIZ, and are repeated in RAC 3.9.

Figure 2.11 – Air Defence Identification Zone

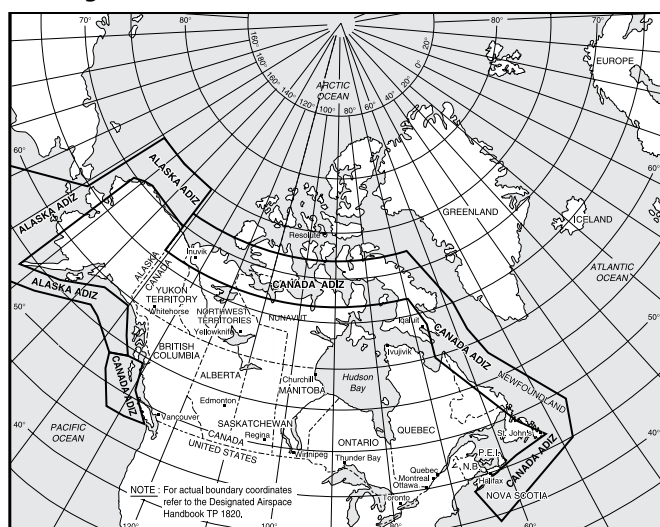

3.0 FLIGHT PLANNING

3.1 GENERAL

The flight planning requirements contained in this Section are based, in part, on the CAR, Part VI, General Operating and Flight Rules.

The pilot-in-command of an aircraft shall, before commencing a flight, be familiar with the available information that is appropriate to the intended flight (CAR 602.71).

The pilot-in-command of an aircraft shall, before commencing a flight, be familiar with the available weather information that is appropriate to the intended flight (CAR 602.72). Pilots should refer to the MET Section for aviation weather information.

3.2 PILOT BRIEFING SERVICE

The pilot briefing service is provided by FICs to assist pilots at the pre-flight planning stage and for information updates while en route. Pilot requests for initial briefings while airborne are not encouraged because this practice leads to frequency congestion.

The telephone numbers of NAV CANADA FICs are found in the General and Aerodrome/Facility Directory sections of the CFS or WAS. Long distance phone calls can be made to an FIC toll-free at 1-866-WXBRIEF (1-866-992-7433). A call to this number is routed to the FIC that serves the area from which the call originates. A call to 1-866-GOMÉTÉO (1-866-466-3836) is routed to the Québec FIC for the provision of bilingual service. A specific FIC may be contacted at the number shown in the CFS or WAS, General section, Flight Planning (FLT PLN) sub-section. Collect calls from pilots are accepted at all FICs.

When requesting a briefing, identify yourself as a pilot; provide the aircraft identification and the following:

- a) type of flight (VFR, IFR, CVFR, composite) planned;
- b) type of aircraft;
- c) aerodrome of departure and estimated time of departure (ETD);
- d) destination aerodrome and estimated elapsed time (EET);
- e) planned cruising level(s) or altitude(s);
- f) route to be flown and estimated times of arrival at, and departure from, any intermediate aerodrome(s);
- g) alternate aerodrome, if appropriate;

- h) type of meteorological information requested, i.e. whether a briefing or consultation; and
- i) information already on hand, if any.

The flight service specialist requires this information to tailor the briefing to the planned flight and the needs of the pilot. The flight service specialist may omit information normally provided in a briefing if the pilot has indicated having the data on hand or requested the briefing be limited to specific information. The flight service specialist will terminate the briefing by soliciting flight plan information not already obtained at the beginning of the briefing and PIREP, if appropriate. (See RAC 3.16 for details concerning flight plan content).

3.3 AERONAUTICAL INFORMATION

Aeronautical information (NOTAM, RSC, CRFI, flow control, etc.) is available at ATS units and at certain operations offices. Aeronautical information is routinely provided by FICs during a pilot briefing and upon request in FISE. Telephone numbers and RCO frequencies for all FICs are listed in the CFS and the WAS.

Canadian domestic NOTAMs are disseminated via AFTN and stored electronically on a NOTAM file concept. There are three categories of NOTAM files: National NOTAMs, FIR NOTAMs and aerodrome NOTAMs. Before commencing a flight, pilots must ensure that each NOTAM file category has been reviewed, in order to be familiar with all NOTAMs appropriate to the intended flight (see MAP 5.0 for details).

Canadian domestic and international NOTAMs have different distribution lists. Only Canadian domestic NOTAMs that concern international flights are sent out internationally (in the ICAO format). All pertinent Canadian domestic NOTAM files must be consulted to obtain NOTAM information for flights within Canada (see MAP 5.2 for details).

3.4 DUATS

Flight plans and flight itineraries may also be filed via DUATS.

3.5 WEIGHT AND BALANCE CONTROL

3.5.1 Definitions

The following definitions and abbreviations are used in weight and balance control:

- (a) *Actual Weight*: With respect to weight and balance control, weight obtained by actually weighing all passengers, personal clothing and carry-on baggage just before boarding the flight. When weighing scales are not available or serviceable, the following weights may be used instead of the actual weight of each passenger:
 - (i) *Volunteered Weight*: Weight obtained by asking the passenger for his or her weight, adding 4.5 kg (10 lbs) to the disclosed value, and using the result as the passenger's weight; or
 - (ii) *Estimated Weight*: Weight obtained by making a reasonable estimate of the passenger's weight when actual weight or volunteered weight is not provided.

NOTE: In all cases, the allowances for passenger clothing and carry-on baggage should be included in the weight of the passenger.

- (b) *Air Operator Segmented Weight*: Approved segmented weights derived by the air operator from statistically computed data in accordance with procedures that are acceptable to the Minister. These weights may be used instead of the segmented weights published by TCCA and are applicable only to that air operator. Furthermore, they may be used only in the circumstances consistent with those under which the survey was conducted.
- (c) *Air Operator Standard Weight*: Approved standard weights derived by the air operator from statistically computed data in accordance with procedures that are acceptable to the Minister. These may be used instead of the standard weights published by TCCA and are applicable only to that air operator. Furthermore, they may be used only in the circumstances consistent with those under which the survey was conducted.
- (d) *Basic Empty Weight*: Basic weight of the aircraft as determined in accordance with the Aircraft Flight Manual (AFM).
- (e) *Carry-On Baggage*: Baggage that a passenger carries on board; its weight should be included in the weight of each passenger. Based on the particular aircraft stowage limitations, the operator may limit the number, size, shape and weight of the carry-on baggage so it can be stowed under the passenger's seat or in the storage compartment. Otherwise, the standard allowance is 5.9 kg (13 lbs) of carry-on baggage per passenger, a figure that remains the same throughout the year.

NOTE: The only circumstance under which the weight of the carry-on baggage may not be added to the weight of each passenger is when no carry-on baggage is permitted on the flight.

- (f) *Checked Baggage*: Bags that are individually checked in, weighed and placed in the cargo compartment of the aircraft. This includes bags that are too large to be placed in the cabin of the aircraft and bags that are required to be carried in the cargo compartment by regulation, security program, or company policy. For bags checked plane-side, see the definition for plane-side loaded bags.
- (g) *Empty Weight*: Total weight of the following parts or contents, which are part of, or carried on board, the aircraft:
- the airframe, including the rotor of a helicopter or gyroplane;
 - the power plant;
 - the fixed ballast;
 - the unusable fuel;
 - the maximum amount of normal operating fluids, including oil, power-plant coolant, hydraulic fluid, de-icing fluid and anti-icing fluid, but not including potable water, lavatory pre-charge fluid or fluid intended for injection into the engines; and
 - all of the installed equipment.
- (h) *Female to Male Mix Ratio*: Ratio of female to male passengers who are actually carried on board a flight, often expressed as a percentage, and that is independent of the aircraft certificated seating capacity.
- (i) *Large Aeroplane*: Aeroplane with an MCTOW of over 5 700 kg (12 566 lbs).
- (j) *Maximum Certificated Take-Off Weight (MCTOW)*: Weight identified as such in the type certificate of an aircraft.
- (k) *Maximum Permissible Take-Off Weight or Maximum Take-Off Weight (MTOW)*: Maximum take-off weight for an aircraft as authorized by the aircraft's state of registry or as provided for in the aircraft type certificate.
- (l) *On-Board Weight and Balance System*: System that weighs the aircraft and its payload, then calculates the CG using equipment on board the aircraft.
- (m) *Operational Empty Weight*: Actual weight of the aircraft before loading for dispatch, consisting of the aircraft basic empty weight. The operational empty weight may include removable equipment, flight crew members and crew members (including baggage), oil, unusable fuel, as well as emergency equipment, and should be defined by the air operator.
- (n) *Operations Personnel*: Personnel whose duties and responsibilities involve maintenance, loading, unloading, dispatching, servicing, weight and balance, passenger escort, scheduling, de-icing, or working on the ramp. This also includes members of the flight crew and cabin crew, as well as anyone involved in the aircraft's operation.
- (o) *Passenger*: Person, other than a crew member, who is carried on board an aircraft and, for weight and balance control, is categorized as:
- Adult: Person, regardless of sex, who is aged 12 years or older and who may be subcategorized as male or female;
 - Child: Person who is between 2 to less than 12 years of age; or
 - Infant: Person who is less than 2 years of age.
- (p) *Personal Clothing*: Weight of personal clothing that a passenger carries on board the aircraft, which is standardized as 3.6 kg (8 lbs) for summer and 6.4 kg (14 lbs) for winter, and that must be added to the passenger's weight for the purpose of weight and balance calculation.
- (q) *Plane-Side Loaded Bag*: Any bag or item that is placed at the door or steps of an aircraft because it cannot be accommodated as carry-on baggage and that is subsequently placed in the aircraft cargo compartment or cargo bin.
- (r) *Segmented Weight*: Statistically derived average passenger weight modified by appropriate standard deviations to increase the likelihood that the actual weight will not exceed the average weight. Segmented weights are further modified to cater for variations in aircraft passenger seating capacity and the distribution of passengers according to sex. They are designed to be representative of the average weight of adult passengers, including personal clothing and carry-on baggage allowances, and are intended for use in weight and balance calculation of aircraft. In a Canadian context, segmented weights are applicable for aircraft that are certificated for 5 to 11 (inclusive) passenger seats.
- (s) *Small Aircraft*: Aeroplane with a maximum permissible take-off weight of 5 700 kg (12 566 lbs) or less, or a helicopter with a maximum permissible take-off weight of 2 730 kg (6 018 lbs) or less.
- (t) *Standard Weight*: Weights published by TCCA as standard average passenger weights, including personal clothing and carry-on baggage allowances, for use in weight and balance calculations that do not involve actual weighing.

3.5.2 Weight Control

Pilots must recognize the effect of weight and balance on the performance and handling of aircraft, particularly in combination with performance-reducing factors, such as contaminated runways, aircraft icing, degraded engine performance, severe or uncoordinated manoeuvres, turbulence, high ambient temperatures and emergency situations.

It is mandatory to calculate weight and balance accurately for every flight and ensure that they are within the aircraft's permissible limits in order to comply with the aircraft airworthiness certificate and conform to the regulations.

Before the aircraft takes off, it is equally important that the pilot-in-command (PIC) of the aircraft ensures that the load carried by the aircraft is of an appropriate weight and distributed and secured in such a way that it may be carried safely on the intended flight. If weight and centre-of-gravity (balance) limitations are not observed, the pilot is failing to comply with a legal condition for the operation of the aircraft, which therefore nullifies its airworthiness certificate.

It must be recognized that with many four- and six-seat aircraft, it is not possible to fill all the seats, use the maximum baggage allowance, fill all the fuel tanks and still remain within the approved weight and centre-of-gravity limitations.

Estimating baggage weight can result in gross inaccuracies. If it is possible that the aircraft is operating close to its maximum take-off weight, the baggage must be weighed. Even a pocket-sized spring balance can be used as a handy standby if weighing scales are not available. This reduces the risk involved in guesswork. Note that on some aircraft, restrictions are placed on rear-seat occupancy if the maximum baggage allowance is used. When the aircraft is carrying freight, check for discrepancies with the declared weight. Ensure the weight per unit area limitation on the baggage compartment floor is not exceeded. It is critical to ensure that the baggage/freight is properly stowed, cannot move during flight, and does not obstruct exits or access to emergency equipment.

If the aircraft is suspected to be operating anywhere close to its maximum weight, passengers must be weighed. The risk of embarrassment is not a reason for risking safety or crossing weight limits. It is important to remember that a passenger's weight is not his or her stripped weight, but must include personal clothing and carry-on baggage allowances.

Fuel is supplied in pounds (lbs), kilograms (kg), litres (l) or gallons (gal). Pilots should note which unit is being used and calculate the fuel weight accordingly. Incorrect conversion could be hazardous in terms of endurance and fuel weight estimation.

3.5.3 Balance

Balance refers to the location of the centre of gravity (CG) along the longitudinal axis of the aircraft. There are forward and aft limits established during certification flight testing; they are the maximum CG positions at which the longitudinal stability requirements can be met. If an aircraft is being operated outside these limits, its handling is either unsatisfactory or has not been investigated. The limits for each aircraft are contained in the Pilot Operating Handbook and the Aircraft Flight Manual (AFM). The aircraft must not be flown outside these limits.

In many aircraft, there is significant CG movement as fuel is being consumed. Pilots should familiarize themselves with the CG movement associated with fuel consumption in their aircraft.

3.5.4 Operational Requirements

It is the responsibility of the PIC of the aircraft to ensure that the weight and balance report of the flight accurately represents the actual load and that the actual load does not exceed the maximum allowable weight limits specified in the AFM for any phase of the flight.

The report may be prepared by the crew or another qualified person authorized by the company or the operator of the aircraft.

Companies and operators may establish specific procedures with respect to preparing and retaining weight and balance documentation in order to meet regulatory requirements and standards, as applicable.

3.5.5 Computerized Systems

When a company or operator generates load data from a computerized weight and balance system, the integrity of the output data must be checked at regular intervals (preferably not greater than 6 months). The length of the intervals must be specified in the company operations manual.

There must be a means in place to identify the person inputting the data for the preparation of every load manifest. Moreover, the identity of that person must be verified and authenticated by the system and retained as required.

3.5.6 Segmented Weights

In practice, it was found that the use of standard passenger weights, regardless of aircraft size, increases the probability of overloading the aircraft when its passenger-carrying capacity decreases, and vice versa. For example, when the standard passenger weight is used for an aircraft certificated for 12 passengers, like the Twin Otter, the statistical probability of overloading the aircraft is as high as 25%, whereas when used for large passenger aircraft, like the Boeing 747, this probability diminishes to 0.0014%.

Furthermore, a single weight could not account for the weight differences between men and women and cater for variations in aircraft seating capacity. To minimize the probability of overloading the aircraft, an alternative to standard passenger weights, called segmented weights, was implemented. It is based on the seating capacity of the aircraft and accounts for weight differences between men and women. In order to obtain more accurate results, two tables were designed, one for summer and one for winter, to cater for seasonal variations.

When using segmented weights, a person can be 95% confident that the actual total weight of passengers will not exceed the total weight of passengers obtained by using segmented weights for the given number of passengers on board.

3.5.6.1 Derivation of Segmented Weights

A specific methodology was used to calculate the precise values published in the segmented weight tables. First, TCCA updated the average weight of Canadian males and females aged 12 and over based on a study entitled the Canadian Community Health Survey (CCHS), Cycle 2.1 (2003), which obtained large-scale weight data by surveying some 130 000 Canadians through interviews. Next, standard deviations of 16.8 kg (37 lbs) for males and 14.6 kg (32.2 lbs) for females were applied to obtain a revised average weight for each sex. These weights were modified again to cater for specific seating capacity ranges of the aircraft so as to be representative of the highest average weight amongst all sample sizes for that range. These values were further revised to cater for the various female to male passengers mix ratios. A constant value of 5.9 kg (13 lbs) for carry-on baggage was then added to obtain the average weight of a passenger, regardless of sex. Finally, two tables were developed to cater for seasonal variations in personal clothing—one for summer, which included 3.6 kg (8 lbs) for summer clothing, and the other for winter, which included 6.4 kg (14 lbs) for winter clothing. These tables are reproduced below (see segmented weight tables).

3.5.7 Computation of Passenger and Baggage Weights

- (a) The following methods are used to calculate the weight of passengers and baggage. In all cases, the allowances for personal clothing and carry-on baggage are included in the passenger's weight. Checked bags are individually weighed, and their weight is included when calculating the aircraft passenger and baggage load.
- (i) **Actual Weights:** By actually weighing all passengers, personal clothing and carry-on baggage. In such cases, standard allowances for personal clothing and carry-on baggage should not be used;
 - (ii) **Standard Weights:** By using standard weights, which could be published by TCCA or established by air operators; or
 - (iii) **Segmented Weights:** By using segmented weights, which could be published by TCCA or established by air operators.

NOTE: For aircraft with a passenger seating capacity of less than 5, the use of actual weights provides the greatest accuracy in calculating the weight and balance of the aircraft. The use of standard or segmented passenger weights is not recommended.

(b) By Actual Weights:

- (i) In determining the actual weight by weighing, an air operator must ensure that personal clothing and carry-on baggage are also actually weighed. Weighing should be conducted just before boarding (to avoid the chances of the passenger acquiring additional load just before boarding the aircraft).
- (ii) When a passenger refuses to be weighed, the air operator should ask the passenger to volunteer their weight (volunteered weight); if they refuse, the air operator should estimate their weight (estimated weight), ensuring in both cases that the allowances for personal clothing and carry-on baggage are included in the passenger's weight.
- (iii) Personnel boarding passengers based on volunteered weights or estimated weights should be able to assess the validity of the disclosed weight or estimate passengers' weight with a reasonable degree of accuracy; they should also take great care to avoid gross inaccuracies. Due diligence should be exercised to ensure that the passenger weights used to calculate the passenger and baggage load accurately reflect the actual weight to be carried on any given flight.

(c) By Standard Weights:

- (i) The weight of each passenger is calculated using standard weights published by TCCA or established by the air operator. In such cases, a standard allowance for personal clothing and carry-on baggage is included in the weight of each passenger. The standard weights are reproduced in the tables below (Table 1 – Standard Weights of Passengers Aged 12 Years or Older and Table 4 – Standard Weights of Children and Infants).

(d) By Segmented Weights:

- (i) Segmented weights should be used only when actual weights are not available or cannot be implemented; they are not applicable for aircraft certificated for 12 or more passenger seats. Subpart 703 prohibits air operators from using standard weights. Instead, they are recommended to use either actual weights or the segmented weights that are published by TCCA or established by the air operator.
- (ii) In order to use these tables, an air operator must follow these steps:
 - Step 1: Select the applicable summer or winter table.
 - Step 2: Select the row that is applicable to the maximum certificated passenger seating capacity range of the aircraft (not the number of passengers on board the flight).
 - Step 3: Select the column that represents the mix ratio of female to male passengers in percentage (may be interpolated to derive a meaningful female to male passengers mix ratio).

Step 4: Determine the applicable weight value, published or interpolated, for each passenger aged 12 or over. The cell at the intersection of the row that represents the maximum certificated passenger seating capacity range and the column that represents the passenger mix ratio, either published or interpolated, should contain the weight value to be used.

Step 5: Multiply the weight value obtained in Step 4 by the number of passengers aged 12 or older on board (not the certificated seating capacity), regardless of sex, to calculate the total weight of adult passengers (including personal clothing and carry-on baggage).

NOTE: Actual weights should be used on any flight identified as carrying a significant number of passengers whose weight or number of carry-on bags are deemed to be in excess of those specified in the segmented weights published by TCCA or established by the air operator.

- (e) When Carry-On Baggage Weight Is Not Included: The only circumstance under which the weight of the carry-on baggage may not be included in the actual weight of each passenger is in the case of flights on which passenger carry-on baggage is not permitted.
- (f) Weight of Children and Infants:
 - (i) Infants should be weighed with the accompanying adult. When an infant's weight is over 10% of the adult passenger's weight, the infant's weight should be included separately at the rate of 13.6 kg (30 lbs) per infant.
 - (ii) Infants occupying separate seats should be treated as children for the purpose of weight and balance calculation, and their weight should be included at the standard rate per child.
 - (iii) Each child should be weighed, or their weight should be included at the standard rate.
 - (iv) Standard weights of children and infants are indicated in Table 4 below.

TABLE 1 – STANDARD WEIGHTS OF PASSENGERS AGED 12 YEARS OR OLDER

(NOTE: These average weights are obtained from a Statistics Canada survey entitled Canadian Community Health Survey - Cycle 2.1, 2003.)

Summer		Winter
200 lbs or 90.7 kg	MALES (12 yrs up)	206 lbs or 93.4 kg
165 lbs or 74.8 kg	FEMALES (12 yrs up)	171 lbs or 77.5 kg

TABLE 2 – SEGMENTED WEIGHTS OF PASSENGERS AGED 12 YEARS OR OLDER
(IN POUNDS; SUMMER)

Maximum Certificated Passenger Seating Capacity	Ratio of Male (M) to Female (F) Passengers (in Percentages)											
	0M/100F	10M/90F	20M/80F	30M/70F	40M/60F	50M/50F	60M/40F	70M/30F	80M/20F	90M/10F	100M/0F	
1 to 4	Use Actual Weights, Volunteered Weights or Estimated Weights											
5	196	200	204	208	212	216	220	224	228	232	236	
6 to 8	192	196	200	204	208	211	215	219	223	227	231	
9 to 11	185	189	193	197	201	204	208	212	216	220	223	

RAC

TABLE 3 – SEGMENTED WEIGHTS OF PASSENGERS AGED 12 YEARS OR OLDER (IN POUNDS; WINTER)

Maximum Certified Passenger Seating Capacity	Ratio of Male (M) to Female (F) Passengers (in Percentages)										
	0M/100F	10M/90F	20M/80F	30M/70F	40M/60F	50M/50F	60M/40F	70M/30F	80M/20F	90M/10F	100M/0F
1 to 4	Use Actual Weights, Volunteered Weights or Estimated Weights										
5	202	206	210	214	218	222	226	230	234	238	242
6 to 8	198	202	206	210	214	217	221	225	229	233	237
9 to 11	191	195	199	203	207	210	214	218	222	226	229

NOTE: Multiply pounds (lbs) by 0.4536 to obtain kilogram (kg) value and correct to first decimal place. For example: To convert 220 lbs to kg, complete the calculation below.

$$\begin{aligned}
 &=220 \times 0.45360 \\
 &=99.792 \\
 &=99.8 \text{ kg}
 \end{aligned}$$

TABLE 4 – STANDARD WEIGHTS OF CHILDREN AND INFANTS

Summer		Winter
75 lbs or 34 kg	Children 2–11 years of age	75 lbs or 34 kg
30 lbs or 13.6 kg	Infants less than 2 years of age	30 lbs or 13.6 kg

(g) Checked Baggage and Cargo: The air operator must use the actual weight of checked baggage and cargo.

3.5.8 Fuel and Oil Weights

Fuel and oil weights were obtained from the Canadian Government Standards Bureau specifications. It should be remembered that the capacity of tanks is often expressed in U.S. gallons. The standard weights of fuel and oil are:

Temperature	-40°C			-20°C			0°C			15°C			30°C		
Fuel	LBS per			LBS per			LBS per			LBS per			LBS per		
	litre	imp. gal.	U.S. gal.	litre	imp. gal.	U.S. gal.	litre	imp. gal.	U.S. gal.	litre	imp. gal.	U.S. gal.	litre	imp. gal.	U.S. gal.
Aviation Kerosene CAN 2-3, 23-M81 (JET A, JET A-1, JET A-2) and Arctic Diesel	1.93	8.80	7.32	1.90	8.65	7.19	1.87	8.50	7.09	1.85	8.39	7.00	1.83	8.27	6.91
Aviation Wide Cut Fuel CAN 2-3, 23-M80 [F-40 (JP4) and JET B]	1.85	8.38	6.99	1.82	8.24	6.88	1.79	8.11	6.78	1.77	8.01	6.68	1.74	7.92	6.60
Aviation Gasoline All Grades CAN 2-3, 25-M82 (AV GAS)	1.69	7.68	6.41	1.65	7.50	6.26	1.62	7.33	6.12	1.59	7.20	6.01	1.56	7.07	5.90

RAC

Temperature	-10°C			0°C			10°C			20°C			30°C		
Lubricating oil	LBS per			LBS per			LBS per			LBS per			LBS per		
	litre	imp. gal.	U.S. gal.	litre	imp. gal.	U.S. gal.	litre	imp. gal.	U.S. gal.	litre	imp. gal.	U.S. gal.	litre	imp. gal.	U.S. gal.
Piston Engine 65 Grade	1.98	8.98	7.46	1.97	8.92	7.46	1.95	8.85	7.38	1.94	8.78	7.33	1.92	8.71	7.28
120 Grade	2.01	9.10	7.59	1.99	9.03	7.54	1.97	8.96	7.46	1.96	8.88	7.41	1.94	8.82	7.35

Turbine engine lubricating oil densities at 15°C

3cS oils 2.09 lbs/litre; 9.4 lbs/imp. gal.; 7.92 lbs/U.S. gal.

5cS oils 2.15 lbs/litre; 10.1 lbs/imp. gal.; 8.14 lbs/U.S. gal.

NOTE: The weights shown are for the maximum density of the various temperatures. The actual fuel weight for specific conditions can usually be obtained from the dealer supplying the fuel.

Conversion factors for litres to imperial gallons and kilograms to pounds are found in GEN 1.9.2.

3.6 FLIGHT PLANS AND FLIGHT ITINERARIES

3.6.1 When Required

CAR 602.73 states that no pilot-in-command shall operate an aircraft in VFR flight unless a VFR flight plan or a VFR flight itinerary has been filed, except where the flight is conducted within 25 NM of the departure aerodrome.

No pilot-in-command shall operate an aircraft in IFR flight unless an IFR flight plan has been filed. A pilot-in-command may file an IFR flight itinerary instead of an IFR flight plan where:

- (a) the flight is conducted, in part or in whole, outside controlled airspace; or
- (b) facilities are inadequate to permit the communication of flight plan information to an ATC unit, an FSS or a CARS.

Notwithstanding any of the requirements mentioned above, pilots are required to file a flight plan when operating between Canada and a foreign state.

3.6.2 Filing (CAR 602.75)

602.75

- (1) A flight plan shall be filed with an air traffic control unit, a flight service station or a community aerodrome radio station.
- (2) A flight itinerary shall be filed with a responsible person, an air traffic control unit, a flight service station or a community aerodrome radio station.

- (3) A flight plan or flight itinerary, shall be filed by
 - (a) sending, delivering or otherwise communicating the flight plan or flight itinerary or the information contained therein; and
 - (b) receiving acknowledgement that the flight plan or flight itinerary or the information contained therein has been received.

A “responsible person” means an individual who has agreed with the person who has filed a flight itinerary to ensure that, if the aircraft is overdue, the following are notified in the manner prescribed in this Section:

- (a) an ATC unit, an FSS or a CARS; or
- (b) an RCC.

NOTES: 1. The notification requires the flight itinerary information.

- 2. The expression flight service station used in the regulation includes a FIC. Flight plan information should be filed with an FIC, where complete briefing information is available. An IFR flight plan should be submitted to the flight planning section of an ACC.

The timely filing of IFR flight plans or flight itineraries is essential to allow ATC personnel time to extract and record the relevant content, correlate these new data with available information on other traffic under control, coordinate as necessary, and determine how the flight may best be integrated with the other traffic.

Accordingly, in order to assist ATS in improving the service provided and to allow sufficient time for input into the ATS data processing system, pilots are encouraged to file IFR flight plans or flight itineraries as early as practicable, preferably at least 30 min prior to their proposed departure time. Pilots

are expected to depart in accordance with the flight plan ETD. Some delay could be experienced if an IFR clearance is required less than 30 min after filing. It is also important that ATS be informed of the circumstances if commencement of an IFR flight is to be delayed. IFR flight itineraries are limited to one departure from and one entry into controlled airspace; multiple exits and entries into controlled airspace will not be accepted by ATS.

3.6.3 Flight Plan Requirements—Flights Between Canada and a Foreign State

A VFR or IFR flight plan must be filed prior to conducting any flight between Canada and a foreign state. If the flight is to any country other than the U.S., an ICAO flight plan must be filed.

For transborder flights departing from Canada to the U.S. or from the U.S. to Canada, it is solely the pilot's responsibility to make sure that U.S. Customs is properly notified. Failure to do so may subject the pilot to a penalty. (See FAL 2.3.2 for additional details).

ADCUS notification is no longer accepted on flight plans for transborder flights departing from Canada to the U.S. or from the U.S. to Canada. Pilots must make their own customs arrangements before departing on a transborder flight.

3.6.4 Opening a VFR Flight Plan or Flight Itinerary

A VFR flight plan or flight itinerary should normally be opened with a TWR, an FSS, an FIC or a CARS upon departure to activate the alerting service. The pilot is responsible for extending or cancelling the flight plan or flight itinerary if the flight is delayed or cancelled. If an extension or cancellation is not received by the proposed departure time, the responsible ATS unit will activate the flight plan or flight itinerary, using the ETD as the actual time of departure (ATD).

3.7 CHANGES TO THE INFORMATION IN A FLIGHT PLAN OR FLIGHT ITINERARY

Since control and alerting services are based primarily on information provided by the pilot, it is essential that modifications to flight plans and flight itineraries be communicated to an ATC unit, an FIC, a CARS or, as applicable, a responsible person concerned, as soon as practicable.

3.7.1 VFR Flight Plan or Flight Itinerary

CAR 602.76(3) and (4) specify that a pilot “shall notify as soon as practicable an air traffic control unit, a flight service station, a community aerodrome radio station or the responsible person,” of any change to:

- (a) the route of flight,

- (b) the duration of the flight; or

- (c) the destination aerodrome.

3.7.2 IFR Flight Plan or Flight Itinerary

CAR 602.76(1) and (2) specify that a pilot shall notify as soon as practicable an air traffic control unit, a flight service station, a community aerodrome radio station or a responsible person, as the case may be, of any change to:

- (a) the cruising altitude or cruising flight level;

- (b) the route of flight;

- (c) the destination aerodrome;

- (d) when in controlled airspace:

- (i) the true airspeed at the cruising altitude or cruising level where the change intended is 5% or more of the TAS specified in the IFR flight plan; or
- (ii) the Mach number, where the change intended is 0.01 or more of the Mach number that has been included in the ATC clearance.

Where the flight is being conducted in controlled airspace, the pilot shall receive ATC clearance before making the intended change.

3.8 COMPOSITE FLIGHT PLAN OR FLIGHT ITINERARY—VFR AND IFR

A composite flight plan or flight itinerary may be filed that describes part(s) of the route as operating under VFR and part(s) of the route as operating under IFR. All rules governing VFR or IFR apply to that portion of the route of flight. A composite flight plan or flight itinerary shall not be filed for an aircraft that will enter airspace controlled by the FAA, including CDA delegated to the FAA, as composite data cannot be correctly processed between NAV CANADA and FAA systems.

A pilot who files IFR for the first part of a flight and VFR for the next part will be cleared by ATC to the point within controlled airspace at which the IFR part of the flight ends. A pilot who files VFR for the first part of a flight and IFR for the next part is expected to contact the appropriate ATC unit for clearance prior to approaching the point where the IFR portion of the flight commences. If direct contact with an ATC unit is not possible, the pilot may request ATC clearance through an FIC. It is important that the flight continue under VFR conditions until appropriate IFR clearance within controlled airspace is issued by ATC and acknowledged by the pilot.

3.9 DEFENCE VFR FLIGHT PLANS AND DEFENCE FLIGHT ITINERARIES (CAR 602.145)

CAR 602.145 outlines the requirements when operating into or within the Air Defence Identification Zone (ADIZ). In order to ensure that the Air Traffic System (ATS) is aware that VFR flights will be operating into or within the ADIZ, ATS requires that pilots file a Defence Flight Plan or Flight Itinerary as depicted at RAC 3.16.2.

CAR 602.145 ADIZ states:

602.145 ADIZ

- (1) This Section applies in respect of aircraft before entering into and while operating within the ADIZ, the dimensions of which are specified in the *Designated Airspace Handbook*.
- (2) Every flight plan or flight itinerary required to be filed pursuant to this Section shall be filed with an air traffic control unit, a flight service station or a community aerodrome radio station.
- (3) The pilot-in-command of an aircraft whose point of departure within the ADIZ or last point of departure before entering the ADIZ has facilities for the transmission of flight plan or flight itinerary information shall:
 - (a) before takeoff, file a defence flight plan or defence flight itinerary;
 - (b) in the case of a VFR aircraft where the point of departure is outside the ADIZ,
 - (i) indicate in the flight plan or flight itinerary the estimated time and point of ADIZ entry, and
 - (ii) as soon as possible after takeoff, communicate by radio to an air traffic control unit, a flight service station or a community aerodrome radio station a position report of the aircraft's location, altitude, aerodrome of departure and estimated time and point of ADIZ entry; and
 - (c) in the case of a VFR aircraft where the point of departure is within the ADIZ, as soon as possible after takeoff, communicate by radio to an air traffic control unit, a flight service station or a community aerodrome radio station a position report of the aircraft's location, altitude and aerodrome of departure.
- (4) The pilot-in-command of an aircraft whose point of departure within the ADIZ or last point of departure before entering the ADIZ does not have facilities for the transmission of flight plan or flight itinerary information shall:
 - (a) as soon as possible after takeoff, file by radio communication a flight plan or flight itinerary; and
 - (b) in the case of a VFR aircraft, indicate in the flight plan or flight itinerary the estimated time and point of ADIZ entry, if applicable.

- (5) The pilot-in-command of a VFR aircraft shall revise the estimated time and point of ADIZ entry and inform an air traffic control unit, a flight service station or a community aerodrome radio station, when the aircraft is not expected to arrive:
 - (a) within plus or minus five minutes of the estimated time at:
 - (i) a reporting point,
 - (ii) the point of ADIZ entry, or
 - (iii) the point of destination within the ADIZ; or
 - (b) within 20 nautical miles of:
 - (i) the estimated point of ADIZ entry, or
 - (ii) the centreline of the route of flight indicated in the flight plan or flight itinerary.

3.10 INTERMEDIATE STOPS

Intermediate stops may not be included in a single IFR flight plan. Except for transborder flights, a single VFR flight plan or an IFR or VFR flight itinerary including one or more intermediate stops en route may be filed provided:

- (a) for VFR flight plans, the stop will be of short duration (for purposes such as boarding passengers, and refuelling);
- (b) for IFR flight itineraries, the stop will be in uncontrolled airspace; and
- (c) each intermediate stop is indicated by repeating the name of the stopping point and its duration in the route Section of the flight plan/itinerary. Record the duration of the stopover in hours and minutes with four consecutive digits. Example: CYXU 0045 CYXU. You may include a phone number for the stopover in the "Remark" section of the flight plan or flight itinerary, if available, as this may be useful in case of search and rescue.

Transborder Canada / U.S.A. flight plans shall be filed to the customs point of entry only to avoid unnecessary alerting service procedures from being initiated due to delays created in the process of clearing customs. Flight plans for locations beyond the customs point of entry may be filed with an FAA Flight Service Station.

When intermediate stops are planned, the "Estimated Elapsed Time" must be calculated as the total time to the final destination, including the duration of the intermediate stop(s). It should be noted that Search and Rescue (SAR) action would only be initiated at the specified SAR time or, in the event that a SAR time is not indicated, 60 minutes for a flight plan and 24 hours for a flight itinerary after the ETA at the final destination. Pilots wishing SAR action based on every leg of a flight should file one flight plan or flight itinerary for each stop.

3.10.1 Consecutive IFR Flight Plans

Consecutive IFR flight plans may be filed at the initial point of departure providing the following points are adhered to:

- (a) initial point of departure and enroute stops must be in Canada except that one flight plan will be accepted for a departure point within United States controlled airspace;
- (b) the sequence of stops will fall within one 24-hour period;
- (c) the flight planning unit must be provided with at least the following items of information for each stage of the flight:
 - (i) point of departure,
 - (ii) altitude,
 - (iii) route,
 - (iv) destination,
 - (v) proposed time of departure,
 - (vi) estimated elapsed time,
 - (vii) alternate,
 - (viii) fuel on board, and, if required,
 - (A) TAS,
 - (B) number of persons on board, and
 - (C) where an arrival report will be filed.

3.11 CROSS COUNTRY INSTRUMENT TRAINING FLIGHTS

A cross country instrument training flight is one in which there are no intermediate stops and one or more instrument approaches are made enroute. For example, an aircraft departs Airport A, completes a practice approach at Airport B and either lands at destination Airport C or returns to land at Airport A.

The following apply:

- (a) A single flight plan is filed.
- (b) Those enroute locations at which instrument approaches and overshoots are requested shall be listed in the “Other Information” portion of the flight plan form, together with the estimated period of time to carry out each approach (i.e., REQ NDB RWY 32 AT B-15 MIN.).
- (c) The estimated elapsed time (EET) of the flight plan form is NOT to include the estimated time to carry out approaches at the enroute locations.
- (d) ATC will normally clear the aircraft to final destination.
- (e) If it is not practicable to clear the aircraft to final destination or to assign an operationally suitable altitude with the initial clearance, a time or specific location for the aircraft to expect further clearance to the destination or to a higher altitude will be issued with the initial clearance.

(f) When an enroute approach clearance is requested, a missed approach clearance will be issued to the aircraft prior to the commencement of the approach.

(g) If traffic does not permit an approach, holding instructions will be issued to the aircraft if requested by the pilot.

3.12 CLOSING

In order to comply with CAR 602.77, an arrival report for a flight plan shall be submitted to an ATC unit, an FSS (or an FIC) or a CARS as soon as practicable after landing but not later than:

- (a) the SAR time specified in the flight plan; or
- (b) where no SAR time is specified in the flight plan, one hour after the last reported ETA.

A pilot who terminates a flight itinerary shall ensure that an arrival report is filed with an ATC unit, an FSS (or an FIC), a CARS or, where the flight itinerary was filed with a responsible person, the responsible person as soon as practicable after landing but not later than:

- (a) the SAR time specified in the flight itinerary; or
- (b) where no SAR time was specified in the flight itinerary, 24 hours after the last reported ETA.

A pilot who terminates an IFR flight at an aerodrome where there is an operating ATC unit, FSS or where RAAS is provided, is not required to file an arrival report unless requested to do so by the appropriate ATC unit or FSS.

When submitting an arrival report, the pilot should clearly indicate that he/she was operating on a flight plan or flight itinerary and wishes it to be closed. Failure to close a flight plan or flight itinerary will initiate SAR action. It should not be assumed that ATS personnel will automatically file arrival reports for VFR flights at locations served by control towers and FSSs or an RCO. Toll-free calls, as outlined in the CFS, may be made to an ATS facility for this purpose.

3.12.1 Arrival Report

CAR 602.78 specifies that the contents of an arrival report for a flight plan or flight itinerary, which are listed in the CFS, shall include:

- (a) the aircraft registration mark, flight number or radio call sign;
- (b) the type of flight plan or flight itinerary;
- (c) the departure aerodrome;
- (d) the arrival aerodrome, and
- (e) the date and time of arrival.

3.12.2 Closing of a Flight Plan or Flight Itinerary Prior to Landing

A pilot, who conducts a flight in respect of which a flight plan or flight itinerary has been filed with an ATC unit, FIC, FSS, or CARS, has the option of closing the flight plan or flight itinerary with any of these agencies prior to landing.

The closing of a flight plan or flight itinerary prior to landing is considered as filing an arrival report, and as such, it will result in the termination of all alerting services with respect to SAR notification.

When flying IFR in airspace under the jurisdiction of Canadian ATC, use of the phrase “Cancelling IFR” results in ATC discontinuing the provision of IFR separation, but it does not automatically close the flight plan or itinerary. Therefore, alerting service with regard to SAR notification is still active and is based on the information submitted in the original flight plan or itinerary. Because the pilot is now flying in accordance with VFR, the flight plan or itinerary must either be closed prior to landing, or an arrival report filed after landing, with an ATC unit, a FIC, a FSS or a CARS.

When flying IFR in the U.S.A. or landing at a Canadian airport that underlies airspace delegated to the control of the FAA, use of the phrase “Cancelling IFR” results in ATC discontinuing the provision of IFR separation and also closes the flight plan or itinerary. Therefore, alerting service with regard to SAR notification is also terminated, unless the pilot files and activates a VFR flight plan.

3.13 FUEL REQUIREMENTS

The fuel requirements contained in this Section do not apply to gliders, balloons or ultra-light aeroplanes. (CAR 602.88)

In addition to VFR and IFR fuel requirements, every aircraft shall carry an amount of fuel that is sufficient to provide for

- (a) taxiing and foreseeable delays prior to takeoff;
- (b) meteorological conditions;
- (c) foreseeable air traffic routings and traffic delays;
- (d) landing at a suitable aerodrome in the event of loss of cabin pressurization or, in the case of a multi-engine aircraft, failure of any engine, at the most critical point during the flight; and
- (e) any other foreseeable conditions that could delay the landing of the aircraft.

3.13.1 VFR Flight

An aircraft operated in VFR flight shall carry an amount of fuel that is sufficient to allow the aircraft

- (a) in the case of an aircraft other than a helicopter,
 - (i) when operated during the day, to fly to the destination aerodrome and then to fly for 30 minutes at normal cruising speed, or
 - (ii) when operated at night, to fly to the destination aerodrome and then to fly for 45 minutes at normal cruising speed, or
- (b) in the case of a helicopter, to fly to the destination aerodrome and then to fly for 20 min. at normal cruising speed.

3.13.2 IFR Flight

An aircraft operated in IFR flight shall carry an amount of fuel that is sufficient to allow the aircraft

- (a) in the case of a propeller-driven aeroplane,
 - (i) where an alternate aerodrome is specified in the flight plan or flight itinerary, to fly to and execute an approach and a missed approach at the destination aerodrome, to fly to and land at the alternate aerodrome, and then to fly for a period of 45 minutes, or
 - (ii) where an alternate aerodrome is not specified in the flight plan or flight itinerary, to fly to and execute an approach and a missed approach at the destination aerodrome and then to fly for a period of 45 minutes; or
- (b) in the case of a turbojet powered aeroplane or a helicopter,
 - (i) where an alternate aerodrome is specified in the flight plan or flight itinerary, to fly to and execute an approach and a missed approach at the destination aerodrome, to fly to and land at the alternate aerodrome, and then to fly for a period of 30 minutes, or
 - (ii) where an alternate aerodrome is not specified in the flight plan or flight itinerary, to fly to and execute an approach and a missed approach at the destination aerodrome and then to fly for a period of 30 minutes.

3.14 REQUIREMENTS FOR ALTERNATE AERODROME – IFR FLIGHT

Except as otherwise authorized by the Minister in an air operator certificate (AOC) or in a private operator certificate, no pilot-in-command shall operate an aircraft in IFR flight unless the IFR flight plan or IFR flight itinerary that has been filed for the flight includes an alternate aerodrome having a landing area suitable for use by that aircraft. No pilot-in-command of an aircraft shall include an alternate aerodrome in an IFR flight plan or IFR flight itinerary unless available weather information indicates that the ceiling and ground visibility at the alternate aerodrome will, at the expected time of arrival, be at or above the alternate aerodrome weather minima criteria specified in the CAP. (CARs 602.122 and 602.123)

Aerodrome forecasts (TAF) that contain the terms BECMG, TEMPO or PROB may be used to determine the weather suitability of an aerodrome as an alternate, provided that:

- (a) where conditions are forecast to improve, the forecast BECMG condition shall be considered to be applicable as of the end of the BECMG time period, and these conditions shall not be below the published alternate minima requirements for that aerodrome;
- (b) where conditions are forecast to deteriorate, the forecast BECMG condition shall be considered to be applicable as of the start of the BECMG time period, and these conditions shall not be below the published alternate minima requirements for that aerodrome;
- (c) the forecast TEMPO condition shall not be below the published alternate minima requirements for that aerodrome; and
- (d) the forecast PROB condition shall not be below the appropriate landing minima for that aerodrome.

3.14.1 Alternate Aerodrome Weather Minima Requirements

Authorized weather minima for alternate aerodromes are to be determined using the information presented in the tables below. The “Alternate Weather Minima Requirements” table presented in the CAP GEN (reproduced below) applies to all approach charts, except where use as an alternate is not authorized on the chart. The minima derived for an alternate aerodrome shall be consistent with aircraft performance, navigation-equipment limitations, functioning navigation aids, type of weather forecast and runway to be used.

Pilots can take credit for a GNSS approach at an alternate aerodrome, provided that the planned destination aerodrome is served by a functioning traditional approach aid; and the pilot verifies that the integrity, provided by RAIM or WAAS (wide area augmentation system), and that is required for a lateral navigation (LNAV) approach, is expected to be available at the planned alternate aerodrome at the expected time of arrival at

the alternate, as explained in COM 3.16.12. Note that if credit is taken for a GNSS approach at an alternate aerodrome to fulfill the legal requirements for flight planning, no part of the approach at the destination may rely on GNSS. Otherwise, when determining alternate aerodrome weather minima requirements, the pilot shall only take credit for functioning traditional aids at that aerodrome.

If credit is being taken for a GNSS-based approach at the alternate, the published LNAV minima are the lowest landing limits for which credit may be taken when determining alternate weather minima requirements. No credit may be taken for lateral navigation / vertical navigation (LNAV/VNAV) or localizer performance with vertical guidance (LPV) minima.

Pilots may take credit for the use of GNSS in lieu of traditional ground-based NAVAIDs at a filed alternate aerodrome, as per COM 3.16.9 and COM 3.16.12.

ALTERNATE WEATHER MINIMA REQUIREMENTS	
FACILITIES AVAILABLE AT SUITABLE ALTERNATE	WEATHER REQUIREMENTS
TWO OR MORE USABLE PRECISION APPROACHES, each providing straight-in minima to separate suitable runways	400-1 or 200-1/2 above lowest usable HAT and visibility, whichever is greater.
ONE USABLE PRECISION APPROACH	600-2* or 300-1 above the lowest usable HAT and visibility, whichever is greater.
NON-PRECISION ONLY AVAILABLE	800-2* or 300-1 above the lowest usable HAT/HAA and visibility, whichever is greater.
NO IFR APPROACH AVAILABLE	Forecast weather must be no lower than 500 ft above a minimum IFR altitude that will permit a VFR approach and landing.
FOR HELICOPTERS, where instrument approach procedures are available	Ceiling 200 ft above the minima for the approach to be flown, and visibility at least 1 SM, but never less than the minimum visibility for the approach to be flown.

* 600-2 and 800-2, as appropriate, are considered to be STANDARD ALTERNATE MINIMA.

Should the selected alternate weather requirements meet the standard minima, then the following minima are also authorized:

STANDARD ALTERNATE MINIMA		IF STANDARD IS APPLICABLE, THEN THE FOLLOWING MINIMA ARE ALSO AUTHORIZED	
CEILING	VISIBILITY	CEILING	VISIBILITY
600	2	700 800	1 1/2 1
800	2	900 1000	1 1/2 1

RAC

- NOTES** 1: These requirements are predicated upon the aerodrome having a TAF available.
- 2: Aerodromes served with an AERODROME ADVISORY forecast may qualify as an alternate, provided the forecast weather is no lower than 500 ft above the lowest usable HAT/HAA and the visibility is not less than 3 mi.
- 3: Aerodromes served with a GRAPHIC AREA FORECAST (GFA) may qualify as an alternate, provided the forecast weather contains:
- (a) no cloud lower than 1 000 ft above the lowest usable HAT/HAA;
 - (b) no cumulonimbus; and
 - (c) a visibility that is not less than 3 mi.
- 4: Ceiling minima are calculated by reference to the procedure HAA or HAT. Ceiling values in aviation forecasts are established in 100–ft increments. Up to 20 ft, use the lower 100–ft increment; above 20 ft, use the next higher 100–ft increment:

Examples:

- HAA 620 ft = ceiling value of 600 ft;
- HAA 621 ft = ceiling value of 700 ft;
- HAT 420 ft = ceiling value of 400 ft;
- HAT 421 ft = ceiling value of 500 ft.;

5: Calculated visibilities should not exceed 3 mi.

Caution: All heights specified in a GFA are ASL, unless otherwise indicated.

The emphasis of these criteria is placed upon the availability of the lowest usable landing HAT/HAA and visibility for an aerodrome. In determining the lowest usable landing HAT/HAA and visibility, the pilot should consider:

- (a) the operational availability of the ground navigational equipment by consulting NOTAM;
- (b) the compatibility of the aircraft equipment with the ground navigational equipment;
- (c) the forecast surface wind conditions could dictate the landing runway and associated approach minima;
- (d) the operational applicability of terms BECMG, TEMPO and PROB within the forecast (see RAC 3.14);
- (e) all heights mentioned within a GFA are ASL heights, unless otherwise indicated, and the terrain elevation must be applied in order to determine the lowest forecast ceiling at a particular location; and
- (f) alternate minima values determined from a previous flight operation may not be applicable to a subsequent flight operation.

3.15 COMPLETION OF CANADIAN FLIGHT PLANS AND FLIGHT ITINERARIES AND ICAO FLIGHT PLANS

3.15.1 General

The flight plan form is to be used for Canadian flight plans or flight itineraries and ICAO flight plans. Completion of the form is simply a matter of inserting the requested information in the appropriate boxes. The white boxes relate to required information for Canadian flight plans and for flight itineraries and for ICAO flight plans. The shaded boxes indicate the information which is applicable only to Canadian flight plans and flight itineraries.

NOTE: A Canadian flight plan is used for flights from Canada to the United States.

3.15.2 Canadian

A Canadian flight plan or flight itinerary shall contain such information as is specified in the CFS, including:

- aircraft identification
- flight rules
- type of flight
- number of aircraft (if more than one)
- type of aircraft
- wake turbulence category
- equipment
- departure aerodrome
- time of departure (UTC)—proposed/actual
- cruising speed
- altitude/level
- route
- destination aerodrome
- EET en-route
- SAR time*
- destination alternate aerodrome(s)
- other information
- endurance (flight time in hours and minutes)
- total number of persons on board
- type of ELT*
- survival equipment (type, jackets, dinghies)
- aircraft colour and markings
- remarks (regarding other survival equipment)
- arrival report—where it will be filed*
- name and number or address of person or company to be notified if SAR action is initiated*
- pilot's name
- pilot's licence number (Canadian pilot licence only)*

* Not required for an ICAO flight plan

3.15.3 ICAO

Flight plans for international flights originating in, or entering, Canada shall be filed in the ICAO format, as specified in ICAO Doc 4444—*Operations 5-2 PANS-RAC* (DOC 4444-RAC/501 Mil GPH 204 DOC FLIGHT INFO PUBLICATION).

For the purpose of flight planning, flights between Canada and the continental United States are not classed as “international flights”.

3.15.4 Instructions for Completing the Form

3.15.4.1 General

Adhere closely to the prescribed formats and manner of specifying data.

Commence inserting data in the first space provided. Where excess space is available, leave unused spaces blank.

All times should be indicated in UTC, using four digits.

Indicate all EETs using four digits (hours and minutes) for flight plans.

NOTE: Because EETs on a flight itinerary may include days as well as hours and minutes, insert the EET using six digits, if required.

The shaded area preceding Item 3 is to be completed by ATS and COM services, unless the responsibility for originating flight plan messages has been delegated.

NOTE: The term “aerodrome,” where used in the flight plan, is intended to also cover sites other than aerodromes that may be used by certain types of aircraft, e.g. helicopters or balloons.

3.15.4.2 Instructions for Insertion of ATS Data

Complete Items 7 to 18 as indicated hereunder.

Complete Item 19 as well to facilitate alerting of SAR services.

NOTE: Item numbers on the form are not consecutive as they correspond to Field Type numbers in ATS messages.

Use location indicators listed in Canadian AIPs (defined in CAR 300.01), in ICAO Doc 7910—*Location Indicators*, and in FAA Order 7350.7—*Location Identifiers*.

3.16 CONTENTS OF A FLIGHT PLAN AND FLIGHT ITINERARY

3.16.1 Item 7: Aircraft Identification (not exceeding seven alphanumeric characters and without hyphens or symbols)

Canadian:

Normally, this consists of the aircraft registration letters or the company designator followed by the flight number.

Examples:

- Aircraft registration: N123B, CGABC, 4XGUC
- Operating agency and flight number: ACA123, KLM672
- Tactical call sign: BRUNO12, SWIFT45, RED1

ICAO:

- (a) the ICAO designator for the aircraft operating agency followed by the flight identification (e.g. KLM511, NGA213, JTR25) when in radiotelephony the call sign to be used by the aircraft will consist of the ICAO telephony designator for the operating agency followed by the flight identification (e.g. KLM511, NIGERIA213, JESTER25); OR
- (b) the nationality or common mark and registration mark of the aircraft (e.g. E1AKO, 4XBCD, N2567GA), when:
 - (i) in radiotelephony, the call sign to be used by the aircraft will consist of this identification alone (e.g. CGAJS), or will be preceded by the ICAO telephony designator for the aircraft operating agency (e.g. BLIZZARD CGAJS); or
 - (ii) the aircraft is not equipped with radio.

NOTES 1: Standards for nationality, common and registration marks to be used are contained in ICAO Annex 7, Chapter 2.

2: Provisions for the use of radiotelephony call signs are contained in ICAO Annex 10, Volume II, Chapter 5. ICAO designators and telephony designators for aircraft operating agencies are contained in ICAO Doc 8585—*Designators for Aircraft Operating Agencies, Aeronautical Authorities and Services*.

3.16.2 Item 8: Flight Rules and Type of Flight

3.16.2.1 Flight Rules (one character) (Canadian and ICAO)

INSERT one of the following letters to denote the category of flight rules with which the pilot intends to comply:

- I if it is intended that the entire flight will be operated under IFR;
- V if it is intended that the entire flight will be operated under VFR;
- Y if the flight initially will be operated under IFR, followed by one or more subsequent changes of flight rules; or
- Z if the flight initially will be operated under VFR, followed by one or more subsequent changes of flight rules.

If “Y” or “Z” is filed, specify, in the Route section of the flight plan (Item 15), the point(s) where a change in flight rules is planned. Similarly, where there is more than one change in the type of flight rules, the code to be used is to reflect the first rule, i.e. use “Z” for VFR/IFR/VFR.

3.16.2.2 Type of Flight (up to two characters, as applicable)

INSERT up to two of the following letters to denote the type of flight when so required by the appropriate ATS authority:

First character (Canadian only, as applicable):

- C for controlled VFR;
- D for defence flight plan;
- E for defence flight itinerary;
- F for flight itinerary.

Second character (ICAO, as applicable):

- S for scheduled air service;
- N for non-scheduled air transport operation;
- G for general aviation;
- M for military;
- X for other than the preceding categories.

Specify the status of a flight following the indicator “STS” in Item 18, or when necessary to denote other reasons for specific handling by ATS, indicate the reason following the indicator “RMK/” in Item 18.

3.16.3 Item 9: Number and Type of Aircraft and Wake Turbulence Category

3.16.3.1 Number of Aircraft (one or two characters)

INSERT the number of aircraft, if more than one.

3.16.3.2 Type of Aircraft (two to four characters)

INSERT the appropriate ICAO aircraft type designator. If no such designator has been assigned, or in the case of formation flights comprising more than one type, insert “ZZZZ” and specify in Item 18 the number(s) and type(s) of aircraft preceded by “TYP”.

3.16.3.3 ICAO Wake Turbulence Category (one character)

INSERT one of the following letters to indicate the wake turbulence category of the aircraft:

- H (HEAVY) to indicate an aircraft type with a maximum certificated take-off mass of 136 000 kg (300 000 lbs) or more.
- M (MEDIUM) to indicate an aircraft type with a maximum certificated take-off mass of less than 136 000 kg (300 000 lbs) but more than 7 000 kg (15 500 lbs).
- L (LIGHT) to indicate an aircraft type with a maximum certificated take-off mass of 7 000 kg (15 500 lbs) or less.

3.16.4 Item 10: Equipment and Capabilities (Canadian and ICAO)

Capabilities comprise the following elements:

- (a) presence of relevant serviceable equipment on board the aircraft;
- (b) equipment and capabilities commensurate with flight crew qualifications; and
- (c) where applicable, authorization from the appropriate authority.

The communication (COM), navigation (NAV), approach aid and SSR equipment on board and its serviceability must be inserted by adding the appropriate suffixes. The first suffixes will denote the COM, NAV and approach aid equipment, followed by an oblique stroke, and another suffix to denote the SSR equipment.

3.16.4.1 Radio Communication, Navigation and Approach Aid Equipment and Capabilities

INSERT one letter as follows:

“N” if no COM, NAV or approach aid equipment for the route to be flown is carried, or the equipment is unserviceable; OR

“S” if standard COM, NAV and approach aid equipment for the route to be flown is carried and available (see NOTE 1)

Information on navigation capability is provided to ATC for clearance and routing purposes.

AND/OR INSERT one or more of the following letters to indicate the serviceable COM, NAV and approach aid equipment and capabilities available.

A	GBAS landing system	J7	CPDLC FANS 1/A SATCOM (Iridium)
B	LPV (APV with SBAS)	K	MLS
C	LORAN C	L	ILS
D	DME	M1	ATC RTF SATCOM (INMARSAT)
E1	FMC WPR ACARS	M2	ATC RTF (MTSAT)
E2	D-FIS ACARS	M3	ATC RTF (Iridium)
E3	PDC ACARS	O	VOR
F	ADF	P1–P9	Reserved for RCP
G	GNSS (see NOTE 2)	R	PBN approved (see NOTE 4)
H	HF RTF	T	TACAN
I	Inertial Navigation	U	UHF RTF
J1	CPDLC ATN VDL Mode (see NOTE 3)	V	VHF RTF
J2	CPDLC FANS 1/A HF DL	W	RVSM approved
J3	CPDLC FANS 1/A VDL mode 4	X	MNPS approved
J4	CPDLC FANS 1/A VDL mode 2	Y	VHF with 8.33 kHz channel spacing capability
J5	CPDLC FANS 1/A SATCOM (INMARSAT)	Z	Other equipment carried or other capabilities (see NOTE 5)
J6	CPDLC FANS 1/A SATCOM (MTSAT)		

Any alphanumeric characters not indicated above are reserved.

NOTES 1: If the letter “S” is used, standard equipment is considered to be VHF, RTF, VOR and ILS, unless another combination is prescribed by the appropriate ATS authority.

2: ICAO: If the letter “G” is used, the types of external GNSS augmentation, if any, are specified in Item 18 following the indicator “NAV/” and separated by a space.

Canadian:

When using the letter “G” on an IFR flight plan, the GPS receiver must be approved in accordance with the requirements specified in Technical Standard Order (TSO) C-129 (Class A1, A2, B1, B2, C1 or C2), installed and approved in accordance with the appropriate sections of the *Airworthiness Manual*, and operated in accordance with the approved flight manual or flight manual supplement. Pilots are encouraged to use the letter “G” on VFR flight plans when using GPS to assist VFR navigation. TSO C-129 receivers are not mandatory for VFR flights.

See *RTCA/EUROCAE Interoperability Requirements Standard For ATN Baseline 1* (ATN

B1 INTEROP Standard—DO-280B/ED-110B) for data link services, ATC clearance and information, ATC communications management, and ATC microphone check.

4: If the letter “R” is used, the performance-based navigation levels that can be met are specified in Item 18 following the indicator “PBN/”. Guidance material on the application of performance-based navigation to a specific route segment, route or area is contained in the *Performance-Based Navigation Manual* (ICAO Doc 9613).

5: If the letter “Z” is used, specify in Item 18 the other equipment carried, or other capabilities, preceded by “COM/”, “NAV/” and/or “DAT/”, as appropriate.

3.16.4.2 Surveillance Equipment and Capabilities

INSERT “N” if no surveillance equipment for the route to be flown is carried, or the equipment is unserviceable, OR

INSERT one or more of the following descriptors, to a maximum of 20 characters, to describe the serviceable surveillance equipment and/or capabilities on board:

SSR Modes A and C

- A Transponder—Mode A (four digits—4096 codes);
- C Transponder—Mode A (four digits—4096 codes) and Mode C

SSR Mode S

- E Transponder—Mode S, including aircraft identification, pressure-altitude and extended squitter (ADS-B) capability;
- H Transponder—Mode S, including aircraft identification, pressure-altitude and enhanced surveillance capability;
- I Transponder—Mode S, including aircraft identification, but no pressure-altitude capability;
- L Transponder—Mode S, including aircraft identification, pressure-altitude, extended squitter (ADS-B) and enhanced surveillance capability;
- P Transponder—Mode S, including pressure-altitude transmission, but no aircraft identification capability;
- S Transponder—Mode S, including both pressure-altitude and aircraft identification capability;

X Transponder—Mode S with neither aircraft identification nor pressure-altitude capability.

NOTE: Enhanced surveillance capability is the ability of the aircraft to down-link aircraft-derived data via a Mode S transponder.

ADS-B

- B1 ADS-B with dedicated 1090 MHz ADS-B “out” capability;
- B2 ADS-B with dedicated 1090 MHz ADS-B “out” and “in” capability;
- U1 ADS-B “out” capability using UAT;
- U2 ADS-B “out” and “in” capability using UAT;
- V1 ADS-B “out” capability using VDL Mode 4;
- V2 ADS-B “out” and “in” capability using VDL Mode 4.

ADS-C

- D1 ADS-C with FANS 1/A capabilities;
- G1 ADS-C with ATN capabilities.

Alphanumeric characters not indicated above are reserved.

Example: ADE3RV/HB2U2V2G1

NOTE: Additional surveillance application should be listed in Item 18 following the indicator “SUR/”.

3.16.5 Item13: Departure Aerodrome and Time

3.16.5.1 Departure Aerodrome (maximum four characters)

ICAO:

INSERT the ICAO four-letter location indicator of the departure aerodrome as specified in ICAO Doc 7910—*Location Indicators*; OR

Canadian:

INSERT the four-character location indicator of the departure aerodrome; OR

Canadian and ICAO:

If no location indicator has been assigned:

INSERT “ZZZZ” and specify in Item 18 the name and location of the aerodrome preceded by “DEP/”; OR

INSERT the first point of the route or the marker radio beacon preceded by “DEP/”, if the aircraft has not taken off from the aerodrome.

3.16.5.2 Time (maximum four characters)

Indicate the hour and minutes in UTC.

NOTE: Pilots may file a flight plan or flight itinerary up to 24 hr in advance of the departure time.

3.16.6 Item 15: Cruising Speed, Altitude/Level and Route

Canadian:

NOTES 1: On designated airways and air routes, IFR flights may be operated at the published MEA/MOCA, except that in winter, when air temperatures may be much lower than those of the ICAO Standard Atmosphere (ISA), aircraft should be operated at an altitude which is at least 1 000 ft higher than the published MEA/MOCA (see RAC 8.5 and RAC 9.5).

2: Preferred IFR routes, published in the CFS—Planning section, have been established to aid in the efficient and orderly management of air traffic between selected aerodromes. Pilots are encouraged to file these routes.

Canadian and ICAO:

INSERT

- the first cruising speed as described in (a),
- the first cruising level as described in (b), and
- the route description as described in (c).

(a) Cruising speed (maximum five characters)

INSERT the true airspeed for the first or the whole cruising portion of the flight, in terms of:

- Kilometres per hour (ICAO only), expressed as “K” followed by four figures (e.g. K0830); OR
- Knots, expressed as “N” followed by four figures (e.g. N0485); OR
- True Mach number, when so prescribed by the appropriate ATS authority, to the nearest hundredth of unit Mach, expressed as “M” followed by three figures (e.g. M082).

(b) Cruising level (maximum five characters)

INSERT the planned cruising level for the first or the whole portion of the route to be flown, in terms of:

- Flight level, expressed as “F” followed by three figures (e.g. F085, F330); OR
- Standard metric level in tens of metres (ICAO only), expressed as “S” followed by four figures (e.g. S1130), when so prescribed by the appropriate ATS authorities; OR
- Altitude in hundreds of feet, expressed as “A” followed by three figures (e.g. A045, A100); OR
- Altitude in tens of metres (ICAO only), expressed as “M” followed by four figures (e.g. M0840); OR
- For uncontrolled VFR flights, the letters “VFR” (ICAO only).

(c) Route (including changes of speed, level and/or flight rules)**3.16.6.1 Flights Along Designated ATS Routes:**

INSERT

- if the departure aerodrome is located on, or connected to, the ATS route:
 - the designator of the first ATS route (e.g. if the departure aerodrome is Carp: T614 TUKIR, etc.); OR
- if the departure aerodrome is not located on, or connected to, the ATS route:
 - (ICAO only) the letters “DCT”, followed by the joining point of the first ATS route, followed by the designator of the ATS route (e.g. if the departure aerodrome is Ottawa: DCT IKLAX T634, etc.);
 - (Canadian only) the joining point of the first ATS route, followed by the designator of the ATS route (e.g. if the departure aerodrome is Ottawa: YOW T616, etc.).

INSERT each point at which a change of speed or level is planned to commence, or a change of ATS route, or a change of flight rules is planned (e.g. AGLUK/N0200A170 IFR).

NOTE: When a transition is planned between a lower and an upper ATS route and the routes are oriented in the same direction, the point of transition need not be inserted.

FOLLOWED IN EACH CASE BY

- the designator of the next ATS route segment, even if it is the same as the previous one (e.g. if the departure aerodrome is Québec: DICEN T680 LETAK T616, etc.); OR
- if the flight to the next point is outside a designated route:
 - (ICAO only) the letters “DCT”, unless both points are defined by geographical coordinates (e.g. if the departure aerodrome is Québec: DCT YQB DCT FLEUR DCT YYY, etc.);
 - (Canadian only) the next point (e.g. if the departure aerodrome is Québec: YQB FLEUR YYY etc.). The absence of “DCT” between points on a Canadian flight plan or flight itinerary indicates direct flight.

3.16.6.2 Flights Outside Designated ATS Routes:**ICAO:**

INSERT points normally not more than 30 min flying time or 370 km (200 NM) apart, including each point at which a change of speed or level, a change of track, or a change of flight rules is planned; OR

When required by appropriate ATS authority(ies),

DEFINE the track of flights operating predominantly in an east-west direction between 70°N and 70°S by reference to significant points formed by the intersections of half or whole degrees of latitude with meridians spaced at intervals of 10° of longitude. For flights operating in areas outside those latitudes, the tracks shall be defined by significant points formed by the intersection of parallels of latitude with meridians normally spaced at 20° of longitude. The distance between significant points shall, as far as possible, not exceed one hour's flight time. Additional significant points shall be established as deemed necessary.

For flights operating predominantly in a north-south direction, define tracks by reference to significant points formed by the intersection of whole degrees of longitude with specified parallels of latitude which are spaced at 5°.

INSERT “DCT” between successive points unless both points are defined by geographical coordinates or by bearing and distance.

Canadian:

INSERT points at which a change of speed or level, a change of track, or a change of flight rules is planned. Absence of “DCT” between points on a Canadian flight plan or itinerary indicates direct flight; OR

When required by appropriate ATS authority(ies),

Canadian and ICAO:

USE the conventions in (1) to (5), below, and SEPARATE each sub-item by a space.

(1) ATS route (two to seven characters):

The coded designator assigned to the route or route segment including, where appropriate, the coded designator assigned to the standard departure or arrival route (e.g. BCN1, B1, R14, UB10, KODAP2A).

NOTE: Provisions for the application of route designators are contained in ICAO Annex 11, Appendix 1.

(2) Significant point (two to eleven characters):

The coded designator (two to five characters) assigned to the point (e.g. LN, MAY, HADDY), OR

If no coded designator has been assigned, one of the following ways:

- (i) Degrees only (seven characters):
Two figures describing latitude in degrees, followed by “N” (North) or “S” (South), followed by three figures describing longitude in degrees, followed by “E” (East) or “W” (West). Make up the correct number of figures, where necessary, by insertion of zeros, e.g. 46N078W.
- (ii) Degrees and minutes (11 characters):
Four figures describing latitude in degrees, and tens and units of minutes followed by “N” (North) or “S” (South), followed by five figures describing longitude in degrees and tens and units of minutes, followed by “E” (East) or “W” (West). Make up the correct number of figures, where necessary, by insertion of zeros, e.g. 4620N07805W.
- (iii) Bearing and distance from a significant point:
The identification of the significant point followed by the bearing from the point in the form of three figures giving degrees magnetic followed by the distance from the point in the form of three figures expressing nautical miles. In areas of high latitude where it is determined by the appropriate authority that reference to degrees magnetic is impractical, degrees true may be used. Make up the correct number of figures, where necessary, by insertion of zeros, e.g. a point 180° magnetic at a distance of 40 NM from VOR “DUB” should be expressed as DUB180040.

(3) Change of speed or level (maximum 21 characters):

The point at which a change of speed (5 percent TAS or 0.01 Mach or more) or a change of level is planned to commence, expressed exactly as in (2), above, followed by an oblique stroke and both the cruising speed and the cruising level, expressed exactly as in (a) and (b), above, without a space between them, even when only one of these quantities will be changed.

Examples:

- LN/N0284A045
- MAY/N0305F180
- HADDY/N0420F330
- 4602N07805W/N0500F350
- 46N078W/M082F330
- DUB180040/N0350M0840

(4) Change of flight rules (maximum three characters):

The point at which the change of flight rules is planned, expressed exactly as in (2) or (3), above, as appropriate, followed by a space and one of the following:

- VFR if from IFR to VFR
- IFR if from VFR to IFR

Examples:

- LN VFR
- LN/N0284A050 IFR

(5) Cruise climb (maximum 28 characters):

The letter “C” followed by an oblique stroke; THEN the point at which cruise climb is planned to start, expressed exactly as in (2), above, followed by an oblique stroke; THEN the speed to be maintained during cruise climb, expressed exactly as in (a), above, followed by the two levels defining the layer to be occupied during cruise climb, each level expressed exactly as in (b), above, or the level above which cruise climb is planned followed by the letters “PLUS”, without a space between them.

Examples:

- C/48N050W/M082F290F350
- C/48N050W/M082F290PLUS
- C/52N050W/M220F580F620

3.16.7 Item 16: Destination Aerodrome, Total EET, SAR Time (for flights in Canada only) and Destination Alternate Aerodrome(s)

3.16.7.1 Destination Aerodrome and Total EET (maximum 10 characters)

ICAO:

INSERT the ICAO four-letter location indicator of the destination aerodrome as specified in ICAO Doc 7910—*Location Indicators*; OR

Canadian:

INSERT the four-character location indicator of the destination aerodrome; OR

NOTE: In the case of a Canadian flight itinerary, as applicable, the EET may also include the number of days. The total duration of the flight itinerary shall not exceed 30 days.

Canadian and ICAO:

If no location indicator has been assigned,

INSERT “ZZZZ” and specify in Item 18 the name and location of the aerodrome, preceded by “DEST/”.

THEN, without a space, INSERT the total EET.

NOTE: For a flight plan received from an aircraft in flight, the total EET is the estimated time from the first point of the route to which the flight plan applies to the termination point of the flight plan.

INSERT SAR time (four digits) (maximum of 24 hr)

3.16.7.2 Destination Alternate Aerodrome(s)

ICAO:

INSERT the ICAO four-letter location indicator(s) of not more than two destination alternate aerodromes, as specified in ICAO Doc 7910—*Location Indicators*, separated by a space; OR

Canadian:

INSERT the four-character location indicator of not more than two destination alternate aerodromes, separated by a space; OR

Canadian and ICAO:

If no location indicator has been assigned to the destination alternate aerodrome(s),

INSERT “ZZZZ” and specify in Item 18 the name and location of the destination alternate aerodrome(s), preceded by “ALTN/”.

NOTE: No alternate is required on a VFR flight plan or itinerary.

3.16.8 Item 18: Other Information

NOTE: Use of indicators not included under this item may result in data being rejected, processed incorrectly or lost.

Hyphens or oblique strokes should only be used as prescribed below.

INSERT “0” (zero) if no other information; OR

Any other necessary information in the sequence shown hereunder, in the form of the appropriate indicator selected from those defined hereunder, followed by an oblique stroke and the information to be recorded.

STS/ Reason for special handling by ATS, e.g. a SAR mission, as follows:

ALTRV: for a flight operated in accordance with an altitude reservation;

ATFMX: for a flight approved for exemption from ATFM measures by the appropriate ATS authority;

FFR: for fire-fighting;

FLTCK: for a flight check for calibration of NAVAIDS;

HAZMAT: for a flight carrying hazardous material;

HEAD: for a flight with Head of State status;

HOSP: for a medical flight declared by medical authorities;

HUM: for a flight operating on a humanitarian mission;

MARSA: for a flight for which a military entity assumes responsibility for separation of military aircraft;

MEDEVAC: for a life critical medical emergency evacuation;

NONRVSM: for a non-RVSM capable flight intending to operate in RVSM airspace;

SAR: for a flight engaged in a search and rescue mission; and

STATE: for a flight engaged in military, customs or police services.

Other reasons for special handling by ATS shall be denoted under the designator “RMK/”.

PBN/ Indication of RNAV and/or RNP capabilities. Include as many of the descriptors below as apply to the flight, up to a maximum of eight entries, i.e. not more than 16 characters.

RNAV SPECIFICATIONS	
A1	RNAV 10 (RNP 10)
B1	RNAV 5 all permitted sensors
B2	RNAV 5 GNSS
B3	RNAV 5 DME/DME
B4	RNAV 5 VOR/DME
B5	RNAV 5 INS or IRS
B6	RNAV 5 LORAN C
C1	RNAV 2 all permitted sensors
C2	RNAV 2 GNSS
C3	RNAV 2 DME/DME
C4	RNAV 2 DME/DME/IRU
D1	RNAV 1 all permitted sensors
D2	RNAV 1 GNSS
D3	RNAV 1 DME/DME
D4	RNAV 1 DME/DME/IRU

RNP SPECIFICATIONS	
L1	RNP 4
O1	Basic RNP 1 all permitted sensors
O2	Basic RNP 1 GNSS
O3	Basic RNP 1 DME/DME
O4	Basic RNP 1 DME/DME/IRU
S1	RNP APCH
S2	RNP APCH with BARO-VNAV
T1	RNP AR APCH with RF (special authorization required)
T2	RNP AR APCH without RF (special authorization required)

Combinations of alphanumeric characters not indicated above are reserved.

NAV/ Significant data related to navigation equipment other than specified in PBN/, as required by the appropriate ATS authority. Indicate GNSS augmentation under this indicator, with a space between two or more methods of augmentation, e.g. NAV/GBAS SBAS.

COM/ Indicate communications applications or capabilities not specified in Item 10(a).

DAT/ Indicate data applications or capabilities not specified in 10(a).

SUR/ Include surveillance applications or capabilities not specified in Item 10(b).

DEP/ Name and location of departure aerodrome, if “ZZZZ” is inserted in Item 13, or the ATS unit from which supplementary flight plan data can be obtained, if “AFIL” (airfile) is inserted in Item 13. For aerodromes not listed in the relevant AIP, indicate location as follows:

With four figures describing latitude in degrees and tens and units of minutes followed by “N” (North) or “S” (South), followed by five figures describing longitude in degrees and tens and units of minutes, followed by “E” (East) or “W” (West). Make up the correct number of figures, where necessary, by insertion of zeros, e.g. 4620N07805W (11 characters); OR

Bearing and distance from the nearest significant point, as follows:

The identification of the significant point followed by the bearing from the point in the form of three figures giving degrees magnetic, followed by the distance from the point in the form of three figures expressing nautical miles. In areas of high latitude where it is determined by the appropriate authority that reference to degrees magnetic is impractical, degrees true may be used. Make up the correct number of figures, where necessary, by insertion of zeros, e.g. a point of 180° magnetic at a distance of 40 NM from VOR “DUB” should be expressed as DUB180040; OR

The first point of the route (name or LAT/LONG) or the marker radio beacon, if the aircraft has not taken off from an aerodrome.

DEST/ Name and location of the destination aerodrome, if “ZZZZ” is inserted in Item 16. For aerodromes not listed in the relevant AIP, indicate location in LAT/LONG or bearing and distance from the nearest significant point, as described under DEP/, above.

DOF/ The date of flight departure in a six-figure format (YYMMDD, where YY equals the year, MM equals the month and DD equals the day).

REG/ The nationality or common mark and registration mark of the aircraft, if different from the aircraft identification in Item 7.

EET/ Significant points or FIR boundary designators and accumulated EETs from takeoff to such points or FIR boundaries, when so prescribed on the basis of regional air navigation agreements, or by the appropriate ATS authority.

Examples: EET/CAP0745 XYZ0830/
EET/EINN0204

SEL/ SELCAL Code, for aircraft so equipped.

TYP/ Type(s) of aircraft, preceded if necessary without a space by number(s) of aircraft and separated by one space, if “ZZZZ” is inserted in Item 9.

Example: TYP/2F15 5F5 3B2

DLE/ En-route delay or holding, insert the significant point(s) on the route where a delay is planned to occur, followed

by the length of delay using four-figure time in hours and minutes (hhmm).

Example: DLE/MDG0030

OPR/ ICAO designator or name of the aircraft operating agency, if different from the aircraft identification in Item 7.

ORGN/ The originator's eight-letter AFTN address or other appropriate contact details, in cases where the originator of the flight plan may not be readily identified, as required by the appropriate ATS authority.

NOTE: In some areas, flight plan reception centres may insert the "ORGN/" identifier and originator's AFTN address automatically.

PER/ Aircraft performance data, indicated by a single letter as specified in the *Procedures for Air Navigation Services—Aircraft Operations* (PANS-OPS, ICAO Doc 8168), *Volume I — Flight Procedures*, if so prescribed by the appropriate ATS authority.

ALTN/ Name of destination alternate aerodrome(s), if "ZZZZ" is inserted in Item 16. For aerodromes not listed in the relevant AIP, indicate location in LAT/LONG or bearing and distance from the nearest significant point, as described in DEP/, above.

RALT/ ICAO four-letter indicator(s) for en-route alternate(s), as specified in ICAO Doc 7910—*Location Indicators*, or name(s) of en-route alternate aerodrome(s), if no indicator is allocated. For aerodromes not listed in the relevant AIP, indicate location in LAT/LONG or bearing and distance from the nearest significant point, as described in DEP/, above.

TALT/ ICAO four-letter indicator(s) for takeoff alternate, as specified in ICAO Doc 7910—*Location Indicators*, or name of takeoff alternate aerodrome, if no indicator is allocated. For aerodromes not listed in the relevant AIP, indicate location in LAT/LONG or bearing and distance from the nearest significant point, as described in DEP/, above.

RIF/ The route details to the revised destination aerodrome, following by the ICAO four-letter location indicator of the aerodrome. The revised route is subject to reclearance in flight.

Examples: RIF/DTA HEC KLAX

RIF/ESP G94 CLA YPPH

RMK/ Any other plain-language remarks when required by the appropriate ATS authority or deemed necessary, e.g. TCAS- equipped—ICAO only.

3.16.9 Item 19: Supplementary Information

3.16.9.1 Endurance

AFTER "E/"

INSERT a four-figure group giving the fuel endurance in hours and minutes.

3.16.9.2 Persons On Board

AFTER "P/"

INSERT the total number of persons (passengers and crew) on board, when required by the appropriate ATS authority. INSERT "TBN" (to be notified) if the total number of persons is not known at the time of filing.

3.16.9.3 Emergency and Survival Equipment

R/(RADIO)

CROSS OUT indicator "U" if UHF on frequency 243.0 MHz is not available. CROSS OUT indicator "V" if VHF on frequency 121.5 MHz is not available. CROSS OUT indicator "E" if an ELT is not available. Canadian use only: ELT categories should be entered in the "ELT TYPE" box on the flight plan and flight itinerary forms. These categories (types) are described in SAR 3.2.

S/(SURVIVAL EQUIPMENT)

CROSS OUT all indicators if survival equipment is not carried. CROSS OUT indicator "P" if polar survival equipment is not carried. CROSS OUT indicator "D" if desert survival equipment is not carried. CROSS OUT indicator "M" if maritime survival equipment is not carried. CROSS OUT indicator "J" if jungle survival equipment is not carried.

J/(JACKETS)

CROSS OUT all indicators if life jackets are not carried. CROSS OUT indicator "L" if life jackets are not equipped with lights. CROSS OUT indicator "F" if life jackets are not equipped with fluorescein. CROSS OUT indicator "U" or "V" or both (as in R/, above) to indicate radio capability of jackets, if any.

D/(DINGHIES) (NUMBER)

CROSS OUT indicators "D" and "C" if no dinghies are carried, or INSERT number of dinghies carried; and

(CAPACITY)

INSERT total capacity, in persons, of all dinghies carried; and

(COVER)

CROSS OUT indicator “C” if dinghies are not covered; and

(COLOUR)

INSERT colour of dinghies, if carried.

A/(AIRCRAFT COLOUR AND MARKINGS)

INSERT colour of aircraft and significant markings. Canadian use only: Tick appropriate box for wheels, skis, etc.

N/(REMARKS)

CROSS OUT indicator “N” if no remarks, or INDICATE any other survival equipment carried and any other remarks regarding survival equipment. INDICATE if aircraft is equipped with a ballistic parachute system.

ARRIVAL REPORT

Canadian use only: Fill in the required information.

AIRCRAFT

Canadian use only: Indicate the aircraft owner, person(s) or company to be notified if SAR action is initiated.

C/(PILOT)

INSERT name of pilot-in-command.

Canadian use only: INSERT pilot’s licence number.

Figure 3.1—Composite IFR/VFR/IFR Flight Itinerary

The form is titled 'CANADIAN FLIGHT PLAN / ITINÉRAIRE DE VOL CANADIEN' and 'ICAO FLIGHT PLAN / PLAN DE VOL OACI'. It contains the following sections:

- Priority:** FF
- Message Type:** (FPL)
- Aircraft Identification:** C, F, A, B, C
- Flight Rules:** Y
- Departure Aerodrome:** CYXE
- Time:** 0900
- Altitude:** 306
- Destination:** CYP, A
- Endurance:** 0500
- Survival Equipment:** S, P, R, L, V, E, A, P
- Aircraft Colour and Markings:** RED ON WHITE
- Pilot:** S. RENNICK, Licence No. 23456

Explanation of Figure 3.1—Composite IFR/VFR/IFR Flight Itinerary

Item 7:
Aircraft identification

Item 8:
“Y” indicates that the flight will be initially operated under the IFR, followed by one or more subsequent changes of flight rules.

“F” indicates that it is a flight itinerary.

Item 9:
Aircraft is a Beechcraft 100.

Item 10:
“S” indicates standard COM/NAV equipment of VHF, RTF, VOR and ILS.

“D” indicates DME equipped.

“C” indicates transponder Mode A (four digits—4096 codes) and Mode C.

Item 13:
Departure aerodrome is Saskatoon at 0900 UTC.

RAC

Item 15:

Speed is 170 kt.

Altitude is 5 000 ft.

Route is V306 to the Lumsden VOR.

“VFR” indicates a change in flight rules to VFR at Lumsden.

“JQ3” indicates direct flight from Lumsden to the aerodrome at Carlyle.

“(5200)” indicates a stopover at Carlyle in hours and minutes.

Second “JQ3” indicates there will be a stopover at Carlyle.

“VLN” indicates direct flight from Carlyle to the Lumsden VOR.

“N0170A060IFR” indicates that the altitude is changed to 6 000 ft and the next leg will be IFR (although the speed did not change; if there is a change to either speed or altitude, both have to be indicated).

Route is V306 from Lumsden to the Saskatoon VOR.

Item 16:

Destination aerodrome is Saskatoon.

EET from takeoff to landing at Saskatoon is 2 days and 6 hours (this includes the flight time and the stopover time at Carlyle).

SAR time of 6 hours indicates the pilot’s desire to have SAR action initiated at 6 hours after the total EET of the trip; in other words, 2 days and 12 hours after takeoff from Saskatoon (if there is no entry in this block the SAR activation time would be 24 hours after the EET).

Alternate aerodrome is Prince Albert.

Item 18:

Although no other information is provided in this example, this section is for listing any other information as previously described in RAC 3.0.

Item 19:

Flying time endurance is 5 hr. There are two people in the aircraft (including crew).

“X” over “U” indicates there is no UHF emergency radio.

Unaltered “V” indicates there is VHF emergency radio.

Unaltered “E” under ELT indicates there is an emergency locator transmitter.

“AP” under ELT TYPE indicates an automatic portable ELT.

Unaltered “P” under POLAR indicates polar equipment is carried.

Unaltered “J” and “L” indicates that life jackets with lights are carried.

“Xs” on “D” and “C” indicate there are no dinghies.

Aircraft colour and markings are self explanatory.

“X” on “N” indicates there are no additional remarks on survival gear.

Example indicates closure with Saskatoon tower.

Contact name and number is self explanatory.

Pilot’s licence number assists SAR specialists in their search.

Figure 3.2—IFR Flight Plan (ICAO)

NAV CANADA		CANADIAN FLIGHT PLAN / ITINERARY PLAN DE VOL / ITINÉRAIRE DE VOL CANADIEN		ICAO FLIGHT PLAN PLAN DE VOL OACI	
PRIORITY / PRIORITÉ FF		ADDRESSEE(S) / DESTINATAIRE(S)			
FILING TIME / HEURE DE D. PT		ORIGINATOR / EXP. DITEUR			
SPECIFIC IDENTIFICATION OF ADDRESSEE(S) AND/OR ORIGINATOR / IDENTIFICATION PRÉCISE DU(DES) DESTINATAIRE(S) ET/OU DE L'EXP. DITEUR					
3 MESSAGE TYPE TYPE DE MESSAGE FPL	7 AIRCRAFT IDENTIFICATION IDENTIFICATION DE L'AÉRONEF A, C, A, 8, S, 6	8 FLIGHT RULES RÈGLES DE VOL I	TYPE OF FLIGHT TYPE DE VOL S		
9 NUMBER / NOMBRE B, 7, 4, 7	TYPE OF AIRCRAFT / TYPE D'AÉRONEF B, 7, 4, 7	WAKE TURBULENCE CAT. CAT. DE TURBULENCE DE SILLAGE H	EQUIPMENT / ÉQUIPEMENT S X / S		
13 DEPARTURE AERODROME / AÉRODROME DE D. PART C, Y, U, L		15 CRUISING SPEED VITESSE DE CROISIÈRE N, O, 4, 3, 8			
16 DESTINATION AERODROME / AÉRODROME DE DESTINATION E, G, L, L		18 OTHER INFORMATION / RENSEIGNEMENTS DIVERS EET / YE 00137 YVR015 SCR D 0 20 30W 0234 40W 0312 EEGX 0350 20W 0426 10W 006 BEL 0526 REG / CGACA SEL / EHFk			
19 ENDURANCE / AUTONOMIE E / 0, 9, 0, 0		EMERGENCY RADIO / RADIO DE SECOURS R / U V E		ELT TYPE E A F	
AIRCRAFT COLOUR AND MARKINGS / COULEUR ET MARQUES DE L'AÉRONEF WHITE		REMARKS / REMARQUES AN ARRIVAL REPORT WILL BE FILED WITH - UN COMPTE RENDU D'ARRIVÉE SERA NOTIFIÉ A KINGSTON FSS G. RENNICK 613-878-4373			
PILOT IN COMMAND / PILOTE COMMANDANT DE BORD S. RENNICK		PILOT'S LICENCE No./N° DE LICENCE DU PILOTE 123456			
FILED BY / DÉPOSÉ PAR		SPACE RESERVED FOR ADDITIONAL REQUIREMENTS / ESPACE R. SERV. / DES FINS SUPPL. / MENTAIRES			

Figure 3.3—VFR Flight Plan

NAV CANADA		CANADIAN FLIGHT PLAN / ITINERARY PLAN DE VOL / ITINÉRAIRE DE VOL CANADIEN		ICAO FLIGHT PLAN PLAN DE VOL OACI	
PRIORITY / PRIORITÉ FF		ADDRESSEE(S) / DESTINATAIRE(S)			
FILING TIME / HEURE DE DÉPÔT		ORIGINATOR / EXPÉDITEUR			
SPECIFIC IDENTIFICATION OF ADDRESSEE(S) AND/OR ORIGINATOR / IDENTIFICATION PRÉCISE DU(DES) DESTINATAIRE(S) ET/OU DE L'EXPÉDITEUR					
3 MESSAGE TYPE TYPE DE MESSAGE FPL	7 AIRCRAFT IDENTIFICATION IDENTIFICATION DE L'AÉRONEF C, F, A, B, C, 1	8 FLIGHT RULES RÈGLES DE VOL V	TYPE OF FLIGHT TYPE DE VOL S / C		
9 NUMBER / NOMBRE C, 1, 7, 2	TYPE OF AIRCRAFT / TYPE D'AÉRONEF C, 1, 7, 2	WAKE TURBULENCE CAT. CAT. DE TURBULENCE DE SILLAGE 0, 9, 0, 0	EQUIPMENT / ÉQUIPEMENT S / C		
13 DEPARTURE AERODROME / AÉRODROME DE DÉPART C, Y, O, W		15 CRUISING SPEED VITESSE DE CROISIÈRE N, O, 1, 2, 0			
16 DESTINATION AERODROME / AÉRODROME DE DESTINATION C, Y, G, K		18 OTHER INFORMATION / RENSEIGNEMENTS DIVERS EET / YE 00137 YVR015 SCR D 0 20 30W 0234 40W 0312 EEGX 0350 20W 0426 10W 006 BEL 0526 REG / CGACA SEL / EHFk			
19 ENDURANCE / AUTONOMIE E / 0, 3, 0, 0		EMERGENCY RADIO / RADIO DE SECOURS R / U V E		ELT TYPE E A F	
AIRCRAFT COLOUR AND MARKINGS / COULEUR ET MARQUES DE L'AÉRONEF RED ON WHITE		REMARKS / REMARQUES AN ARRIVAL REPORT WILL BE FILED WITH - UN COMPTE RENDU D'ARRIVÉE SERA NOTIFIÉ A KINGSTON FSS G. RENNICK 613-878-4373			
PILOT IN COMMAND / PILOTE COMMANDANT DE BORD S. RENNICK		PILOT'S LICENCE No./N° DE LICENCE DU PILOTE 123456			
FILED BY / DÉPOSÉ PAR		SPACE RESERVED FOR ADDITIONAL REQUIREMENTS / ESPACE R. SERV. / DES FINS SUPPL. / MENTAIRES			

RAC

4.0 AIRPORT OPERATIONS

4.1 GENERAL

Pilots must be particularly alert when operating in the vicinity of an airport. Increased traffic congestion, aircraft in climb and descent attitudes, and pilots preoccupied with cockpit duties, are some of the factors that increase the accident potential near airports. The situation is further compounded when the weather only just meets VFR requirements.

Several operators have, for some time, been using their landing lights when flying at lower altitudes and within terminal areas, both during daylight hours and at night. Pilot comment has confirmed that the use of landing lights greatly increases the probability of the aircraft being seen. An important side benefit for improved safety is that birds appear to see aircraft showing lights in time to take avoiding action. In view of this, it is recommended that, when so equipped, all aircraft use landing lights during the takeoff and landing phases and when flying below 2 000 ft AGL within terminal areas and aerodrome traffic patterns.

ATC towers equipped with radar have the capability of providing an increased level of service to the aviation community. The Class of airspace determines the controller's responsibilities vis-à-vis separation between IFR and VFR aircraft, and between VFR and VFR aircraft. Control staff in certain towers will be able to assist aircraft in establishing visual separation through the provision of radar vectors, radar monitoring and altitude assignments. Use of the radar will also result in more efficient control of VFR aircraft.

While aircraft shall not be operated at speeds greater than 200 kt below 3 000 ft AGL and within 10 NM of a controlled aerodrome (CAR 602.32), there is no mandatory speed restriction when operating in the vicinity of an uncontrolled aerodrome. As traffic levels at some of these aerodromes may be high from time to time, the risk of a possible mid-air collision is somewhat elevated during these periods. For this reason, it is recommended that pilots reduce their aircraft speed to the maximum extent possible when operating below 3 000 ft AGL and within 10 NM of an uncontrolled aerodrome.

Incidents have occurred, when aircraft are being operated VFR within control zones, when the flight visibility is less than three miles due to local smoke, haze, rain, snow, fog or other condition. CAR 602.114 requires a minimum of three miles ground visibility for VFR flight within a control zone. This visibility is, of course, taken by a person on the ground and does not preclude the possibility that the visibility aloft may be less. Good airmanship requires that a pilot encountering less than three miles flight visibility within a control zone will either:

- (a) take action to avoid the area of reduced visibility; or
- (b) remain clear of the area of reduced visibility and request a special VFR clearance from ATC.

Pilots shall maintain a listening watch on the appropriate tower frequency while under control of the tower. Whenever possible, requests for radio checks and taxi instructions should be made on the appropriate ground control frequency. After establishing initial contact with the control tower, pilots will be advised of any frequency changes required.

4.1.1 Wake Turbulence

Wake turbulence has its greatest impact on departure and arrival procedures; however, pilots should not assume that it will only be encountered in the vicinity of aerodromes. Caution should be exercised whenever a flight is conducted anywhere behind and less than 1 000 ft below a large aircraft.

Radar Departures

Controllers generally apply the following radar separation minima between a preceding IFR/VFR aircraft and an aircraft vectored directly behind it and at less than 1 000 ft below:

Heavy behind a Heavy:	4 mi.
Light behind a Heavy:	6 mi.
Medium behind a Heavy:	5 mi.
Light behind a Medium:	4 mi.

Non-Radar Departures

Controllers will apply a two-minute separation interval to any aircraft that takes off into the wake of a known heavy aircraft if:

- (a) the aircraft concerned commences the takeoff from the threshold of the same runway; or
- (b) any following aircraft departs from the threshold of a parallel runway that is located less than 2 500 ft away from the runway used by the preceding heavy aircraft.

NOTE: ATC does not apply this two-minute spacing interval between a light following a medium aircraft in the above circumstances, but will issue wake turbulence advisories to light aircraft. Controllers will apply a three-minute separation interval to any aircraft that takes off into the wake of a known heavy aircraft, or a light aircraft that takes off into the wake of a known medium aircraft if:

- (a) the following aircraft starts its takeoff roll from an intersection or from a point further along the runway than the preceding aircraft; or
- (b) the controller has reason to believe that the following aircraft will require more runway length for takeoff than the preceding aircraft.

ATC will also apply separation intervals of up to three minutes when the projected flight paths of any following aircraft will cross that of a preceding heavy aircraft.

In spite of these measures, ATC cannot guarantee that wake turbulence will not be encountered.

Pilot Waivers

ATC tower controllers are required to advise pilots whenever a requested take-off clearance is denied solely because of wake turbulence requirements. The intention of this advisory is to make pilots aware of the reason for the clearance denial so that they may consider waiving the wake turbulence requirement. To aid in the pilot's decision, the tower controller will advise the type and position of the wake-creating aircraft. The following phraseologies will be used by the controller in response to a request for take-off clearance when wake turbulence is a consideration:

Tower: *NEGATIVE, HOLD SHORT WAKE TURBULENCE. HEAVY BOEING 747, ROTATING AT 6 000 FT;* or

Tower: *LINE UP AND WAIT, WAKE TURBULENCE, HEAVY DC10 AIRBORNE AT 2 MI.*

Pilots are reminded that there are some circumstances where wake turbulence separation cannot be waived.

There may be departure situations, such as with a steady crosswind component, where the full wake turbulence separation minima is not required. The pilot is in the best position to make an assessment of the need for wake turbulence separation. Although controllers are not permitted to initiate waivers to wake turbulence separation minima, they will issue takeoff clearance to pilots who have waived wake turbulence requirements on their own initiative, with the following exceptions:

- (a) a light or medium aircraft taking off behind a heavy aircraft and takeoff is started from an intersection or a point significantly further along the runway, in the direction of takeoff; or
- (b) a light or medium aircraft departing after a heavy aircraft takes off or makes a low or missed approach in the opposite direction on the same runway; or
- (c) a light or medium aircraft departing after a heavy aircraft makes a low or missed approach in the same direction on the same runway.

A pilot-initiated waiver for a VFR departure indicates to the controller that the pilot accepts responsibility for wake turbulence separation. The controller will still issue a wake turbulence cautionary with the takeoff clearance. Controllers are responsible for ensuring wake turbulence minima are met for IFR departures. More information on wake turbulence can be found in AIR 2.9.

4.1.2 Noise Abatement

Pilots and operators must conform to the applicable provisions of CAR 602.105—*Noise Operating Criteria*, and CAR 602.106—*Noise Restricted Runways* (see RAC Annex) and the applicable noise abatement procedures published in the CAP.

Noise operating restrictions may be applied at any aerodrome where there is an identified requirement. When applied at an aerodrome, the procedures and restrictions will be set out in the CFS, and shall include procedures and requirements relating to:

- (a) preferential runways;
- (b) minimum noise routes;
- (c) hours when aircraft operations are prohibited or restricted;
- (d) arrival procedures;
- (e) departure procedures;
- (f) duration of flights;
- (g) the prohibition or restriction of training flights;
- (h) VFR or visual approaches;
- (i) simulated approach procedures; and
- (j) the minimum altitude for the operation of aircraft in the vicinity of the aerodrome.

Transport Canada recognizes the need for analysis and consultation in the implementation of proposed new or amended noise abatement procedures or restrictions at airports and aerodromes. A process has been developed that includes consultation with all concerned parties before new or amended noise abatement procedures or restrictions can be published in the CAP or the CFS. When the following checklist has been completed for the proposed noise abatement procedures or restrictions, and the resulting analysis has been completed and approved by Transport Canada, the noise abatement procedure or restriction will be published in the appropriate aeronautical publication.

1. Description of the problem
2. Proposed solution (including possible exceptions)
3. Alternatives (such as alternative procedures or land uses in the community)
4. Costs (such as revenue impact, direct and indirect costs to the community, airport operator and airport users)
5. Noise impacts of the proposed solution
6. Effects on aircraft emissions
7. Effect on current and future airport capacity
8. Implications of not proceeding with the proposal

9. Implementation issues (e.g. aircraft technology, availability of replacement aircraft, ground facilities)
10. Impact on the aviation system
11. Safety implications
12. Air traffic management
13. Fleet impact

A complete description of the process involved is available on the Internet at: <http://www.tc.gc.ca/eng/civilaviation/opssvs/managementservices-referencecentre-ac3-300-302-002-469.htm> >

4.1.3 Preferential Runway Assignments

At controlled airports, when selecting preferential runways for noise abatement or for other reasons, air traffic controllers consider the runway condition, the effective crosswind component and the effective tailwind component.

The maximum effective crosswind component considered in determining runway selection is 25 kt for arrivals and departures on DRY runways, and 15 kt on WET runways. The maximum effective tailwind component is 5 kt.

During consultation between NAV CANADA, aviation stakeholders and Transport Canada, it was decided that operations on the preferential runway should be allowed to continue when more than 25 percent of the runway is covered with a TRACE contaminant, provided:

1. the airport operator has issued an Aircraft Movement Surface Condition Report (AMSCR) with a reported CRFI value in all segments of the runway greater than .40 or, if no AMSCR is received, an aircraft reports the braking action as being “good”; and
2. the maximum crosswind component, including gusts, is 15 kt or less.

In conditions where more than 25 percent of the preferential runway is covered with a TRACE contaminant, the runway most nearly aligned into the wind must be selected if:

1. the reported CRFI value in any segment of the runway is .40 or lower;
2. the crosswind component rises above 15 kt; or
3. a less than “good” braking action report is received from a pilot.

Although air traffic controllers may select a preferential runway in accordance with the foregoing criteria, pilots are not obligated to accept the runway for taking off or landing. It remains the pilot’s responsibility to decide if the assigned runway is operationally acceptable.

4.2 DEPARTURE PROCEDURES — CONTROLLED AIRPORTS

The following departure procedures are based on those applicable for an aerodrome that have all available services, and are listed in the order that they would be used. At smaller, less equipped airports, some services will be combined, e.g., the IFR clearance would be obtained from ground control where there is no separate clearance delivery frequency. Procedures solely applicable to IFR flight are briefly introduced here to establish their sequence. An elaboration thereof may be found in RAC 7.0, Instrument Flight Rules –Departure Procedures.

4.2.1 ATIS Broadcasts

If ATIS is available, a pilot should obtain the ATIS information prior to contacting either the ground control or tower. See RAC 1.3 for information on ATIS broadcasts.

4.2.2 Clearance Delivery

At locations where a “clearance delivery” frequency is listed, IFR departures should call on this frequency, prior to requesting taxi authorization, normally no more than 5 minutes prior to engine start. Where a clearance delivery frequency is not listed, the IFR clearance will normally be given after taxi authorization has been received. At several major aerodromes, departing VFR aircraft are required to contact “clearance delivery” before taxiing. These frequencies, where applicable, are found in the COMM Section of the CFS, for the appropriate aerodrome.

4.2.3 Radio Checks

If required, radio checks should, wherever possible, be requested on frequencies other than ATC frequencies (see COM 5.10 for readability scale). Normally, the establishment of two-way contact with an agency is sufficient to confirm that the radios are functioning properly.

4.2.4 Requests for Push-back or Power-back

Since controllers may not be in a position to see all obstructions an aircraft may encounter during push-back or power-back, clearance for this manoeuvre will not be issued by the tower. Pilots are cautioned that it is their responsibility to ensure that push-back or power-back can be accomplished safely prior to initiating aircraft movement.

4.2.5 Taxi Information

Taxi authorization should be requested on the ground control frequency. At locations where a “Clearance Delivery” frequency is listed, pilots should obtain their IFR clearance or a VFR code where applicable on this frequency prior to contacting ground control. Where no “Clearance Delivery” frequency is listed, the IFR clearance will normally be relayed

by ground control before or after taxi authorization has been issued. If no flight plan has been filed, the pilot should inform the tower “Clearance Delivery”, where available, or ground control of the nature of the flight on initial contact, such as “local VFR” or “proceeding VFR to (destination)”.

Pilot: *WINNIPEG GROUND, AZTEC GOLF JULIETT VICTOR HOTEL AT HANGAR NUMBER THREE, REQUEST TAXI-IFR EDMONTON EIGHT THOUSAND.*

Ground control: *AZTEC GOLF JULIETT VICTOR HOTEL, WINNIPEG GROUND, RUNWAY (number), WIND (in magnetic degrees and knots), ALTIMETER (four-digit group giving the altimeter in inches of mercury), TAXI VIA (runway or other specific point, route), (other information, such as traffic, airport conditions), (CRFI, RSC, or RVR when applicable), CLEARANCE ON REQUEST.*

Pilot: *GOLF JULIETT VICTOR HOTEL.*

Under no circumstances may a taxiing aircraft, whether proceeding to or from the active runway, taxi onto an active runway unless specifically authorized to do so (see RAC 4.2.6 and 4.2.7).

Upon receipt of a normal taxi authorization, a pilot is expected to proceed to the taxi-holding position for the runway assigned for takeoff. If a pilot is required to cross any runway while taxiing towards the departure runway, the ground or airport controller will issue a specific instruction to cross or hold short. If a specific authorization to cross was not received, pilots should hold short and request authorization to cross the runway. Pilots may be instructed to monitor the tower frequency while taxiing or until a specific point, or they may be advised to “contact tower holding short.” The term “holding short,” when used during the communications transfer, is considered as a location and does not require a readback.

To emphasize the protection of active runways and to enhance the prevention of runway incursions, ATC is required to obtain a readback of runway “hold” instructions. As a good operating practice, taxi authorizations that contain the instructions “hold” or “hold short” should be acknowledged by the pilot by providing a readback or repeating the hold point.

Examples of “hold” instructions that should be read back:

HOLD or HOLD ON (runway number or taxiway);

HOLD (direction) OF (runway number); or

HOLD SHORT OF (runway number, or taxiway).

Reminder: In order to reduce frequency congestion, readback of ATC taxi instructions, other than those listed above, is not required in accordance with CAR 602.31(1)(a); such instructions are simply acknowledged. With the increased simultaneous use of more than one runway, however, instructions to enter, cross, backtrack or line up on any runway should also, as a good operating practice, be acknowledged by a readback.

Example:

An aircraft is authorized to backtrack a runway to the holding bay and to report clear when in the holding bay.

Pilot: *CHARLIE FOXTROT ALFA BACKTRACKING RUNWAY TWO FIVE AND WILL REPORT IN THE HOLDING BAY.*

NOTE: To avoid causing clutter on controllers’ radar displays, pilots should adjust their transponders to “STANDBY” while taxiing and should not switch them to “ON” (or “NORMAL”) until immediately before takeoff.

The tower may instruct aircraft to “line up and wait.” Controllers will issue the name of the runway intersection or taxiway with the authorization if the line-up position is not at the threshold of the departing runway. When more than one entry point for the same runway is in use, ATC will also specify the runway entry point with the instruction to line up at the threshold.

4.2.6 Taxi Holding Positions

Authorization must be obtained before leaving a taxi holding position, or where a holding position marking is not visible or has not been established, before proceeding closer than 200 feet from the edge of the runway in use. At airports where it is not possible to comply with this provision, taxiing aircraft are to remain at a sufficient distance from the runway in use to ensure that a hazard is not created to arriving or departing aircraft.

4.2.7 Taxiway Holding Positions During IFR Operations

It is imperative that aircraft do not proceed beyond taxiway holding signs at controlled airports until cleared by ATC. Aircraft proceeding beyond the taxiway holding position signs may enter electronically sensitive areas and cause dangerous interference to the glide path or localizer signals. In Canada, holding position signs and holding position markings normally indicate the boundaries of electronically sensitive areas, and provide safe obstruction clearance distances from landing runways.

When an airport is operating under CAT II/III weather conditions or when its CAT II/III operations plan is in effect, pilots are to observe CAT II or III mandatory holding position signs. When an airport is not operating under CAT II/III weather conditions, or its low visibility operations plan is not in effect, pilots need not abide by the CAT II or III taxiway holding positions and are expected to taxi to the normal taxiway holding position markings, unless advised otherwise by ATC.

AGA 5.4.3 and 5.8.3 provide information on the taxiway holding position markings and signs.

At uncontrolled aerodromes, pilots awaiting takeoff should not proceed beyond the holding position signs or holding position markings until there is no risk of collision with aircraft landing, taxiing or departing.

4.2.8 Take-Off Clearance

When ready for takeoff, the pilot shall request a take-off clearance and should include the runway number. Upon receipt of the take-off clearance, the pilot shall acknowledge and take off without delay, or inform ATC if unable to do so.

Pilot: *TOWER, JULIETT GOLF TANGO READY FOR TAKEOFF, RUNWAY THREE SIX.*

Tower: *JULIETT GOLF TANGO, (any special information—hazards, obstructions, turn after takeoff, wind information if required, etc.), CLEARED FOR TAKEOFF RUNWAY THREE SIX (or JULIETT GOLF TANGO, FROM GOLF, CLEARED FOR TAKEOFF RUNWAY THREE SIX).*

Pilot: *JULIETT GOLF TANGO.*

Pilots may request to use the full length of the runway for takeoff at any time. If the runway is to be entered at an intersection and back tracking is required, pilots should indicate their intentions and obtain a clearance for the manoeuvre before entering the runway.

Pilots may request, or the controller may suggest, takeoff using only part of a runway. The pilot's request will be approved, provided noise abatement procedures, traffic, and other conditions permit. If suggested by the controller, the available length of the runway will be stated. It is the pilot's responsibility to ensure that the portion of the runway to be used will be adequate for the take-off run.

To expedite movement of airport traffic and achieve spacing between arriving and departing aircraft, take-off clearance may include the word "immediate." In such cases, "immediate" is used for the purpose of air traffic separation. On acceptance of the clearance, the aircraft shall taxi onto the runway and take off in one continuous movement. If, in the pilot's opinion, compliance would adversely affect their operations, the pilot should refuse the clearance. Pilots planning a static takeoff (i.e. a full stop after "lined up" on the runway), or a delay in takeoff, should indicate this when requesting take-off clearance. ATC will specify the name of the taxiway or intersection with the clearance for takeoff from a taxiway or runway intersection. When more than one entry point for the same runway is in use, ATC will also specify the threshold as the point from which the take-off run will commence for those aircraft departing from the threshold. A controller may not issue a clearance that would result in a deviation from established noise abatement procedures or wake turbulence separation minima.

4.2.9 Release from Tower Frequency

Unless otherwise advised by ATC, pilots do not require permission to change from tower frequency once clear of the control zone and should not request release from this frequency or report clear of the zone when there is considerable frequency congestion. When practicable, it is recommended that a pilot of a departing aircraft monitor tower frequency until 10 NM from the control zone.

VFR flights will not normally be released from tower frequency while operating within the control zone. Once outside control zones, or when departing from an uncontrolled aerodrome where an MF has been assigned, beyond the range within which MF procedures apply, pilots should monitor frequency 126.7 MHz.

4.2.10 Departure Procedures – NORDO Aircraft

Before proceeding to any portion of the manoeuvring area of a controlled airport, it is the pilot's responsibility to inform the control tower of his/her intentions and make appropriate arrangements for visual signals.

NOTE: Before operating within a control zone with Class C airspace, a clearance shall be obtained from the control tower.

A pilot should remain continuously alert for visual signals from the control tower.

An aircraft should remain at least 200 ft from the edge of any runway where holding position markings or signs are not visible or have not been established unless a clearance for takeoff or to cross the runway has been received.

When stopped by a red light, a pilot must wait for a further clearance before proceeding.

When ready for takeoff by day, the pilot may attract the attention of the airport controller by turning the aircraft toward the tower.

Acknowledgement of Visual Signals – pilot shall, where practical, acknowledge all clearances and instructions received by visual signals by day, by full movement of rudder or ailerons, whichever can be seen most easily (such movement should be repeated at least three times in succession), or by taxiing the aircraft to the authorized position.

4.2.11 Visual Signals

Visual signals used by the tower and their meanings are as follows:

TO AIRCRAFT ON THE GROUND:		
1	SERIES OF GREEN FLASHES	Cleared to taxi.
2	STEADY GREEN LIGHT	Cleared for takeoff.
3	SERIES OF RED FLASHES	Taxi clear of landing area in use.
4	STEADY RED LIGHT	Stop.
5	FLASHING WHITE LIGHT	Return to starting point on airport.
6	BLINKING RUNWAY LIGHTS	Advise vehicles and pedestrians to vacate runways immediately.

4.2.12 Departure Procedures – RONLY Aircraft

The procedures which apply to aircraft without radio also apply to aircraft equipped with receiver only, except that an airport controller may request the pilot to acknowledge a transmission in a specific manner. After the initial acknowledgement, no further acknowledgement, other than compliance with clearances and instructions, is necessary, unless otherwise requested by the controller.

4.3 TRAFFIC CIRCUITS — CONTROLLED AERODROMES

The following procedures apply to all aerodromes at which a control tower is in operation.

The traffic circuit consists of the crosswind leg, downwind leg, base leg and final approach leg.

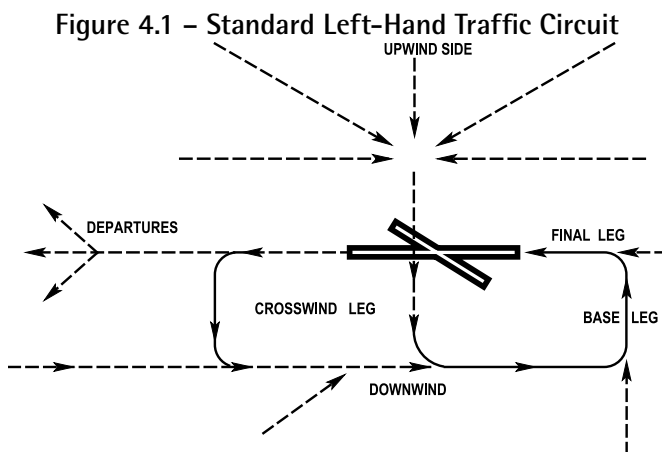

NOTES 1: Circuit normally flown at 1 000 feet AAE.

2: Where a right-hand circuit is required in accordance with CAR 602.96, the opposite of this diagram is applicable.

Entry to the circuit shall be made in such a manner so as to avoid cutting off other aircraft, conforming as closely as possible to the altitude (normally 1 000 ft AAE), speed and size of the circuit being flown by other traffic.

In order to increase safety by reducing the possibility of conflicting with departing traffic, aircraft approaching the active runway from the upwind side are to join the downwind leg abeam a point approximately midway between each end of the runway, taking into account aircraft performance, wind and/or runway length.

Pilots of NORDO and RONLY aircraft, who have made specific arrangements to operate within the control zone (RAC 4.4.5 and RAC 4.4.6), should approach the circuit from the upwind side, join crosswind at circuit height and, taking due account of other traffic, join the circuit on the downwind leg. Pilots are cautioned to remain clear of the approach and/or departure path of the active runway when joining the circuit (see Figure 4.1). Flights which are not in communication with the tower shall, at all times, be on the alert for visual signals. Pilots are reminded that below 3 000 feet AGL and within 10 NM of a controlled aerodrome, aircraft shall not be operated at speeds greater than 200 kt. However, where the minimum safe speed of the aircraft is greater than 200 kt, the aircraft may be operated at the minimum safe speed (CAR 602.32).

4.4 ARRIVAL PROCEDURES — CONTROLLED AIRPORTS

If ATIS is available, all arrivals should monitor this frequency to obtain the basic aerodrome information prior to contacting the tower. (See RAC 1.3 for ATIS information and refer to RAC 5.8 for arrival procedures in Class C airspace, other than a control zone.)

4.4.1 Initial Contact

Pilots must establish and maintain radio communications with the appropriate control tower prior to operating within any control zone served by an operational control tower. Also, if the control zone is Class B or C airspace, the appropriate clearance must be received from the controlling agency prior to entry.

When practical, it is recommended that the pilot make initial contact at least 5 minutes prior to requiring clearance or entering the zone.

RAC

4.4.2 Initial Clearance

On initial contact with the tower, unless the pilot advises receipt of ATIS, the airport controller will inform the pilot of runway in use, wind direction and speed, altimeter setting and any other pertinent information. Following this, the pilot will receive clearance to proceed, including any necessary restrictions. The shortest routing to the runway may be expected if traffic permits. Pilots of VFR aircraft should check the CFS (or a VTA chart if applicable) for special procedures at the time of flight planning.

When a pilot is given a clearance “to the circuit” by ATC, it is expected that the aircraft will join the circuit on the downwind leg at circuit height. Depending on the direction of approach to the airport and the runway in use, it may be necessary to proceed crosswind prior to joining the circuit on the downwind leg.

The ATC phraseology “cleared to the circuit” authorizes a pilot to make a right turn in order to join crosswind, or partial right turn to join a left-hand circuit provided that the right turn or partial right turn can be carried out safely.

A straight-in approach is an approach where an aircraft joins the traffic circuit on the final leg without having executed any other portion of the circuit.

When an aircraft is cleared for a right-hand approach while a left-hand circuit is in effect, it shall be flown so as to join the circuit on the right-hand downwind leg, or join directly into the right-hand base leg, as cleared by the airport controller.

Pilot: *KELOWNA TOWER, CESSNA FOXTROT ALFA BRAVO CHARLIE, ONE FIVE MILES NORTH, SIX THOUSAND FIVE HUNDRED FEET VFR, REQUEST LANDING INSTRUCTIONS.*

Tower: *CESSNA FOXTROT ALFA BRAVO CHARLIE, KELOWNA TOWER, RUNWAY (number), WIND (direction in degrees magnetic, speed in knots), ALTIMETER (4-digit group in inches), (other pertinent instructions or information if deemed necessary), CLEARED TO THE CIRCUIT or CLEARED TO LEFT BASE LEG or CLEARED STRAIGHT-IN APPROACH.*

Pilot: *ALFA BRAVO CHARLIE.*

When a pilot has received current landing information from the tower or the ATIS broadcast, initial clearance may be requested as follows:

Pilot: *VICTORIA TOWER, CESSNA FOXTROT ALFA BRAVO CHARLIE (aircraft position), ALTITUDE, CHECK LANDING INFORMATION (or) WITH INFORMATION (ATIS code). REQUEST CLEARANCE TO THE CIRCUIT (or other type of approach).*

Once established in the circuit as cleared, the pilot is to advise the tower accordingly.

Pilot: *TOWER, ALFA BRAVO CHARLIE DOWNWIND.*

Tower: *ALFA BRAVO CHARLIE NUMBER (approach sequence number). If not Number 1, the tower will give the type, position and colour if significant, of aircraft to follow and other instructions or information.*

Pilot: *ALFA BRAVO CHARLIE.*

Common ATC Phraseologies:

FOLLOW (aircraft type) NOW ON BASE LEG.

EXTEND DOWNWIND.

WIDEN APPROACH.

VFR Holding Procedures

When it is required by traffic, VFR flights may be asked to ORBIT visually over a geographic location, VFR checkpoint or call-up point (when these are published in the CFS or VTA charts) until they can be cleared to the airport. If the request is not acceptable, pilots should inform ATC and state their intentions.

Pilot: *TORONTO TOWER, CESSNA FOXTROT ALFA BRAVO CHARLIE, OVER PORT CREDIT AT THREE THOUSAND FIVE HUNDRED FEET WITH INFORMATION ROMEO.*

Tower: *CESSNA FOXTROT ALFA BRAVO CHARLIE, TORONTO TOWER, ORBIT THE FOUR STACKS, ANTICIPATE A FIVE MINUTE DELAY, TRAFFIC IS A CESSNA ONE SEVEN TWO OVER THE FOUR STACKS, LAST REPORTED AT TWO THOUSAND FEET.*

The pilot is expected to proceed to the FOUR STACKS, orbit within visual contact of the checkpoint and be prepared to proceed to the airport immediately upon receipt of a further clearance. Left turns are recommended as terrain and collision avoidance are the pilot’s responsibilities.

Tower: *ALFA BRAVO CHARLIE, REPORT LEFT BASE FOR RUNWAY TWO FOUR LEFT. CLEARED TO THE CIRCUIT.*

Pilot: *ALFA BRAVO CHARLIE DEPARTING THE FOUR STACKS AT THIS TIME, WILL REPORT LEFT BASE TO RUNWAY TWO FOUR LEFT; or*

Pilot: *ALFA BRAVO CHARLIE*

4.4.3 Landing Clearance

At controlled airports, a pilot must obtain landing clearance prior to landing. Normally, the airport controller will initiate landing clearance without having first received the request from the aircraft; however, should this not occur, the onus remains upon the pilot to request such clearance in sufficient time to accommodate the operating characteristics of the aircraft being flown. NORDO and RONLY aircraft should be considered as intending to land when they join and conform to the traffic circuit. Landing clearance will normally be given when an aircraft is on final approach. If landing clearance is not received, the pilot should, except in case of emergency, pull up and make another circuit.

Pilot: TOWER, ALFA BRAVO CHARLIE LANDING CLEARANCE RUNWAY TWO SIX.

Tower: ALFA BRAVO CHARLIE, CLEARED TO LAND RUNWAY TWO SIX.

Pilot: ALFA BRAVO CHARLIE.

Controllers may, on occasion, authorize ground traffic to cross the landing runway after a landing clearance has been issued. Any such authorization by ATC is given with the assurance that the runway will be clear of conflicting traffic at the time the arriving aircraft crosses the landing threshold. When it appears that the runway may not be clear for landing, the pilot will be advised to “CONTINUE APPROACH, POSSIBLE PULL-UP.” When a “pull-up” is necessary (before or after the landing clearance has been issued), the pilot shall abandon the approach and make another circuit.

Tower: ALFA BRAVO CHARLIE, TRAFFIC STILL ON RUNWAY, PULL UP AND GO AROUND.

Common ATC Phraseologies:

CAUTION, POSSIBLE TURBULENCE FROM LANDING (aircraft type and position).

MAKE LEFT/RIGHT THREE SIX ZERO.

MAKE FULL-STOP LANDING.

CONTACT TOWER/GROUND ON (frequency) WHEN OFF RUNWAY/NOW.

The “cleared for the option” procedure has been introduced to give a pilot the option to make a touch-and-go, low approach, missed approach, stop-and-go, or a full stop landing. This procedure will normally be used during light traffic conditions.

Pilot: TOWER, ALFA BRAVO CHARLIE, DOWNWIND RUNWAY TWO SEVEN, REQUEST THE OPTION.

Tower: ALFA BRAVO CHARLIE, CLEARED FOR THE OPTION RUNWAY TWO SEVEN.

A clearance for a multiple touch-and-go permits the pilot to perform more than one touch-and-go during a single pass along the runway without stopping. The procedure is intended for student pilots training with an instructor and will only be authorized during light traffic conditions.

Pilot: TOWER, ALFA BRAVO CHARLIE, DOWNWIND RUNWAY TWO SEVEN, REQUEST MULTIPLE TOUCH-AND-GO.

Tower: ALFA BRAVO CHARLIE, CLEARED MULTIPLE TOUCH-AND-GO, RUNWAY TWO SEVEN.

4.4.4 Taxiing

A pilot must obtain an ATC authorization to taxi on the manoeuvring area at a controlled airport. Unless otherwise instructed by the airport controller, aircraft are expected to continue in the landing direction to the nearest suitable taxiway, exit the runway without delay and obtain further authorization to taxi. No aircraft should exit a runway onto another runway unless instructed or authorized to do so by ATC. When required, ATC will provide the pilot with instructions for leaving the runway. These instructions will normally be given to the pilot prior to landing or during the landing roll. When an aircraft is instructed to exit onto another runway, the pilot must:

- (a) obtain further authorization to taxi; and
- (b) remain on tower frequency until clear of that runway or until communication is transferred to ground control.

After landing on a dead-end runway, the pilot will normally be given instructions to backtrack. In all cases, after leaving the runway, unless otherwise instructed by ATC, pilots should continue to taxi forward across the taxi holding position lines or to a point at least 200 ft from the edge of the runway where a taxi holding position line is not available. The aircraft is not considered clear of the runway until all parts of the aircraft are past the taxi holding position line or the 200-ft point. When clearing landing runways onto taxiways or other runways, pilots should exercise good airmanship by continuing to taxi well clear of the hold position while contacting ground control to obtain taxi clearance. This is to prevent aircraft from blocking a runway exit to following aircraft. If unable to establish contact with ground control, pilots should stop and not cross any runway without receiving ATC authorization.

Tower: *ALFA BRAVO CHARLIE (instructions for leaving runway), CONTACT GROUND (specific frequency).*

Towers will normally provide the aircraft down time only when requested by the pilot.

Normally, aircraft will not be changed to ground control until off the active runway or runways.

Tower: *ALFA BRAVO CHARLIE, TAXI TO (apron or parking area)(any special instructions such as routing, traffic, cautionary or warning regarding construction or repair on the manoeuvring areas).*

4.4.5 Arrival Procedures – NORDO Aircraft

Before operating into a controlled aerodrome, pilots shall contact the control tower, inform the tower of their intentions and make arrangements for clearance through visual signals.

NOTE: Before operating within a control zone with Class C airspace, a clearance shall be obtained from the control tower.

Pilots should remain continuously alert for visual signals from the control tower.

Traffic Circuit – The pilot should approach the traffic circuit from the upwind side of the runway, join crosswind at circuit height abeam a point approximately midway between each end of the runway and join the circuit on the downwind leg. While within the circuit the pilot should conform to the speed and size of the circuit, maintaining a separation from aircraft ahead so that a landing can be made without overtaking it. If it is necessary for a flight to cross the airport prior to joining crosswind, this should be done at least 500 feet above circuit height, and descent to circuit height should be made in the upwind area of the active runway.

Final Approach – Before turning on final approach, a pilot shall check for any aircraft on a straight-in approach.

Landing Clearance – Landing clearance will be given on final approach. If landing clearance is not received, the pilot shall, except in case of emergency, pull up and make another circuit. (Landing clearance may be withheld by the tower when there are preceding aircraft which have not landed or if the runway is occupied.)

Taxiing – No taxi clearance is required after landing, except to cross any runway or to taxi back to a turn-off point. When an aircraft's landing run carries it past the last available turn-off point, it should proceed to the end of the runway and taxi to one side, waiting there until instruction is received to taxi back to the nearest turn-off point.

4.4.6 Arrival Procedures – RONLY Aircraft

The procedures which apply to aircraft without radio also apply to aircraft equipped with receiver only, except that an airport controller may request the pilot to acknowledge a transmission in a specified manner. After initial acknowledgement, no further acknowledgement other than compliance with clearances and instructions is necessary, unless otherwise requested by the controller.

4.4.7 Visual Signals

Visual signals used by the tower and their meanings are as follows:

TO AIRCRAFT IN FLIGHT:		
1	STEADY GREEN LIGHT	Cleared to land.
2	STEADY RED LIGHT	Give way to other aircraft and continue circling.
3	SERIES OF GREEN FLASHES	Return for landing. (This shall be followed at the proper time by a steady green light.)
4	SERIES OF RED FLASHES	Airport unsafe; do not land.
5	THE FIRING OF A RED PYROTECHNICAL LIGHT (see NOTE)	Whether by day or night and notwithstanding previous instructions, means do not land for the time being.

NOTE: Military control towers only.

Acknowledgement of Visual Signals – A pilot shall, where practicable, acknowledge all clearances and instructions received by visual signals. Signals may be acknowledged as follows:

- (a) distinct rocking of aircraft in flight;
- (b) at night, by a single flash of a landing light.

4.4.8 Communications Failure – VFR

- (a) CAR 602.138 specifies that where there is a two-way radio communication failure between the controlling air traffic control unit and a VFR aircraft while operating in Class B, Class C or Class D airspace, the pilot-in-command shall:
 - (i) leave the airspace
 - (A) where the airspace is a control zone, by landing at the aerodrome for which the control zone is established, and
 - (B) in any other case, by the shortest route;
 - (ii) where the aircraft is equipped with a transponder, set the transponder to Code 7600; and
 - (iii) inform an air traffic control unit as soon as possible of the actions taken pursuant to (i).
- (b) Should the communications failure occur while operating outside of Class B, C, or D airspace precluding the pilot from obtaining the appropriate clearance to enter or establishing radio contact, and if no nearby suitable aerodrome is available, the pilot may enter the Class B, C or D airspace, continue under VFR, and shall carry out the remaining procedures listed in (a).

Should the communications failure occur and there is a suitable aerodrome nearby at which the pilot wishes to land, it is recommended that the pilot comply with the established NORDO arrival procedure outlined in RAC 4.4.5.

Pilots operating VFR in either Class E or G airspace may follow the procedures in (a) even though there is no intention to enter Class B, C, or D airspace.

4.4.9 Operations on Intersecting Runways

ATC procedures allow for sequential and/or simultaneous operations on intersecting runways. Their intent is to increase airport traffic capacity, thus reducing delays and saving fuel. These operations differ only in the controllers' application of ATC procedures; ATC advisories will specify the type of operation(s) in progress.

- (a) *Sequential Operations:* Sequential operations do not permit controllers to allow either an arriving aircraft to cross the arrival threshold or a departing aircraft to commence its takeoff roll until certain conditions are met.

For an arriving aircraft (Figure 4.2) the conditions are as follows:

- (i) the preceding departing aircraft has:
 - (A) passed the intersection, or
 - (B) is airborne and has turned to avoid any conflict;
- (ii) the preceding arriving aircraft has:
 - (A) passed the intersection, or
 - (B) completed its landing roll and will hold short of the intersection (i.e., stopped or at taxi speed), or
 - (C) completed its landing roll and turned off the runway.

Figure 4.2 – Arriving Aircraft

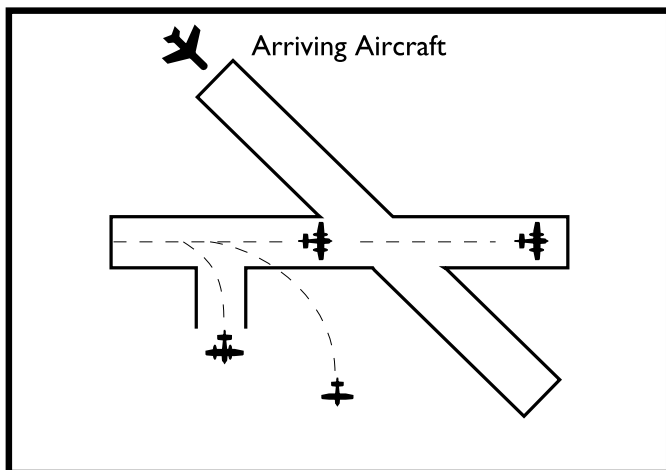

For a departing aircraft (Figure 4.3) the sequential conditions are listed below:

- (iii) the preceding departing aircraft
 - (A) has passed the intersection; or
 - (B) is airborne and has turned to avoid any conflict.

- (iv) the preceding arriving aircraft has
 - (A) passed the intersection;
 - (B) completed its landing roll and will hold short of the intersection (i.e., is stopped or at taxi speed); or
 - (C) completed its landing roll and turned off the runway.

Figure 4.3—Departing Aircraft

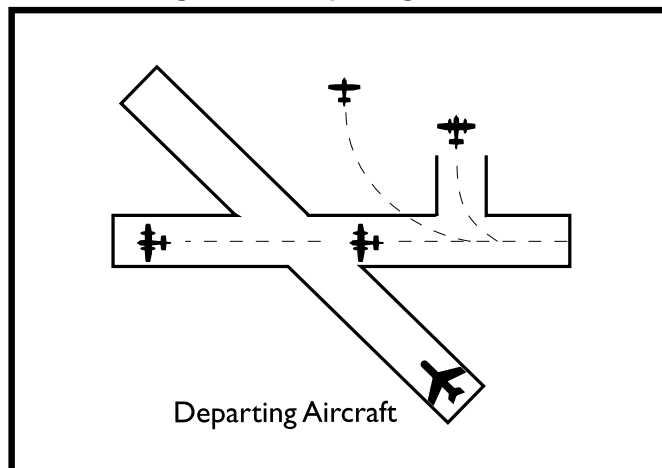

- (b) *Simultaneous Operations:* Simultaneous operations differ from sequential operations in the application of ATC procedures. The procedures for simultaneous use of intersecting runways are applied only between two arrivals or an arrival and a departure. Air traffic controllers will permit an arriving aircraft to cross the runway threshold or a departing aircraft to begin its takeoff roll without adhering to the conditions in RAC 4.4.9(a)(ii) (B) and RAC 4.4.9(a)(iv)(B) provided one of the aircraft has accepted a clearance to land and hold short of the intersecting runways (Figure 4.4). These operations are known as land and hold short operations (LAHSO).

General

LAHSO may be carried out under the following conditions:

- (i) the LDA, measured from the threshold or displaced threshold to 200 ft short of the nearest edge of the runway being intersected must be published in the CAP and in the CFS. ATC shall also broadcast LAHSO advisories, including LDAs, through an ATIS or voice advisory, well in advance of the final approach descent;
- (ii) the weather minima of a 1 000-ft ceiling and visibility of three statute miles are required. In specific cases, these criteria may be reduced by the Regional Director, Civil Aviation, but only with a written agreement between ATC and the operator;
- (iii) the reported braking action must be not less than good. The runway must be bare. (No snow, slush, ice, frost, or standing water is visible from the tower or reported by a competent person. In order to accommodate small accumulations of ice or snow at the runway edge during winter operations, only the centre 100 ft of the runway must be bare.);

- (iv) a tailwind of less than five knots is acceptable for normal LAHSO on both dry and wet runway operations. The maximum allowable crosswind component for dry runways is 25 kt and 15 kt for LAHSO. Controllers will not initiate or approve a request for LAHSO on any runway when crosswinds on that runway exceed the maximum;
- (v) ATC must include specific directions to hold short of an intersecting runway (e.g., “cleared to land Runway 27, hold short of Runway 36”). Pilots, in accepting the clearance, must read back “cleared to land Runway 27, hold short of Runway 36.” Having accepted the hold-short clearance, pilots are obligated to remain 200 ft short of the closest edge of the runway being intersected. If, for any reason, a pilot is unsure of being able to comply with a hold-short clearance, the pilot must advise ATC immediately of non-acceptance of the clearance; it is far better to be safe than sorry;
- (vi) the lines are the same as taxiway exit and holding markings, as described in AGA 5.4.3. These lines shall be located on the runway 90° to the hold-short runway centreline, 200 ft short of the nearest edge of the runway being intersected. Red and white mandatory instruction signs, illuminated for night LAHSO, shall be located at either end of the lines. More details on lines can be found in *Aerodrome Standards and Recommended Practices* (TP 312E); and
- (vii) for tactical ATC reasons, controllers may offer or approve a pilot request for the use of a dry runway for landing with a tailwind not exceeding ten knots. LAHSO will not be authorized on wet runways if the tailwinds are five knots or more.

NOTE: LAHSO are not authorized if thunderstorms, turbulence, wind shear or other conditions exist that would adversely affect the restricted aircraft’s ability to hold short after landing.

Figure 4.4—Aircraft with Hold-short Clearance

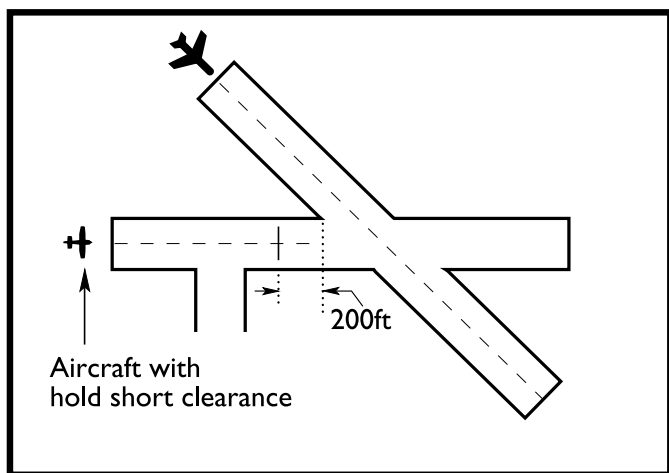

For simultaneous operations involving helicopters (Figure 4.5), if the arriving helicopter has a hold-short clearance, its point of landing is at least 700 ft from the centreline of the other runway.

Figure 4.5—Helicopter with Hold-short Clearance

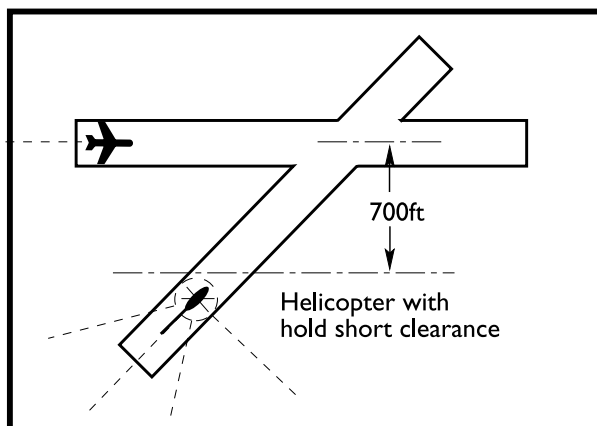

Wet Runways

The following conditions are applicable for wet runway operations:

- (i) no Group 6 aircraft shall be instructed to hold short of an intersecting runway;
- (ii) stopping distances for Group 1, 2 and 3 aircraft are increased by 15% (see Note); and
- (iii) the coefficient of friction on LAHSO runways must meet a minimum standard. The coefficient of friction will be measured in accordance with *Airport Pavement Evaluation—Surface Friction* (AK-68-35-000/TP 3716); only those runways with average coefficients of friction above 0.6 will be approved for wet runway LAHSO.

NOTE: Aircraft are categorized into groups requiring the following stopping distances:

	Dry Runway	Wet Runway
Group 1	1 650 ft	1 900 ft
Group 2	3 000 ft	3 500 ft
Group 3	4 500 ft	5 200 ft
Group 4	6 000 ft	6 000 ft
Group 5	8 000 ft	8 000 ft
Group 6	8 400 ft	8 400 ft

These stopping distances are based on ISA conditions for sea-level runways. For higher airport elevations, the distances are adjusted for pressure altitude. An aircraft’s grouping is such that its normal stopping distance is approximately 50% of the available stopping distance.

(c) General Provisions

1. All pilots will be advised that simultaneous LAHSO are in progress.
2. Controllers will issue appropriate traffic information.
3. Acceptance of a hold-short landing clearance indicates to the controller that a pilot is able to comply with the clearance. If for any reason a pilot elects to use the full length of a runway, or a different runway, the pilot should inform ATC on or before receipt of the hold-short landing clearance.

NOTE: During sequential and/or simultaneous operations, ATC procedures and pilot compliance with clearance conditions will ensure aircraft separation (i.e., spacing between aircraft). Notwithstanding this, conflicts between aircraft may occur, particularly at runway intersections, if a pilot does not comply with a clearance or is unable to comply as a result of unforeseen circumstances, such as missed approaches, misjudged landings, balked landings or brake failures. In these circumstances, ATC will endeavour to provide traffic advisories and/or instructions to assist pilots with collision avoidance.

4.4.10 High Intensity Runway Operations (HIRO)

Several of Canada's airports rank among North America's busiest in total aircraft movements. HIRO, as a concept, have evolved from procedures developed by high density terminals in North America and Europe. It is intended to increase operational efficiency and maximize the capacity at those airports where it is employed through the use of disciplined procedures applied by both pilots and air traffic controllers. HIRO is intended to minimize the occurrence of overshoots that result from slow-rolling and/or slow-clearing aircraft and offers the prospective of reducing delays overall, both on the ground and in the air. In its fullest application, HIRO enables ATC to apply minimum spacing to aircraft on final approach to achieve maximum runway utilization.

The tactical objective of HIRO is to minimize runway occupancy times (ROT) for both arriving and departing aircraft, consistent with both safety and passenger comfort. Effective participation in HIRO results when the pilot of an arriving aircraft exits the runway expeditiously, allowing the following arriving aircraft to cross the threshold with a minimum time interval. In the case of an arrival and a subsequent departure, the arriving pilot clears the runway in a minimum ROT, permitting a departure before the next arrival crosses the threshold. The air traffic controller's objective in HIRO is to optimize approach spacing. This can be best achieved when pilots reach and adhere to assigned speeds as soon as practicable.

Effective participation in HIRO is achieved by satisfying the following key elements.

Key elements for arrivals:

- The pilot's objective should be to achieve minimum ROT, within the normally accepted landing and braking performance of the aircraft, by targeting the earliest suitable exit point and applying the right deceleration rate so that the aircraft leaves the runway as expeditiously as possible at the nominated exit.
- The expected runway exit point to achieve minimum ROT should be nominated during approach briefing. It is better, in terms of ROT, to select an exit you know you can make, rather than choose an earlier one, miss it, and then roll slowly to the next available exit.
- Upon landing, pilots should exit the runway without delay.

High-speed exits have specific maximum design speeds. These speeds may be available through the appropriate airport authority. Key elements for departures:

- On receipt of a line-up clearance, pilots should ensure that they are able to line up on the runway as soon as the preceding aircraft has commenced its takeoff roll.
- ATC will expect aircraft to enter the runway at a suitable angle to quickly line-up on the centreline and, when possible, continue in to a rolling takeoff when cleared. Pilots should ensure that they are able to commence the takeoff roll immediately when a takeoff clearance is issued.
- Aircraft that need to enter the runway at right angles, to backtrack, or to use the full length of the runway will require extra time on the runway. Therefore, pilots should notify ATC before arriving at the holding area so that the controller can re-sequence departures to provide the extra time.
- Cockpit checks should be completed prior to line-up, and any checks requiring completion on the runway should be kept to a minimum. If extra time is required on the runway, ATC should be informed before the aircraft arrives at the holding area so that the controller can re-sequence departures to provide the extra time.

4.5 AIRCRAFT OPERATIONS— UNCONTROLLED AERODROMES

4.5.1 General

An uncontrolled aerodrome is an aerodrome without a control tower, or one where the tower is not in operation. There is no substitute for alertness while in the vicinity of an uncontrolled aerodrome. It is essential that pilots be aware of, and look out for, other traffic, and exchange traffic information when approaching or departing from an uncontrolled aerodrome, particularly since some aircraft may not have communication capability. To achieve the greatest degree of safety, it is essential that all radio-equipped aircraft monitor a common designated frequency, such as the published MF or ATF, and follow the reporting procedures specified for use in an MF area*, while operating on the manoeuvring area or flying within an MF area surrounding an uncontrolled aerodrome.

* *MF area* means an area in the vicinity of an uncontrolled aerodrome for which an MF has been designated. The area within which MF procedures apply at a particular aerodrome is defined in the Aerodrome/Facility Directory Section of the CFS, under the heading COMM. Normally, the MF area is a circle with a 5-NM radius capped at 3 000 ft AAE.

At uncontrolled aerodromes without a published MF or ATF, the common frequency for the broadcast of aircraft position and the intentions of pilots flying in the vicinity of that aerodrome is 123.2 MHz.

At aerodromes within an MF area, traffic information may be exchanged by communicating with an FSS, CARS, UNICOM operator, vehicle operator, or by a broadcast transmission. The VCS in conjunction with AAS is normally provided at aerodromes served by an FSS. Some uncontrolled aerodromes are indirectly served by an FSS through an RCO and may provide RAAS. As flight service specialists may be located some distance from an aerodrome, it is essential that they be kept fully informed of both aircraft and vehicle activity.

Other aerodromes are designated as having an ATF. At some aerodromes with a control tower or FSS, an ATF is designated for use when the air traffic facility is closed. If a radio-equipped vehicle is present at ATF aerodromes, pilots can contact the vehicle operator directly on the ATF to ascertain that no vehicle-aircraft conflict exists. Operators of such radio-equipped vehicles will also provide pilots with any other available information on runway status and presence of other aircraft or vehicles on the runway.

There are some remote airports where a voice generator module (VGM) connected to an AWOS (or LWIS) continuously broadcasts weather information. An AWOS (or LWIS) broadcasts weather information that may differ from the aviation routine weather report (METAR) or aviation selected special weather report (SPECI) issued for the location. There may also be significant differences between broadcasts only

a few minutes apart. Transport Canada recognizes that for any given site at any given time there can be only one official weather observation (METAR or SPECI), whether from a human observer or an automated station. As a result, it has been determined that although an AWOS (or LWIS) broadcast constitutes an additional source of accurate, up-to-the-minute weather information, it does not constitute an official weather observation (METAR or SPECI).

The wind and altimeter data obtained from an AWOS (or LWIS) via a VGM broadcast can be used to conduct an instrument approach. Therefore, at aerodromes where RAAS is provided and where AWOS (or LWIS) weather information is also available via a VGM broadcast, the wind and altimeter data may be omitted from the RAAS if the pilot indicates in the initial call to the FSS that the weather information has already been obtained from the VGM broadcast. To avoid unnecessary frequency changes and to assist in reducing frequency congestion, it is desirable that pilots acquire this weather information prior to entering either the MF or ATF area and inform the flight service specialist that they have the wind and altimeter information. On start-up at such an aerodrome, it would be desirable to listen to the VGM broadcast prior to taxiing.

The flight service specialist will advise pilots of below-minima conditions reported in the current official METAR or SPECI. This will ensure a common reference for pilots and ATS personnel since IFR or SVFR authorization would then be required to operate within the control zone. Pilots will also be advised of any other significant weather conditions reported in current METAR, SPECI, SIGMET, AIRMET or PIREP, as appropriate, which may affect the safety of the flight. The flight service specialist will provide, upon request, the complete current METAR or SPECI for the location.

4.5.2 Traffic Circuit Procedures — Uncontrolled Aerodromes

The following procedures apply to all aircraft operating at aerodromes where airport control service is not provided except those aircraft following a standard instrument approach procedure. For procedures that apply to aircraft on a standard instrument approach, refer to RAC 9.0. Prior to joining a traffic circuit, all pilots should announce their intentions (see RAC 4.5.6). All turns shall be to the left while operating in the circuit, unless a right-hand circuit has been specified in the CFS.

Pilots operating aircraft under IFR or VFR are expected to approach and land on the active runway. The active runway is a runway that other aircraft are using or are intending to use for the purpose of landing or taking off. Should it be necessary for aircraft to approach to, land on, or take off from a runway other than the active runway, it is expected that the appropriate communication between pilots and the ground station will take place to ensure there is no conflict with other traffic. Some pilots operating under VFR at many sites prefer

to give commercial IFR and larger type of aircraft priority. This practice, however, is a personal airmanship courtesy, and it should be noted that these aircraft do not establish any priority over other aircraft operating VFR at that aerodrome.

Figure 4.6—Standard Left-hand Circuit Pattern

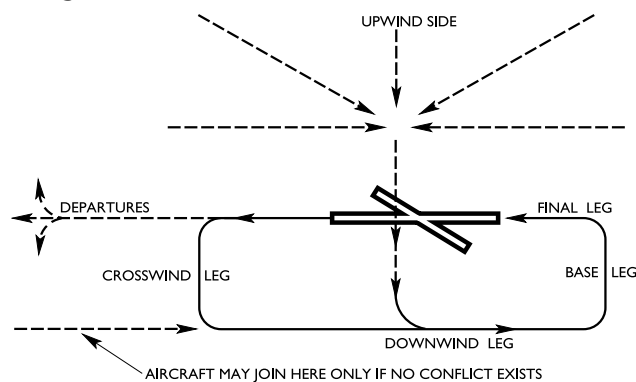

NOTES 1: The circuit is normally flown at 1 000 ft AAE.
2: If a right-hand circuit is required in accordance with CAR 602.96, the opposite of this diagram is applicable.

(a) Joining the Circuit

- (i) Landing and takeoff should be accomplished on or parallel to the runway most nearly aligned into the wind. However, the pilot has the final authority and responsibility for the safe operation of the aircraft and another runway may be used if it is determined to be necessary in the interest of safety.
- (ii) Unless otherwise specified or required by the applicable distance from cloud criteria, aircraft should approach the traffic circuit from the upwind side. Alternatively, once the pilot has ascertained without any doubt that there will be no conflict with other traffic entering the circuit or traffic established within the circuit, the pilot may also join the circuit on the downwind leg (Figure 4.6). When joining from the upwind side, plan the descent to cross the runway in level flight at 1 000 ft AAE or the published circuit altitude. Maintain that altitude until further descent is required for landing.
- (iii) If it is necessary for an aircraft to cross the airport before joining the circuit, it is recommended that the crossover be accomplished at least 500 ft above the circuit altitude.
- (iv) All descents should be made on the upwind side or well clear of the circuit pattern.
- (v) Aerodromes not within an MF area: Where no MF procedures are in effect, aircraft should approach the traffic circuit from the upwind side. Alternatively, once the pilot has ascertained without any doubt that there will be no conflict with other traffic entering the circuit or traffic established within the circuit, the pilot may join the circuit on the downwind leg (Figure 4.6).

(vi) Aerodromes within an MF area when airport advisory information is available: Aircraft may join the circuit pattern straight-in or at 45° to the downwind leg or straight-in to the base or final legs (Figure 4.1). Pilots should be alert for other VFR traffic entering the circuit at these positions and for IFR straight-in or circling approaches.

(vii) Aerodromes within an MF area when airport advisory information is not available: Aircraft should approach the traffic circuit from the upwind side. Alternatively, once the pilot has ascertained without any doubt that there will be no conflict with other traffic entering the circuit or traffic established within the circuit, the pilot may join the circuit on the downwind leg (Figure 4.6).

NOTE: Where an uncontrolled aerodrome lies within an MF area, the pilot must follow the MF reporting procedures set out in CARs 602.97 to 602.103 inclusive. (See RAC 4.5.4 and 4.5.7.)

(b) *Continuous Circuits:* Aircraft performing a series of circuits and landings should, after each takeoff, reach circuit altitude before joining the downwind leg.

(c) *Departing the Circuit or Airport:* Aircraft departing the circuit or airport should climb straight ahead on the runway heading until reaching the circuit traffic altitude before commencing a turn in any direction to an en route heading. Turns back toward the circuit or airport should not be initiated until at least 500 ft above the circuit altitude.

4.5.3 Helicopter Operations

Pilots of helicopters at uncontrolled aerodromes are urged to avoid air taxiing or low flying across runways and taxiway areas where risk of collision with unseen aircraft or vehicles exists.

In addition to maintaining a sharp look-out and practising good airmanship, generally, pilots should avoid ground or air taxiing and hovering where blown dust, sand or gravel could prove hazardous to other aircraft, or when debris could be blown onto paved surfaces.

4.5.4 Mandatory Frequency

Transport Canada has designated a Mandatory Frequency (MF) for use at selected uncontrolled aerodromes, or aerodromes that are uncontrolled between certain hours. Aircraft operating within the area in which the MF is applicable (MF area), on the ground or in the air, shall be equipped with a functioning radio capable of maintaining two-way communication. Reporting procedures shall be followed, as specified in CARs 602.97 to 602.103 inclusive. An MF area will be established at an aerodrome if the traffic volume and mix of aircraft traffic at that aerodrome is such that there would be a safety benefit derived from implementing MF procedures. There may or may not be a ground station in operation at the aerodrome for which the MF area has been established. When a ground station is



in operation, for example, an FSS, an RCO through which RAAS is provided, a CARS, or an Approach UNICOM, then all aircraft reports that are required for operating within, and prior to entering an MF area, shall be directed to the ground station. However, when the ground station is not in operation, then all aircraft reports that are required for operating within and prior to entering an MF area shall be broadcast. The MF will normally be the frequency of the ground station which provides the air traffic advisory services for the aerodrome. For the aerodromes with an MF, the specific frequency, distance and altitude within which MF procedures apply will be published in the CFS.

Examples

1. *MF—rdo 122.2 5 NM 3100 ASL*
2. *MF—UNICOM (AU) ltd hrs O/T tfc 122.75 5 NM 3100 ASL*

4.5.5 Aerodrome Traffic Frequency

An Aerodrome Traffic Frequency (ATF) is normally designated for active uncontrolled aerodromes that do not meet the criteria listed in RAC 4.5.4 for an MF. The ATF is established to ensure that all radio-equipped aircraft operating on the ground or within the area are listening on a common frequency and following common reporting procedures. The ATF will normally be the frequency of the UNICOM where one exists or 123.2 MHz where a UNICOM does not exist. Trained vehicle operators who possess a valid radiotelephone licence and authorized to do so, can communicate with pilots using two-way communication on the ATF and provide information such as:

- (a) position of vehicles on the manoeuvring area;
- (b) position of other aircraft on the manoeuvring area; and
- (c) runway condition, if known.

The specific frequency, distance and altitude within which use of the ATF is required will be published in the CFS.

Example: *ATF – tfc 123.2 5 NM 5500 ASL*

Personnel providing Approach UNICOM service, can also advise pilots on the ATF of the runway condition and position of vehicles or aircraft on the manoeuvring area.

NOTE: Pilots may be able to communicate with either the UNICOM or the vehicle operator if radio-equipped, and co-ordinate their arrival or departure while using normal vigilance to ensure safe operations. When communications cannot be established (no reply or NORDO) or the status of the runway is unknown, it is the pilot's responsibility to visually ascertain the runway condition before landing or taking off.

The designation of an ATF is not limited to aerodromes only. An ATF may also be designated for use in certain areas other than the area immediately surrounding an aerodrome, where VFR traffic activity is high, and there is a safety benefit to ensuring that all traffic monitor the same frequency. For example, an ATF area could be established along a frequently flown corridor between two uncontrolled aerodromes. All aircraft operating within the area, below a certain altitude, would be requested to monitor and report intentions on one frequency. When such an area is designated, it will be specified either in an Aviation Notice, or in the CFS.

4.5.6 Use of MF and ATF

When operating in accordance with VFR, or in accordance with IFR but in VMC, pilots have sole responsibility for seeing and avoiding other aircraft. Aural and visual alertness are required to enhance safety of flight in the vicinity of uncontrolled aerodromes. At uncontrolled aerodromes for which an MF or ATF has been designated, certain reports shall be made by all radio-equipped aircraft.

NOTE: Pilots operating VFR en route in uncontrolled airspace or VFR on an airway should continuously monitor 126.7 MHz when not communicating on the MF or ATF.

Reports on either the MF or ATF have three formats:

- (a) a directed transmission made to a ground station;
- (b) a directed transmission made to a vehicle operator on the ATF; or
- (c) a broadcast transmission that is not directed to any particular receiving station.

Whenever the CFS indicates that reports are to be made to a ground station, the initial transmission should be made to the station. To assist in reducing frequency congestion, pilots are encouraged to use the phrase "HAVE NUMBERS" on the initial call to a ground station (arrival or departure) to indicate that they have received runway, wind and altimeter information from the previous aerodrome advisory. When operating outside an MF area, and when frequency congestion prevents pilots from making their mandatory calls, it is their responsibility to remain clear of the MF area until contact can be established with the FSS. If operating inside an MF area, the pilot should continue as stated in previous radio transmissions.

Pilot: *FREDERICTON RADIO, PIPER FOXTROT X-RAY YANKEE ZULU. WE HAVE THE NUMBERS, SIX MILES SOUTHWEST AT THREE THOUSAND FIVE HUNDRED VFR. INBOUND FOR LANDING.*

Should there be no acknowledgement of a directed transmission to a ground station or a vehicle operator, reports shall be made in the broadcast format unless the ground station or vehicle operator subsequently establishes two-way contact, in which case pilots shall resume communicating by directed transmission.

Examples:

Directed: *FREDERICTON RADIO, THIS IS PIPER FOXTROT X-RAY YANKEE ZULU BEACON INBOUND LANDING RUNWAY EIGHTEEN.*

or,

FREDERICTON VEHICLES, THIS IS PIPER FOXTROT X-RAY YANKEE ZULU...

Broadcast: *FREDERICTON TRAFFIC, THIS IS PIPER FOXTROT X-RAY YANKEE ZULU...*

4.5.7 VFR Communication Procedures at Uncontrolled Aerodromes with MF and ATF Areas

(a) *Radio-equipped Aircraft:* The following reporting procedures shall be followed by the pilot-in-command of radio-equipped aircraft at uncontrolled aerodromes within an MF area and should also be followed by the pilot-in-command at aerodromes with an ATF:

- (i) *Listening Watch and Local Flying* [CAR 602.97 (2)] Maintain a listening watch on the mandatory frequency specified for use in the MF area. This should apply to ATF areas as well.
- (ii) *Before Entering Manoeuvring Area* [(CAR 602.99)] Report the pilot-in-command's intentions before entering the manoeuvring area.
- (iii) *Departure* (CAR 602.100)
 - (A) Before moving onto the take-off surface, report the pilot-in-command's departure intentions on the MF or ATF frequency. If a delay is encountered, broadcast intentions and expected length of delay, then rebroadcast departure intentions prior to moving onto the take-off surface;
 - (B) Before takeoff, ascertain by radio on the MF or ATF frequency and by visual observation that there is no likelihood of collision with another aircraft or a vehicle during takeoff; and,
 - (C) After takeoff, report departing from the aerodrome traffic circuit, and maintain a listening watch on the MF or ATF frequency until clear of the area.
- (iv) *Arrival* (CAR 602.101)
 - (A) Report before entering the MF area and, where circumstances permit, shall do so at least five minutes before entering the area, giving the aircraft's position, altitude and estimated time of landing and the pilot-in-command's arrival procedure intentions;
 - (B) Report when joining the aerodrome traffic circuit, giving the aircraft's position in the circuit;
 - (C) Report when on downwind leg, if applicable;
 - (D) Report when on final approach; and,
 - (E) Report when clear of the surface on which the aircraft has landed.
- (v) *Continuous Circuits* (CAR 602.102)
 - (A) Report when joining the downwind leg of the circuit;

- (B) Report when on final approach; stating the pilot-in-command's intentions; and,
 - (C) Report when clear of the surface on which the aircraft has landed.
- (vi) *Flying Through an MF Area* (CAR 602.103)
- (A) Report before entering the MF or ATF area and, where circumstances permit, shall do so at least five minutes before entering the area, giving the aircraft's position and altitude and the pilot-in-command's intentions; and,
 - (B) Report when clear of the MF or ATF area.

NOTE: In the interest of minimizing possible conflict with local traffic and minimizing radio congestion on the MF or ATF, pilots of en-route VFR aircraft should avoid passing through MF or ATF areas.

(b) *NORDO:* NORDO aircraft will only be included as traffic to other aircraft and ground traffic as follows:

- (i) *Arrival:* from five minutes before the ETA until ten minutes after the ETA, and
- (ii) *Departure:* from just prior to the aircraft departing until ten minutes after the departure, or until the aircraft is observed/reported clear of the MF area.

4.5.8 Aircraft Without Two-Way Radio (NORDO/ROONLY)

4.5.8.1 Prior Arrangements

Aircraft without a functioning two-way radio may operate on the manoeuvring area or within the MF area associated with an uncontrolled aerodrome, provided:

- (a) an FSS, a CARS, or an RCO through which RAAS is provided, is located at the aerodrome and is operating at the time proposed for the operation; and
- (b) prior arrangements have been made, by telephone or in person, with the appropriate agency, FSS, CARS, or in the case of a RAAS, the FSS.

NOTES: 1. Prior arrangements for an AAS location: phone the "emergency only" number listed in the CFS under COMM / RADIO for the FSS serving the AAS location.

- 2. Prior arrangements for a RAAS location: the FSS or FIC serving a RAAS location is shown in the CFS under COMM / RCO for the RAAS location.
 - (a) If an FSS serves the RAAS location: phone the "emergency only" number listed in the CFS under COMM / RADIO for the FSS serving the RAAS location; or
 - (b) If an FIC serves the RAAS location: phone the number listed in the CFS under FLT PLAN / FIC for the RAAS location.

When a pilot-in-command intends to operate at an uncontrolled aerodrome for which an MF has been designated, the pilot-in-command shall ascertain by visual observations that no other aircraft or vehicle is likely to come into conflict with the aircraft during takeoff or landing.

Pilots of NORDO/ONLY aircraft must be extremely vigilant when operating at either controlled or uncontrolled aerodromes and ensure through prior arrangements that other aircraft and vehicles will be informed of their presence within the area.

4.5.8.2 Traffic Circuits - NORDO/ONLY

When approaching an aerodrome, pilots of NORDO/ONLY aircraft shall enter the circuit as illustrated in Figure 4.6 and ensure that the aircraft completes at least two sides of a rectangular circuit before turning on to the final approach path.

4.5.8.3 ONLY

When operating an aircraft equipped with a VHF receiver capable of receiving transmissions on the MF, pilots shall maintain a listening watch on the MF when operating on the manoeuvring area or within the MF area.

4.6 HELICOPTER OPERATIONS AT CONTROLLED AIRPORTS

Two modes of helicopter airborne taxiing operations have been defined to accommodate the movement of helicopters at controlled airports; these are HOVER TAXI and AIR TAXI.

Hover Taxi is the movement of a helicopter above the surface of an aerodrome, in ground effect, and at airspeeds less than approximately 20 kt. The actual height may vary; some helicopters require hover taxi above 25 feet AGL to reduce ground effect turbulence or provide clearance for cargo slingloads.

Air Taxi is the movement of a helicopter above the surface of an aerodrome normally below 100 feet AGL. The pilot is solely responsible for selecting an appropriate height and airspeed for the operation being conducted and consistent with existing traffic and weather conditions. Pilots are cautioned of the possibility of the loss of visual references when conducting air taxi operations. Because of the greater operating flexibility, an air taxi clearance is to be expected unless traffic conditions will not permit this mode of operation.

When a helicopter is wheel-equipped and the pilot wishes to taxi on the ground, ATC should be informed when the clearance is requested.

NOTE: Helicopter pilots are reminded that aircraft, vehicle and personnel movements are not controlled on airport aprons, and that caution must be exercised at all times during any surface movement, hover or air taxiing.

5.0 VFR EN ROUTE PROCEDURES

5.1 MONITORING, BROADCASTING ON 126.7 MHZ AND POSITION REPORTING EN ROUTE

Pilots operating VFR en route in uncontrolled airspace when not communicating on an MF, or an ATF, or VFR on an airway should continuously monitor 126.7 MHz and whenever practicable, broadcast their identification, position, altitude and intentions on this frequency to alert other VFR or IFR aircraft that may be in the vicinity. Although it is not mandatory to monitor 126.7 MHz and broadcast reports during VFR or VFR-OTT flights, pilots are encouraged to do so for their own protection.

Pilots are encouraged to make position reports on the appropriate FISE frequency to an FIC where they are recorded by the flight service specialist and are immediately available in the event of SAR action. The following reporting format is recommended:

- | | |
|-------------------|------------------|
| 1. Identification | 4. Altitude |
| 2. Position | 5. VFR / VFR-OTT |
| 3. Time over | 6. Destination |

Example:

Pilot: *QUEBEC RADIO, THIS IS CESSNA GOLF INDIA GOLF BRAVO ON THE GATINEAU R-C-O, VFR (or VFR OVER-THE-TOP) POSITION REPORT.*

Radio: *CESSNA GOLF INDIA GOLF BRAVO, QUEBEC RADIO, GO AHEAD.*

Pilot: *QUEBEC RADIO, GOLF INDIA GOLF BRAVO, BY OTTAWA AT FIVE EIGHT, FOUR THOUSAND FIVE HUNDRED, VFR (or VFR OVER-THE-TOP), DESTINATION SUDBURY.*

- NOTES:
- As shown in the example, it is important on initial contact that the pilot alerts the FIC to the fact that it is a VFR or VFR-OTT position report and indicates the name of the location of the RCO followed by the letters R-C-O in a non-phonetic form.
 - The ETA destination or next reporting point may be included.
 - Under certain conditions position reports are required prior to entering the ADIZ when operating on a DVFR flight plan or a defence flight itinerary. (See RAC 2.13 and 3.9.)

5.2 ACKNOWLEDGEMENT OF CLEARANCES

Pilots of VFR flights shall read back the text of an ATC clearance when requested by an ATC unit.

5.3 ALTITUDES AND FLIGHT LEVELS – VFR

Aircraft shall be operated at altitudes or flight levels appropriate to the direction of flight when in level cruising flight above 3 000 feet AGL.

5.4 MINIMUM ALTITUDES — VFR (CARs 602.14 AND 602.15)

Minimum Altitudes and Distances

602.14

- (1) This subsection was repealed on 2003/03/01.
- (2) Except where conducting a takeoff, approach or landing or where permitted under Section 602.15, no person shall operate an aircraft
- over a built-up area or over an open-air assembly of persons unless the aircraft is operated at an altitude from which, in the event of an emergency necessitating an immediate landing, it would be possible to land the aircraft without creating a hazard to persons or property on the surface, and, in any case, at an altitude that is not lower than
 - for aeroplanes, 1,000 feet above the highest obstacle located within a horizontal distance of 2,000 feet from the aeroplane,
 - for balloons, 500 feet above the highest obstacle located within a horizontal distance of 500 feet from the balloon, or
 - for an aircraft other than an aeroplane or a balloon, 1,000 feet above the highest obstacle located within a horizontal distance of 500 feet from the aircraft; and
 - in circumstances other than those referred to in paragraph (a), at a distance less than 500 feet from any person, vessel, vehicle or structure.

Permissible Low Altitude Flight

602.15

- (1) A person may operate an aircraft at altitudes and distances less than those specified in subsection 602.14(2) where the aircraft is operated at altitudes and distances that are no less than necessary for the purposes of the operation in which the aircraft is engaged, the aircraft is operated without creating a hazard to persons or property on the surface and the aircraft is operated
- for the purpose of a police operation that is conducted in the service of a police authority;
 - for the purpose of saving human life;
 - for fire-fighting or air ambulance operations;
 - for the purpose of the administration of the Fisheries Act or the Coastal Fisheries Protection Act;
 - for the purpose of the administration of the national or provincial parks; or
 - for the purpose of flight inspection.
- (2) A person may operate an aircraft, to the extent necessary for the purpose of the operation in which the aircraft is engaged, at altitudes and distances less than those set out in
- paragraph 602.14(2)(a), where operation of the aircraft is authorized under Subpart 3 or Section 702.22; or
 - paragraph 602.14(2)(b), where the aircraft is

operated without creating a hazard to persons or property on the surface and the aircraft is operated for the purpose of

- aerial application or aerial inspection,
- aerial photography conducted by the holder of an air operator certificate,
- helicopter external load operations, or
- flight training conducted by or under the supervision of a qualified flight instructor.

NOTES: The hazards of low flying cannot be over-emphasized. In addition to the normal hazards of low flying, such as impact with the ground, two issues regarding man-made structures should be stressed.

- All obstructions extending 300 ft AGL or higher, or lower if deemed hazardous by TC, will be charted on VNCs and VTAs.

New obstructions, correctly reported by the owner to TC and NAV CANADA, will be NOTAMed and inserted in the CFS and eventually (next edition) charted on the applicable VNC and VTA. (Pilots noting obstructions not depicted are asked to alert TC).

- Wire-strikes account for a significant number of low flying accidents. A number of these accidents occur over level terrain, in good weather and at very low altitudes.

The regulations governing low level flight are located in several areas of the CARs. It is the responsibility of the pilots and the companies they work for to ensure that all regulations are strictly adhered to.

5.5 MINIMUM ALTITUDES — OVERFLYING AERODROMES [CARs 602.96(4) AND (5)]

602.96

- (4) Unless otherwise authorized by the appropriate air traffic control unit, no pilot-in-command shall operate an aircraft at a height of less than 2 000 feet over an aerodrome except for the purpose of landing or taking off or if the aircraft is operated pursuant to subsection (5).

602.96

- (5) Where it is necessary for the purposes of the operation in which the aircraft is engaged, a pilot-in-command may operate an aircraft at less than 2 000 feet over an aerodrome, where it is being operated
- in the service of a police authority;
 - for the purpose of saving human life;
 - for fire-fighting or air ambulance operations;
 - for the purpose of the administration of the *Fisheries Act or the Fisheries Protection Act*;
 - for the purpose of the administration of the national or provincial parks;
 - for the purpose of flight inspection;

- (g) for the purpose of aerial application or aerial inspection;
- (h) for the purpose of highway or city traffic patrol;
- (i) for the purpose of aerial photography conducted by the holder of an air operator certificate;
- (j) for the purpose of helicopter external load operations; or
- (k) for the purpose of flight training conducted by the holder of a flight training unit operator certificate.

5.6 CONTROLLED VFR (CVFR) PROCEDURES

Pilots intending to fly CVFR shall file a flight plan and obtain an ATC clearance prior to entering Class B airspace. The ATC clearance will not normally be issued prior to takeoff unless the airspace within a control zone is Class B. The ATC clearance will normally be issued upon receipt of a position report filed by the pilot upon reaching the last 1 000 feet altitude below the base of Class B or before entering laterally. This procedure is intended to ensure that the radio equipment is operating and to remind the pilots that, while outside of Class B airspace, ATC separation is not provided and that they must maintain a vigilant watch for other traffic. The ATC clearance will contain the phrase “MAINTAIN (altitude) VFR”.

CVFR flights must be conducted in accordance with procedures designed for use by IFR flights, except when IFR weather conditions are encountered, the pilot of a CVFR flight must avoid such weather conditions. This should be accomplished by:

- (a) requesting an amended ATC clearance which will enable the aircraft to remain in VFR weather conditions
- (b) requesting an IFR clearance if the pilot has a valid instrument rating and the aircraft is equipped for IFR flight.
- (c) request special VFR if within a control zone.

If unable to comply with the preceding, ensure that the aircraft is in VFR weather conditions at all times and leave Class B airspace horizontally or by descending. If the airspace is a control zone, land, at the aerodrome on which the control zone is based. In both cases, inform ATC as soon as possible of the action taken.

5.7 EN ROUTE RADAR SURVEILLANCE

When operating in areas where radar coverage exists, VFR flights with transponder equipped aircraft may request radar traffic information. ATC will provide this information, traffic (or workload) permitting (see RAC 1.5.3).

The service is provided by the ACC or TCU responsible for IFR control service in the area(s) concerned. The appropriate frequency for the controlling ATC unit may be found in the CFS (nearest controlled airport), enroute (IFR) charts or by request to a FIC.

Phraseology: “REQUEST RADAR SURVEILLANCE”

Example:

“EDMONTON ADVISORY, CESSNA SKYLANE FOXTROT ALPHA BRAVO CHARLIE, TEN NORTHEAST OF CAMROSE AT 6500 VFR SQUAWKING 1200 EN ROUTE TO VILLENEUVE; REQUEST RADAR SURVEILLANCE.”

5.8 VFR OPERATIONS WITHIN CLASS C AIRSPACE

The following are the basic procedures for entry into, and for operation within Class C airspace. Pilots should consult the applicable VTA chart for any additional procedures that may be required for that particular Class C airspace.

(a) Pilot Procedures

- (i) Obtain ATIS information (when available) prior to contacting ATC.
- (ii) Contact ATC on VFR advisory frequency (depicted on VTA charts) prior to entry into Class C airspace and provide the following information:
 - aircraft type and identification,
 - position (preferably over a call-up point depicted on the VTA chart or a bearing and distance from it, otherwise another prominent reporting point or a VOR radial or VOR/DME fix),
 - altitude,
 - destination and route, and
 - transponder code (if transponder equipped), and ATIS (code) received.
- (iii) Comply with ATC instructions received. Any ATC instruction issued to VFR flights is based on the firm understanding that a pilot will advise ATC immediately if compliance with the instructions would result in not being able to maintain adequate terrain or obstruction clearance, or to maintain flight in accordance with VFR. If so advised, ATC will issue alternate instructions.

(b) ATC Procedures

- (i) Identify the aircraft with radar. (Pilots may be required to report over additional fixes, or squawk ident on their transponder.) The provision of an effective radar service is dependent upon communications equipment capabilities and the adequacy of the radar-displayed information. In the latter case, it may be difficult to maintain radar identification of aircraft which are not operating on specific tracks or routes (i.e., sightseeing, local training flights, etc.), and pilots will be advised when radar service cannot be provided.
- (ii) Issue landing information on initial contact or shortly thereafter unless the pilot states that the appropriate ATIS information has been received.

- (iii) Provide the aircraft with routing instructions or radar vectors whenever necessary. The pilot will be informed when vectoring is discontinued except when transferred to a tower. Occasionally, an aircraft may be held at established fixes within Class C airspace to await a position in the landing sequence.
- (iv) Issue traffic information when two or more aircraft are held at the same fix, or whenever in the controller's judgement a radar-observed target might constitute a hazard to the aircraft concerned.
- (v) When required, conflict resolution will be provided between IFR and VFR aircraft, and upon request, between VFR aircraft.
- (vi) Visual separation may be effected when the pilot reports sighting a preceding aircraft and is instructed to follow it.
- (vii) Inform the pilot when radar service is terminated, except when the aircraft has been transferred to a tower.

6.0 INSTRUMENT FLIGHT RULES (IFR) — GENERAL

6.1 ATC CLEARANCE

An ATC clearance shall be obtained before takeoff from any point within controlled airspace or before entering controlled airspace for flight under IFR or during IMC.

A clearance received by a pilot must be read back to the controller (CAR 602.31), except in certain circumstances. When the clearance is received on the ground, before departing a controlled aerodrome, and a SID is included in the clearance, the pilot only needs to acknowledge receipt of the clearance by repeating the aircraft call sign and the transponder Code that was assigned. If there is an amendment to the altitude contained in the SID, that altitude shall also be read back. At any time that the controller requests a full readback, the pilot shall comply. Also, the pilot may, at any time, read back a clearance in full to seek clarification.

Whenever a clearance is received and accepted by the pilot, the pilot shall comply with the clearance. If a clearance is not acceptable, the pilot shall immediately notify ATC of this fact because acknowledgement of the clearance alone will be taken by the controller as acceptance.

Deviations from a clearance shall not be made except in an emergency that necessitates immediate action or in order to respond to an ACAS/TCAS resolution advisory or a warning from a ground proximity warning system (GPWS). In these cases, the pilot shall inform ATC as soon as possible and obtain an amended clearance (CAR 602.31).

6.2 IFR FLIGHTS IN VMC

A pilot may elect to conduct a flight in accordance with IFR in VMC. Flights operating in accordance with IFR shall continue in accordance with IFR, regardless of weather conditions. An IFR clearance provides separation between IFR aircraft in controlled airspace only. Pilots operating IFR must be aware of the need to provide their own visual separation from VFR aircraft when operating in VMC and from any other aircraft when operating in uncontrolled airspace.

A pilot may cancel IFR, or close the IFR flight plan, provided the aircraft is operating in VMC, is outside Class A or B airspace, and it is expected that the flight will not return to IMC. If the pilot closes the IFR flight plan or cancels IFR, ATC will discontinue the provision of IFR control service.

Refer to RAC 3.12.2 for information on the requirement to submit an arrival report and on the provision of alerting service upon closure or cancellation of IFR. Provided the destination remains the same, a pilot may change an IFR flight plan to a VFR flight plan without having to file a new flight plan. ATIS will, however, confirm the aircraft's destination and ETA and obtain a search and rescue time from the pilot.

6.2.1 IFR Clearance with VFR Restrictions

ATC may issue an IFR clearance for an aircraft to depart, climb or descend VFR until a specified time, altitude, or location provided

- (a) the pilot requests it;
- (b) the aircraft is outside Class A airspace;
- (c) the aircraft is within Class B airspace at or below 12 500 ft ASL or within Class C, D or E airspace; and
- (d) the weather conditions permit.

Pilots are reminded that during such a VFR restriction they must provide their own separation, including wake turbulence separation, from other IFR aircraft as well as from the VFR traffic. Controllers normally issue traffic information concerning other IFR aircraft, particularly in marginal weather conditions. If compliance with the restriction is not possible, the pilot should immediately advise ATC and request an amended clearance.

6.2.2 VFR Release of an IFR Aircraft

When a delay is experienced in receiving an IFR departure clearance, a pilot may request approval to depart and maintain VFR until an IFR clearance can be received. The conditions in RAC 6.2.1 also apply in this situation. If the request for a VFR departure is approved, the pilot will be given a time, altitude or location at which to contact ATC for an IFR clearance. Depending upon the reasons for the IFR departure clearance delay, a VFR departure of an IFR flight may not be approved by the IFR unit. In situations such as these, it may be desirable for the pilot to wait for the IFR departure clearance.

6.3 EMERGENCIES AND EQUIPMENT FAILURES – IFR

6.3.1 Declaration of Emergency

Whenever pilots are faced with an emergency situation, ATC expects the pilot to take whatever action is considered necessary. ATC will assist pilots in any way possible whenever an emergency is declared. Pilots are requested to advise ATC of any deviations from IFR altitudes or routes necessitated by an emergency situation as soon as it is practicable in order that every effort can be made to minimize conflicts with other aircraft.

Pilots of transponder-equipped aircraft, when experiencing an emergency and unable to establish communications immediately with an ATC unit, may indicate “Emergency” to ATC by adjusting the transponder to reply to Mode A/3 Code 7700. Thereafter, radio communications should be established with ATC as soon as possible.

It should be pointed out, however, that when Code 7700 is used, the signal may not be detected because the aircraft may not be within the range of SSR coverage.

6.3.2 Two-Way Communications Failure

It is impossible to provide regulations and procedures applicable to all possible situations associated with a two-way communications failure. During a communications failure, when confronted by a situation not covered in the regulations, pilots are expected to exercise good judgment in whatever action they elect to take. The following procedures are the standard communications failure procedures; however, they may be superseded by specific procedures that take precedence. For example, some SID procedures may have specific published communications failure procedures.

6.3.2.1 General

Unless otherwise authorized by ATC, the pilot-in-command of an aircraft that experiences a two-way communications failure when operating in or cleared to enter controlled airspace under IFR, or when operating in or cleared to enter Class B or C airspace under VFR shall:

- (a) select the transponder to reply to Mode A/3 Code 7600 interrogations, if the aircraft is transponder-equipped;
- (b) maintain a listening watch on appropriate frequencies for control messages or further clearances; acknowledge receipt of any such messages by any means available, including the use of approved satellite voice equipment or the selective use of the normal/standby functions of transponders;
- (c) attempt to contact any ATC facility or another aircraft, inform them of the difficulty, and request they relay the information to the ATC facility with whom communications are intended;
- (d) comply with the procedures specified by the Minister in the CAP and the CFS, except where specific instructions to cover an anticipated communications failure have been received from an ATC unit; and
- (e) attempt to contact the appropriate NAV CANADA ATS unit by means of a conventional cell or satellite phone, when all of the above attempts have failed (see COM 5.15).

NOTE: Approved SATCOM voice equipment refers to on board embedded equipment. Permanent satellite voice equipment is installed and tested in accordance with appropriate certification and airworthiness standards.

6.3.2.2 IFR Flight Plan

- (a) *Visual Meteorological Conditions (VMC)*: If the failure occurs in VMC, or if VMC are encountered after the failure, the pilot-in-command shall continue the flight under VFR and land as soon as practicable.

NOTE: This procedure applies in any class of airspace. The primary purpose is to preclude extended IFR operation in controlled airspace in VMC. However, it is not intended that the requirement to “land as soon as practicable” be construed to mean “land as soon as possible.” The pilot retains the prerogative of exercising his/her best judgment and is not required to land at an unauthorized airport, at an airport unsuitable for the type of aircraft flown, or to land only minutes short of destination.

(b) *Instrument Meteorological Conditions (IMC)*: If the failure occurs in IMC, or if the flight cannot be continued under VMC, the pilot-in-command shall continue the flight according to the following:

- (i) *Route*
 - (A) by the route assigned in the last ATC clearance received and acknowledged;
 - (B) if being radar-vectorred, by the direct route from the point of communications failure to the fix, route, or airway specified in the vector clearance;
 - (C) in the absence of an assigned route, by the route that ATC has advised may be expected in a further clearance; or
 - (D) in the absence of an assigned route or route that ATC has advised may be expected in a further clearance, by the route filed in the flight plan.
- (ii) *Altitude*: At the highest of the following altitudes or FLs for *the route segment being flown*:
 - (A) the altitude(s) or FLs assigned in the last ATC clearance received and acknowledged;
 - (B) the minimum IFR altitude (see RAC 8.6.1); or
 - (C) the altitude or FL ATC has advised may be expected in a further clearance. (The pilot shall commence climb to this altitude/FL at the time or point specified by ATC to expect further clearance/ altitude change.)

NOTES 1: The intent of this is that an aircraft that has experienced a communications failure will, during any segment of a flight, be flown at an altitude that provides the required obstacle clearance.

2: If the failure occurs while being vectored at a radar vectoring altitude that is lower than a published IFR altitude, the pilot shall immediately climb to and maintain the appropriate minimum IFR altitude until arrival at the fix, route or airway specified in the clearance.

- (iii) *Descent for Approach*: Maintain en route altitude to the navigation facility or the approach fix to be used for the IAP selected and commence an appropriate descent procedure at whichever of the following times is the most recent:
 - (A) the ETA [ETA as calculated from take-off time plus the estimated time en route filed or amended (with ATC)];
 - (B) the ETA last notified to and acknowledged by ATC; or
 - (C) the EAT last received and acknowledged.

If failure occurs after you have received and acknowledged a holding instruction, hold as directed and commence an instrument approach at the EAT or expected further clearance time (EFC), whichever has been issued.

NOTES 1: If the holding fix is not a fix from which an approach begins, leave the fix at the expected further clearance time if one has been received. If none has been received, proceed to a fix from which an approach begins upon arrival over

the clearance limit. Commence descent and/or approach as close as possible to the ETA as calculated from the filed estimated time en route or as amended with ATC.

- 2: If cleared for a STAR, maintain the appropriate altitude described in RAC 6.3.2.2(b) and proceed to the final approach fix (FAF):
 - (a) via the published routing;
 - (b) via the published routing to the segment where radar vectors are depicted to commence, then direct to the facility or fix serving the runway advised by ATIS or specified in the ATC clearance, for a straight-in approach, if able, or for the full procedure if one is published;
 - (c) for a CLOSED RNAV STAR, by flying the arrival as published, including any vertical and speed restraints depicted in the procedure, and intercepting the final approach course for a straight-in approach; or
 - (d) for an OPEN RNAV STAR, by flying the arrival as published, including any vertical and speed restraints depicted in the procedure. The pilot is expected to delete the heading leg at the DTW, to initiate an auto-turn at the DTW and FAF and to intercept the final approach course for a straight-in approach.

For flights to the United States, communications failure procedures are essentially the same, but it is the pilot's responsibility to consult the appropriate American publications. Some instrument procedures do not include a procedure turn but include the statement "RADAR OR RNAV REQUIRED" as part of the procedure. The initial approach segment of these instrument procedures is being provided by ATC radar vectors. Without ATC radar vectoring, the instrument procedure may not have a published initial approach segment.

Should an aircraft communications failure occur while the aircraft is being vectored on one of these approaches, separately or as part of a STAR, the pilot is expected to comply with the communications failure procedure by selecting the transponder to Mode A/3 Code 7600 immediately. Pilots should always be aware of the traffic situation. For example, ATC may have indicated that your aircraft was second for an approach to Runway 06L; under these circumstances, the flight should be continued along the route that normally would have been expected under radar vectoring. In some cases of communications failure, pilots may need to revert to dead reckoning navigation (DR) to the final approach course. It is important to other aircraft and ATC for the aircraft experiencing a communications failure to continue the flight along a route that would permit the aircraft to conduct a straight-in approach and landing without unexpected manoeuvring. Pilots are expected to exercise good judgment in these cases. Unexpected manoeuvres, such as turns away from the final approach course, may cause traffic disruptions and conflicts.

If the communications failure occurs while being vectored at a radar vectoring altitude that is lower than a published IFR altitude (e.g., minimum sector altitude 25 NM), the pilot shall immediately climb to and maintain the appropriate minimum IFR altitude until arrival at a fix associated with the instrument procedure.

Modern technology has introduced new on-board communications capabilities, such as airborne telephone communications. Pilots who are confronted with an aircraft communications failure may, if circumstances permit, use this new on-board technology to establish communications with the appropriate ATC units. NAV CANADA publishes the phone numbers of ACCs, control towers, FICs and FSSs in the CFS.

6.3.3 Reporting Malfunctions of Navigation and Communications Equipment

The pilot-in-command of an aircraft in IFR flight within controlled airspace should report immediately to the appropriate ATC unit any malfunction of navigation or air-to-ground communications equipment.

Examples:

1. Loss of VOR, ADF or low frequency navigation capability.
2. Complete or partial loss of ILS capability.
3. Impairment of air-to-ground communications capability.
4. Impairment of transponder serviceability.

Having received this information, ATC will take into account any limitations in navigation or air-to-ground communications equipment in further clearances to the aircraft.

6.3.4 Fuel Dumping

Whenever it is necessary to jettison fuel, the pilot should immediately notify ATC and provide information such as the course to be flown, the period of time and weather conditions. To allow for adequate vaporization, fuel dumping should be carried out at least 2 000 feet above the highest obstacle within 5 NM of the track to be flown. ATC may suggest an alternate area where fuel should be dumped; aircraft will be encouraged to dump fuel on a constant heading over unpopulated areas and clear of heavy traffic. When necessary information has been obtained, ATC will broadcast on appropriate frequencies a “fuel dumping” advisory. Pilots should advise ATC immediately when fuel dumping has been completed.

6.4 IFR SEPARATION

6.4.1 General

The following information is intended to acquaint pilots with some of the basic non-radar separation standards applied by ATC and so facilitate flight planning and understanding of ATC techniques.

6.4.2 Vertical Separation – General

The standard vertical separation minima is as follows:

- FL290 and below – 1 000 feet;
- above FL290 – 2 000 feet.

6.4.3 Vertical Separation Between Flight Levels and Altitudes ASL

When the altimeter setting is less than 29.92” Hg, there will be less than 1 000 feet vertical separation between an aircraft flying at 17 000 feet ASL with that altimeter setting and an aircraft flying at FL180, (with altimeter set at 29.92” Hg); therefore, the lowest usable flight level will be assigned or approved in accordance with the following table:

Altimeter Setting	Lowest Usable Flight Level
29.92” or higher	FL180
29.91” to 28.92”	FL190
28.91” to 27.92”	FL200

6.4.4 Longitudinal Separation—Distance-Based

Longitudinal separation of IFR flights based on distance is established by ATC on the basis of position reports, expressed in units of distance, from the concerned aircraft determined in relation to a common point. To account for the effect of slant range, controllers must know when distance reports are derived from DME when establishing longitudinal separation between a mix of RNAV/GPS- and DME-equipped aircraft.

To this end, pilots should report distances based on RNAV and GPS in miles, e.g. 30 mi. from “Someplace.” When distance reports are based on DME, pilots should state DME, e.g. 30 DME from “Someplace.”

NOTE: RNAV position reports derived from DME-DME computations are not affected by slant range.

6.4.5 Lateral Separation – General

Lateral separation of IFR flights is provided by ATC in the form of “airspace to be protected” in relation to a holding procedure, instrument approach procedure or the approved track. The dimensions of protected airspace for a particular track take into account the accuracy of navigation that can be reasonably expected. For track segments within signal coverage of NDB, VOR or TACAN stations and along bearings/courses/radials of such facilities, protected airspace takes into account the accuracy of available track guidance, accuracy of airborne receiver and indicator equipment, and a small pilotage tolerance. Separation is considered to exist provided the airspaces protected for each aircraft do not overlap. It is essential, therefore, that accuracy capability of navigation equipment be maintained.

Pilots of IFR or controlled VFR flights must adhere as closely as practicable to the centreline of their approved airway or track. If the aircraft inadvertently deviates from the approved track, immediate action must be taken to regain the centreline

as soon as practicable. Pilots realizing that they are outside the airspace protected for their approved track must notify the appropriate ATC unit immediately.

6.4.6 Lateral Separation – Airways and Tracks

In the low level airspace, the airspace to be protected is the full width of the airway as illustrated in RAC 2.7.1.

In the high level airspace, all airspace is controlled within the Southern, Northern, and Arctic Control Areas. As a result, a high level airway is “a prescribed track between specified radio aids to navigation” and, thus, has no defined lateral dimensions. Therefore, the airspace to be protected for airways and/or tracks in the high level airspace is the same as that for low level airways.

Along off-airway tracks the “airspace to be protected” is 45 NM each side of that portion of the track which is beyond navigational and signal coverage range.

Figure 6.1 – Airspace to be Protected Along Off-Airway Tracks

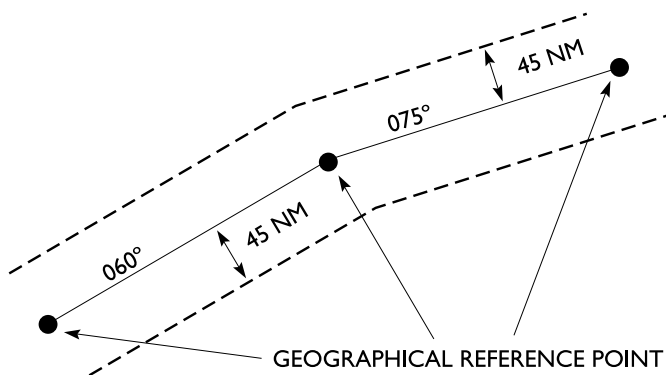

Additional airspace will be protected at and above FL180 on the manoeuvring side of tracks that change direction by more than 15° overhead navigation aids or intersections. It is expected that pilots of aircraft operating below FL180 will make turns so as to remain within the normal width of airways or airspace protected for off-airway tracks.

Figure 6.2 – Additional Airspace to be Protected for Turns

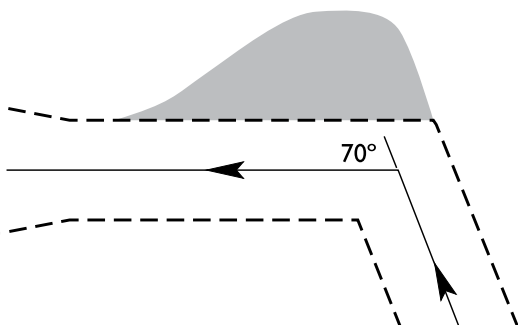

Normally, the airspace to be protected for an approved track will be based on the premise that the changeover from one navigation reference to another will take place approximately midway between facilities. Where this is not possible due to a difference in the signal coverage provided by two adjacent navigation aids, the equal signal point on an airway segment will be shown.

To remain clear of restricted areas, active danger or alert areas, or active areas such as the Churchill Rocket Range, pilots should file a flight plan so that the airspace-to-be-protected for the intended track do not overlap the area of concern.

6.4.7 Lateral Separation – Instrument Approach Procedure

Air traffic controllers have been authorized to consider the basic horizontal dimensions of intermediate approach areas, final approach areas and missed approach areas, for obstacle clearance purposes, as the airspace-to-be-protected for aircraft conducting standard instrument approach procedures. Adequate horizontal separation is then deemed to exist when the airspace-to-be-protected for such aircraft do not overlap the airspace-to-be-protected for aircraft enroute, holding or conducting simultaneous adjacent instrument approaches.

As with other separation standards based on the airspace-to-be-protected concept, it will be the pilot’s responsibility to remain within the limits of airspace-to-be-protected. This can be accomplished by following the procedures published in CAP or approved for company use. If a pilot who is operating in controlled airspace anticipates being unable to conduct the approach as published, the pilot should inform ATC so that separation from other aircraft concerned can be increased as necessary.

6.5 DEVELOPMENT OF INSTRUMENT PROCEDURES

Instrument procedure development worldwide follows one of two existing standards: *ICAO Procedures for Air Navigation Services—Aircraft Operations*, Volume II—*Construction of Visual and Instrument Flight Procedures* (Doc 8168); or the *United States Standard for Terminal Instrument Procedures* (TERPS). Instrument procedures in CDA are developed in accordance with a document entitled *Criteria for the Development of Instrument Procedures* (TP 308). This document is a joint TC/DND publication and prescribes standardized methods for use in designing both civil and military instrument flight procedures.

In order to achieve ICAO regional commonality, the instrument procedure design standards and criteria contained in TP 308 are modeled after the standards and criteria contained in the TERPS.

Strict adherence by pilots to the published instrument procedures will ensure an acceptable level of safety in flight operations.

RAC

7.0 INSTRUMENT FLIGHT RULES – DEPARTURE PROCEDURES

7.1 AERODROME OPERATIONS

Pilots should read RAC 4.2 to 4.5 in conjunction with the IFR departure procedures listed in this section.

7.2 ATIS BROADCASTS

If available, the basic aerodrome information should be obtained from ATIS prior to requesting taxi clearance.

7.3 INITIAL CONTACT

On initial contact with ATC (clearance delivery or ground control), a pilot departing IFR should state the destination and planned initial cruising altitude.

7.4 IFR CLEARANCES

At locations where a “Clearance Delivery” frequency is listed, pilots should obtain their IFR clearance on this frequency prior to contacting ground control. Where no clearance delivery frequency is listed, the IFR clearance will normally be relayed by ground control after taxi authorization has been issued. However, due to high fuel consumption during ground running time, some pilots of turbojet aircraft may wish to obtain their IFR clearance prior to starting engines. Pilots using this procedure should call ATC, using a phrase such as **READY TO START NOW** or **READY TO START AT (TIME)**. Normally this request should be made within 5 minutes of the planned engine start time.

New technology available in some control towers permits the electronic delivery of initial IFR clearances via air-ground data link (AGDL). This new delivery method is known as pre-departure clearance (PDC) and is available to those airline companies with an on-site computer capable of interfacing with ATC and the data link service provider.

7.5 SID

At certain airports, an IFR departure clearance may include departure instructions known as a standard instrument departure (SID). A SID is a planned IFR ATC departure procedure, published in the CAP, for the pilot’s and controller’s use in graphic and textual form. SIDs provide a transition from the terminal to the appropriate en route structure, and may be either:

- (a) *pilot navigation SIDs*—established where the pilot is required to use the chart as reference for navigation to the en route phase; or

- (b) *vector SIDs*—established where ATC will provide radar navigational guidance to a filed/assigned route or to a fix depicted on the chart. Pilots are expected to use the SID chart as reference for navigation until radar vectoring has commenced.

Pilots of aircraft operating at airports for which SIDs have been published will normally be issued a SID clearance by ATC. No pilot is required to accept a SID clearance. If any doubt exists as to the meaning of such a clearance, the pilot should request a detailed clearance.

Routings contained in SIDs will normally be composed of two segments:

- (a) an initial segment from the departure end of the runway to the position where the aircraft will first turn from the initial departure heading; and
- (b) a second segment, either via radar vectors or by pilot navigation, from the first turning point to the SID termination point.

When instructed to fly on the runway heading, or when flying a SID for which no specific heading is published, pilots are expected to fly or maintain the heading that corresponds with the extended centreline of the departure runway until otherwise instructed by ATC. Drift correction must not be applied, e.g. Runway 04, if the actual magnetic heading of the runway centreline is 044°, then fly a heading of 044°M.

When flying a SID for which a specific heading is published, the pilot is expected to steer the published SID heading until radar vectoring commences. This is because initial separation is based on divergence between assigned headings until radar separation is established.

When assigning SIDs, ATC will include the following:

- (a) the name of SID;
- (b) the SID termination fix, if appropriate;
- (c) the transition, if necessary; and
- (d) the time or location for the aircraft to expect a climb to an operationally suitable altitude or flight level, if necessary. (**NOTE:** An “expect further clearance” statement may be included in the SID chart.)

Example:

CLEARED TO THE CALGARY AIRPORT, TORONTO ONE DEPARTURE, FLIGHT PLANNED ROUTE.

NOTE: A SID termination fix may be a NAVAID, intersection, or DME and is normally located on an established airway where the SID terminates and the en route phase of flight commences. The SID, as published,

contains an altitude to climb to after departure; however, ATC may assign an altitude different from the altitude specified in the SID, provided the altitude is stated and a readback is obtained from the pilot prior to departure. In addition, where vector SIDs are used, ATC may assign a different initial departure heading. However, an ATC revision to any item of a SID does not cancel the SID.

Example:

CLEARED TO THE CALGARY AIRPORT, TORONTO ONE DEPARTURE, FLIGHT PLANNED ROUTE, CLIMB TO AMENDED ALTITUDE, SEVEN THOUSAND..

If an aircraft is issued a vector SID, radar vectors will be used, as traffic permits, to provide navigational guidance to the filed/assigned route and over the SID termination fix. However, if the controller or the aircraft will gain an operational advantage, the aircraft may be vectored on a route that will not take the aircraft over the SID termination fix.

In this case, if ATC had previously specified a SID termination fix as the location for the aircraft to expect to climb to an operationally suitable altitude or flight level, the controller shall cancel the SID. If, with the change of clearance, it is not practicable for the controller to assign an operationally suitable altitude or flight level, the controller will specify another location or time to expect the higher altitude.

Example:

SID CANCELLED, VECTORS TO (fix or airway) (heading). EXPECT FLIGHT LEVEL THREE FIVE ZERO AT FOUR FIVE D-M-E WEST OF EDMONTON VORTAC.

It is impossible to precisely define “operationally suitable altitudes” to meet requirements in all circumstances.

The following are considered operationally suitable altitudes or flight levels:

- (a) *piston aircraft*—flight planned altitude or lower; and
- (b) *other aircraft*—flight planned altitude or altitude as near as possible to the flight planned altitude, taking into consideration the aircraft’s route of flight. As a guideline, an altitude not more than 4 000 ft below the flight planned flight level in the high level structure will be considered as operationally suitable in most cases.

If it is not practicable for the controller to assign the flight planned altitude and if the pilot has not been informed as to when they may expect a clearance to another altitude, it is the pilot’s responsibility to advise ATC if the currently assigned altitude is not satisfactory to permit the aircraft to proceed to the destination airport, should a communications failure occur.

The controller will then be required to issue an appropriate “expect further clearance” statement or issue alternative instructions.

Controllers are required to issue a clearance to the altitude or flight level the pilot was told to expect prior to the time or location specified in an “expect further clearance” statement. [See RAC 6.3.2.2(b)(ii)(C)]. The pilot must ensure that further clearance is received because the “altitude to be expected” included in the clearance is not applicable:

- (a) once the aircraft has proceeded beyond the fix specified in the “expect further clearance” statement; or
- (b) once the time designated in the “expect further clearance” statement has expired.

SIDs may include specific communications failure procedures. These specific procedures supersede the standard communication failure procedures.

It is the pilot’s responsibility to follow the noise abatement procedures. SIDs, as published, will not contravene them. When ATC issues radar vectors, they will commence only after the requirements of the noise abatement procedure have been complied with.

The initial call to departure control should contain at least:

- (a) the aircraft call sign;
- (b) the departure runway;
- (c) the present vacating altitude (to the nearest 100-ft increment); and
- (d) the assigned (SID) altitude.

Example:

OTTAWA DEPARTURE, BEECH GOLF ALFA BRAVO TANGO, OFF RUNWAY 25, HEADING 250, LEAVING 1 900 FOR 4 000.

NOTE: An altitude readout is valid if the readout value does not differ from the aircraft reported altitude by more than 200 ft. Pilot altitude reports should be made to the nearest 100-ft increment.

7.6 NOISE ABATEMENT PROCEDURES – DEPARTURE

7.6.1 General

These aeroplane operating procedures for the takeoff and climb have been developed so as to ensure that the necessary safety of flight operations is maintained whilst minimizing exposure to noise on the ground. One of the two procedures listed in RAC 7.6.3 should be applied routinely for all takeoffs where noise abatement procedures are in effect.

Nothing in these procedures shall prevent the pilot-in-command from exercising his/ her authority for the safe operation of the aeroplane, except that when a climb gradient is published, it must be maintained, or alternate procedures must be adopted.

The procedures herein describe the methods for noise abatement when a noise problem is evident. They can comprise any one or more of the following:

- (a) use of noise preferential runways to direct the initial and final flight paths of aeroplanes away from noise-sensitive areas;
- (b) use of noise preferential routes to assist aeroplanes in avoiding noise-sensitive areas on departure and arrival, including the use of turns to direct aeroplanes away from noise-sensitive areas located under or adjacent to the usual takeoff and approach flight paths; and
- (c) use of noise abatement takeoff or approach procedures, designed to minimize the overall exposure to noise on the ground and, at the same time, maintain the required levels of flight safety.

7.6.2 Noise Preferential Runways

Preferred runway directions for takeoff are designated for noise abatement purposes; the objective being to use, whenever possible, those runways that permit aeroplanes to avoid noise-sensitive areas during the initial departure and final approach phases of flight.

Noise abatement is not the determining factor in runway designation under the following circumstances:

- (a) if the runway is not clear and dry, i.e., it is adversely affected by snow, slush, ice, water, mud, rubber, oil or other substances;
- (b) when the crosswind component, including gusts, exceeds 25 kt; and

- (c) when the tail wind component, including gusts, exceeds 5 kt.

NOTE: Although ATS personnel may select a preferential runway in accordance with the foregoing criteria, pilots are not obligated to accept the runway for taking off or landing. It remains the pilot's responsibility to decide if the assigned runway is operationally acceptable.

7.6.3 Noise Abatement Departure Procedures (NADP)

NADP are designed to minimize the environmental impact of departing aircraft without compromising safety. Typically, operators require two procedures: one to minimize close-in noise (NADP1), the other to minimize noise over a more distant noise-sensitive area (NADP2).

Under the NADP concept, airport operators identify their noise and emission control needs and may identify specific noise-sensitive areas. Aircraft operators choose the departure method that safely meets the airport operator's objectives.

When deciding on a noise abatement strategy, it is important to keep in mind that each procedure minimizes noise in its target area at the expense of relatively increased noise elsewhere. NADP1 reduces noise immediately after takeoff, but results in higher downrange noise than NADP2, and vice versa. For each aircraft type, powerplant and set of takeoff conditions, there is a distance at which the NADP1 and NADP2 noise contours cross over. The area from the takeoff to the crossover point defines the 'close-in' zone of NADP1, while the area beyond the crossover point is the effective range of NADP2.

When developing a noise abatement strategy, airports and air operators should consider the following:

- a noise abatement departure shall not invalidate an engine failure strategy;
- aircraft limitations, including maximum body angle limits, shall be respected at all times;
- where possible, each aircraft type should base its standard departure procedure on the noise abatement strategy that minimizes its overall noise impact;
- operators serving certain noise-sensitive airports may need to follow specific, non-standard departure procedures. Crew training and departure information shall address identification and procedural differences associated with alternate noise abatement procedures; and
- where applicable, air traffic control agencies should be involved in the development of noise abatement procedures, especially regarding take-off flight path in the event of an engine failure.

In addition to the above general requirements, the following operational limitations apply:

- NAPDs requiring reduced take-off thrust settings may only be flown when reduced thrust is permitted by the aircraft flight manual or aircraft operating manual;
- noise abatement procedures shall not be executed below 800 ft AAE;
- noise abatement procedures are not to be used when wind shear warnings exist, or the presence of wind shear or downburst activity is suspected; and
- conduct of noise abatement procedures is secondary to the satisfaction of obstacle requirements.

NAPDs start at or above 800 ft and initiate the final stage at or below 3 000 ft AAE, allowing operators to develop specific procedures to suit their local situations.

Operators transitioning from VNAP to NADP will note that the NADP1 envelope includes the former VNAP A procedure, while NADP2 includes the former VNAP B procedure.

To illustrate the NADP concept, two examples of compliant procedures appear below. Operators are free to design other procedures that fit within the NADP envelopes.

NADP 1 (criteria for a close-in noise abatement procedure):

This procedure involves a power reduction at or above the prescribed minimum altitude (no less than 800 ft) AAE and delaying flap/slat retraction until the prescribed maximum altitude (3 000 ft) AAE is attained. At the prescribed maximum altitude, accelerate and retract flaps/slats on schedule, while maintaining a positive rate of climb, and complete the transition to normal en-route climb speed. The initial climbing speed to the noise abatement initiation point is no less than $V_2 + 10$ kt.

Specific example of NADP 1:

- Initial climb to 800 ft AAE with take-off thrust and $V_2 + 10$ to 20 kt.
- Upon reaching an altitude of 800 ft AAE, adjust and maintain engine thrust in accordance with the noise abatement thrust schedule provided in the aircraft operating manual. Maintain a climb speed of $V_2 + 10$ to 20 kt with flaps and slats in the take-off configuration.
- At 3 000 ft AAE, while maintaining a positive rate of climb, accelerate and retract flaps/slats on schedule.

- At 3 000 ft AAE, accelerate to normal en-route climb speed.

NOTE: To assist in planning departure spacing, pilots intending to use NADP 1 at Canadian airports are to notify ATC Clearance Delivery or Ground Control. At airports where NADP 1 is the only procedure to follow, ATC does not need to be notified.

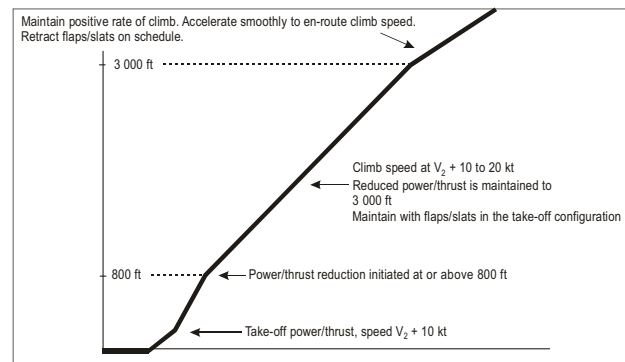

Noise abatement take-off climb — Example of a procedure alleviating noise close to the aerodrome (NADP 1)

NADP 2 (criteria for distant noise abatement procedure):

This procedure involves the initiation of flap/slat retraction at or above the prescribed minimum altitude (800 ft) AAE but before reaching the prescribed maximum altitude (3 000 ft) AAE. The flaps/slats are to be retracted on schedule, while maintaining a positive rate of climb. The thrust reduction is to be performed with the initiation of the first flaps/slats retraction or when the zero flaps/slats configuration is attained. At the prescribed maximum altitude, complete the transition to normal en-route climb procedures. The initial climbing speed to the noise abatement initiation point is no less than $V_2 + 10$ kt and the noise abatement procedure is not to be initiated at less than 800 ft AAE.

Specific example of NADP 2:

- Initial climb to 800 ft AAE with take-off thrust and $V_2 + 10$ to 20 kt.
- Upon reaching an altitude equivalent to 800 ft AAE, decrease aircraft body angle while maintaining a positive rate of climb, accelerate towards V_{ZF} speed and reduce thrust after flaps/slats retraction.
- Maintain a positive rate of climb and accelerate to and maintain a climb speed of $V_{ZF} + 10$ to 20 kt until 3 000 ft AAE.
- At 3000 ft AAE, accelerate to normal en-route climb speed.

The use of this guidance material should be limited to acquiring general insight into NADPs. In applying this guidance, users should seek expert noise and emissions advice.

RAC

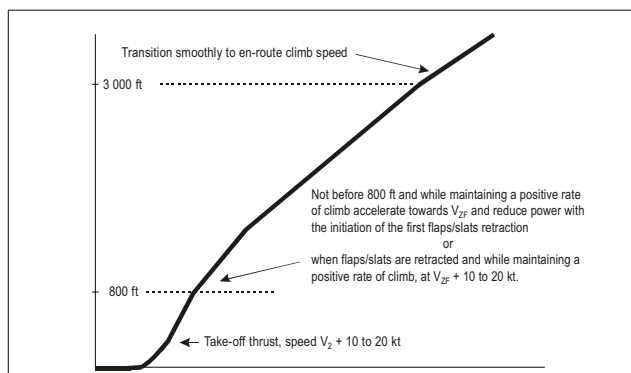

Noise abatement take-off climb — Example of a procedure alleviating noise distant from the aerodrome (NADP 2)

7.7 OBSTACLE AND TERRAIN CLEARANCE

Aerodromes that have an instrument approach procedure published in CAP also have a procedure referred to as an IFR departure procedure. IFR departure procedures are expressed in the form of “Takeoff Minima” on the aerodrome chart, and meet obstacle and terrain clearance requirements. These procedures are based on the premise that on departure an aircraft will:

- (a) cross at least 35 feet above the departure end of the runway;
- (b) climb straight ahead to 400 feet AAE before commencing any turns; and
- (c) maintain a climb gradient of at least 200 feet per NM throughout the climb to a minimum IFR altitude for en route operations. Climb gradients greater than 200 feet per NM may be published. In this case, the aircraft is expected to achieve and maintain the published gradient to the specified altitude or fix, then continue climbing at a minimum of 200 feet per NM until reaching a minimum IFR altitude for en route operations.

For flight planning purposes, departure procedures assume normal aircraft performance in all cases

IFR departure procedures in the “Takeoff Minima” box are shown as either:

- (a) 1/2 – This indicates that IFR departures from the specified runway(s) will be assured of obstacle and terrain clearance in any direction if the aircraft meets the previously stated premise. Pilots may consider this procedure as “Takeoff, climb on course”. The minimum visibility (unless otherwise approved by the appropriate approving authority) for takeoff in these circumstances is 1/2 SM. IFR takeoffs for rotorcraft are permitted when the takeoff visibility is one-half the CAP value, but no less than 1/4 SM.

- (b) * – The asterisk (*) following all or specific runways refers the pilot to the applicable minimum takeoff visibility (1/2 or SPECVIS) and corresponding procedures which, if followed, will ensure obstacle and terrain clearance. Procedures may include specific climb gradients, routings, visual climb requirements, or a combination thereof. Where a visual climb or manoeuvre is stated in the departure procedure, pilots are expected to comply with the Specified Takeoff Minimum Visibility (SPEC VIS) corresponding to the appropriate speed associated with the aircraft category listed in the following table:

AIRCRAFT CATEGORY	A	B	C	D
Specified Takeoff Minimum Visibility (SPEC VIS) in SM	1	1 1/2	2	2

- (c) NOT ASSESSED – IFR departures have not been assessed for obstacles. Pilots-in-command are responsible for determining minimum climb gradients and/or routings for obstacle and terrain avoidance.

In absence of a published visibility for a particular runway, a pilot may depart IFR by using a takeoff visibility that will allow avoidance of obstacles and terrain on departure. In no case should the takeoff visibility be less than 1/2 SM (1/4 SM for rotorcraft).

Where aircraft limitations or other factors preclude the pilot from following the published procedure, it is the pilot-in-command’s responsibility to determine alternative procedures which will take into account obstacle and terrain avoidance.

ATC terms such as “on departure, right turn climb on course” or “on departure, left turn on course” are not to be considered specific departure instructions. It remains the pilot’s responsibility to ensure that terrain and obstacle clearance has been achieved by conforming with the IFR departure procedures.

SIDs incorporate obstacle and terrain clearance within the procedure. Pilots should note that SIDs published only in textual form at military aerodromes do not incorporate obstacle and terrain clearance. At these aerodromes, it is the pilot’s responsibility to ensure appropriate obstacle and terrain clearance on departure.

7.7.1 Visual Climb Over the Airport (aerodrome)

The visual climb over the airport (VCOA)—sometimes referred to as “climb visual” or “visual climb” in the *Canada Air Pilot* (CAP)—was developed to provide an alternate IFR departure procedure for aircraft that cannot meet the greater-than-standard climb gradient specified in the primary instrument departure procedure.

NOTE: Occasionally, the VCOA may be the only available departure procedure developed for an aerodrome.

The VCOA differs from other instrument departure procedures in that the pilot must maintain certain visual references with the ground (and obstacles) until reaching a given altitude over the aerodrome.

NOTE: Even though the aircraft is being operated with visual references to the ground, it is still departing on an IFR clearance.

The VCOA text includes a specified take-off minimum visibility (SPEC VIS) and a climb-to altitude (ASL). The SPEC VIS is the minimum visibility (in SM) that a pilot requires to manoeuvre the aircraft while also maintaining a visual reference with the centre of the aerodrome. The climb-to altitude is the minimum altitude the aircraft must reach before departing from over the aerodrome.

It is the pilot's responsibility to see and avoid obstacles while climbing visually. The visual climb segment ends when the aircraft crosses the aerodrome at or above the required minimum altitude. Unless otherwise stated, from this point on, or when the expression "before proceeding on course" (BPOC) is used, obstacles will be cleared if the aircraft maintains a minimum climb gradient of 200 ft/NM to the en-route structure.

The pilot-in-command (PIC) should ensure that the reported ceiling is above the climb-to altitude and that the local prevailing visibility is equal to or greater than that required in the procedure. Additionally, before taxiing for departure, the PIC should inform ATC of the intention to perform a VCOA so that the appropriate coordination can be ensured. If ATC services are not available, then intentions should be broadcast on the ATF frequency (see RAC 7.9).

7.8 RELEASE FROM TOWER FREQUENCY

If the departure airport is located within a terminal control area, the departing IFR flight will be cleared by the tower to contact a specific control unit on a specified frequency once clear of conflicting airport traffic. At certain locations, flights will be advised prior to takeoff to change to a specified departure frequency. In this case, the change should be made as soon as practicable after takeoff.

If the departure airport is not located within a terminal control area, the pilot, when requesting release from tower frequency, should advise the tower of the agency or frequency to which he/she will change unless directions for the change were included in the ATC clearance.

7.9 IFR DEPARTURES FROM UNCONTROLLED AIRPORTS

Where a pilot-in-command intends to take off from an uncontrolled aerodrome, the pilot shall:

- obtain an ATC clearance if in controlled airspace;
- report their departure procedure and intentions on the appropriate frequency before moving on to the runway or before aligning the aircraft on the take off path; and

(c) ascertain by radio on the appropriate frequency and by visual observation that no other aircraft or vehicle is likely to come into conflict with the aircraft during takeoff.

The pilot-in-command shall maintain a listening watch:

- during takeoff from an uncontrolled aerodrome; and
- after takeoff from an uncontrolled aerodrome for which a MF has been designated, until the aircraft is beyond the distance or above the altitude associated with that frequency.

As soon as possible after reaching the distance or altitude associated with the MF, the pilot-in-command shall communicate with the appropriate ATC unit or a ground station on the appropriate en-route frequency.

Where IFR departures are required to contact an IFR control unit or ground station after takeoff, it is recommended that, if the aircraft is equipped with two radios, the pilot should also monitor the MF during the departure.

If the aerodrome is located in uncontrolled airspace, these procedures shall be followed except that an ATC clearance is not required. In addition to maintaining a listening watch, it is recommended that the pilot-in-command communicate with the appropriate ATC unit, FIC, or other ground station on the appropriate en-route frequency.

NOTE: It is recommended that pilots inform ATC if a flight will not commence within 60 min of the proposed departure time stipulated in an IFR flight plan. Failure to do so will result in activating the SAR process.

At an uncontrolled aerodrome, the initial IFR clearance may contain a time or an event-based departure restriction or clearance cancellation.

Examples:

ATC CLEARS AIRLINE123 (IFR clearance) DO NOT DEPART UNTIL 1340; CLEARANCE CANCELLED IF NOT AIRBORNE BEFORE 1349.

or

ATC CLEARS AIRLINE123 (IFR clearance) DO NOT DEPART UNTIL CESSNA ABC HAS LANDED; CLEARANCE CANCELLED IF NOT AIRBORNE BEFORE 1349.

In the first example, the clearance is valid the moment the time turns 1340, and in both examples, the clearance is cancelled the moment the time turns 1349.

7.10 ALERTING SERVICE IFR DEPARTURES FROM UNCONTROLLED AIRPORTS

At locations where communication with ATS is difficult, pilots may elect to depart VFR and obtain their IFR clearance once airborne. In Canada, if IFR clearance is not received prior to departure, SAR alerting service is activated based on the ETD filed in the flight plan. However, if departing from a Canadian airport that underlies airspace delegated to FAA control,

then responsibility for SAR alerting service is transferred to the FAA and FAA procedures apply. In such cases, alerting service is not activated until the aircraft contacts ATS for IFR clearance. Therefore, if the aircraft departs before obtaining its IFR clearance, alerting service is not provided until contact is established with ATS.

8.0 INSTRUMENT FLIGHT RULES (IFR) – EN ROUTE PROCEDURES

8.1 POSITION REPORTS

Pilots of IFR and controlled VFR flights are required to make position reports over compulsory reporting points specified on IFR charts, and over any other reporting points specified by ATC.

As specified in CAR 602.125—*Enroute IFR Position Reports*, the position report shall include the information in the sequence set out in the CFS, that is:

- (a) the identification;
- (b) the position;
- (c) the time over the reporting point in UTC;
- (d) the altitude or flight level;
- (e) the type of flight plan or flight itinerary filed;
- (f) the name of the next designated reporting point and ETA over that point in UTC;
- (g) the name only of the next reporting point along the route of flight (see Note); and
- (h) any additional information requested by ATC or deemed necessary by the pilot.

NOTE: Reporting points are indicated by a symbol on the appropriate charts. The “designated compulsory” reporting point is a solid triangle and the “on request” reporting point symbol is an open triangle. Position reports over an “on request” reporting point are only necessary when requested by ATC. Therefore, no mention of an “on request” reporting point needs to be made in any position report unless it has been requested by ATC.

Enroute IFR and controlled VFR flights should establish DCPC wherever possible. PALs have been established at a number of locations to extend the communications coverage. Some PAL locations also employ a radio re-transmit unit (RRTU). The purpose of the RRTU is to transmit a pilot’s broadcast from one PAL location over another frequency at a different PAL location. This allows the pilot to know when the controller is working communications traffic on a

different PAL frequency. Controllers at an ACC can disable this equipment when communications workload warrants. However, it must be remembered that, while the DCPC provides direct contact with the IFR unit at locations where there is no VFR control and an AAS or RAAS is provided, pilots must also communicate with the FSS or FIC for local traffic information. Whenever DCPC cannot be established, or ATC has instructed a pilot to contact a FIC, position reports shall be made through the assigned FIC or the nearest communications agency enroute.

When the pilot-in-command of an IFR aircraft is informed that the aircraft has been RADAR IDENTIFIED, position reports over compulsory reporting points are no longer required. Pilots will be informed when to resume normal position reporting.

In order that flight information and alerting service may be provided to all IFR flights outside controlled airspace, pilots should make position reports over all navigation aids along the route of flight to the nearest station having air-to-ground communications capability.

If the time estimate for the next applicable reporting point differs from the previously reported estimate by 3 min or more, a revised estimated time should be reported to the appropriate ATS unit as soon as possible.

In the NCA and ACA, there are special position-reporting procedures for flights tracking outside airways. See RAC 12.6 and 12.7 for further details.

8.2 FUTURE AIR NAVIGATION SYSTEMS 1/A AUTOMATIC DEPENDENT SURVEILLANCE WAYPOINT POSITION REPORTING (FANS 1/A ADS WPR)

8.2.1 ADS WPR

ADS WPR is a service that allows aircraft equipped with FANS 1 (the Boeing implementation of FANS) and FANS A (the Airbus implementation of FANS) to provide certain ATS units with position reports (including intent information) based on information received directly from the FMS. ADS contracts are established with flights that will cause an ADS position report to be downlinked to the appropriate ATS unit as each waypoint along the route of flight is passed. Where available, this service may be used as an alternative to voice reporting by flights that receive appropriate authorization.

This service has been successfully introduced in the NAT region, and non-radar portion of the Edmonton FIR/CTA. Information regarding FANS 1/A ADS WPR in the NAT region is provided in Guidance Material for ATS Data Link Services in North Atlantic Airspace, which is available on the North Atlantic Programme Coordination Office (NAT-PCO) Web site at < <http://www.paris.icao.int/> >.

8.2.2 ATS Facilities Notification (AFN) Logon

An ADS contract is initiated by the ground system in response to an AFN logon received from the aircraft. The AFN logon address for flights entering the Edmonton FIR/CTA is CZEG.

It is important, when initializing the flight management computer (FMC), to ensure the aircraft identification matches the one displayed in the filed ATC flight plan (FP) message. If a flight becomes aware that incorrect flight identification data was provided in the AFN logon, ADS must immediately be terminated and a new AFN logon performed with the correct information.

Flights entering Edmonton ADS airspace from airspace where FANS 1/A ATS data link services are being received do not need to perform another AFN logon to continue participating in ADS WPR. Flights entering Edmonton ADS airspace from airspace where no FANS 1/A ATS data link services are being received should ensure their ADS function is turned on and perform an AFN logon:

- (a) 15 to 45 min prior to entering the airspace; or
- (b) prior to departure if departing airports are adjacent to, or underlying, the airspace.

Flights exiting Edmonton ADS airspace into adjacent airspace where ADS and controller-pilot data link communications (CPDLC) services are offered do not need to perform another AFN logon to continue participating in ADS or to initiate a CPDLC connection.

NOTE: Currently, CPDLC services are not available in the Edmonton FIR. Until CPDLC services are available, flights identifying themselves as CPDLC will be advised “CPDLC SERVICE NOT AVAILABLE IN THE EDMONTON FIR.”

8.2.3 Using ADS WPR

Once the ADS contract has been established by the ground system, ADS reports are sent automatically without notification to, or action required by, the flight crew. In the event that an ADS report is not received, ATC will attempt to contact the flight to obtain the position report via voice. If this occurs, or in the event of ADS WPR service interruptions, aircraft equipment failures or loss of signal coverage, flight crews shall resume voice reporting. Flight crews should be aware of the limitations associated with available aircraft equipment and the signal coverage over the intended route.

Flight crews should not insert non-ATC waypoints in the cleared route of flight. Inserting such waypoints will result in the transmission of unwanted position reports to ATC and may prevent the provision of data required by ATC to provide control services.

If deviations around weather are required, flight crews should establish voice contact and advise ATC of their intentions.

Position reports via voice should be made abeam waypoints until the flight is back on its cleared route.

8.2.4 Aeradio Communications

8.2.4.1 Flight Crew Initial Contact with Edmonton Centre (Flight Is Radar Identified)

Aircraft entering the Edmonton FIR from radar-controlled airspace should not identify themselves as ADS-equipped on initial contact. “A–D–S” after the aircraft call sign should only be used leaving radar coverage and approaching the Edmonton ADS airspace. The Edmonton ACC will advise the aircraft that radar service is terminated. This cancellation of radar service should serve to remind ADS-equipped aircraft to commence using “A–D–S” in conjunction with their call sign.

8.2.4.2 Flight Crew Initial Contact with Edmonton Centre (Flight Is Not Radar Identified)

Flights that are not radar identified when making initial contact with Edmonton Centre should:

1. use “A–D–S” after the aircraft call sign; and
2. not include a voice position report.

Flight crews can expect the reply from Edmonton Centre to include:

1. acknowledgement that the flight is ADS;
2. the advisory “VOICE POSITION REPORTS NOT REQUIRED”; and
3. the assigned frequency for the next station en route.

8.2.4.3 Flight Crew Initial Contact with Gander Radio

Upon initial contact with Gander Radio, flight crews should:

1. use “A–D–S” after the aircraft call sign;
2. not include a voice position report;
3. state the name of the first reporting point;
4. for northbound (polar) flights, state the last point exiting the Edmonton FIR/CTA; and
5. request a SELCAL check, if necessary.

Flight crews can expect the reply from Gander Radio to include:

1. acknowledgement that the flight is ADS;
2. the advisory “VOICE POSITION REPORTS NOT REQUIRED IN THE EDMONTON FIR”;
3. a frequency to monitor;
4. the assigned frequency for the next station en route; and
5. a SELCAL check.

8.2.4.4 Flight Crew Initial Contact with Arctic Radio

Upon initial contact with Arctic Radio, flight crews should:

1. use “A–D–S” after the aircraft call sign; and
2. not include a voice position report.

Flight crews can expect the reply from Arctic Radio to include:

1. acknowledgement that the flight is ADS;
2. the advisory “VOICE POSITION REPORTS NOT REQUIRED IN THE EDMONTON FIR”;
3. a frequency to monitor; and
4. the assigned frequency for the next station en route.

8.2.5 Satellite Communications (SATCOM) Shadow

The airspace where ADS WPR will be conducted is affected by an area of satellite communication (SATCOM) unreliability (see map below). This area, referred to as the SATCOM shadow, extends from the North Pole to 70°N. Unreliability is most pronounced at 120°W, where the two satellites servicing the area are furthest away. Coverage improves to the east and west of 120°W, where reliable coverage can be expected as far north as 80°N at 80°W. The exact extent and effect of the shadow depends on atmospheric conditions, aircraft antenna placement, and direction of flight.

Aircraft observing an indication that SATCOM has been lost should expect that their ADS reporting has been terminated. Flight crews can re-login to CZEG if it is felt that the outage has been overcome. Otherwise, ensuing position reports must be provided.

Figure 8.1 – SATCOM Shadow

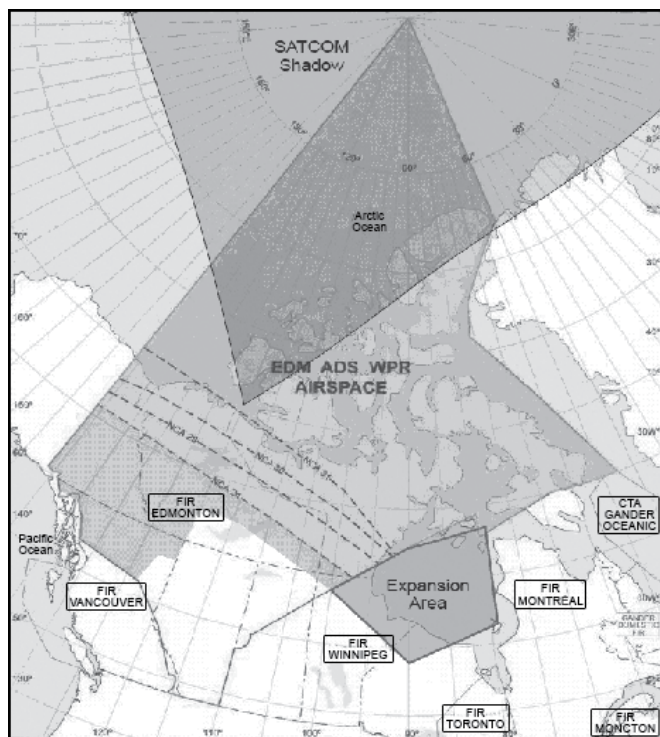

8.3 MACH NUMBER/TRUE AIRSPEED—CLEARANCES AND REPORTS

8.3.1 Mach Number

Clearances to turbojet aircraft equipped with a Machmeter may include an appropriate Mach number. If the Mach number cannot be adhered to, ATC is to be so informed when the clearance is issued. Once accepted, the Mach number shall be adhered to within .01 Mach, unless ATC approval is obtained to make a change. If an immediate temporary change in Mach number is necessary (e.g. because of turbulence), ATC must be notified as soon as possible. When a Mach number is included in a clearance, the flight concerned should transmit its current Mach number with each position report.

8.3.2 TAS

ATC is to be notified as soon as practicable of an intended change to the TAS at the cruising altitude or flight level, where the change intended is five percent or more of the TAS specified in the IFR flight plan or flight itinerary.

8.4 ALTITUDE REPORTS

Although the CARs do not specifically direct pilots to report altitude information to ATC, pilots, if not operating in radar airspace (i.e. radar-identified by ATC), should report reaching the altitude to which the flight has been initially cleared. When climbing or descending en route, pilots should report when leaving a previously-assigned altitude and when reaching the assigned altitude.

On initial contact with ATC, or when changing from one ATC frequency to another, when operating in radar or non-radar airspace, pilots of IFR and CVFR flights should state the assigned cruising altitude and, when applicable, the altitude through which the aircraft is climbing or descending.

In order for ATC to use Mode C altitude information for separation purposes, the aircraft Mode C altitude readout must be verified. The Mode C altitude is considered valid if the readout value does not differ from the aircraft reported altitude by more than 200 ft. The readout is considered invalid if the difference is 300 ft or more. Therefore, it is expected that pilot altitude reports, especially during climbs and descents, will be made to the nearest 100-ft increment.

Example:

EDMONTON CENTRE AIR CANADA 801 HEAVY, LEAVING 8 300 FEET, CLIMBING TO FLIGHT LEVEL 350.

If the phrase “report reaching”, “report leaving” or “report passing” is used by ATC, the pilot shall comply (CAR 602.31—*Compliance with Air Traffic Control Instructions and Clearances*).

8.5 CLIMB OR DESCENT

8.5.1 General

During any phase of flight, pilots should adhere to the following procedures:

- (a) When an altitude clearance is issued, the pilot should begin the climb or descent promptly on acknowledgement of the clearance. The climb or descent should be made at an optimum rate consistent with the operating characteristics of the aircraft. If the above is not the case, or if it becomes necessary to stop the climb or descent, the pilot should advise ATC of the interruption or the delay in vacating an altitude.
- (b) If the phrase “when ready” is used in conjunction with an altitude clearance or instruction, the change of altitude may be initiated whenever the pilot wishes. The climb or descent should be made at an optimum rate consistent with the operating characteristics of the aircraft. Pilots are expected to advise ATC when the altitude change is initiated. Compliance with assigned or published altitude crossing restrictions and speeds is mandatory (CAR 602.31—*Compliance with Air Traffic Control Instructions and Clearances*), unless specifically cancelled by ATC. (MEAs are not considered restrictions; however, pilots are expected to remain at or above MEAs.)

When an aircraft reports vacating an altitude, ATC may assign the altitude to another aircraft. Control will be based on the pilot following these procedures and on the normal operating characteristics of the aircraft.

If a descending aircraft must level off at 10 000 ft ASL to comply with CAR 602.32—*Airspeed Limitations* while cleared to a lower level, the pilot should advise ATC of the descent interruption .

- (c) ATC may authorize aircraft to employ cruise climb techniques either between two levels or above a specified level. A clearance or instruction to cruise climb authorizes climb at any given rate as well as temporary levelling at intermediate altitudes. Pilots are expected to advise ATC of the altitude they temporary level off at to the nearest 100 ft. Once the aircraft has vacated an altitude during a cruise climb, it may not return to that altitude. ATC will use the following phraseology:

CRUISE CLIMB TO (altitude)

or

*CLIMB TO (altitude) CRUISE CLIMB BETWEEN (levels)
(or ABOVE [level])*

8.5.2 Visual Climb and Descent

8.5.2.1 General

Application of visual climbs and descents in VMC, under certain circumstances, provides both controllers and pilots with an operational advantage in the conduct of safe and orderly flow of air traffic.

8.5.2.2 Visual Separation from Other Aircraft

ATC may authorize the pilot of an IFR aircraft to conduct a visual climb or descent while maintaining visual separation with the appropriate traffic only if a pilot requests it. Controllers will not initiate or suggest a visual climb/descent in this application. During this altitude change in VMC, pilots must provide their own separation, including wake turbulence separation, from all other aircraft. This application may be exercised in both radar and non-radar environments.

IFR separation is required for all altitude changes in Class A and B airspace. Accordingly, visual climbs or descents will not be approved for aircraft operating in these classes of airspace.

8.6 MINIMUM IFR ALTITUDES

Except when taking off or landing, aircraft in IFR flight shall be operated at least 1 000 ft above the highest obstacle within a horizontal radius of 5 NM of the aircraft (CAR 602.124). Exceptions to this are flights within designated mountainous regions, but outside areas for which minimum altitudes for IFR operations have been established (see RAC 2.12 and RAC Figure 2.11).

NOTE: The established MOCA for IFR operations provides obstacle clearance above the highest obstacle within the following areas:

- (a) 1 000 ft:
 - (i) airways and air routes outside of designated mountainous areas;
 - (ii) certain airway and air route segments within designated mountainous areas, which are used in the arrival or departure phase of flight;
 - (iii) Safe Altitude 100 NM outside of designated mountainous areas;
 - (iv) all MSA;
 - (v) instrument approach transitions (including DME arcs);
 - (vi) radar vectoring areas [except as in (c)(iii)]; and
 - (vii) AMA outside of designated mountainous areas as shown on the Enroute and Terminal Area Charts.
- (b) 1 500 ft:
 - (i) airways and air routes within designated mountainous areas 2, 3, and 4; or
 - (ii) Safe Altitude 100 NM within designated mountainous areas 2, 3, and 4.

- (c) 2 000 ft:
- (i) airways and air routes within designated mountainous areas 1 and 5 with the exception of those segments described in (a)(ii);
 - (ii) Safe Altitude 100 NM within designated mountainous areas 1 and 5;
 - (iii) certain radar vectoring areas within designated mountainous areas; and
 - (iv) AMA within designated mountainous areas as shown on the Enroute and Terminal Area Charts.

MEAs have been established for all designated low-level airways and air routes in Canada. An MEA is defined as the published altitude ASL between specified fixes on airways or air routes, which assures acceptable navigational signal coverage, and which meets IFR obstacle clearance requirements.

The minimum flight plan altitude shall be the nearest altitude or flight level consistent with the direction of flight (CAR 602.34). This altitude should be at or above the MEA. Unless the MEA is one which is consistent with the direction of flight, it is not to be used in the flight plan or flight itinerary.

As different MEAs may be established for adjoining segments of airways or air routes, aircraft are, in all cases, to cross the specified fix at which a change in the MEA takes place, at the higher MEA.

To ensure adequate signal coverage, many of the MEAs on low-level airways are established at altitudes which are higher than those required for obstacle clearance. When this occurs, a MOCA is also published to provide the pilot with the minimum IFR altitude for obstruction clearance. A MOCA is defined as the altitude between radio fixes on low-level airways, which meets the IFR obstruction clearance requirements for the route segment. Where the MOCA is lower than the MEA, the MOCA is published in addition to the MEA on the Enroute Charts. Where the MEA and MOCA are the same, only the MEA is published.

The MOCA, or the MEA when the MOCA is not published, is the lowest altitude for the airway or air route segment at which an IFR flight may be conducted under any circumstances. These altitudes are provided so that pilots will be readily aware of the lowest safe altitude that may be used in an emergency, such as a malfunctioning engine or icing conditions. Under ISA conditions, they provide a minimum of 1 000 ft of clearance above all obstacles lying within the lateral limits of all airways and air routes, including those in designated mountainous regions.

Pressure altimeters are calibrated to indicate true altitude under ISA conditions, and any deviation from ISA will result in an erroneous altimeter reading. When temperatures are extremely cold, true altitudes will be significantly lower than indicated altitudes. Although pilots may fly IFR at the published MEA/MOCA, in the winter, when air temperatures

are much lower than ISA, they should operate at altitudes of at least 1 000 ft above the MEA/MOCA.

NOTE: When flying at a flight level in an area of low pressure, the true altitude will always be lower than the corresponding flight level. For example, this “pressure error,” in combination with a temperature error, can produce errors of up to 2 000 ft while flying in the standard pressure region at FL100. Further, mountain waves in combination with extremely low temperatures may result in an altimeter over-reading by as much as 3 000 ft. For further details, see AIR 1.5.

8.7 ATC ASSIGNMENT OF ALTITUDES

8.7.1 Minimum IFR Altitude

Within controlled airspace, ATC is not permitted to approve or assign any IFR altitude below the minimum IFR altitude. To ATC, the minimum IFR altitude is the lowest IFR altitude established for use in a specific airspace and, depending on the airspace concerned, this may be:

- (a) a minimum enroute altitude (MEA);
- (b) a minimum obstruction clearance altitude (MOCA);
- (c) a minimum sector altitude (see Note);
- (d) a safe altitude 100 NM (see Note);
- (e) an area minimum altitude (AMA) (see Note); or
- (f) a minimum vectoring altitude.

A controller is not permitted to clear an aircraft flying on an airway at an altitude below the MEA. However, flight below the MEA, but not below the MOCA, may be approved when specifically requested by the pilot in the interest of flight safety (e.g.: icing/turbulence), to conduct a flight check, for MEDEVAC, or when navigating using GPS.

Navigational signal coverage is not guaranteed below the MEA; when navigating using NAVAIDS, the pilot should ensure that the aircraft is within, and will remain within, the lateral limits of the airway before requesting approval to fly below the MEA. It should also be noted that flight below the MEA does not guarantee the aircraft will remain in controlled airspace.

8.7.1.1 DME Intersections on a Minimum En-Route Altitude

The purpose of these fixes is to develop an airway segment where lower MEAs may be applied, thus reducing the high descent rates that otherwise are required when on initial approach to destination.

Pilots without DME normally will not be able to use these lower MEAs and may conceivably experience delays in receiving approach and departure clearances due to other traffic operating below the conventional MEA (i.e., the MEA required for non-DME equipped aircraft). However, in a radar environment, the non-DME equipped aircraft may be cleared at the lower MEA where it will be provided with radar service while operating below the conventional MEA.

8.7.2 Altitudes and Direction of Flight

Pilots will normally file flight plans and be assigned altitudes appropriate to the airway, air route or direction of flight. There are exceptions, and the following information is intended to familiarize pilots with the circumstances of those exceptions.

ATC may assign an altitude that is not appropriate to the airway, air route or direction of flight if:

- (a) a pilot requests it because of icing, turbulence, or fuel considerations, provided:
 - (i) the pilot informs ATC of the time or location at which an appropriate altitude can be accepted, and
 - (ii) the altitude has been approved by affected units/sectors; or
- (b) an aircraft is:
 - (i) holding, arriving or departing,
 - (ii) conducting a flight inspection of a NAVAID,
 - (iii) operating within an altitude reservation, or
 - (iv) engaged in an aerial survey, mapping flight or test flight; or
- (c) no alternative separation minima can be applied, provided:
 - (i) the altitude has been approved by affected units/sectors, and
 - (ii) the aircraft is cleared to an appropriate altitude as soon as possible; or
- (d) the airspace is structured for a one-way traffic flow.

NOTES 1: In situation (a), the pilot, when able to accept an appropriate altitude, will be requested to advise ATC. In situation (c), the aircraft will be re-cleared to an appropriate altitude as soon as operationally feasible. Due to safety implications, use of altitudes inappropriate for the direction of flight must be limited, and requests must not be made solely for fuel efficiency reasons. Pilots should make requests only to avoid a fuel situation that might cause an otherwise unnecessary refuelling stop short of the flight-planned destination. ATC will not ask the pilot to substantiate a request;

if ATC is unable to approve the request, the controller will state the reason and request the pilot's intention.

- 2: In the application of (a) or (c) in high-level radar-controlled airspace, aircraft at an altitude not appropriate for the direction of flight will be issued radar vectors or offset tracks to establish the aircraft at least 5 NM from the centreline of an airway or published track displayed on the radar.

Phraseology:

VECTORS TO (direction) OF (airway, track) TURN (left/right) TO HEADING (degrees).

ADVISE IF ABLE TO PROCEED PARALLEL OFFSET.

PROCEED OFFSET (number) MILES (right/left) OF CENTRELINE (track/route) AT (significant point/time) UNTIL (significant point/time).

CANCEL OFFSET.

8.8 "1 000-FT-ON-TOP" IFR FLIGHT

1 000-ft-on-top IFR flight may be conducted provided that

- (a) the flight is made at least 1 000 ft above all cloud, haze, smoke, or other formation;
- (b) the flight visibility above the formation is at least three miles;
- (c) the top of the formation is well defined;
- (d) the altitude appropriate to the direction of flight is maintained when cruising in level flight;
- (e) the "1 000-ft-on-top" flight has been authorized by the appropriate ATC unit; and
- (f) the aircraft will operate within Class B airspace at or below 12 500 ft ASL, Class C, D, or E airspace.

NOTES: ATC does not apply separation to aircraft operating 1 000-ft-on-top except in the following conditions:

- 1: at night, separation is applied between an aircraft operating 1 000-ft-on-top and other aircraft if any of the aircraft are holding; and
- 2: between aircraft operating 1 000-ft-on-top and an aircraft operating on an altitude reservation approval.

8.9 CLEARANCES—LEAVING OR ENTERING CONTROLLED AIRSPACE

ATC will use the phrase “while in controlled airspace” in conjunction with the altitude if an aircraft will be entering or leaving controlled airspace. In addition, ATC will specify the lateral point and altitude at which an aircraft is to leave or enter controlled airspace if the instruction is required for separation purposes (see Note).

Example:

LEAVE/ENTER CONTROLLED AIRSPACE (number) MILES (direction) OF (fix) AT (altitude).

LEAVE/ENTER CONTROLLED AIRSPACE AT (altitude).

NOTE: The altitude assigned by ATC need only reflect the minimum safe IFR altitude within controlled airspace. A pilot should be alert to the possibility of a higher minimum safe IFR altitude outside of controlled airspace. If uncertain (or unable to determine) when to enter or leave the area where the higher minima is applied, a request for clearance to maintain an altitude that will accommodate the higher minimum IFR altitude should be made.

8.10 CLEARANCE LIMIT

The clearance limit, as specified in an ATC clearance, is the point to which an aircraft is cleared. Further clearance is delivered to a flight prior to arrival at the clearance limit. However, occasions may arise when this may not be possible. In the event that further clearance is not received, the pilot is to hold at the clearance limit, maintain the last assigned altitude and request further clearance. If communications cannot be established with ATC, the pilot should then proceed in accordance with communications failure procedures as described in RAC 6.3.2.

The responsibility rests with the pilot to determine whether or not a received clearance can be complied with in the event of a communications failure. Under such circumstances, a clearance may be refused, but such refusal should specify acceptable alternatives.

8.11 CLASS G AIRSPACE—RECOMMENDED OPERATING PROCEDURES—EN-ROUTE

When aircraft are manoeuvring in the vicinity of uncontrolled aerodromes or cruising in Class G airspace, the lack of information on the movements of other aircraft operating in close proximity may occasion a potential hazard to all concerned. To alleviate this situation, all pilots are advised that:

- (a) when operating in Class G airspace, they should continuously monitor frequency 126.7 MHz whenever practicable;
- (b) position reports should be made over all NAVAIDs along the route of flight to the nearest station having air-to-ground communications capability. These reports should be made on frequency 126.7 MHz whenever practicable. If it is necessary to use another frequency to establish communications with the ground station, the report should also be broadcast on 126.7 MHz for information of other aircraft in the area. The report should contain present position, track, altitude, altimeter setting in use, next position and ETA;
- (c) immediately before changing altitude, commencing an instrument approach or departing IFR, pilots should broadcast their intentions on 126.7 MHz whenever practicable. Such broadcasts should contain adequate information to enable other pilots to be fully aware of the position and intentions so that they can determine if there will be any conflict with their flight paths;
- (d) at aerodromes where an MF has been designated, arriving pilots shall first broadcast their intentions on 126.7 MHz before changing to the MF. If conflicting IFR traffic becomes evident, this change should be delayed until the conflict is resolved. Pilots departing IFR should broadcast their intentions on 126.7 MHz, in addition to the MF, prior to takeoff; and
- (e) the preceding reporting requirements are considered as the minimum necessary. Pilots are encouraged to make additional reports whenever the possibility of conflicting IFR traffic is suspected. An example would be reporting prior to overflying a facility where cross traffic is probable or where there is a published instrument approach procedure.

NOTE: There is no frequency comparable to 126.7 MHz for use by aircraft equipped only with UHF; however, pertinent UHF traffic information will be relayed on the MF by the flight service specialist.

9.0 INSTRUMENT FLIGHT RULES (IFR) — ARRIVAL PROCEDURES

9.1 ATIS BROADCASTS

If ATIS is available, all pilots should use it to obtain the basic arrival or departure and aerodrome information as soon as it is practicable.

9.2 STANDARD TERMINAL ARRIVAL (STAR), MINIMUM SECTOR ALTITUDE (MSA) AND TERMINAL ARRIVAL AREA (TAA)

The objective of the STAR, the MSA and the TAA depictions is to provide arriving aircraft with a seamless transition from the en route structure to the terminal environment.

Unlike the MSAs and TAAs, the STARs are developed to simplify clearance procedures at higher density airports and are individually depicted in the CAP. The MSA and TAA depictions are also in the CAP, but are found in the plan view of the associated approach chart.

A STAR requires the pilot to follow a predetermined route, whereas the MSA and the TAA are less prescriptive and simply offer safe altitudes to which the pilot can descend before commencing the approach.

Pilots are to review each STAR issued and to follow the procedure as published. If there is any doubt as to what is required, clarification should be obtained from ATC. Pilots are not required to accept a STAR clearance, and, if they are unable to follow it, they should request alternate instructions.

9.2.1 Conventional STAR

A conventional STAR is defined as a STAR that can be flown by a pilot using ground-based NAVAIDs or specified headings. Most conventional STARs end with ATC providing radar. A conventional STAR should be filed on a flight plan. If a conventional STAR is filed, ATC expects the aircraft to fly the STAR track as depicted and, once descent clearance has been received, to comply with any charted altitude restrictions above the assigned altitude, unless specifically cancelled by ATC.

9.2.2 RNAV Equipment

With the widespread deployment of RNAV systems and the advent of GPS-based navigation, greater flexibility is now possible in defined routings, procedures and airspace design. This permits an associated increase in flight safety as well as a potential for significant fuel savings and reduced pilot-controller communications.

Pilots interested in flying RNAV STAR procedures should file them as part of their flight plan and must have the following equipment:

- (a) at least one RNAV system or FMS certified for terminal use that meets either of the following standards:
 - AC 20-130 or later approved, Airworthiness Approval of Navigation or Flight Management Systems Integrating Multiple Navigation Sensors; or
 - AC 20-138 or later approved, Airworthiness Approval of Global Positioning System (GPS) Navigation Equipment for use as a VFR and IFR Supplemental Navigation System, and TSO C129a, Airborne Supplemental Navigation Equipment Using the Global Positioning System (GPS);
- (b) at least one automatic radio-updated inertial reference unit (IRU), if the RNAV system or FMS does not use a GPS sensor;
- (c) a current database containing the waypoints for the RNAV STAR to be flown that can be automatically loaded into the RNAV system or FMS active flight plan;
- (d) a system capable of following the RNAV system or FMS lateral flight path and limiting the cross-track error deviation to $\pm \frac{1}{2}$ the navigation accuracy associated with the procedure or route; and
- (e) an electronic map display.

Where the DTW and FACF are not joined (“open” procedure), there will be a discontinuity in the database flight plan. This has caused problems with some onboard equipment when attempting to link the procedure after receiving the approach clearance prior to the DTW. Therefore, prior to filing an RNAV STAR as part of the flight plan, pilots should have procedures in place to ensure that, when required, they will be able to successfully link the DTW to the FACF.

NOTE: If unable to successfully link the procedure, pilots should advise ATC in order to receive radar vectors to the FACF.

Pilots should also be aware that above 180 knots indicated airspeed (KIAS), turn anticipation might not function properly between the DTW and FACF.

9.2.3 RNAV STAR Procedure

Definition:

An RNAV STAR is an IFR ATC arrival procedure coded in an aircraft FMS database and published in graphic and textual form for use by aircraft appropriately equipped and authorized.

General Procedures

The RNAV STAR defines a lateral route for an aircraft to fly from a significant point along the en-route phase of flight to the approach phase with minimal, or no, ATC intervention. Altitude and speed restrictions may be depicted as required on any RNAV STAR. All charted altitude and speed restrictions, including those at the DTW or FACF, are mandatory unless specifically cancelled by ATC.

Altitude Restrictions

Altitude restrictions may be included in the STAR for terrain and obstacle clearance as well as for operational requirements. Although an aircraft is expected to follow the charted lateral track of the cleared STAR without further ATC clearance, such is not the case with the vertical profile. ATC will issue descent clearance, and once a lower altitude is issued by ATC, the pilot shall descend on the STAR profile to the assigned altitude. The pilot will comply with all charted altitude restrictions above the ATC-assigned altitude, unless specifically cancelled by ATC. When an approach clearance is received, all altitude restrictions on the STAR profile remain mandatory, unless specifically cancelled by ATC.

Example:

An aircraft maintaining 12 000 ft is cleared to descend to 6 000 ft and the next two waypoints along the RNAV STAR route have altitude restrictions of 9 000 ft or above and 7 000 ft or above, respectively. The aircraft must cross the first waypoint at 9 000 ft or above and the next at 7 000 ft or above while descending to the ATC-assigned altitude of 6 000 ft. If the aircraft is cleared for the instrument approach in this example, the 9 000-ft and 7 000-ft restrictions remain mandatory, unless specifically cancelled by ATC.

Examples of ATC cancelled restrictions:

DESCEND TO (altitude), ALL STAR ALTITUDE RESTRICTIONS CANCELLED.

DESCEND TO (altitude), ALTITUDE RESTRICTION AT (fix) CANCELLED.

Speed Restrictions

Speed restrictions may be included on the RNAV STAR for operational reasons or because of design criteria. Similar to altitude restrictions, all speed restrictions are mandatory, unless specifically cancelled by ATC. The speed restriction depicted at all DTWs (maximum 200 kt) is also mandatory even after an approach clearance has been issued. It is the pilot's responsibility to adhere to all charted speed restrictions, unless specifically cancelled by ATC.

Flight Planning

Any authorized aircraft and crew meeting the RNAV equipment list (see RAC 9.2.2) may file the RNAV STAR in their flight plan. When included in a flight plan, the RNAV STAR forms part of the flight-planned route received in the initial ATC clearance. When a flight plan that includes an RNAV STAR has been filed, or the pilot receives and acknowledges a clearance that includes an RNAV STAR, the pilot is expected to fly the charted lateral track, without further clearance, from the entry point of the RNAV STAR to the end point (FACF or DTW). However, descent clearance must be obtained from ATC before commencing the vertical profile and, when a lower altitude or approach clearance is received, all charted altitude and speed restrictions remain mandatory, unless specifically cancelled by ATC.

Cancelling an RNAV STAR

An RNAV STAR may be cancelled by ATC, if required. Receipt of a visual approach clearance automatically cancels the STAR procedure. An RNAV STAR that has been cancelled may be reinstated if ATC or the pilot wishes the aircraft to resume the STAR.

Examples:

STAR CANCELLED, FLY HEADING ZERO ONE ZERO FOR VECTORS TO FINAL.

STAR CANCELLED, PROCEED DIRECT HALIFAX V-O-R, EXPECT VISUAL APPROACH RUNWAY THREE TWO.

Amended Routes

ATC may amend (shorten) RNAV STAR routes by clearing the aircraft direct to an intermediate waypoint depicted within the RNAV STAR. ATC will confirm what to expect and the status of the STAR if initiating radar vectors or clearance via a waypoint that is not part of the RNAV STAR. If an amended route bypasses a fix over which there is a published altitude restriction then the altitude restriction at that fix is automatically cancelled.

Examples:

PROCEED DIRECT ROCTO, RESUME WATERLOO TWO ARRIVAL, CROSS ROCTO AT SIX THOUSAND OR ABOVE.

FLY HEADING THREE ONE ZERO FOR SEQUENCING, EXPECT DIRECT VERKO (when vectors terminate), PROCEED DIRECT VERKO RESUME YOUTH TWO ARRIVAL.

ALTITUDE RESTRICTION AT TETOS CANCELLED, PROCEED DIRECT ROCTO, CROSS ROCTO AT ONE ONE THOUSAND.

RNAV STAR Procedures

There are two types of RNAV STAR procedures: open and closed.

Open RNAV STAR Procedures

An open RNAV STAR terminates at a DTW. This procedure is used for aircraft approaching the active runway via the downwind leg to the DTW.

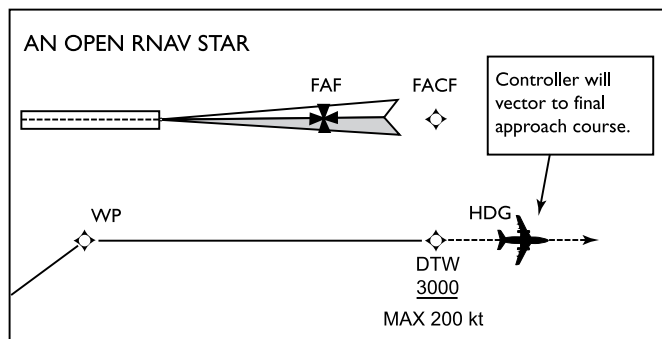

An open RNAV STAR procedure provides a continuous track from the en-route structure via the RNAV STAR entry point to the DTW. Unless specifically cancelled by ATC, all charted altitude and speed restrictions are mandatory, even when a lower altitude or approach clearance is received from ATC. The pilot shall comply with all ATC-assigned altitudes in accordance with ATC clearances received and acknowledged. ATC may close the RNAV STAR by issuing an approach clearance at least 3 NM prior to the DTW. When the approach clearance is issued, the pilot shall comply with charted altitude and speed restrictions and fly the RNAV STAR track to the DTW, then to the FACF (turn anticipation), intercept the final approach course and conduct a straight-in approach. This procedure does not include a procedure turn. If an approach clearance is not received prior to the DTW, the pilot shall maintain the charted heading after the DTW and ATC will provide vectors to a point from which the aircraft can fly the straight-in approach. ATC may, after the DTW, clear the aircraft direct to the FACF for the straight-in approach.

Closed RNAV STAR Procedures

A closed RNAV STAR terminates at an FACF. This procedure is normally used when the inbound track is within plus or minus 90° of the final approach course to the runway.

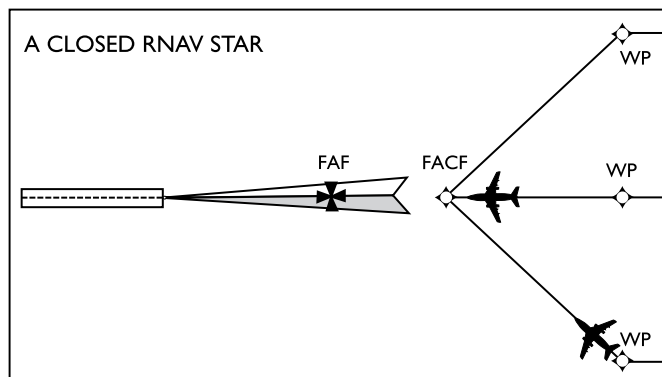

A closed RNAV STAR procedure provides a continuous track from the en-route structure via the RNAV STAR entry point to the FACF. Unless specifically cancelled by ATC, all charted altitude and speed restrictions are mandatory, even when a lower altitude or approach clearance is received. The pilot

shall comply with all ATC-assigned altitudes in accordance with ATC clearances received and acknowledged. When an approach clearance is received, the pilot shall comply with all published altitude and speed restrictions and fly the charted track to the FACF, intercept the final approach course, and fly the straight-in approach. This procedure does not include a procedure turn.

Communications Failures

If communications with ATC cannot be maintained or established, the pilot is expected to indicate a loss of communication (squawk 7600) and, except if following the procedure for two-way communications failure in VMC, as described in RAC 6.3.2.2(a), fly the lateral route of the RNAV STAR associated with the active runway. The pilot is expected to comply with all assigned or charted altitudes and speeds and conduct an approach as indicated below.

Open Procedure

If a communication failure occurs prior to the DTW, the pilot is expected to select transponder code 7600 and, unless alternative instructions or clearances have been received from ATC, continue to the DTW, then to the FACF, intercept the final approach course, and fly the straight-in approach. All charted altitude and speed restrictions remain mandatory. All approaches from RNAV STARs are to be conducted as straight-in procedures with no associated procedure turns.

If a communication failure occurs after the aircraft has passed the DTW, the pilot is expected to select transponder code 7600 and, unless alternative instructions or clearances have been received from ATC, proceed direct to the FACF, and fly the straight-in approach. All charted altitude and speed restrictions remain mandatory. All approaches from RNAV STARs are to be conducted as straight-in procedures with no associated procedure turns.

Closed Procedure

If a communication failure occurs prior to reaching the FACF, the pilot is expected to select transponder code 7600 and, unless alternative instructions or clearances have been received from ATC, continue on the RNAV STAR route to the FACF, intercept the final approach course, and fly the straight-in approach to the active runway. All charted altitude and speed restrictions remain mandatory. All approaches from RNAV STARs are to be conducted as straight-in procedures with no associated procedure turns.

9.2.4 MSA

The MSA, as depicted on the approach chart (see the CAP), provides a minimum of 1 000 ft clearance above all obstacles within a sector of a circle having a radius of at least 25 NM centred on a radio aid to navigation or on a waypoint located near the aerodrome. Where required, the depiction may be divided into several pie-shaped sectors of varying minimum altitudes. Pilots can locate their sector by superimposing their track to the selected NAVAID onto the MSA depiction.

Unlike TAA depictions, MSA depictions do not allow the sectors to be further partitioned into step-down arcs of varying distances.

NOTE: RNAV approaches may use either an MSA or a TAA depiction. RNAV approaches that use the MSA shall depict the common minimum altitude only.

9.2.5 TAA

TAAAs are developed for aircraft equipped with an FMS and/or a GNSS.

When a TAA is published, it replaces the MSA depiction on the approach chart (see the CAP).

The main advantage of the TAA over the MSA is that it can allow step-down arcs, based on RNAV distances, within its divided areas. This allows the aircraft to descend to lower minimum altitudes while still providing a minimum clearance of 1 000 ft above all obstacles.

The standard TAA consists of three areas which are defined by the extension of the initial and intermediate approach segments. These are called the straight-in, left-base, and right-base areas.

BASIC “T” APPROACH WITH TAA DEPICTION*

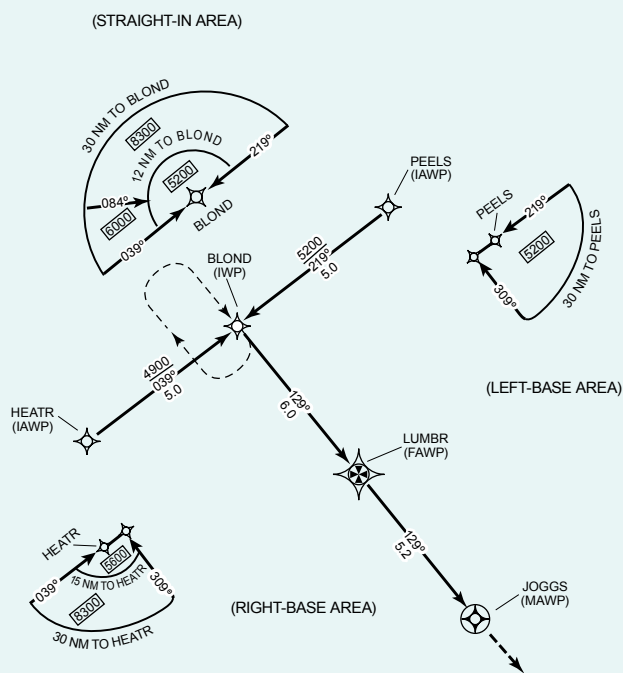

*CAP depiction may be different.

NOTE: The standard “T” design of the approach courses may be modified by the procedure designer where required by terrain or for ATC considerations. For instance, the “T” design may appear more like a regularly or irregularly shaped “Y”, or may even have one or both outboard initial approach waypoints (IAWP) eliminated, resulting in an upside down “L” or an “I” configuration.

Prior to arriving at the TAA boundary, the pilot should determine which area of the TAA the aircraft will enter by selecting the intermediate approach waypoint (IWP) to determine the magnetic bearing TO the waypoint. That bearing should then be compared with the published bearings that define the lateral boundaries of the TAA areas.

CAUTION: Using the end IAWPs (instead of the IWP) may give a false indication of which area the aircraft will enter. This is critical when approaching the TAA near the extended boundary between the left- and right-base areas, especially where these areas contain different minimum altitude requirements.

A standard racetrack holding pattern may be provided at the center IWP/IAWP and, if present, may be necessary for course reversal and for altitude adjustment for entry into the procedure. In the latter case, the pattern provides an extended distance for the descent required by the procedure.

9.3 APPROACH CLEARANCE

When using direct controller pilot communications, ATC normally advises pilots of the ceiling, visibility, wind, runway, altimeter setting, approach aid in use, and pertinent aerodrome conditions (CRFI, RSC, etc.) immediately prior to or shortly after descent clearance. Upon acknowledging receipt of the current ATIS broadcast, the pilot is advised by ATC of the current airport conditions only if they are changing rapidly.

Aircraft destined to airports which underlie controlled low level airspace and for which there is a published instrument approach procedure, will be cleared out of controlled airspace (vertically) via the published instrument approach procedure.

Example:

ATC CLEARS (aircraft identification) OUT OF CONTROLLED AIRSPACE VIA (name, type) APPROACH.

Aircraft destined to airports which underlie controlled low level airspace and for which there is not a published instrument approach procedure will be cleared to descend out of controlled airspace and informed of the appropriate minimum IFR altitude.

Example:

ATC CLEARS (aircraft identification) TO DESCEND OUT OF CONTROLLED AIRSPACE VICINITY OF (aerodrome name). THE (minimum IFR altitude) IS (number) feet.

The pilot may elect to cancel IFR as soon as visual conditions permit the continuation of the flight under VFR, or remain on the IFR flight plan until the aircraft has landed and the pilot files an arrival report (see RAC 3.12.2). Should the pilot anticipate that visual conditions to permit continued flight under VFR may not be achieved, the pilot may arrange with ATC to have the MEA protected, as specified in RAC 9.4.

Aircraft destined to airports which underlie controlled high level airspace and where there is no minimum IFR altitude established that would prohibit such a manoeuvre will be cleared out of controlled high level airspace.

Example:

ATC CLEARS (aircraft identification) OUT OF (type of airspace).

When an approach clearance is issued, the published name of the approach is used to designate the type of approach if adherence to a particular procedure is required. If visual reference to the ground is established before completion of a specified approach, the aircraft should continue with the entire procedure unless further clearance is obtained.

Examples:

CLEARED TO THE OTTAWA AIRPORT, STRAIGHT-IN ILS RUNWAY ZERO SEVEN APPROACH.

CLEARED TO THE TORONTO AIRPORT, ILS RUNWAY ZERO SIX LEFT APPROACH.

The number of the runway on which the aircraft will land is included in the approach clearance when a landing will be made on a runway other than that aligned with the instrument approach aid being used.

Example:

CLEARED TO THE OTTAWA AIRPORT, STRAIGHT-IN ILS RUNWAY ZERO SEVEN APPROACH/CIRCLING PROCEDURE SOUTH FOR RUNWAY THREE TWO.

NOTE: If the pilot begins a missed approach during a circling procedure, the published missed approach procedure as shown for the instrument approach just completed shall be flown. The pilot does not use the procedure for the runway on which the landing was planned.

At some locations during periods of light traffic, controllers may issue clearances that do not specify the type of approach.

Example:

CLEARED TO THE LETHBRIDGE AIRPORT FOR AN APPROACH.

When such a clearance is issued by ATC and accepted by the pilot, the pilot has the option of conducting any published instrument approach procedure. In addition, the pilot also has the option of proceeding by the route so cleared by ATC in a previous clearance, by any published transition or feeder route associated with the selected procedure, or by a route present position direct to a fix associated with the selected instrument approach procedure. Pilots who choose to proceed to the instrument procedure fix via a route that is off an airway, air route or transition are responsible for maintaining the appropriate obstacle clearance, complying with noise abatement procedures and remaining clear of Class F airspace.

As soon as practicable after receipt of this type of clearance, it is the pilot's responsibility to advise ATC of the type of published instrument approach procedure that will be carried out, the landing runway and the intended route to be flown.

This clearance does not constitute authority for the pilot to execute a contact or visual approach. Should the pilot prefer to conduct a visual approach (published or non-published) or a contact approach, the pilot must specifically communicate that request to the controller.

Upon changing to the tower or FSS frequency, pilots should advise the agency of the intended route and published instrument approach procedure being carried out.

The pilot should not deviate from the stated instrument approach procedure or route without the concurrence of ATC because such an act could cause dangerous conflict with another aircraft or a vehicle on a runway.

A clearance for an approach may not include any intermediate altitude restrictions. The pilot may receive this clearance while the aircraft is still a considerable distance from the airport, in either a radar or non-radar environment. In these cases, the pilot may descend, at his/her convenience, to whichever is the lowest of the following IFR altitudes applicable to the position of the aircraft:

- (a) minimum en route altitude (MEA);
- (b) published transition or feeder route altitude;
- (c) minimum sector altitude (MSA) specified on the appropriate instrument approach chart;
- (d) safe altitude 100 NM specified on the appropriate instrument approach chart; or
- (e) when in airspace for which the Minister has not specified a higher minimum, an altitude of at least 1 000 ft above the highest obstacle within a horizontal radius of 5 NM (1 500 ft or 2 000 ft within designated mountainous regions, depending on the zone) from the established position of the aircraft.

NOTE: When a pilot receives and accepts an ATC clearance which authorizes descent to MSA or a safe altitude 100 NM during normal IFR operations, descent below the MEA for the preceding enroute phase should not commence until the pilot can positively establish the aircraft's position by means of a bearing, radial, DME, radar or visual means.

Caution: Pilots are cautioned that descents to MSA or Safe Altitude 100 NM may, under certain conditions, exit controlled airspace. ATC provides IFR separation within controlled airspace only.

9.4 DESCENT OUT OF CONTROLLED AIRSPACE

ATC may not clear an aircraft to operate below the MEA of an airway, nor below the minimum IFR altitude in other controlled low level airspace. The pilot, however, may operate at the MOCA, and ATC will approve flight at the MOCA at the pilot's request. If unable to cancel IFR at the MEA, the pilot may advise that he/she intends to descend to the MOCA. By prior arrangement with ATC, the MEA will be protected in the event that the pilot does not encounter visual conditions at the MOCA. Under this arrangement, the MEA will be protected:

- (a) until the pilot files an arrival report (see RAC 3.12.1);
- (b) for 30 min; to allow descent to the MOCA and return to the MEA when communication is restored with ATC; or
- (c) if ATC does not hear from the pilot under (a) or (b), until the aircraft is estimated to have arrived at the filed alternate plus 30 min.

9.5 ADVANCE NOTICE OF INTENT IN MINIMUM WEATHER CONDITIONS

ATC can handle missed approaches more efficiently if the controller knows the pilot's intentions in advance. They can use the extra time to plan for the possibility of a missed approach and thus provide better service in the event of an actual missed approach.

Pilots should adopt the following procedures as the occasion arises.

On receipt of approach clearance, when the ceiling and visibility reported at the destination airport is such that a missed approach is probable, the pilot should advise the controller as follows:

IN THE EVENT OF MISSED APPROACH REQUEST (altitude or level) VIA (route) TO (airport).

Implementation of this procedure increases the amount of communications, but the increase can be minimized if pilots employ it only when there is a reasonable chance that a missed approach may occur.

9.6 CONTACT AND VISUAL APPROACHES

9.6.1 Contact Approach

A contact approach is an approach wherein an aircraft on an IFR flight plan or flight itinerary having an ATC clearance, operating clear of clouds with at least 1 NM flight visibility and a reasonable expectation of continuing to the destination airport in those conditions, may deviate from the IAP and proceed to the destination airport by visual reference to the surface of the earth. In accordance with CAR 602.124, the aircraft shall be flown at an altitude of

at least 1 000 ft above the highest obstacle located within a horizontal radius of 5 NM from the estimated position of the aircraft in flight until the required visual reference is acquired in order to conduct a normal landing. Pilots are cautioned that conducting a contact approach in minimum visibility conditions introduces hazards to flight not experienced when flying IFR procedures. Familiarity with the aerodrome environment, including local area obstacles, terrain, noise sensitive areas, Class F airspace and aerodrome layout, is paramount for a successful contact approach in minimum visibility conditions. Pilots are responsible for the adherence to published noise abatement procedures and compliance with any restrictions that may apply to Class F airspace when conducting a contact approach.

NOTE: This type of approach will only be authorized by ATC when:

- (a) the pilot requests it; and
- (b) there is an approved functioning instrument approach, a published GPS or a GPS overlay approach for the airport.

An aircraft that requests a contact approach to an airport served only by a GPS approach is indicating to ATS that the pilot understands that no ground based approach is available and is confirming that it is able to conduct a GPS approach.

ATC will ensure IFR separation from other IFR flights and will issue specific missed approach instructions if there is any doubt that a landing will be accomplished. Pilots are cautioned that when any missed approach is initiated while conducting a contact approach, obstacle and terrain avoidance is the pilot's responsibility even though specific missed approach instructions may have been issued by ATC (see RAC 9.26). ATC only ensures appropriate IFR separation from other IFR aircraft during contact approaches.

NOTE: ATC will not issue an IFR approach clearance that includes clearance for a contact approach unless there is a published and functioning IAP or a restricted instrument approach procedure (RIAP) authorized by TC for the airport. Where a GPS or GPS overlay approach is the only available IAP or RIAP, this fulfils the requirement for a "functioning instrument approach."

9.6.2 Visual Approach

A visual approach is an approach wherein an aircraft on an IFR flight plan (FP), operating in VMC under the control of ATC and having ATC authorization, may proceed to the destination airport.

To gain operational advantages in a radar environment, the pilot may request or ATC may initiate a visual approach, provided that:

- (a) the reported ceiling is at least 500 ft above the established minimum IFR altitude and the ground visibility is at least 3 SM;
- (b) the pilot reports sighting the airport (controlled or

- uncontrolled); and
- (c) at a controlled airport:
- (i) the pilot reports sighting the preceding aircraft and is instructed by ATC to follow or maintain visual separation from that aircraft; or
 - (ii) the pilot reports sighting the airport but not the preceding aircraft, in which case ATC will ensure separation from the preceding aircraft until:
 - (A) the preceding aircraft has landed; or
 - (B) the pilot has sighted the preceding aircraft and been instructed to follow or maintain visual separation from it.

ATC considers acceptance of a visual approach clearance as acknowledgement that the pilot should be responsible for:

- (a) at controlled airports, maintaining visual separation from the preceding aircraft that the pilot is instructed to follow or from which the pilot is instructed to maintain visual separation;
- (b) maintaining adequate wake turbulence separation;
- (c) navigating to the final approach;
- (d) adhering to published noise abatement procedures and complying with any restrictions that may apply to Class F airspace; and
- (e) at uncontrolled airports, maintaining appropriate separation from VFR traffic that, in many cases, will not be known to ATC.

A visual approach is not an IAP and therefore has no missed approach segment. If a go-around is necessary for any reason, aircraft operating at controlled airports will be issued an appropriate advisory/clearance/instruction by the tower. At uncontrolled airports, aircraft crews are required to remain clear of clouds and are expected to complete a landing as soon as possible. If a landing cannot be accomplished, the aircraft crew is required to remain clear of clouds, maintain separation from other airport traffic and is expected to contact ATC as soon as possible for further clearance. ATC separation from other IFR aircraft is only assured once further ATC clearance has been received and acknowledged by the aircraft crew.

9.7 RADAR ARRIVALS

9.7.1 General

Radar separation is applied to arriving aircraft in order to establish and maintain the most desirable arrival sequence to avoid unnecessary “stacking”. In the approach phase, radar vectoring is carried out to establish the aircraft on an approach aid. The initial instruction is normally a turn to a heading for radar vectors to a final approach to the runway in use. Should a communications failure occur after this point, the pilot should continue and carry out a straight-in approach if able, or carry out a procedure turn and land as soon as

possible. Aircraft are vectored so as to intercept the final approach course approximately 2 NM from the point at which final descent will begin.

Example:

JULIETT WHISKEY CHARLIE, TURN LEFT HEADING ONE SEVEN ZERO TO INTERCEPT FINAL APPROACH COURSE. SEVEN MILES FROM AIRPORT. CLEARED FOR STRAIGHT-IN ILS RUNWAY ONE FIVE LEFT APPROACH. CONTACT TORONTO TOWER ON ONE ONE EIGHT DECIMAL SEVEN NOW.

9.7.2 Radar Required

Traditionally, instrument approach procedures have been developed to include a procedure turn initial approach segment. Procedure turns permitted the pilot to “selfnavigate” the aircraft within the procedure in order to place the aircraft in a position to conduct a normal landing. Introducing DME and other feeder routes or transitions permitted the pilot to conduct a straight-in procedure without conducting the procedure turn. Most instrument procedures today are accomplished without conducting a procedure turn.

Instrument approaches at Canada’s major airports are conducted by radar vectors to the final approach course. While procedure turns are depicted on the instrument approach procedures at these airports, procedure turns are never flown. ATC route and space all aircraft within the terminal area in order to provide a systematic flow of the air traffic. An aircraft conducting a procedure turn manoeuvre at these major centres would cause serious traffic disruptions which may lead to losses of separation or possibly a mid-air collision.

Instrument procedures are being introduced eliminating the procedure turn as well as including a statement “RADAR REQUIRED” as part of the procedure. The initial approach segment of these instrument procedures is being provided by ATC radar vectors. Without ATC radar vectoring, the instrument procedure may not have a published initial approach segment.

Should an aircraft communication failure occur while being vectored for one of these approaches, refer to the communications failure procedures detailed in RAC 6.3.2.

9.7.3 Speed Adjustment – Radar-Controlled Aircraft

NOTE: This section is for information only. It describes directives to controllers and in no way alters the applications of CAR 602.32, which prescribes the following maximum speeds for all aircraft:

- below 10 000 feet ASL, 250 kt; and
- below 3 000 feet AGL and within 10 NM of controlled airports, 200 kt.

To assist with radar vectoring, it is sometimes necessary to issue speed adjustments. While ATC will take every precaution not to request speeds beyond the capability of the aircraft, it is the pilot's responsibility to ensure that the aircraft is not operated at an unsafe speed. If ATC issues a speed reduction that is inconsistent with safe operation, the pilot must inform ATC when unable to comply.

Speed adjustment will be expressed in units of 10 kt or multiples of 10 kt based on the indicated airspeed (IAS). Pilots complying with a speed adjustment are expected to maintain a speed within 10 kt of the specified speed.

Pilots may be asked to:

- (a) maintain present speed; or
- (b) increase or reduce speed to a specified speed or by a specified amount.

Unless prior concurrence in the use of a lower speed is obtained from the pilot, the following minimum speeds will be applied to:

- (a) aircraft operating 20 NM or more from destination airport:
 - (i) at or above 10 000 feet ASL: 250 kt IAS; and
 - (ii) below 10 000 feet ASL: 210 kt IAS;
- (b) turbojet aircraft operating less than 20 NM from destination airport: 160 kt IAS; and
- (c) propeller-driven aircraft operating less than 20 NM from destination airport: 120 kt IAS.

Pilots of aircraft that cannot attain speeds as high as the minimum speeds specified may be requested to:

- (a) maintain a specified speed equivalent to that of a preceding or succeeding aircraft; or
- (b) increase or decrease speed by a specified amount.

The issuance of an approach clearance normally cancels a speed adjustment; however, if the controller requires that a pilot maintain a speed adjustment after the issuance of the approach clearance, the controller will restate it. Otherwise, ATC may use the phrase "resume normal speed" to advise a pilot that previously issued speed restrictions are cancelled. Unless specifically stated by ATC, an instruction to "resume normal speed" does not cancel speed restrictions that are applicable to published procedures of upcoming segments of flight.

9.7.4 Precision Radar Approaches

- (a) Precision Radar Approaches (PARs) are provided at aerodromes with military PAR units. The aircraft is vectored by surveillance radar to a predetermined position, at which point control is transferred to the PAR controller for the approach.

Example:

JULIETT WHISKEY CHARLIE, EIGHT MILES FROM AIRPORT, TURN LEFT HEADING TWO SEVEN ZERO FOR FINAL APPROACH. CLEARED FOR PRECISION RADAR APPROACH RUNWAY TWO FOUR. CONTACT TRENTON PRECISION ON ONE TWO EIGHT DECIMAL SEVEN NOW.

- (b) In an emergency, where surveillance radar coverage permits it, air traffic controllers will provide a surveillance radar approach if no alternative method of approach is available and the pilot declares an emergency and requests a radar approach.

NOTE: NAV CANADA radars are not flight-checked or commissioned for surveillance approaches, nor are NAV CANADA controllers specifically trained to provide them.

9.8 INITIAL CONTACT WITH CONTROL TOWERS

Pilots should establish contact with the control tower as follows:

- (a) If in direct communication with an ACC or a TCU, the IFR controller shall advise the pilot when contact is to be made with the tower. Unless on radar vectors to final approach, pilots should give the tower their ETA to the facility for the approach they intend to fly.
- (b) If the conditions above do not apply, pilots should establish communication with the tower when approximately 25 NM from the airport, give their ETA, obtain an ATC approach clearance (if not already received), advise approach intentions and remain on tower frequency.

NOTE: Whenever an ETA is passed, the pilot should specify the point, fix or facility to which the ETA applies.

9.9 APPROACH POSITION REPORTS—CONTROLLED AIRPORTS

Pilots conducting an instrument approach to, or landing at, a controlled airport should only make position reports that are requested by the appropriate ATC unit. As an example, pilots may expect ATC to request a report by the Final Approach Fix (FAF) or a specified distance on final. Position reports made under these circumstances are expected to be stated by reporting the position only.

9.10 CONTROL TRANSFER— IFR UNITS TO TOWERS

Tower controllers may accept responsibility for control of an arriving IFR flight within the CZ if VMC exist at an airport, and the aircraft has been sighted and will remain in sight. The transfer of control to the tower does not cancel the IFR flight plan, but rather indicates that the aircraft is now receiving airport control service. In such instances, IFR separation minima may not continue to be applied. The tower controller may use visual separation procedures, or issue clearances and instructions as necessary to maintain a safe, orderly and

expeditious flow of airport traffic. Occasionally the tower controller may issue instructions that supersede previous instructions and clearances that the pilot had received from the IFR unit. Acknowledgement of these instructions indicates to the tower that the pilot shall comply with them. A pilot must not assume that the control tower has radar equipment or that radar service is being provided.

9.11 INITIAL CONTACT WITH AIR-TO-GROUND (A/G) FACILITY AT UNCONTROLLED AERODROMES

Pilots shall establish communications with the A/G facility (FSS, RCO, CARS or UNICOM) on the appropriate frequency if in direct communication with an ACC or a TCU, when directed to do so by the ACC or TCU.

Notwithstanding this, in accordance with CAR 602.104, pilots shall establish communication with the facility on the appropriate frequency no later than five minutes prior to the estimated time of commencing the approach procedure. If the ATC approach clearance has not already been received, it should be obtained from the agency listed on CAP approach charts, unless otherwise directed by ATC.

NOTES 1: If a pilot is instructed to remain on the ATC frequency rather than being transferred to the appropriate frequency for the uncontrolled aerodrome, it remains the pilot's responsibility to notify the associated destination aerodrome ground station, or to broadcast where no ground station exists, and report in accordance with RAC 9.12(a). This may be accomplished by taking one of the following actions:

- (a) if the aircraft is equipped with more than one two-way communication radio, the pilot is expected to make the report on the appropriate frequency with the secondary radio, while monitoring the ATC frequency on the primary radio; or
 - (b) if the aircraft is equipped with a single two-way communication radio, the pilot must first request and receive permission to leave the ATC frequency in order to transmit this directed or broadcast report and then return to the ATC frequency; or, if this is not possible, the pilot should specifically request ATC to notify the associated ground station of their approach intentions and estimated time of landing.
- 2: At aerodromes where RAAS is provided via an RCO and where AWOS (or LWIS) weather information is also broadcast via a voice generator module (VGM), it is recommended that pilots listen to the broadcast prior to contacting the A/G facility, and upon contact, advise that they have the wind and altimeter information.

Because a VGM weather broadcast contains up-to-the-minute weather, it will be more current and may differ slightly from the most recently disseminated aviation routine weather report (METAR) or aviation selected special weather report (SPECI). The latest METAR or SPECI for the remote aerodrome will be provided, upon request, from the ATS unit controlling the RCO.

9.12 REPORTING PROCEDURES FOR IFR AIRCRAFT WHEN APPROACHING OR LANDING AT AN UNCONTROLLED AERODROME (CAR 602.104) (SEE RAC 4.5.4 AND 4.5.5)

The pilot-in-command of an IFR aircraft who intends to conduct an approach to or a landing at an uncontrolled aerodrome, whether or not the aerodrome lies within an MF area, shall report:

- (a) the pilot-in-command's intentions regarding the operation of the aircraft
 - (i) five minutes before the estimated time of commencing the approach procedure, stating the estimated landing time,
 - (ii) when commencing a circling manoeuvre, and
 - (iii) as soon as practicable after initiating a missed approach procedure; and
- (b) the aircraft's position
 - (i) when passing the fix outbound, when the pilot-in-command intends to conduct a procedure turn, or, if no procedure turn is intended, when the aircraft first intercepts the final approach course,
 - (ii) when passing the final approach fix or three minutes before the estimated landing time where no final approach fix (FAF) exists, and
 - (iii) on final approach.

In addition to these requirements, pilots operating aircraft under IFR into an uncontrolled aerodrome, when the weather conditions at the aerodrome could permit VFR circuit operations, are expected to approach and land on the active runway that may be established by the aircraft operating in the VFR circuit. Pilots operating aircraft under IFR at an uncontrolled aerodrome do not establish any priority over aircraft operating under VFR at that aerodrome. Should it be necessary for the IFR aircraft to approach to and/or land on a runway contrary to the established VFR operation, it is expected that appropriate communications between pilots, or pilots and the air-to-ground facility, will be effected in order to ensure there is no conflict of traffic.

9.13 IFR PROCEDURES AT AN UNCONTROLLED AERODROME IN UNCONTROLLED AIRSPACE

Pilots operating under IFR in uncontrolled airspace should, whenever practical, monitor 126.7 MHz and broadcast their

intentions on this frequency immediately prior to changing altitude or commencing an approach. Therefore, when arriving at an aerodrome where another frequency is designated as the MF, descent and approach intentions should be broadcast on 126.7 MHz before changing to the MF. If conflicting IFR traffic becomes evident, this change should be delayed until the conflict is resolved. Once established on the MF, the pilot shall make the reports listed in RAC 9.12 (see RAC 4.5.4 for MF procedures, and RAC 4.5.5 for the use of 123.2 MHz where a UNICOM does not exist).

A straight-in landing from an IFR approach should not be used at an uncontrolled aerodrome where air-ground advisory is not available to provide the wind direction and speed and runway condition reports required to conduct a safe landing. The pilot should determine the wind and verify that the runway is unobstructed before landing. Where pilots lack any necessary information, they are expected to ensure that a visual inspection of the runway is completed prior to landing. In some cases, this can only be accomplished by conducting a circling approach using the appropriate circling MDA.

Pilots operating aircraft under IFR into an uncontrolled aerodrome in uncontrolled airspace when the weather conditions at the aerodrome could permit VFR circuit operations are expected to approach and land on the active runway that may be established by the aircraft operating in the VFR circuit. Pilots operating aircraft under IFR at an uncontrolled aerodrome in uncontrolled airspace do not establish any priority over aircraft operating under VFR at that aerodrome. Should it be necessary for the IFR aircraft to approach to, land, or take off on a runway contrary to the established VFR operation, it is expected that appropriate communications between the pilots, or pilots and the air-to-ground facility, will be effected in order to ensure that there is no conflict of traffic.

9.14 OUTBOUND REPORT

To apply the prescribed separation minima between aircraft intending to make a complete instrument approach procedure and other aircraft, ATC must often establish the position and direction of arriving aircraft with respect to the approach facility. When reporting “outbound”, pilots should make these reports only after they are over or abeam the approach facility and proceeding in a direction away from the airport.

9.15 STRAIGHT-IN APPROACH

ATC uses the term “straight-in approach” to indicate an instrument approach conducted so as to position the aircraft on final approach without performing a procedure turn.

9.16 STRAIGHT-IN APPROACHES FROM AN INTERMEDIATE FIX

Published transitions normally are designated from an en route navigation aid to the primary approach aid upon which the procedure turn is based. However, to accommodate aircraft with modern avionics equipment and to improve fuel economy, transitions at some locations direct the pilot to an intermediate fix (IF) on the final approach course. Subject to ATC requirements and local traffic conditions, a straight-in approach may be made from this fix.

Intermediate fixes are usually located on the final approach track at the procedure turn distance specified in the profile view. This distance, which is normally 10 NM, is the distance within which the procedure turn should be executed. Accordingly, after passing the fix and manoeuvring the aircraft onto the proper inbound track, descent may be made to the appropriate published altitude that would apply as if a procedure turn had been completed.

The abbreviation “NO PT” is used to denote that no procedure turn is necessary from the point indicated and will normally be shown adjacent to the IF. However, if the minimum altitude IF to the final approach fix (FAF) is not readily apparent, the “NO PT” abbreviation may be shown at some point between the fix and FAF, along with an altitude applicable for this segment.

Where more than one transition intersects the final approach track at different points, only the furthest intersection is designated as the IF. Pilots may begin a straight-in approach from any depicted transition that intersects the final approach track inside the designated IF provided that ATC is aware of their intentions and subsequent manoeuvring is within the capabilities of the aircraft.

If the aircraft is badly positioned, laterally or vertically, after being cleared by ATC for the straight-in approach, pilots should climb to the procedure turn altitude, or the minimum altitude at the facility if one is depicted, and proceed to the FAF requesting clearance for a procedure turn.

NOTE: If the FAF is behind the aircraft, the pilot must conduct a missed approach and request further clearance from ATC.

The depiction of radials on a DME arc transition to an IF are normally limited to the radial forming the IAF at the beginning of the arc, the lead radial (if required) to indicate where the turn to the final approach track should be commenced, and radials forming step-down fixes if descent to lower altitudes can be approved. However, the arc may be joined from any radial that intercepts the depicted arc.

9.17 PROCEDURE ALTITUDES AND CURRENT ALTIMETER SETTING

All altitudes published in the CAP are minimum altitudes that meet obstacle clearance requirements when International Standard Atmosphere (ISA) conditions exist and the aircraft altimeter is set to the current altimeter setting for that aerodrome. The altimeter setting may be a local or a remote setting when so authorized on the instrument approach chart. A current altimeter setting is one provided by approved direct reading or remote equipment or by the most recent routine hourly weather report. These readings are considered current up to 90 min from the time of observation. Care should be exercised when using altimeter settings older than 60 min or when pressure has been reported as falling rapidly. In these instances, a value may be added to the published DH/MDA in order to compensate for falling pressure tendency (0.01 inches of mercury = 10-ft correction). Under conditions of extreme cold, corrections to the published altitudes should be applied to ensure adequate obstacle clearance. When an authorized remote altimeter setting is used, the altitude correction shall be applied as indicated.

9.17.1 Corrections for Temperature

The calculated minimum safe altitudes must be adjusted when the ambient temperature on the surface is much lower than that predicted by the standard atmosphere. In such conditions, an approximate correction is four percent height increase for every 10°C below standard temperature, as measured at the altimeter setting source. This is safe for all altimeter setting source altitudes for temperatures above -15°C.

For colder temperatures, a more accurate correction should be obtained from the “Altitude Correction Chart” in the General Pages of CAP (which is reproduced in RAC Figure 9.1). This table is calculated for an aerodrome at sea level. It is, therefore, conservative when applied to aerodromes at higher altitudes. To calculate the reduced corrections for specific aerodrome or altimeter setting sources above sea level, or for values not tabulated, see the paragraphs below.

Figure 9.1—Altitude Correction Chart COLD TEMPERATURE CORRECTIONS

Pressure altimeters are calibrated to indicate true altitude under ISA conditions. Any deviation from ISA will result in an erroneous reading on the altimeter. In a case when the temperature is higher than the ISA, the true altitude will be higher than the Figure indicated by the altimeter, and the true altitude will be lower when the temperature is lower than the ISA. The altimeter error may be significant, and becomes extremely important when considering obstacle clearances in very cold temperatures.

In conditions of extreme cold weather, pilots should add the values derived from the Altitude Correction Chart to the published procedure altitudes, including minimum sector altitudes and DME arcs, to ensure adequate obstacle clearance. Unless otherwise specified, the destination aerodrome elevation is used as the elevation of the altimeter source.

With respect to altitude corrections, the following procedures apply:

1. IFR assigned altitudes may be either accepted or refused. Refusal in this case is based upon the pilot's assessment of temperature effect on obstruction clearance.
2. IFR assigned altitudes accepted by a pilot should not be adjusted to compensate for cold temperatures, i.e., if a pilot accepts “maintain 3 000”, an altitude correction should not be applied to 3 000 ft.
3. Radar vectoring altitudes assigned by ATC are temperature compensated and require no corrective action by pilots.
4. When altitude corrections are applied to a published final approach fix (FAF) crossing altitude, procedure turn or missed approach altitude, pilots should advise ATC how much of a correction is to be applied.

ALTITUDE CORRECTION CHART

Aerodrome Temperature °C	Height above the elevation of the altimeter setting sources (feet)													
	200	300	400	500	600	700	800	900	1 000	1 500	2 000	3 000	4 000	5 000
0	20	20	30	30	40	40	50	50	60	90	120	170	230	290
-10	20	30	40	50	60	70	80	90	100	150	200	290	390	490
-20	30	50	60	70	90	100	120	130	140	210	280	430	570	710
-30	40	60	80	100	120	130	150	170	190	280	380	570	760	950
-40	50	80	100	120	150	170	190	220	240	360	480	720	970	1 210
-50	60	90	120	150	180	210	240	270	300	450	600	890	1 190	1 500

- NOTES** 1: The corrections have been rounded up to the next 10-ft increment.
 2: Values should be added to published minimum IFR altitudes.
 3: Temperature values from the reporting station nearest to the position of the aircraft should be used. This is normally the aerodrome.

Example: Aerodrome Elevation 2 262 ft Aerodrome Temperature -50°C

	ALTITUDE	HAA	CORRECTION	INDICATED ALTITUDE
Procedure Turn	4 000 ft	1 738 ft	+521.4 ft ¹	4 600 ft ²
FAF	3 300 ft	1 038 ft	+311.4 ft	3 700 ft
MDA Straight-in	2 840 ft	578 ft	+173.4 ft	3 020 ft
Circling MDA	2 840 ft	578 ft	+173.4 ft	3 020 ft

¹ CORRECTION derived as follows:
 (2 000 ft at -50° error) 600 – (1 500 ft at -50° error) 450 = 150
 Altitude difference of above (2 000 – 1 500) = 500
 Error per foot difference (150/500) = .3
 HAA = 1 738
 Error at 1 738 = (1 738 – 1 500) * 0.3 = 71.4 + 450 (error -50° at 1 500) = 521.4

² INDICATED ALTITUDE derived as follows:
 Calculated error at 1 738 from above = 521.4
 Procedure-turn altitude (4 000) + error (521.4) = 4 521.4
 INDICATED ALTITUDE rounded next higher 100-ft increment = 4 600

The “Altitude Correction Chart” was calculated assuming a linear variation of temperature with height. It is based on the following equation, which may be used with the appropriate value of t_0 , H , L_0 and H_{ss} to calculate temperature corrections for specific conditions. This equation produces results that are within five percent of the accurate correction for altimeter setting sources up to 10 000 ft and with minimum heights up to 5 000 ft above that source.

$$\text{Correction} = H * ((15 - t_0) / (273 + t_0 - 0.5 * L_0 * (H + H_{ss})))$$

where:

- H = minimum height above the altimeter setting source (the setting source is normally the aerodrome, unless otherwise specified)
- t_0 = $t_{\text{aerodrome}} + L_0 * h_{\text{aerodrome}}$ aerodrome (or specified temperature reporting point) temperature adjusted to sea level
- L_0 = 0.0065°C per metre or 0.00198°C per foot
- H_{ss} = altimeter setting source elevation
- $t_{\text{aerodrome}}$ = aerodrome (or specified temperature reporting point) temperature
- $h_{\text{aerodrome}}$ = aerodrome (or specified temperature reporting point) elevation

For occasions when a more accurate temperature correction is required, this may be obtained from the following formula, which assumes an off-standard atmosphere.

$$\Delta h_{\text{CORRECTION}} = \Delta h_{\text{Pircraft}} - \Delta h_{\text{Gaircraft}} = \frac{(-\Delta T_{\text{std}} / L_0) \ln[1 + L_0 * \Delta h_{\text{Pircraft}} / (T_0 + L_0 * h_{\text{P aerodrome}})]}{}$$

where:

- $\Delta h_{\text{Pircraft}}$ = aircraft height above aerodrome (pressure)
- $\Delta h_{\text{Gaircraft}}$ = aircraft height above aerodrome (geopotential)
- ΔT_{std} = temperature deviation from the ISA temperature
- L_0 = standard temperature lapse rate with pressure altitude in the first layer (sea level to tropopause) of the ISA.
- T_0 = standard temperature at sea level

The above equation cannot be solved directly in terms of $\Delta h_{\text{Gaircraft}}$, and an iterative solution is required. This can be done with a simple computer or spreadsheet program.

NOTE: Geopotential height includes a correction to account for the variation of g (average 9.8067 m sec²) with height. However, the effect is negligible at the minimum altitudes considered for obstacle clearance: the difference between geometric height and geopotential height increases from zero at mean sea level to -59 ft at 36 000 ft

Both the above equations assume a constant off-standard temperature lapse rate. The actual lapse rate may vary considerably from the assumed standard, depending on latitude and time of year. However, the corrections derived from the linear approximation can be taken as a satisfactory estimate for general application at levels up to 12 000 ft. The correction from the accurate calculation is valid up to 36 000 ft.

NOTES 1: Where accurate corrections are required for non-standard (as opposed to off-standard) atmospheres, appropriate methods are given in Engineering Sciences Data Unit (ESDU) Item 78012 “Height relationships for non-standard atmospheres.” This allows for non-standard temperature lapse rates and lapse rates defined in terms of either geopotential height or pressure height.

- 2: Temperature values are those at the altimeter setting source (normally the aerodrome). When en route, the setting source nearest to the position of the aircraft should be used.

For practical operational use, it is appropriate to apply a temperature correction when the value exceeds 20 percent of the associated minimum obstacle clearance.

9.17.2 Remote Altimeter Setting

Normally, approaches shall be flown using the current altimeter setting only for the destination aerodrome. However, at certain aerodromes where a local pressure setting is not available, approaches may be flown using a current altimeter setting for a nearby aerodrome. Such an altimeter setting is considered a remote altimeter setting, and authorization for its use is published in the top left-hand corner of the approach chart plan view.

If the use of a remote altimeter setting is required for limited hours only, an altitude correction will be included with the authorization. When the remote altimeter setting is used, the altitude correction shall be applied as indicated. If the use of a remote altimeter setting is required at all times, then the

correction is incorporated into the procedure at the time it is developed.

Examples:

1. When using the Mont-Joli altimeter setting, add 200 ft to all procedure altitudes.
2. Use the London altimeter setting.

If the altitude correction results in the calculated rate of descent to exceed design parameters, the words “circling minima apply” will be added to the note in the top left-hand corner of the approach chart. The intent of this note is to draw attention to the pilot so that he/she cannot use straight-in minima when using the remote altimeter source. However, this does not prohibit the pilot from landing straight in if he/she has adequate visual reference at circling minima and is suitably located to land straight in.

Example:

When using St-Hubert altimeter, add 120 ft to all procedure altitudes; circling minima applies.

9.18 DEPARTURE, APPROACH AND ALTERNATE MINIMA

The civil minima published in the CAP shall, unless otherwise authorized, be observed by all pilots in accordance with their instrument rating as outlined in RAC Figure 9.2. Authorization to operate to special limits may be obtained by air operators in accordance with Part VII of the CARs or by private operators in accordance with subpart 604 of the CARs

9.18.1 Category II ILS Approach Minima

Category II operations are precision approaches in weather minima as low as 100 ft. DH and RVR 1 200 ft. These minima are restricted to aircraft and pilots specifically approved for such operations by TC and to runways specially equipped for the category of operation. Details on Category II requirements are contained in CAR 602.128, *Landing Minima, and the Manual of All Weather Operations (Categories II and III)* (TP 1490E).

Figure 9.2 – Instrument Rating Minima

	AIRCRAFT	ROTORCRAFT
TAKEOFF VISIBILITY	CAP	1/2 CAP but not less than 1/4 SM.
LANDING DH or MDA	CAP	CAP
ALTERNATE WEATHER MINIMA REQUIREMENTS – CAP GEN		
FACILITIES AVAILABLE AT SUITABLE ALTERNATE	WEATHER REQUIREMENTS	
TWO OR MORE USABLE PRECISION APPROACHES Each providing straight-in minima to separate suitable runways.	400 - 1 or 200 - 1/2 above the lowest usable HAT and visibility, whichever is greater.	N/A
ONE USABLE PRECISION APPROACH	600 - 2* or 300-1 above the lowest usable HAT and visibility, whichever is greater.	N/A
NON-PRECISION ONLY AVAILABLE	800 - 2* or 300-1 above the lowest usable HAT/HAA and visibility, whichever is greater.	N/A
NO IFR APPROACH AVAILABLE	Forecast weather must be no lower than 500 ft above a minimum IFR altitude that will permit a VFR approach and landing.	N/A
FOR ROTORCRAFT Where instrument approach procedures are available.	N/A	Ceiling 200 ft above the minima for the approach to be flown, and visibility at least 1 SM but never less than the minimum visibility for the approach to be flown.

9.19 APPLICATION OF MINIMA

9.19.1 Take-Off Minima

CAR 602.126, “Take-off Minima,” specifies that takeoff for all aircraft is governed by visibility only.

IFR takeoffs for all aircraft are prohibited when the visibility is below the minimum specified in:

- (a) the air operator certificate where the aircraft is operated in accordance with Part VII of the CARs;
- (b) the private operator certificate where the aircraft is operated in accordance with Subpart 604 of the CARs;
- (c) the operations manual of a foreign operator, when accepted by the Minister; or
- (d) for other than the above, the visibility specified in the CAP.

Take-off visibility, in order of precedence, is defined as:

- (a) the reported RVR of the runway to be used (unless it is fluctuating above and below minimum or is less than minimum because of a localized phenomenon);

- (b) the ground visibility of the aerodrome (if the RVR is unavailable, fluctuating above and below minimum or less than minimum because of a localized phenomenon); or

- (c) when neither (a) nor (b) is available, the visibility for the runway as observed by the pilot-in-command.

The ground visibility of an aerodrome is defined as the visibility reported by:

- (a) an ATC unit;
- (b) an FSS;
- (c) a Community Aerodrome Radio Station (CARS);
- (d) a ground-based radio station that is operated by an air operator; or
- (e) an AWOS used for the purpose of making aviation weather observations.

With respect to takeoff visibility, RVR is not governing if below minimum but subject to “fluctuations” or “local phenomenon” effects. If this is the case at the time of takeoff, pilots will be advised of the governing ground visibility by the appropriate ATS unit. In the case of RVR fluctuations, if the reported

minimum fluctuation value is below the required minimum RVR, but the ground visibility is reported at or above minimum, a takeoff may be carried out. Likewise in the case of a local phenomenon reducing RVR below minimum, whether steady or fluctuating, a takeoff may be accomplished if the ground visibility is reported to be at or above the required minimum.

Example:

A takeoff is to be conducted from Runway 27; the pilot is authorized a takeoff minimum of RVR 2600 (1/2 SM).

1. ATC/FSS reports "... RVR Runway 27 is 2000, variable 1600-2800, tower visibility 1/2 mile".

A takeoff is authorized although fluctuations are below minimum because the reported ground visibility of 1/2 mile is governing.

2. ATC/FSS reports "... RVR Runway 27 is 2200, visibility observed on-the-hour 1/4 mile, tower visibility now 1/2 mile".

A takeoff is authorized because the RVR is reduced by a local phenomenon and therefore the reported ground visibility of 1/2 mile is governing. A local phenomenon is deemed to exist if the RVR readout is less than the tower visibility.

3. ATC/FSS reports "... RVR 2600, tower visibility 1/4 mile".

A takeoff is authorized since the lowest RVR reported is at or above minimum and therefore governing.

4. ATC/FSS reports "... RVR Runway 27 is 2000, variable 1600-2800, tower visibility 1/4 mile".

A takeoff is not authorized since the lowest RVR is below minimum and the reported ground visibility of 1/4 mile is governing.

5. ATC/FSS reports "... RVR Runway 27 is 2000 ...".

A takeoff is not authorized.

6. ATC/FSS/CARS reports only "... visibility observed on-the-hour 1/4 mile".

A takeoff is not authorized. 7. RVR and/or visibility not reported;

The pilot-in-command determines available visibility.

In summary, a takeoff is authorized whenever:

- (a) the lowest reported RVR for the runway is at or above the minimum, regardless of reported ground visibility;

- (b) a reported ground visibility for the aerodrome is at or above the minimum, regardless of the reported RVR for the runway; or

- (c) in the absence of a reported RVR or reported ground visibility, pilot-in-command observed visibility is at or above minimum.

9.19.2 Approach Ban

9.19.2.1 General Aviation—Non-Precision Approach (NPA), Approach Procedure with Vertical Guidance (APV), CAT I or CAT II Precision Approach

(Commercial Operators, see RAC 9.19.2.3 Approach Ban—Commercial Operators)

CAR 602.129 specifies that instrument approaches by general aviation aircraft are governed by RVR values only. With certain exceptions, pilots of aircraft are prohibited from completing an instrument approach past the FAF (or where there is no FAF, the point where the final approach course is intercepted) to a runway served by an RVR, if the RVR values as measured for that runway are below the following minima:

MINIMUM RVR		
MEASURED RVR*	AEROPLANES	HELICOPTERS
RVR "A" only	1 200	1 200
RVR "A" and "B"	1 200/600	1 200/0
RVR "B" only	1 200	1 200

* RVR "A" located adjacent to the runway threshold.
RVR "B" located adjacent to the runway mid-point.

The following exceptions to the above prohibitions apply to all aircraft when:

- a. the below-minima RVR report is received, the aircraft is inbound on approach and has passed the FAF, or where there is no FAF, the point where the final approach course is intercepted;
- b. the pilot-in-command has informed the appropriate ATC unit that the aircraft is on a training flight and that the pilot-in-command intends to initiate a missed approach procedure at or above the DH or the MDA, as appropriate;
- c. the RVR is varying between distances less than and greater than the minimum RVR;
- d. the RVR is less than the minimum RVR, and the ground visibility at the aerodrome where the runway is located is reported to be at least one-quarter statute mile; or
- e. the pilot-in-command is conducting a precision approach to CAT III minima.

With respect to approach restrictions, in the case of a localized phenomenon or any fluctuations that affect RVR validity, where the ground visibility is reported by ATC or FSS to be at or above one-quarter statute mile, an approach may be completed.

Example:

An ILS approach is to be conducted to Runway 27; RVR sensors are located at positions A and B; the pilot is flying an aeroplane.

1. ATC/FSS reports "...RVR "A" 800, RVR "B" 800, observed visibility one-quarter statute mile."

An approach to DH/MDA is authorized because the reported ground visibility of one-quarter statute mile is governing.

2. ATC/FSS reports "...RVR "A" not available, RVR "B" 1 000."

An approach to DH/MDA is not authorized since RVR "B" is governing and is below 1 200 ft.

If, after commencing an approach (but before reaching the FAF, or where there is no FAF, the point where the final approach course is intercepted), a pilot must discontinue an approach because the RVR has gone below minima, the pilot shall continue as cleared, advise ATC of their intentions and request further clearance. If further clearance is not received by the time the aircraft reaches the FAF, or where there is no FAF, the point where the final approach course is intercepted, the pilot shall execute a missed approach and proceed via the missed approach procedure to the specified missed approach clearance limit.

In summary, an approach is authorized whenever:

- a. the lowest reported RVR for the runway is at or above minima (CAR 602.129), regardless of reported ground visibility;
- b. the RVR is reported to be varying between distances less than and greater than the minimum RVR;
- c. the RVR is below the minimum, and the ground visibility is reported to be at least one-quarter statute mile;
- d. the RVR for the runway is unavailable or not reported; or
- e. ATS is informed that an aircraft is on a training flight and will conduct a planned missed approach.

No pilot shall commence an NPA, an APV, or a CAT I or CAT II precision approach to an airport where low-visibility procedures are in effect. Low-visibility procedures are associated with CAT III operations. They are specified for an airport (for example, CYVR or CYYZ) in the CAP and restrict aircraft and vehicle operations on the movement area of the airport when the RVR is less than 1 200 ft.

9.19.2.2 Approach Ban—General Aviation—CAT III Precision Approach

(Commercial Operators, see RAC 9.19.2.3 Approach Ban—Commercial Operators)

CAR 602.130 specifies the general aviation CAT III precision approach ban. No pilot shall continue a CAT III precision approach in an IFR aircraft beyond the FAF inbound, or where there is no FAF, the point where the final approach course is intercepted, unless the RVR reported is equal to or greater than the minimum RVR specified in the CAP in respect of the runway or surface of intended approach for the IAP conducted.

MINIMUM RVR—AIRCRAFT—CAT III			
MEASURED RVR*	CAT IIIA	CAT IIIB	CAT IIIC
RVR "A", "B" and "C"	600/600/600	Not Authorized	Not Authorized

*RVR "A" located adjacent to the runway threshold.
 RVR "B" located adjacent to the runway mid-point.
 RVR "C" located adjacent to the runway end.

9.19.2.3 Approach Ban—Commercial Operators—General—Non-Precision Approach (NPA), Approach Procedure with Vertical Guidance (APV), or CAT I Precision Approach

CAR 700.10 specifies the NPA, APV and precision approach ban that generally applies to commercial operators. With certain exceptions, pilots of commercial aircraft are prohibited from completing an NPA, an APV, or a CAT I precision approach past the FAF inbound, or where there is no FAF, the point where the final approach course is intercepted, if the visibility report is below the value corresponding to the CAP advisory visibility for the approach conducted.

MINIMUM VISIBILITY—AEROPLANES—NPA, APV, OR CAT I	
CAP ADVISORY VISIBILITY (SM, RVR x 100 ft)	VISIBILITY REPORT (Grnd Vis SM, RVR "A" or Rwy Vis ft)
1/2 RVR 26	3/8, RVR or Rwy Vis 1 600
3/4 RVR 40	5/8, RVR or Rwy Vis 3 000
1 RVR 50	3/4, RVR or Rwy Vis 4 000
1 1/4	1, RVR or Rwy Vis 5 000
1 1/2	1 1/4, RVR or Rwy Vis 6 000
1 3/4	1 1/2, RVR or Rwy Vis > 6 000
2	1 1/2, RVR or Rwy Vis > 6 000
2 1/4	1 3/4, RVR or Rwy Vis > 6 000
2 1/2	2, RVR or Rwy Vis > 6 000
2 3/4	2 1/4, RVR or Rwy Vis > 6 000
3	2 1/4, RVR or Rwy Vis > 6 000

MINIMUM VISIBILITY	
MEASURED RVR	HELICOPTERS
RVR "A" only	1 200
RVR "A" and "B"	1 200/0
RVR "B" only	1 200

An RVR report takes precedence over a runway visibility report or a ground visibility report, and a runway visibility report takes precedence over a ground visibility report. Ground visibility will only impose an approach ban at aerodromes south of 60°N latitude. If no RVR, runway visibility, or ground visibility is reported, there are no criteria to impose an approach ban. (This concept is similar to the present CAR 602 approach ban, where if there is no RVR reported, there is no criterion to impose an approach ban.)

The following exceptions to the above prohibitions apply to all aircraft when:

- a) the visibility report is below the required value, and the aircraft has passed the FAF inbound, or where there is no FAF, the point where the final approach course is intercepted;
- b) the pilot-in-command has informed the appropriate ATC unit that the aircraft is on a training flight and that the pilot-in-command intends to initiate a missed approach procedure at or above the decision altitude (height) [DA(H)] or the MDA, as appropriate;
- c) the RVR is varying between distances less than and greater than the minimum RVR;
- d) the ground visibility is varying between distances less than and greater than the minimum visibility;
- e) a localized meteorological phenomenon is affecting the ground visibility to the extent that the visibility on the approach to the runway of intended approach and along that runway, as observed by the pilot in flight and reported immediately to ATS, if available, is equal to or greater than the visibility specified in the CAP for the IAP conducted; or
- f) the approach is conducted in accordance with an Operations Specification issued in accordance with CAR 703, 704 or 705.

No pilot shall commence an NPA, an APV, or a CAT I precision approach to an airport where low-visibility procedures are in effect. Low-visibility procedures are associated with CAT III operations. They are specified for an airport (for example, CYVR or CYYZ) in the CAP and restrict aircraft and vehicle operations on the movement area of the airport when the RVR is less than 1 200 ft.

9.19.2.4 Approach Ban—Commercial Operators—CAT II and CAT III Precision Approach

CAR 700.11 specifies the CAT II and CAT III precision approach ban that applies to commercial operators. No pilot shall continue a CAT II or CAT III precision approach in an IFR aircraft beyond the FAF inbound, or where there is no FAF, the point where the final approach course is intercepted, unless the RVR reported is equal to or greater than the minimum RVR specified in the CAP in respect of the runway or surface of intended approach for the IAP conducted.

MINIMUM RVR—CAT II		
MEASURED RVR *	AEROPLANES	HELICOPTERS
RVR "A" only	1 200	1 200
RVR "A" and "B"	1 200/600	1 200/0
RVR "B" only	1 200	1 200

MINIMUM RVR—AIRCRAFT—CAT III			
MEASURED RVR *	CAT IIIA	CAT IIIB	CAT IIIC
RVR "A", "B" and "C"	600/600/600	Not Authorized	Not Authorized

* RVR "A" located adjacent to the runway threshold.
 RVR "B" located adjacent to the runway mid-point.
 RVR "C" located adjacent to the runway end.

9.19.2.5 Approach Ban—Commercial Operators—Operations Specification—Non-Precision Approach (NPA), Approach Procedure with Vertical Guidance (APV), or CAT I Precision Approach

CARs 703.41, 704.37, and 705.48 specify the NPA, APV and precision approach ban that applies to commercial operators through an Operations Specification. CAR 703, 704 and 705 operators authorized through Operations Specification 019, 303 or 503 and who meet all the conditions related to the approach procedure, are permitted to conduct an approach at a visibility value less than those specified in the CAR 700 approach ban. With certain exceptions, pilots of commercial aircraft are prohibited from completing an NPA, an APV, or a CAT I precision approach past the FAF inbound, or where there is no FAF, the point where the final approach course is intercepted, if the visibility report is below the value corresponding to the CAP advisory visibility for the approach conducted.

MINIMUM VISIBILITY—AEROPLANES—703/704/705 OPERATIONS SPECIFICATION—NPA, APV, OR CAT I	
CAP ADVISORY VISIBILITY (SM, RVR x 100 ft)	VISIBILITY REPORT (Grnd Vis SM, RVR "A" or Rwy Vis ft)
1/2 RVR 26	1/4, RVR or Rwy Vis 1 200
3/4 RVR 40	3/8, RVR or Rwy Vis 2 000
1 RVR 50	1/2, RVR or Rwy Vis 2 600
1 1/4	5/8, RVR or Rwy Vis 3 400
1 1/2	3/4, RVR or Rwy Vis 4 000
1 3/4	1, RVR or Rwy Vis 5 000
2	1, RVR or Rwy Vis 5 000
2 1/4	1 1/4, RVR or Rwy Vis 6 000
2 1/2	1 1/4, RVR or Rwy Vis > 6 000
2 3/4	1 1/2, RVR or Rwy Vis > 6 000
3	1 1/2, RVR or Rwy Vis > 6 000

An RVR report takes precedence over a runway visibility report or a ground visibility report, and a runway visibility report takes precedence over a ground visibility report. Ground visibility will only impose an approach ban at

RAC

aerodromes south of 60°N latitude. If no RVR, runway visibility, or ground visibility is reported there are no criteria to impose an approach ban. (This concept is similar to the present CAR 602 approach ban, where if there is no RVR reported, there is no criterion to impose an approach ban.)

The following exceptions to the above prohibitions apply to aeroplanes when:

- a) the visibility report is below the required value and the aircraft has passed the FAF inbound, or where there is no FAF, the point where the final approach course is intercepted; or
- b) the RVR is varying between distances less than and greater than the minimum RVR.

9.19.2.6 Runway Visibility

CAR 602.131 specifies the concept of runway visibility as defined in CAR 101.01(1). The purpose of runway visibility is to determine and report a visibility at the TDZ of a runway that is not equipped with or is not reporting an RVR. An instrument-rated pilot or a qualified person (under CAR 804) can assess runway visibility when RVR sensor detection equipment is not available. In effect, a person is permitted to assess runway visibility from approximately the same position as an RVR “A” sensor installation. CAR Standard 622.131 (for pilots) and CAR Standard 824.25 (for qualified persons) describe how to assess and report runway visibility.

Runway visibility is assessed at or adjacent to the runway threshold, in the direction of the runway, based on runway lights or landmarks that can be seen and recognized. The assessment is made in feet based on a 200-ft runway edge light spacing, or using landmarks found on the applicable CAP aerodrome chart. A report of runway visibility should be reported immediately to ATS in the following format:

“RUNWAY VISIBILITY, RUNWAY [*runway number*] ASSESSED AS [*distance assessed*] FEET AT [*time*] UTC,” to the nearest 100-ft increment.

A runway visibility report is valid for a period of 20 min after it is assessed. If the runway visibility varies during the assessment, the lowest value is reported. The lowest value that is reported is 200 ft, with lower values reported as “... LESS THAN 200 FEET...” The highest value that is reported is 6 000 ft, with higher values reported as “... GREATER THAN 6 000 FEET...”

9.19.2.7 Localized Phenomenon

CAR 700.10 recognizes that certain localized meteorological conditions can reduce the reported ground visibility, thus imposing an approach ban when the flight visibility appears to be much greater. An example would be a localized fog bank that is covering the ground observer’s observation point, resulting in a reported ground visibility of one-quarter statute mile at an aerodrome south of 60°N latitude, while the flight visibility along the approach to the runway and on the runway itself (as observed by the pilot-in-command), is greater than 15 SM. In this case, the pilot can declare a localized phenomenon, and override an approach ban imposed by a ground visibility report. A pilot cannot use localized phenomena to override an RVR or a runway visibility report that imposes an approach ban. To legally continue the approach past the FAF inbound, the flight visibility on the approach path and along the runway must be equal to or greater than the advisory visibility published in the CAP, for the procedure flown, and the pilot-in-command must immediately report the conditions observed to ATS.

CAUTION: Pilots are reminded of the insidious hazard that thin ground-based layers, such as shallow fog, ice fog, or blowing snow can present. Such conditions may allow a pilot-in-command to override an approach ban based on what appears to be a localized phenomenon, when in fact extensive and very poor visibility will be encountered at low altitude during the later stages of the approach, landing and roll-out. The pilot-in-command should take all possible information into account before overriding an approach ban, based on what appears to be a localized phenomenon, in order to avoid conducting an approach during these hazardous conditions.

9.19.3 Landing Minima

CAR 602.128 specifies that landings are governed by published DH/MDAs. Pilots of aircraft on instrument approaches are prohibited from continuing the final approach descent below DH or descending below MDA, as applicable, unless the required visual reference has been established and maintained in order to complete a safe landing. When the required visual reference is not established or maintained, a missed approach must be initiated. Pilots must be cautioned that the missed approach segment that provides for obstacle clearance originates at the published missed approach point (MAP). The published MAP on a precision approach is coincidental with the DH. Missed approaches initiated beyond the MAP will not be assured obstacle clearance.

The visual references required by the pilot to continue the approach to a safe landing should include at least one of the following references for the intended runway, and should be distinctly visible and identifiable to the pilot by:

- (a) the runway or runway markings;
- (b) the runway threshold or threshold markings;
- (c) the touchdown zone or touchdown zone markings;
- (d) the approach lights;

- (e) the approach slope indicator system;
- (f) the runway identification lights;
- (g) the threshold and runway end lights;
- (h) the touchdown zone light;
- (i) the parallel runway edge lights; or
- (j) the runway centreline lights.

Aerodromes that have instrument approaches may not have all of the above items, therefore pilots should consult the appropriate charts and current NOTAM to ascertain the available aids.

Published landing visibilities associated with all instrument approach procedures are advisory only. Their values are indicative of visibilities which, if prevailing at the time of approach, should result in required visual reference being established. (See GEN 5.1 for the definition.) They are not limiting and are intended to be used by pilots only to judge the probability of a successful landing when compared against available visibility reports at the aerodrome to which an instrument approach is being carried out.

9.20 RUNWAY VISUAL RANGE

9.20.1 Definitions

Prevailing Visibility: The maximum visibility value common to sectors comprising one-half or more of the horizontal circle.

NOTE: Prevailing visibility is determined by human observations.

Runway Visual Range (RVR): in respect of a runway, means the maximum horizontal distance, as measured by an automated visual landing distance system and reported by an ATC unit or an FSS for the direction of takeoff or landing, at which the runway, or the lights or markers delineating it, can be seen from a point above its centreline at a height corresponding to the average eye level of pilots at touchdown.

To compute RVR, three factors must be known. The first is the transmissivity of the atmosphere as provided by a visibility sensor. The second is the brightness of the runway lights which is controlled on request by the ATC controller. The third factor is whether it is day or night, since the eye can detect lights easier at night than during the day. There is a period during twilight where there is a problem similar to that with prevailing visibility when neither day, nor night conditions prevail.

RVR is measured by a visibility sensor such as a RVR sensor located near the runway threshold. For CAT II landing systems, a second sensor is provided about the mid-point of the runway. The RVR sensor near the threshold is identified as “A” and the second one as “B”. Their locations are important for the assessment of visibility, and so their positions are indicated on the aerodrome diagrams in CAP.

A light emitted from a source is attenuated in the atmosphere due to snow, fog, rain, and so forth. The amount of this attenuation, or the transmissivity of the atmosphere, can be obtained by measuring the amount of light reaching a detector after being transmitted by a projector. The visibility sensor samples the atmosphere at a height that best represents the slant transmittance from the pilot’s eye at cockpit level to the runway.

9.20.2 Operational Use of RVR

RVR information is available at the ATC IFR arrival control position, the PAR position, the control tower, the FSS and some EC weather stations.

When applicable, RVR information is given to the pilot as a matter of routine and can be used in the determination or application of visibility minima only if the active runway is served by the visibility sensor. RVR information, found in the Remarks section of surface weather reports, is not to be used for operational purposes and is superseded by any RVR information from ATS personnel.

NOTE: RVR reports are intended to provide an indication of how far the pilot can expect to see along the runway in the touchdown zone; however, the actual visibility at other points along the runway may differ due to differing weather conditions. This should be taken into account when decisions must be made based on reported RVR.

A pertinent phenomenon that occurs fairly often during periods of low visibility is large fluctuations that occur over extremely short time intervals. As per ICAO recommendations, the RVR computer automatically averages the readings over the last minute.

The controller will provide the RVR if it is less than 6 000 ft, or upon request. The RVR will be provided in 100-ft increments from 300 ft to 1 199 ft, in 200-ft increments from 1 200 ft to 2 999 ft, and in 500-ft increments from 3 000 ft to 6 000 ft. The RVR remains constant for runway light settings of 1, 2 and 3, but it can increase for settings of 4 and 5. If the latter settings are used, the pilot will be provided with both the RVR and the light setting.

NOTE: At aerodromes equipped with ARCAL, the light settings may not be known to ATS personnel.

In daytime, even a high intensity setting can fade into background brightness. For example, the pilot may be provided with an RVR of 4 000 ft while making an approach when shallow fog is occurring over a snow surface in bright sunlight. Because of the glare, runway lights will be difficult to see; therefore, visibility will be much less than the reported RVR. In situations such as this, the use of prevailing visibility would be more appropriate.

RVR may be used instead of prevailing visibility for landing and take-off minima, but only for runways equipped with an RVR system. In such cases, the following table can be used.

GROUND VISIBILITY	RVR
1 mile	5 000 feet
3/4 mile	4 000 feet
1/2 mile	2 600 feet
1/4 mile	1 400 feet
See Note 2	under 1 200 feet

- NOTES** 1: A comparative scale converting RVR-feet into RVR-metres is shown in GEN 1.9.3.
- 2: Ground visibility does not apply to operators with a takeoff limit below 1 200 feet.

ATS phraseology applicable to the foregoing is as follows:

Runway (number) visual range/ RVR three thousand six hundred feet.

Runway (number) visual range/ RVR less than three hundred feet.

Runway (number) visual range/ RVR more than six thousand feet.

Runway (number) visual range/ RVR (number) feet, fluctuating (number) to (number) feet, visibility (fraction) mile.

Runway (number) visual range/ RVR (number) feet, runway lights at setting four/five.

Runway (number) visual range/ RVR ALFA (number) feet, BRAVO (number) feet, CHARLIE (number) feet.

9.21 AIRCRAFT CATEGORIES

Aircraft performance differences have an effect on the airspace and visibility needed to perform certain manoeuvres. In order that the appropriate obstacle clearance areas, and landing and departure minima can be established, five different aircraft categories have been identified. Aircraft that are manoeuvred within these category speed ranges are to use the appropriate instrument approach minima for that category. For example, an aircraft that is flown on a straight-in approach at 135 kt is to use the Category C approach minima. However, if that same aircraft is required to manoeuvre on a circling approach at 143 kt, then the Category D circling minima applies. The category speed groupings are:

CATEGORY	A	B	C	D	E
SPEEDS	up to 90 kt (includes all rotorcraft)	91 to 120 kt	121 to 140 kt	141 to 165 kt	above 165 kt

NOTE: Category E Minima are not provided for on civil instrument approach procedure charts.

9.22 STRAIGHT-IN LANDING MINIMA

Minima for a straight-in landing are published when a normal rate of descent can be made from the final approach fix (FAF) to the runway threshold and when the final approach track intersects the extended runway centre-line within 30° and within a prescribed distance from the threshold. When either the normal rate of descent or the runway alignment exceeds the criteria, straight-in landing minima are not published and only circling minima apply. The fact that only circling minima are published does not preclude a pilot from landing straight-in if the required visual reference is available in sufficient time to make a normal approach and landing.

NOTE: The term straight-in used in connection with landing should not be confused with its use in straight-in approach minima (RAC 9.16). An ATC clearance for a straight-in approach merely clears the aircraft for an approach without first completing a procedure turn. The minima that will subsequently be used will be based on considerations such as the runway in use, published minima, aircraft category, etc.

The use of straight-in landing minima is predicated upon the pilot having the wind direction and speed and runway condition reports required to conduct a safe landing. At an uncontrolled aerodrome where the pilot may lack the necessary information, the pilot is expected to verify that the runway is unobstructed prior to landing. In some cases, this can only be accomplished by conducting a circling approach using the appropriate circling minima.

At an uncontrolled aerodrome, runway conditions (including any temporary obstructions such as vehicles) may be determined by the pilot by:

- (a) contacting the appropriate FSS or UNICOM at the destination;
- (b) a preflight telephone call to the destination to arrange for making the necessary information available when required for landing;
- (c) a visual inspection;
- (d) a NOTAM issued by the aerodrome operator; or
- (e) any other means available to the pilot, such as message relay from preceding aircraft at the destination.

9.23 CIRCLING

Circling is the term used to describe an IFR procedure that is conducted by visually manoeuvring an aircraft, after completing an instrument approach, into position for landing on a runway which is not suitably located for a straight-in landing (not usually applicable to rotorcraft).

The visual manoeuvring area for a circling approach is determined by drawing arcs centred on each runway threshold, and joining those arcs with tangent lines. The radius (R) of the arcs are related to the aircraft category as follows: A, 1.3 NM; B, 1.5 NM; C, 1.7 NM; D, 2.3 NM; E, 4.5 NM. (Category E circling minima are published at DND aerodromes only.) The circling MDA provides a minimum of 300 feet above all obstacles within the visual manoeuvring area for each category.

Figure 9.3 – Visual Manoeuvring (Circling) Area

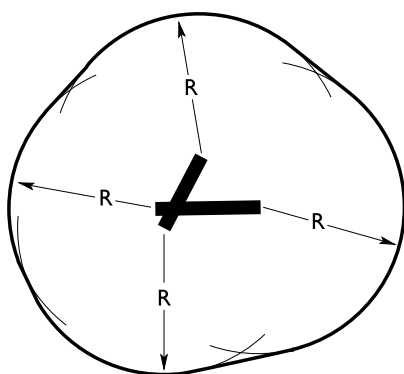

If it is necessary to manoeuvre an aircraft at a speed in excess of the upper limit of the speed range for its approach category, the circling minima for the next higher category should be used in order to ensure appropriate protection from obstacles.

Circling restrictions are published at some locations to prevent circling manoeuvres in certain sectors or directions where higher terrain or prominent obstacles exist. This practice allows the publication of lower minima than would otherwise be possible. In such cases, the circling MDA DOES NOT PROVIDE OBSTACLE CLEARANCE WITHIN THE RESTRICTED SECTOR.

9.24 CIRCLING PROCEDURES

An air traffic controller may specify manoeuvring in a certain direction or area due to traffic considerations; however, the selection of the procedure required to remain within the protected area and to accomplish a safe landing rests with the pilot. There can be no single procedure for conducting a circling approach due to variables such as runway layout, final approach track, wind velocity and weather conditions. The basic requirements are to keep the runway in sight after initial visual contact, and remain at the circling MDA until a normal landing is assured. Examples of various circling approach situations are illustrated in Figure 9.4.

Figure 9.4 – Typical Circling Manoeuvres

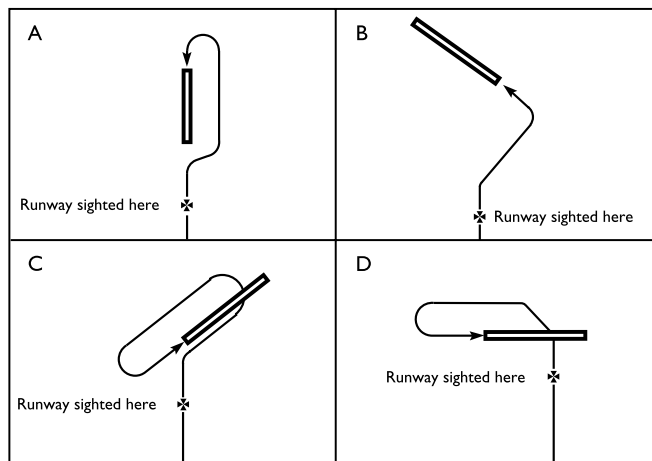

9.25 MISSED APPROACH PROCEDURE WHILE VISUALLY MANOEUVRING IN THE VICINITY OF THE AERODROME

The pilot may have to conduct a missed approach after starting visual manoeuvres. There are no standard procedures in this situation. Thus, unless the pilot is familiar with the terrain, it is recommended that:

- (a) a climb be initiated;
- (b) the aircraft be turned towards the centre of the aerodrome; and
- (c) the aircraft be established, as closely as possible, in the missed approach procedure published for the instrument approach procedure just completed.

With the runway in sight at circling the MDA, the pilot should execute the missed approach if there is any doubt that the ceiling and visibility are inadequate for manoeuvring safely to the point of touchdown.

9.26 MISSED APPROACH PROCEDURES

Whenever a pilot conducts a published missed approach from an instrument approach procedure, the aircraft must continue along the published final approach course to the published Missed Approach Point (MAP) and follow the published missed approach instructions. The pilot may climb immediately to the altitude specified in the missed approach procedure or assigned by ATC. In the event of a missed approach when no missed approach clearance has been received, the pilot will follow the published missed approach instructions. Should the pilot arrive at the missed approach holding fix prior to receiving further clearance, the pilot will:

- (a) hold in a standard holding pattern on the inbound track used to arrive at the fix;

RAC

- (b) if there is a published missed approach track to the fix, hold in a standard holding pattern inbound to the fix on this track;
- (c) if there is a published shuttle or holding pattern at the fix, hold in this pattern regardless of the missed approach track to the fix; or
- (d) if there are published missed approach holding instructions, hold in accordance with these.

If a clearance to another destination has been received, the pilot shall, in the absence of other instructions, carry out the published missed approach instructions until at an altitude which will ensure adequate obstacle clearance before proceeding on course.

If specific missed approach instructions have been received and acknowledged, the pilot is required to comply with the new missed approach instructions before proceeding on course, e.g., “on missed approach, climb runway heading to 3 000 feet; right turn, climb on course” or “on missed approach, climb straight ahead to the BRAVO NDB before proceeding on course”.

Civil and military air traffic control procedures do not require the air traffic controller to provide terrain and obstacle clearance in their missed approach instructions. Terms such as “on missed approach, right turn climb on course” or “on missed approach, left turn on course” are not to be considered specific missed approach instructions. It remains the pilot’s responsibility to ensure terrain and obstacle avoidance and clearance.

9.27 SIMULTANEOUS PRECISION INSTRUMENT APPROACHES – PARALLEL RUNWAYS

When simultaneous precision instrument approaches are in progress, ATC will vector arriving aircraft to one or the other of the parallel localizers for a straight-in final approach. (When cleared for a straight-in approach, a procedure turn is not permitted.) Each of the parallel approaches has a “high side” and a “low side” for vectoring and to allow for vertical separation until each aircraft is established inbound on their respective parallel localizers.

The pilot will be instructed to change and report on the tower frequency prior to reaching the outer marker inbound. If an aircraft is observed to overshoot the localizer during the final turn, the pilot will be instructed to return to the correct localizer course immediately. After an aircraft is established on the localizer, the controller monitoring the final approach will issue control instructions only if an aircraft deviates or is expected to deviate by 1 500 feet from the localizer centreline. Information or instructions issued by the monitoring controller will be aimed at returning the aircraft to the localizer course. If the aircraft fails to take corrective action, the aircraft on the adjacent localizer may be issued appropriate control instructions. Monitoring of the approach is terminated without

notification to the pilot when the aircraft is 1 NM from the runway threshold. If considered necessary, appropriate missed approach instructions will be issued.

THE APPROACH CLEARANCE WILL INCLUDE AN ALTITUDE THAT MUST BE MAINTAINED UNTIL INTERCEPTING THE GLIDE PATH. If the glide path is inoperative, the pilot will be cleared to maintain an altitude to a specified DME distance before commencing the descent.

When informed by ATIS or by the arrival controller that simultaneous precision instrument approaches are in progress, pilots should advise the arrival controller immediately of any avionics unserviceabilities having an impact on their capabilities to accept this procedure.

9.28 SIMULTANEOUS PRECISION INSTRUMENT APPROACHES – CONVERGING RUNWAYS

ATC may clear pilots for precision instrument approaches simultaneously to converging runways at airports where this procedure has been approved.

Aircraft will be informed through ATIS or by the arrival controller as soon as feasible after initial contact when simultaneous precision instrument approaches to converging runways are in progress. When simultaneous approaches are in progress, ATC will vector arriving aircraft to the appropriate runway localizer for a straight-in final approach. Pilots should advise the arrival controller immediately of any malfunctioning or inoperative equipment making this procedure undesirable.

These are the restrictions for simultaneous precision approaches to converging runways:

- Converging runways (defined as an included angle between 15° and 100°).
- Radar available.
- Precision instrument approach systems (ILS/MLS) operating on each runway.
- Non-intersecting final approach courses.
- Missed approach points at least 3 NM apart.
- Non-overlapping primary missed approach protected airspace.
- Separate instrument approach charts denoting the procedures.
- If runways intersect, tower controllers must be able to apply visual separation as well as intersecting runway separation criteria.
- Only straight-in approaches and landing are authorized.

To emphasize the protection of active runways and to aid in preventing runway incursions, landing instructions which include the words “HOLD SHORT” should be acknowledged by a readback of the hold point by the pilot.

10.0 INSTRUMENT FLIGHT RULES – HOLDING PROCEDURES

10.1 GENERAL

Pilots are expected to adhere to the aircraft entry and holding manoeuvres, as described in RAC 10.5, since ATC provides lateral separation in the form of airspace to be protected in relation to the holding procedure.

10.2 HOLDING CLEARANCE

A holding clearance issued by ATC includes at least

- (a) a clearance to the holding fix;
- (b) the direction to hold from the holding fix;
- (c) a specified radial, course, or inbound track;
- (d) if DME is used, the DME distances at which the fix end and outbound end turns are to be commenced [e.g., hold between (number of miles) and (number of miles).];

NOTE: In the absence of an outbound DME being issued by ATC, pilots are expected to time the holding pattern in accordance with RAC 10.6.

- (e) the altitude or FL to be maintained; and
- (f) the time to expect further clearance or an approach clearance; or
- (g) the time to leave the fix in the event of a communications failure.

NOTE: An expect-further-clearance time is usually followed by further en route clearance, which is followed by an expect-approach-clearance time when traffic conditions permit.

During entry and holding, pilots manually flying the aircraft are expected to make all turns to achieve an average bank angle of at least 25° or a rate of turn of 3° per second, whichever requires the lesser bank. Unless the ATC clearance contains instructions to the contrary, or a non-standard holding pattern is published at the holding fix, pilots are expected to make all turns to the right after initial entry into the holding pattern.

Occasionally, a pilot may reach a clearance limit before obtaining further clearance from ATC. In this event, where a holding pattern is published at the clearance limit, the pilot is to hold as published. Where no holding pattern is published, the pilot is to hold in a standard pattern on the inbound track to such clearance limit and request further clearance. (See RAC 10.10 for procedure to be used when the holding pattern is published on en route charts or terminal area charts.)

If communication cannot be established with ATC, the pilot should then proceed in accordance with communication failure procedures as described in RAC 6.3.2.

Examples

1. A westbound flight on R77, cleared to Greely NDB (YRR) reaches Ottawa before obtaining further clearance. The pilot is to hold at YRR on an inbound track of 287° and request further clearance.
2. The published missed approach procedure for an ILS RWY 23 approach at Halifax is the following: *"CLIMB TO 2 200 ON TRACK OF 234° TO "ZHZ" NDB."*

A pilot missing an ILS approach to RWY 23 and not in receipt of further clearance is to proceed directly to the "ZHZ" NDB, make a right turn and hold at the "ZHZ" beacon on an inbound track of 234° and request further clearance.

If for any reason a pilot is unable to conform to these procedures, ATC should be advised as early as possible.

10.3 STANDARD HOLDING PATTERN

A standard holding pattern is depicted in Figure 10.1 in terms of still air conditions.

Figure 10.1 – Standard Holding Pattern

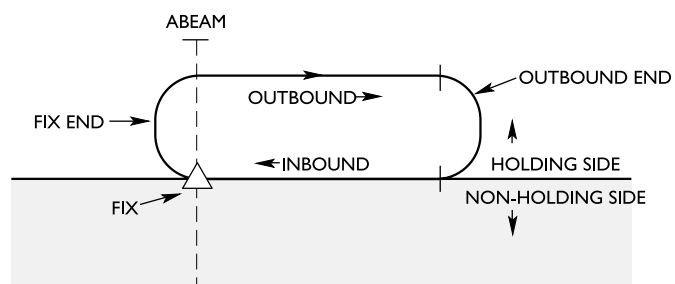

- (a) Having entered the holding pattern, on the second and subsequent arrivals over the fix, the pilot executes a right turn to fly an outbound track that positions the aircraft most appropriately for the turn onto the inbound track. When holding at a VOR, the pilot should begin the turn to the outbound leg at the time of station passage as indicated on the TO-FROM indicator.
- (b) Continue outbound for one minute if at or below 14 000 ft ASL, or one and a half minutes if above 14 000 ft ASL. (ATC specifies distance, not time, where a DME fix is to be used for holding.)
- (c) Turn right to realign the aircraft on the inbound track.

10.4 NON-STANDARD HOLDING PATTERN

A non-standard holding pattern is one in which

- (a) the fix end and outbound end turns are to the left; and/or
- (b) the planned time along the inbound track is other than the standard one-minute or one-and-a-half minute leg appropriate for the altitude flown.

10.5 ENTRY PROCEDURES

The pilot is expected to enter a holding pattern according to the aircraft's heading in relation to the three sectors shown in Figure 10.2, recognizing a zone of flexibility of five degrees on either side of the sector boundaries. For holding on VOR intersections or VOR/DME/TACAN fixes, entries are limited to the radials or DME arcs forming the fix as appropriate.

Figure 10.2—Entry Sectors

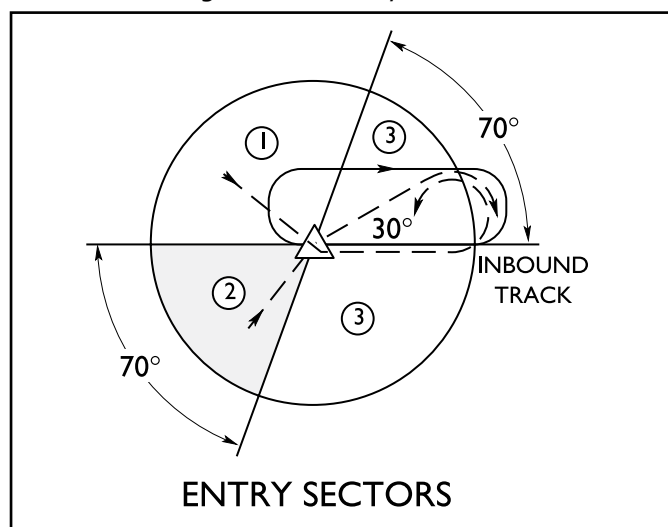

Sector 1 procedures (parallel entry) are:

- (a) Upon reaching the fix, turn onto the outbound heading of the holding pattern for the appropriate period of time.
- (b) Turn left to intercept the inbound track or to return directly to the fix.
- (c) On the second arrival over the fix, turn right and follow the holding pattern.

Sector 2 procedures (offset entry) are:

- (a) Upon reaching the fix, turn to a heading that results in a track having an angle of 30° or less from the inbound track reciprocal on the holding side.
- (b) continue for the appropriate period of time, then turn right to intercept the inbound track and follow the holding pattern.

Sector 3 procedure (direct entry) is:

- (a) Upon reaching the fix, turn right and follow the holding pattern.

Entry procedures to a non-standard pattern requiring left turns are oriented in relation to the 70° line on the holding side (Figure 10.3), just as in the standard pattern.

Figure 10.3 – Left Hand Pattern Entry

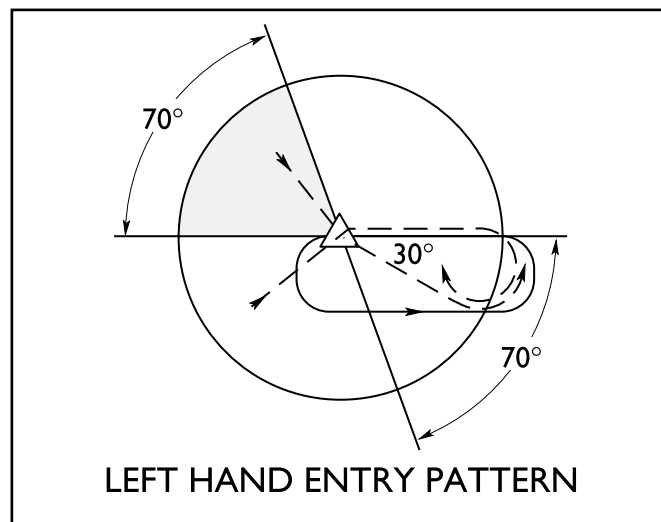

When crossing the fix to enter a holding pattern, the appropriate ATC unit should be advised. ATC may also request that the pilot report “established in the hold”. The pilot is to report “established” when crossing the fix after having completed the entry procedure.

10.6 TIMING

The still air time for flying the outbound leg of a holding pattern should not exceed 1 min if at or below 14 000 ft ASL, or 1 1/2 min if above 14 000 ft ASL; however, the pilot should make due allowance in both heading and timing to compensate for wind effect.

After the initial circuit of the pattern, timing should begin abeam the fix or on attaining the outbound heading, whichever occurs later. The pilot should increase or decrease outbound times, in recognition of winds, to effect 1 or 1 1/2 min (appropriate to altitude) inbound to the fix.

When the pilot receives ATC clearance specifying the time of departure from the holding fix, adjustments should be made to the flight pattern within the limits of the established holding pattern to leave the fix as close as possible to the time specified.

10.7 SPEED LIMITATIONS

Holding patterns must be entered and flown at or below the following airspeeds:

- (a) Propeller Aircraft (including turboprop)
 - (i) MHA to 30 000 ft 175 kt IAS
- (b) civil turbojet
 - (i) MHA to 14 000 ft 230 kt IAS
 - (ii) above 14 000 ft 265 kt IAS
- (c) Military Turbojet
 - (i) all except those aircraft listed below, 265 kt IAS
 - (ii) CF-5 310 kt IAS
 - (iii) CT-114 175 kt IAS
- (d) Climbing while in the holding pattern
 - (i) turboprop aircraft, normal climb airspeed for aircraft type, subject to CAR 602.32
 - (ii) jet aircraft, 310 kt IAS or less, subject to CAR 602.32 (see RAC 10.9)

NOTE: 250 kt IAS must be observed below 10 000 ft ASL and 200 kt IAS below 3 000 ft AGL within 10 NM of a controlled aerodrome even if in climb (see CAR 602.32).

Minimum Holding Altitude (MHA) – The lowest altitude prescribed for a holding pattern which assures navigational signal coverage, communications and meets obstacle clearance requirements.

Pilots are to advise ATC immediately if airspeeds in excess of those specified above become necessary for any reason, including turbulence, or if unable to accomplish any part of the holding procedure. After such higher speed is no longer necessary, the aircraft should be operated at or below the specified airspeeds, and ATC notified.

NOTE: Airspace protection for turbulent air holding is based on a maximum of 280 kt IAS or Mach 0.8, whichever is lower. Considerable impact on the flow of air traffic may result when aircraft hold at speeds which are higher than those specified above.

After departing a holding fix, pilots should resume normal speed subject to other requirements, such as speed limitations in the vicinity of controlled airports, specific ATC requests, etc.

10.8 DME PROCEDURES

DME holding is subject to the same entry and holding procedures previously described except that distances, in NM are used in lieu of time values.

In describing the direction from the fix on which to hold and the limits of a DME holding pattern, an ATC clearance will specify the DME distance from the navigation aid at which the inbound and outbound legs are to be terminated. The end of each leg is determined by the DME indications.

Figure 10.4 –DME Hold

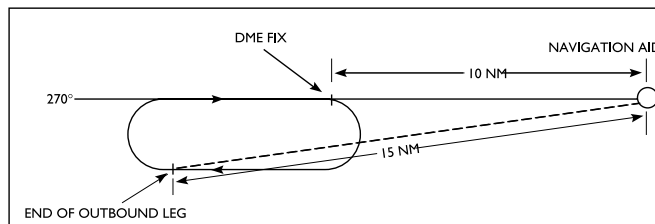

Example:

An aircraft cleared to the 270° RADIAL 10 mile DME FIX, to HOLD BETWEEN 10 AND 15 miles, will hold inbound on the 270° radial, commence turn to the outbound leg when the DME indicates 10 NM and commence turn to inbound leg when the DME indicates 15 NM.

10.9 SHUTTLE PROCEDURE

A shuttle procedure is defined as a manoeuvre involving a descent or climb in a pattern resembling a holding pattern. Shuttles are generally prescribed on instrument procedure charts located in mountainous areas. In the approach phase, it is normally prescribed where a descent of more than 2 000 ft is required during the initial or intermediate approach segments. It can also be required when flying a missed approach or departure procedure from certain airports. A shuttle procedure shall be executed in the pattern as published unless instructions contained in an ATC clearance direct otherwise.

The standard holding airspeeds may not be adequate for climbing, primarily because operational climb airspeeds usually exceed level holding speeds. If no airspeed limit is published on a climb shuttle (e.g. departure or missed approach), then in accordance with CAR 602.32, normal climb airspeeds applicable to aircraft type and airspace classification could be flown (see RAC 10.7(d)). Likewise, if no airspeed limit is published on a descent shuttle (e.g. arrival or approach), then maximum airspeeds appropriate to aircraft type and airspace classification, subject to CAR 602.32, must be observed.

To ensure that the aircraft does not exceed the obstacle clearance protected airspace during a shuttle descent or climb, the aircraft must not exceed:

- (a) the airspeed limit, as published on instrument procedure charts; and/or
- (b) the normal climb or descent airspeed for aircraft type and airspace classification, subject to CAR 602.32 (if no airspeed limit is published); and/or
- (c) the outbound/inbound still air time restrictions (see RAC 10.6); and/or

(d) the DME holding restrictions (see RAC 10.8).

NOTE: 250 kt IAS must be observed below 10 000 ft ASL and 200 kt IAS below 3 000 ft AGL within 10 NM of a controlled aerodrome even if in climb (see CAR 602.32).

10.10 HOLDING PATTERNS PUBLISHED ON EN-ROUTE AND TERMINAL CHARTS

At some high traffic density areas, holding patterns are depicted on IFR terminal area and enroute charts. When pilots are cleared to hold at a fix where a holding pattern is published, or if clearance beyond the fix has not yet been received, pilots are to hold according to the depicted pattern using normal entry procedures as described in RAC 10.5, and timing in the hold as described in RAC 10.6. ATC will use the following phraseology when clearing an aircraft holding at a fix that has a published holding pattern;

CLEARED TO THE (fix), HOLD (direction) AS PUBLISHED EXPECT FURTHER CLEARANCE AT (time)

NOTE: The holding direction means the area in which the hold is to be completed in relation to the holding fix, e.g., east, northwest, etc. If a pattern is required that is different than that published, detailed holding instructions will be issued by ATC.

If a pilot is instructed to depart a fix that has a published hold, at a specified time, the pilot has the option to:

- (a) proceed to the fix, then hold until the “depart fix” time specified;
- (b) reduce speed to make good his “depart fix” time; or
- (c) a combination of (a) and (b).

RAC

11.0 NORTH ATLANTIC OPERATIONS

11.1 REGULATION REFERENCE DOCUMENTS AND GUIDANCE MATERIAL

11.1.1 Regulation

Canadian Aviation Regulation (CAR) 602.38 – Flight Over the High Seas, requires pilots of Canadian aircraft, when flying over the high seas, to comply with the applicable rules of the air set out in ICAO Annex 2, and with the applicable regional supplementary procedures set out in ICAO, Doc 7030/4.

11.1.2 NAT Documents and Guidance Material

(a) The following documents and guidance material are applicable to operations in the NAT Region:

- (i) ICAO, Annex 2—*Rules of the Air*;
- (ii) ICAO, Annex 11 —*Air Traffic Services*;
- (iii) ICAO, Doc 7030 —*Regional Supplementary Procedures (NAT)*;
- (iv) ICAO, Doc 4444 —*Procedures for Air Navigation Services - Air Traffic Management (PANS-ATM)*;
- (v) ICAO, NAT Doc 001—*Guidance and Information Material Concerning Air Navigation in the North Atlantic Region*;
- (vi) *North Atlantic MNPS Airspace Operations Manual*;
- (vii) *North Atlantic International General Aviation Operations Manual*;
- (viii) *Gander Data link Oceanic Clearance Delivery (OCD) Crew Procedures*; and
- (ix) *Guidance Material for ATS Data Link Services in North Atlantic Airspace*.

(b) Those documents listed under RAC 11.1.2(a)(v) to (ix) are available from the North Atlantic Programme Coordination Office Website at <www.paris.icao.int/>.

(c) The *North Atlantic International General Aviation Operations Manual* is available to all operators from:

Regional Manager, General Aviation
 Transport Canada Safety and Security
 P.O. Box 42
 Moncton NB E1C 8K6

Tel.: 506 851-7131

Fax: 506 851-2563

11.2 GENERAL AVIATION AIRCRAFT

CAR 602.39 – *Transoceanic Flight*, specifies the following:

602.39

No pilot-in-command of a single-engined aircraft, or of a multi-engined aircraft that would be unable to maintain flight in the event of the failure of any engine, shall commence a flight that will leave Canadian Domestic Airspace and enter airspace over the high seas unless

- (a) the pilot-in-command holds a pilot licence endorsed with an instrument rating;
- (b) the aircraft is equipped with
 - (i) the equipment referred to in section 605.18,
 - (ii) a high frequency radio capable of transmitting and receiving on a minimum of two appropriate international air-ground general purpose frequencies, and
 - (iii) hypothermia protection for each person on board; and
- (c) the aircraft carries sufficient fuel to meet the requirements of section 602.88 and, in addition, carries contingency fuel equal to at least 10 per cent of the fuel required pursuant to section 602.88 to complete the flight to the aerodrome of destination.

11.3 NORTH AMERICAN ROUTES

- (a) The North American Routes (NAR) System interfaces with the NAT oceanic and domestic airspace, and is used by air traffic transiting the North Atlantic. NARs extend to/from established oceanic coastal fixes to major airports throughout Canada and the United States.
- (b) NAR procedures and routes are published in the *Canada Flight Supplement (CFS)*, Planning Section and in the *Airport Facility Directory – Northeast (FAA)*.

- (c) To permit an orderly change-over between successive OTS, a period of several hours is interposed between the termination of one system and the commencement of the next. During these periods, operators are expected to file random routes or use the co-ordinates of a track in the system about to come into effect.
- (d) Eastbound traffic crossing 30°W at 1030 UTC or later and westbound traffic crossing 30°W at 0000 UTC or later should plan to avoid the OTS.

Figure 11.1 – Gander Oceanic Control Area

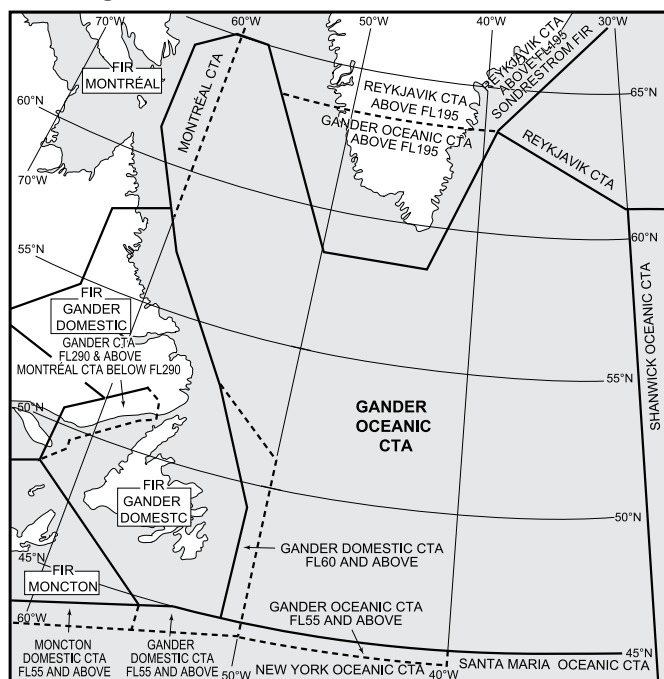

11.4 NAT ORGANIZED TRACK SYSTEM

- (a) Organized tracks are formulated and published in a NAT Track Message via AFTN to all interested operators. The day-time structure is published by Shanwick Area Control Centre (ACC) and the night-time structure by Gander ACC. The hours of validity of the two Organized Track Systems (OTS) are normally:
 - (i) day-time OTS – 1130 – 1900 UTC at 30°W
 - (ii) night-time OTS – 0100 – 0800 UTC at 30°W

The hours of validity are specified in the track message.
- (b) The most northerly track of a day OTS is designated as NAT Track Alpha; the adjacent track to the south, as NAT Track Bravo; etc. For the night OTS, the most southerly track is designated as Track Zulu; the adjacent track to the north, as Track Yankee; etc. Flight levels are allocated for use within the OTS and, in most cases, details of domestic entry and exit routings associated with individual tracks are provided in the NAT Track Message.

11.5 FLIGHT RULES

- (a) Over the high seas, the lower limit of all NAT Oceanic Control Areas (OCA) is FL55 with no upper limit. Throughout the NAT Region, airspace at and above FL55 is Class A controlled airspace, and below FL55 is Class G uncontrolled airspace.
- (b) Flights shall be conducted in accordance with the instrument flight rules (even when not operating in instrument meteorological conditions (IMC) when operated at or above FL60.
- (c) Air traffic control (ATC) clearances to climb or descend maintaining one's own separation while operating in visual meteorological conditions (VMC) shall not be issued.

11.6 FLIGHT PLANNING PROCEDURES

11.6.1 Routes

- (a) Flights conducted wholly or partially outside the OTS shall be planned along great circle tracks joining successive significant points.
- (b) For flights operating predominately in an east–west direction:
 - (i) south of 70°N, the planned tracks shall be defined by significant points formed by the intersection of half or whole degrees of latitude at each 10° of longitude (60°W, 50°W, 40°W). For flights operating north of 70°N, significant points are defined by the parallels of latitude expressed in degrees and minutes with longitudes at 20° intervals;
 - (ii) the distance between significant points shall, as far as possible, not exceed one hour of flight time. Additional significant points should be established when required because of aircraft speed or the angle at which meridians are crossed. When the flight time between successive significant points is less than 30 min one of the points may be omitted.
- (c) For flights operating predominately in a north–south direction, the planned tracks shall be defined by significant points formed by the intersection of whole degrees of longitude with parallels of latitude spaced at 5° (65°N, 60°N, 55°N).

RAC

- (d) For flights planning to operate within the OTS from the entry point into oceanic airspace to the exit point as detailed in the daily NAT track message, the track shall be defined in Item 15 of the flight plan by the abbreviation “NAT” followed by the Code letter assigned to the track.
- (e) For eastbound NAT flights planning to operate on the OTS, the second and third route options should be indicated at the end of Item 18 of the flight plan. Those operators who do not have the capability to provide this information in Item 18 of the flight plan should send the information by separate AFTN message to Gander ACC (CYQXZQZX).

Examples

1. RMKS/ ... O2.X370 O3.V350 (Option 2 is Track X at FL370; Option 3 is Track V at FL350)
2. RMKS/ ... O2.RS390 O3.Z370 (Option 2 is random track south at FL390; Option 3 is Track Z at FL370)

NOTE: In the preceding examples, Options 2 and 3 are indicated by the letter “O” and not the number zero.

- (f) ATS requires flights entering or exiting the Gander OCA to flight plan in accordance with the published North Atlantic organized track system (NAT OTS) or, if entering or exiting by way of 53°N 050°W and south thereof, via the following oceanic entry points (OEP) and associated 50° west coordinates:

OEP	Coordinates	OEP	Coordinates
HECKK	53°N 050°W	NOVEP	48°N 050°W
CRONO	52°N 050°W	RONPO	47°N 050°W
DENDU	51°N 050°W	URTAK	46°N 050°W
KOBEV	50°N 050°W	VODOR	45°N 050°W
LOGSU	49°N 050°W		

These oceanic entry points are compulsory reporting points for westbound flights only. Eastbound flights are not required to provide a position report unless requested by ATC.

ATS requires flights entering or exiting the New York OCA through CDA to flight plan over NOVOK, JEBBY, BOBTU or TALGO, or via ELERI or MUSPO if arriving at or departing from Halifax Airport (CYHZ). Eastbound flights that exit the New York OCA via CDA and subsequently enter the Gander OCA are required to flight plan in accordance with the published NAT OTS or over an oceanic entry point and associated 50° west coordinate, as provided in the table above.

Flights exiting the New York OCA via BOBTU should contact Gander ACC five minutes prior to BOBTU on frequency 134.7 MHz. Operators should be aware that if the NAT OTS includes tracks that are at or south of BANCS URTAK 46°N 050°W (or 46°N 050°W URTAK BANCS), then optimal flight levels and routes may not be available.

To facilitate effective coordination for flights entering or exiting the Gander domestic CTA and the New York OCA via 44°N 050°W or south thereof:

- Eastbound flights exiting the Gander domestic CTA directly into the New York OCA are required to flight plan via LOMPI direct JAROM direct TALGO, direct 44°N 050°W, or south thereof.
- Eastbound flights exiting the New York OCA directly into the Gander domestic CTA are required to flight plan via BOBTU.
- Westbound flights exiting the New York OCA directly into the Gander domestic CTA are required to flight plan via BOBTU direct JAROM direct LOMPI.

NOTE: TALGO is not to be used for westbound flights.

- (g) Pilots of potential non-stop westbound flights may submit a flight plan to any suitable aeronautical radio facility or designated intersection east of 70°W. The route and altitude to any of the approved regular or alternate aerodromes may be specified. Prior to reaching the flight planned fix or clearance limit, the pilot, after assessing the onward flight conditions, will advise ATC of the intended destination and request an ATC clearance accordingly. If flight to the airport of destination is undesirable, the pilot will request an appropriate ATC clearance to the alternate airport. If an onward ATC clearance from the fix designated in the flight plan is not obtained by the time the fix is reached, the pilot must proceed towards the alternate airport in accordance with the flight plan and amendments thereto.
- h) ATS system parameters require all westbound flights transiting from the Gander OCA to the Montréal FIR/CTA to flight plan via 60°W, followed by both a boundary reporting point and then one of the following inland reporting points: LAKES, LOPVI, RODBO, JELCO, FEDDY, TEFFO, DUTUM, or BEZED. KENKI and IRBIM are not to be used as boundary reporting points.

11.6.2 Airspeed

True airspeed (TAS) or Mach number is to be entered in Item 15 of the flight plan.

11.6.3 Altitude

- (a) The planned cruising level(s) for the oceanic portion of the flight to be included in Item 15 of the flight plan.

NOTE: Flights planning to operate wholly or partly outside the OTS should indicate in a flight plan the cruising level(s) appropriate to direction of flight except that, within the Gander/Shanwick OCAs and the Reykjavik CTA, during the westbound OTS (valid from 1130 to 1900 UTC at 30°W) westbound aircraft may flight plan FL310 or FL330 and during the

eastbound OTS (valid from 0100 to 0800 UTC at 30°W) eastbound aircraft may file a flight plan at FL360 or FL380.

- (b) For flight level allocations applicable to reduced vertical separation minimum (RVSM) refer to subparagraph RAC 11.21.3.
- (c) Requests for a suitable alternative flight level may be indicated in Item 18 of the flight plan.

11.6.4 Estimated Times

- (a) For flights operating on the OTS, the accumulated elapsed time only to the first oceanic flight information region (FIR) boundary are to be entered in Item 18 of the flight plan.
- (b) For flights operating wholly or partly on the OTS, accumulated estimated times to significant points en route (EST) are to be entered in Item 18 of the flight plan.

11.6.5 Aircraft Approval Status and Registration

- (a) For flights certified as being in compliance with minimum navigation performance specifications (MNPS) and intending to operate wholly or partly in MNPS airspace, the approval status (MNPS) shall be indicated in Item 10 by entering the letter “X”. It is the pilots’ responsibility to ensure that specific approval has been given for MNPS operations.
- (b) For flights certified as being in compliance with Reduced Vertical Separation Minimum (RVSM) Minimum Aircraft System Performance Specification (MASPS) and intending to operate wholly or partly at RVSM designated altitudes, the approval status (RVSM) shall be indicated in Item 10 by entering the letter “W”. It is the pilots’ responsibility to ensure that specific approval has been given for RVSM operations.
- (c) For those aircraft being in compliance with both MNPS and RVSM, the letters “X” and “W” shall be entered in Item 10.
- (d) If the aircraft registration is not included in Item 7, the registration shall be indicated in Item 18.

11.6.6 Height Monitoring Unit (HMU)

Aircraft for HMU monitoring shall include in Item 18 of the flight plan the aircraft registration (if not included in Item 7) and the remarks “RMK/HMU FLT STU.

11.6.7 Filing

- (a) NAT operators are to forward all flight plans for eastbound NAT flights to those Canadian ACCs in which the flight will traverse their FIR/CTAs. These flight plans are to include the Estimated Enroute Time (EET) for each CTA boundary in Item 18 of the flight plan. The AFTN address for Canadian ACCs are:

AFTN Address	Canadian ACCs	AFTN Address	Canadian ACCs
CZQXZQZX	Gander	CZWGZQZX	Winnipeg
CZQMZQZX	Moncton	CZEGZQZX	Edmonton
CZULZQZX	Montréal	CZVRZQZX	Vancouver
CZYZZQZX	Toronto		

- (b) Flight plans for flights departing from points within adjacent regions and entering the NAT Region without intermediate stops should be submitted at least 3 hours prior to departure.
- (c) Where possible, operators are to file eastbound NAT flight plans at least 4 hours prior to the ETA at the coast-out fix specified in the flight plan.

11.7 PREFERRED ROUTES MESSAGES

- (a) NAT operators are to send Preferred Routes Messages (PRM) for eastbound and westbound flights to the following:
 - EGGXZQZX (Shanwick ACC)
 - EGTZDZE (London Flow Management Unit)
 - KCFCZDZX (FAA Air Traffic Control System Command Centre)
 - KZNYZRZX (New York ARTCC)
 - BIRDZQZX (Reykjavik ACC)
 - LPPOZQZX (Santa Maria ACC)
 - CZQXZQZX (Gander ACC)
 - CZQMZQZX (Moncton ACC)
 - CZULZQZX (Montréal ACC)
 - CYHQZDZX (Canadian Air Traffic Management Unit)
- (b) The following format is to be used for westbound PRMs:

```
[PRIORITY] [DEST ADDRESS] [DEST ADDRESS] ---
[DATE TIME OF ORIGIN] [ORIGIN ADDRESS]
[MESSAGE TYPE]-[COMPANY]-[WB]-[YYMMDD AT 30W]-
[(DEP/DEST)(FIRST UK POINT)(ANCHOR POINT) (OCA RPS)
(LANDFALL)(INLAND FIX)(NUMBER OF FLT 01-99)]
```

NOTE: If there is no Inland Navigation Fix (INF), the latitude crossing 80°W is to be used.

Example:

```
FF EGGXZQZX EGTZDZE CZQXZQZX CZQMZQZX CZULZQZX
CYHQZDZX KCFCZDZX KZNYZRZX BIRDZQZX LPPOZQZX
11824 LSZHSWRW PRM-SWR-W-930212-LSZH/KJFK BNE BEL
55/10 56/20 57/30 55/40 53/50 YAY TOPPS 02 LSZH/KIAD BNE
BURAK 53/15 53/20 52/30 51/40 50/50 YQX TUSKY 01
```



- (c) The following format is to be used for eastbound PRMs:
[PRIORITY] [DEST ADDRESS] [DEST ADDRESS] -----
[DATE TIME OF ORIGIN] [ORIGIN ADDRESS]
[MESSAGE TYPE]-[COMPANY]-[EB]-[YYMMDD AT 30W]-
[(DEP/DEST)(INLAND FIX)(ANCHOR POINT)(OCA RPS)
(LANDFALL)(LAST UK POINT)(NUMBER OF FLT 01-99)]

NOTE: If there is no INF, the latitude crossing 80°W is to be used.

Example:

```
FF EGGXZOXZ EGTZDZE CZQXZOXZ CZQMZOXZ CZULZOXZ
CYHQZDZX KCFCZDZX KZNYZRZX BIRDZOXZ LPPOZOXZ 120936
EHAMKLMW PRM-KLM-E-930213-KJFK/EHAM TOPPS YAY
53/50 53/40 54/30 54/20 54/15 BABAN BLUFA 03 CYMX/EHAM
YML FOXXE 57/50 58/40 58/30 57/20 56/10 MAC BLUFA 01
```

- (d) PRMs are to be sent for:
- (i) eastbound flights: no later than 1000 UTC, and
 - (ii) westbound flights: no later than 1900 UTC.

11.8 CLEARANCES

11.8.1 Oceanic Clearances

Pilots intending to operate in the Gander OCA should note the following:

- (a) Clearances for VFR climb or descent will not be granted.
- (b) The Mach number to be maintained will be specified for turbojet aircraft.
- (c) ATC will specify the full route details for aircraft cleared on a route other than an organized track or flight plan route. The pilot is to read back the full details of the clearance, including the cleared track.
- (d) ATC will issue an abbreviated oceanic clearance to aircraft that will operate along one of the NAT organized tracks. The abbreviated clearance will include the track letter, the flight level and the Mach number to be maintained (for turbojet aircraft). The pilot is to read back the clearance including the TMI number. ATC will confirm the accuracy of the readback and the TMI number.

NOTE: The eastbound OTS is identified by a TMI number, which is determined by using the Julian calendar for the day on which the eastbound tracks are effective. The TMI number is contained in the “Remarks” section on the eastbound NAT track message.

Amendments to already published tracks are indicated by appending a letter to the Julian date, e.g. TMI 320A. A revised TMI will be issued for changes to:

- any track coordinate(s), including named points;
- published track levels; or
- named points within European routes west.

A TMI revision will not be issued for changes to other items such as NARs.

- (e) Whether received via data link or voice, the oceanic clearance to enter the Gander OCA has the following meaning:

- The clearance is valid only within oceanic airspace, and details the route, altitude and speed at which the flight is to enter oceanic airspace;
- The flight crew is not immediately authorized to change the route, altitude or speed in order to comply with the oceanic clearance;
- The flight crew is required to obtain a subsequent clearance in order to comply with the oceanic clearance; and
- If unable to obtain a subsequent clearance, the flight crew should revert to the procedures for radio communications failure detailed in section RAC 11.20 of the TC AIM, the CFS and the North Atlantic section of ICAO’s *Regional Supplementary Procedures* (Doc 7030) in order to manoeuvre as necessary to comply with the oceanic clearance.

- (f) If the aircraft is designated to report meteorological information, the pilot will be advised by the inclusion of the phrase “SEND MET REPORTS” in the clearance.

- (g) Aircraft routed through the Shanwick, Gander, and New York OCAs that will proceed south of 39°N/067°W do not receive an oceanic clearance to landfall (LF). Shanwick will clear such flights to the first named fix in the New York OCA that is contained in the aircraft’s filed flight plan, followed by the phraseology “VIA FLIGHT PLANNED ROUTE TO DESTINATION.” The phraseology “VIA FLIGHT PLANNED ROUTE” is used once the flight is established in the Shanwick OCA.

The point to where an aircraft is cleared by Shanwick ACC within New York oceanic airspace, prior to the statement “flight planned route to destination,” should not be misinterpreted as a “clearance limit.” Aircraft are expected to continue on course.

It is imperative that operators file flight plans (FPL) and flight plan change (CHG) messages through the New York Oceanic CTA/FIR using the address KZWYZOZX. It must be noted that the oceanic address is separate from the New York domestic address (KZNYZRZX).

11.8.2 Domestic Clearances – NAT Westbound Traffic

- (a) Pilots proceeding westbound across the NAT and entering CDA within the Gander, Moncton and Montréal FIRs should comply with the following procedures:
 - (i) Flights that have been cleared by ATC via the flight planned route prior to reaching CDA will not be issued en-route clearances upon entering domestic airspace, and are to follow the flight planned route as cleared. Domestic en-route clearances will be issued:
 - (A) for flights that have been rerouted and exit oceanic airspace at other than the flight planned exit fix;
 - (B) at a pilot's request for another routing; or
 - (C) if a flight plan has not been received by the ACC.
 - (ii) Flights that have been rerouted from the flight planned route and enter CDA within 120 NM of the flight planned oceanic exit point can anticipate a clearance to regain the flight planned route by the INF unless the pilot requests a different routing. For flights beyond 120 NM from the flight planned oceanic exit point, a clearance will be issued following consultation with the pilot.
 - (iii) ATC will use the latest flight plan received before a flight departs. Subsequent changes to the flight plan route after departure, including any changes received by the pilot from flight operations/dispatch, must be requested directly by the pilot on initial contact with the appropriate domestic ACC. Direct requests from flight operations/dispatch to ATC to re-clear aircraft will only be considered under exceptional circumstances, and are not an acceptable alternative to a pilot-initiated request for a re-clearance.
 - (iv) Domestic re-clearances by ATC may contain either the route specified in full detail or a NAR.
- (b) If entering CDA within the Edmonton FIR, the onward domestic routing will have been established in co-ordination between the Reykjavik and Edmonton ACCs, and additional domestic clearance is not required. If there has been a change in route from the filed flight plan, clarification of the onward routing may be obtained from Edmonton ACC on request.
- (c) Westbound turbojet aircraft that have proceeded across the NAT and have entered CDA shall maintain the last Mach number assigned by ATC:
 - (i) unless approval is obtained from ATC to make a change; or
 - (ii) until the pilot receives an initial descent clearance approaching destination.

11.8.3 Oceanic Clearance Delivery

- (a) Unless otherwise advised by ATC, the following oceanic clearance delivery procedures are in effect daily between 2330 and 0730 UTC (DST 2230 and 0630 UTC) for all

eastbound oceanic flights (including data link equipped aircraft) operating above FL280 that transit the Gander Domestic FIR/CTA:

- (i) Clearance delivery frequencies are published daily in the "Remarks" section on the eastbound NAT track message. Pilots are to contact Gander clearance delivery on the frequency for the track/route as per the NAT track message to which the aircraft is proceeding. Contact with clearance delivery should be made when within 200 NM of the specified clearance delivery frequency location. In the event that contact cannot be established, pilots are to advise ATC on the assigned control frequency.

The following frequencies and frequency locations will normally be used:

- Natashquan (YNA) (50°11'N 61°47'W) – 135.45 MHz;
- Allen's Island (46°50'N 55°47'W) – 128.45 MHz;
- Churchill Falls (UM) (53°35'N 64°14'W) – 128.7 MHz;
- Stephenville (YJT) (48°34'N 58°40'W) – 135.05 MHz;
- Sydney (YQY) (46°09'N 60°03'W) – 119.42 MHz.
- Brevoort (63°20'N 64°08'W) – 132.025 MHz;
- Kuujjuaq (YVP) (58°05'N 68°25'W) – 134.2 MHz.

- (ii) For those operators who do not receive the NAT track message, pilots are to contact Gander clearance delivery on one of the frequencies listed in RAC 11.8.3(a)(i) when within 200 NM of the frequency location. In the event that contact cannot be established, pilots are to advise ATC on the assigned control frequency.
- (b) Pilots are to maintain a continuous listening watch on the assigned control frequency while obtaining the oceanic clearance.
- (c) Unless the flight has received the message "CLA RECEIVED CLEARANCE CONFIRMED END OF MESSAGE," data link oceanic clearances must be verified with Gander clearance delivery during the times indicated above. Outside the indicated hours, oceanic clearances are to be verified on the appropriate control frequency.
- (d) ATC will not normally advise pilots to contact Gander clearance delivery. There is no requirement for pilots to confirm receipt of an oceanic clearance (including a data link oceanic clearance) from Gander clearance delivery with the assigned control frequency.
- (e) Due to frequency congestion on both the clearance delivery and control frequencies, pilots should refrain from unnecessary lengthy discussions with respect to oceanic clearances and procedures. Constructive comments and complaints should be processed post-flight through the company operations.
- (f) Procedures and further information for flights intending to receive oceanic clearances via data link are published in Gander Datalink Oceanic Clearance Delivery (OCD) Crew Procedures.

RAC

11.9 POSITION REPORTS

11.9.1 Requirements

- (a) Unless otherwise requested by ATC, flights shall make position reports at the significant points listed in the flight plan.
- (b) The contents of a position report at geographical coordinates are to be expressed as follows:
 - (i) for generally eastbound or westbound aircraft, latitude shall be expressed in degrees and minutes, longitude in degrees only; and
 - (ii) for generally northbound or southbound aircraft, latitude shall be expressed in degrees only, longitude in degrees and minutes.
- (c) Position reports shall include the reported position, the next reporting point and estimated time, and the succeeding reporting point as per the cleared route. If the estimated time over the next reporting point is found to be in error by three minutes or more, a revised estimated time shall be transmitted as soon as possible to the appropriate ATC unit.
- (d) Position information shall be based on the best obtainable navigation fix. The time of fixing aircraft position shall be arranged so as to provide the most accurate position information and estimates possible.
- (e) When making position reports, all times shall be expressed in UTC, giving both the hour and minutes.

11.9.2 Communications

- (a) All flights operating in the Gander OCA should report on international air-to-ground frequencies.
- (b) In addition to maintaining a listening watch on the appropriate en-route frequency, flights are to establish and maintain communication with Gander, Moncton, or Montréal as soon as possible in accordance with the following:
 - (i) At FL290 or above:
 - (A) 132.05, 230.3, 134.7 or 245.0 MHz for coastal fixes BOBTU to YYT when within 200 NM of YYT.
 - (B) 133.9, 294.5, 125.9, 132.6 or 342.9 MHz for coastal fixes VIXUN to CYMON when within 200 NM of YQX.
 - (C) 134.3 or 128.6 MHz for coastal fixes DOTTY to CARPE when within 200 NM of YAY.
 - (D) 133.42 or 132.4 MHz for coastal fixes OYSTR and SCROD when within 200 NM of YYR.
 - (E) 128.32 MHz for coastal fixes LOACH to MOATT when within 200 NM of HO.
 - (F) 134.0 MHz when within 200 NM of YWK; 126.32 MHz when within 200 NM of YZV; 132.8 MHz when within 200 NM of YGR; 132.75, 133.7, 133.3 or 125.25 MHz when within 200 NM of YQY.

- (ii) At FL280 or below:
 - (A) 133.15 or 227.3 MHz for coastal fixes BOBTU to VIXUN when within 150 NM of YYT.
 - (B) 132.1 or 289.4 MHz for coastal fixes YQX and CYMON when within 150 NM of YQX
 - (C) 133.0 or 371.9 MHz for coastal fixes DOTTY to CARPE when within 150 NM of YAY.
 - (D) 120.4 or 294.5 MHz for coastal fixes OYSTR and SCROD when within 150 NM of YYR.
 - (E) 135.4 MHz for coastal fixes LOACH to MOATT when within 150 NM of HO
 - (F) 134.9 MHz when within 150 NM of Allen's Island (46°50'N 55°47'W); 132.3 or 247.0 when within 150 NM of YJT;
- (c) Eastbound flights that traverse the Gander domestic FIR are required to establish contact with "Gander clearance delivery" in accordance with RAC 11.8.3.
- (d) If an aircraft in the Gander OCA is unable to communicate with Gander Oceanic, pilots are to endeavour to pass position reports by relay through:
 - (i) another oceanic centre with which communication has been established,
 - (ii) another aircraft. In the NAT Region, when out of range of VHF ground stations, 123.45 MHz may be used for air-to-air communications, including the relaying of position reports; or
 - (iii) another aircraft on frequency 121.5 or 243.0 MHz, if no other means is available.

11.10 MINIMUM NAVIGATION PERFORMANCE SPECIFICATIONS (MNPS)

- (a) All operators are to ensure that aircraft used to conduct flights within NAT MNPSA have the minimum navigation equipment. For detailed requirements, refer to the following documents:
 - (i) ICAO, Doc 7030—*Regional Supplementary Procedures (NAT)*;
 - (ii) ICAO, NAT Doc 001—*Guidance and Information Material Concerning Air Navigation in the North (NAT Region)*;
 - (iii) *North Atlantic MNPS Airspace Operations Manual*; and
 - (iv) Parts VI and VII of the *Canadian Aviation Regulations*.
- (b) Eastbound aircraft requesting an oceanic clearance from Gander ACC to enter MNPSA may be requested by ATC to confirm that they are approved for MNPS operations. Pilots/operators unable to provide such confirmation will be issued an oceanic clearance to operate outside MNPSA (below FL285 or above FL420).

11.11 REDUCED VERTICAL SEPARATION MINIMUM (RVSM)—MINIMUM AIRCRAFT SYSTEM PERFORMANCE SPECIFICATIONS (MASPS)

- (a) All operators are to ensure that aircraft used to conduct flights within NAT MNPSA where RVSM is applied meet the MASPS. For detailed requirements, refer to the following publications:
- ICAO, Doc 7030—*Regional Supplementary Procedures (NAT)*;
 - ICAO, NAT Doc 001—*Guidance and Information Material Concerning Air Navigation in the North (NAT Region)*;
 - North Atlantic MNPS Airspace Operations Manual*; and
 - Parts VI and VII of the *Canadian Aviation Regulations*.
- (b) Eastbound aircraft requesting an oceanic clearance from Gander ACC to enter MNPSA at designated RVSM altitudes may be requested by ATC to confirm that they are approved for MNPS and/or RVSM operations. Pilots/operators unable to provide such confirmation will be issued an oceanic clearance to operate outside MNPSA (below FL285 or above FL420) and/or outside the RVSM designated altitudes, as applicable.

11.12 ADHERENCE TO MACH NUMBER

- (a) Turbojet aircraft, in oceanic airspace and Canadian Domestic Airspace, shall adhere to the Mach number assigned by ATC unless approval is obtained from ATC to make a change or until the pilot receives an initial descent clearance approaching destination. If it is essential to make an immediate temporary change in Mach number (e.g., as a result of turbulence), ATC shall be notified as soon as possible that such a change has been made.
- (b) If it is not possible, because of aircraft performance, to maintain the last assigned Mach number during en route climbs and descents, pilots shall advise ATC at the time of the climb/descent request.

11.13 OPERATION OF TRANSPONDERS

The pilot should operate the transponder at all times on Mode A and C, Code 2000, during flight in the NAT Region. However, the last ATC assigned Code must be retained for a period of 30 min after entry into NAT airspace unless otherwise directed by ATC.

NOTE: This procedure does not affect the use of the special-purpose codes 7500, 7600 and 7700.

11.14 METEOROLOGICAL REPORTS

On a routine basis, aircraft must make, record and report meteorological observations at each designated reporting point. However, aircraft cleared on an organized track should be required to make, record and report meteorological observations only upon a specific request by ATC. Such requests will be included in the oceanic clearance using the phrase “SEND MET REPORTS.” ICAO AIREP form Model AR, as contained in Doc 4444, Air Traffic Management, Appendix 1, should be used for this purpose.

11.15 ADHERENCE TO ROUTE

If an aircraft has inadvertently deviated from the route specified in its ATC clearance, it should take immediate action to regain the route within 100 NM from the position at which the deviation was observed.

11.16 STEP-CLIMB PROCEDURE

To facilitate the use of step-climbs, pilots should, on initial contact with ATC at each OCA boundary, include at the end of the position report the highest acceptable level and the time or position at which this level could be accepted.

Example:

POSITION AAL101, 51N 30W 0346 FL330 ESTIMATING 50N 40W 0440 NEXT 50N 50W WILL ACCEPT FL350 AT 40W.

11.17 CRUISE CLIMBS AND ALTITUDE REPORTS

- (a) Aircraft cleared for cruise climbs should report their level to the nearest 100 ft.
- (b) For all altitude changes, either climbs or descents, pilots should report “reaching” the new level/cruising altitude to ATC.

11.18 IN-FLIGHT CONTINGENCIES

- (a) All pilots transiting the North Atlantic should be thoroughly familiar with the in-flight contingency procedures for situations of rapid descent, turnback, diversion and reduction of navigation capability.
- (b) In-flight contingency procedures are published in the following documents:
- ICAO, Doc 7030—*Regional Supplementary Procedures (NAT)*;
 - ICAO, NAT Doc 001—*Guidance and Information Material Concerning Air Navigation in the North Atlantic Region*;
 - North Atlantic MNPS Airspace Operations Manual*; and
 - ICAO, Doc 4444—*Procedures for Air Navigation Services—Air Traffic Management (PANS-ATM)*

11.19 COMMUNICATIONS FAILURE—NAT TRAFFIC

The following procedures are intended to provide general guidance for NAT aircraft experiencing a communications failure. These procedures are intended to complement and not supersede State procedures and regulations as contained in RAC 6.3.2. It is not possible to provide guidance for all situations associated with a communications failure.

11.19.1 General

- (a) If the aircraft is so equipped, a pilot experiencing a two-way radio communications failure shall operate the transponder on Code 7600 and Mode C.
- (b) The pilot shall attempt to contact any ATC facility, inform them of the difficulty, and request that information be relayed to the ATC facility with which communications are intended.

11.19.2 Communications Failure Prior to Entering NAT Oceanic Airspace

- (a) If operating with a received and acknowledged oceanic clearance, the pilot should enter oceanic airspace at the cleared oceanic entry point, flight level and speed, and proceed in accordance with the received and acknowledged oceanic clearance. Any flight level or speed changes required to comply with the oceanic clearance should be completed within the vicinity of the oceanic entry point. The “cleared oceanic flight level” is the flight level contained in the oceanic clearance.
- (b) If operating without a received and acknowledged oceanic clearance, the pilot should enter oceanic airspace at the first oceanic entry point, flight level and speed, as contained in the filed flight plan, and proceed via the filed flight plan route to landfall. The first oceanic flight level and speed should be maintained to landfall.

11.19.3 Communications Failure Prior to Exiting NAT Oceanic Airspace

- (a) If cleared on the flight plan route, the pilot should proceed in accordance with the last received and acknowledged oceanic clearance, including flight level and speed, to the last specified oceanic route point, normally landfall; continue on the flight plan route; maintain the last assigned oceanic flight level and speed to landfall; and, after passing the last specified oceanic route point, conform with the relevant State procedures and regulations.
- (b) If cleared on other than the flight plan route, the pilot should proceed in accordance with the last received and acknowledged oceanic clearance, including flight level and speed, to the last specified oceanic route point, normally landfall. After passing this point, the pilot should conform with the relevant State procedures and regulations, rejoining the filed flight plan route by proceeding, via published ATS

routes where possible, to the next significant point ahead as contained in the filed flight plan.

Figure 11.2 – North Atlantic Minimum Navigation Performance Specification Airspace (NAT MNPSA) Between FL285 and FL420

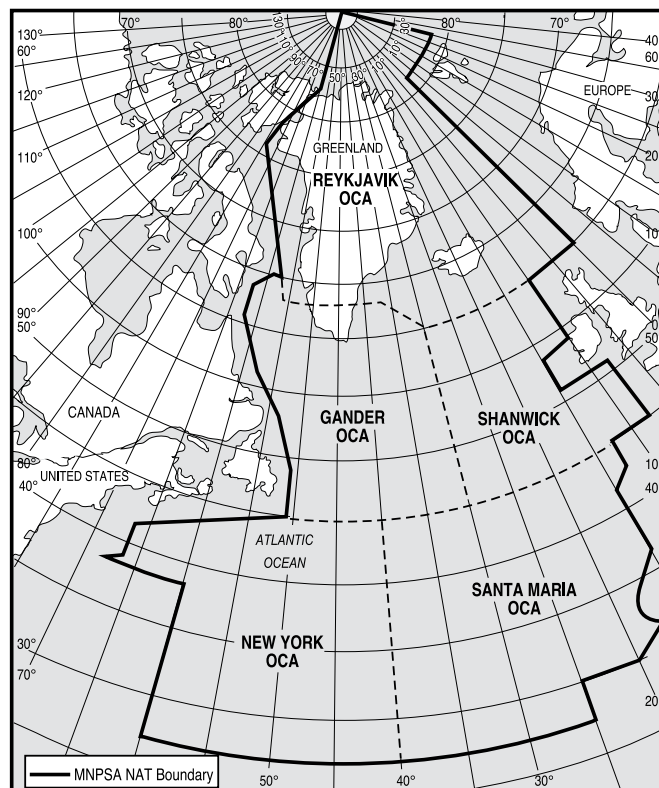

11.20 NORTH ATLANTIC MINIMUM NAVIGATION PERFORMANCE SPECIFICATION AIRSPACE

11.20.1 General

- (a) Compliance with MNPS is required by all aircraft operating within the following defined airspace boundaries:
 - (i) between FL285 and FL420,
 - (ii) between latitudes 27°N and the North Pole,
 - (iii) bounded in the east, by the eastern boundaries of CTAs Santa-Maria, Shanwick Oceanic and Reykjavik, and
 - (iv) in the west, by the western boundaries of CTAs Reykjavik and Gander and New York Oceanic, excluding the area west of 60°W and south of 38°30'N.
- (b) Operators of Canadian-registered aircraft intending to fly in MNPS airspace will be required to show that they meet

all the applicable standards. Information on the measures necessary to gain approval may be obtained from:

Equipment Installation Approval:

Transport Canada Safety and Security
Regional Airworthiness Engineer
(See GEN 1.0 for the appropriate Regional Office)

Operating Standards Commercial Air Carriers and Private Operators:

Transport Canada Safety and Security
Director, Commercial and Business Aviation (AARX)
Ottawa ON K1A 0N8
Fax: 613 954-1602

- (b) Machrihanish, Belfast, Glasgow, Shannon – 57°N 10°W – 60°N 15°W – 61°N 16’30’’ BREKI – Keflavik;
- (c) Keflavik – GIMLI – Kulusuk – Sondre Stromfjord – FROBAY;
- (d) Keflavik – EMBLA – 63°N 30°W – 61°N 40°W – Prins Christian Sund;
- (e) Prins Christian Sund – 59°N 50°W – PRAWN – NAIN;
- (f) Prins Christian Sund – 59°N 50°W – PORGY – Hopedale;
- (g) Prins Christian Sund – 58°N 50°W – LOACH – Goose VOR;
- (h) Sondre Stromfjord – 67°N 60°W – Pangnirtung (YXP);
- (i) Kook Islands – 66°N 60°W – Pangnirtung (YXP);
- (j) Kook Islands – 64°N 60°W – 64°N 63°W (LESAM) – FROBAY; and
- (k) Reykjaneskoli – 69°30’N 22°40’W – Constable Pynt.

11.20.2 Time Keeping Procedures

Prior to entry into MNPS airspace, the time reference system(s) to be used during the flight for calculation of way point Estimated Times of Arrival (ETAs) and way point Actual Times of Arrival (ATAs) should be synchronized to UTC. All ETAs and ATAs passed to ATC should be based on a time reference that has been synchronized to UTC or equivalent. Acceptable sources of UTC include the following:

- (a) WWV – National Institute of Standards and Technology (NIST: Fort Collins, Colorado, U.S.). WWV operates 24 hours a day on 2500, 5000, 10000, 15000, 20000 kHz (AM/SSB) and provides UTC voice every minute;
- (b) GPS (corrected to UTC) – Available 24 hours a day to those pilots that can access the time via approved on board GPS (TSO-C129) equipment;
- (c) CHU – National Research Council (NRC: Ottawa, Canada). Available 24 hours a day on 3330, 7850, 14670 kHz (SSB). In the final ten-second period of each minute, a bilingual station identification and time announcement is made in UTC;
- (d) BBC – British Broadcasting Corporation (Greenwich, U.K.). The BBC transmits on a number of domestic and worldwide frequencies and transmits the Greenwich time signal (referenced to UTC) once every hour on most frequencies, although there are some exceptions;
- (e) Any other source shown to the State of Registry or State of Operator (as appropriate) to be an equivalent source of UTC.

These routes are subject to the following conditions:

- (i) sufficient navigation capability remains to meet the MNPS and the requirements in ICAO Annex 6, Part I, Chapter 7 (sec. 3) and ICAO Annex 6, Part II, Chapter 7 (sec. 2) can be met by relying on the use of short-range navigation aids,
- (ii) a revised flight plan is filed with the appropriate ATS unit, and
- (iii) an ATC clearance is obtained.

- NOTES**
- 1: A revised oceanic clearance will be issued after co-ordination between all oceanic ACCs concerned.
 - 2: If the organized track system extend to the northern part of the NAT Region, the aircraft concerned may be required to accept a lower than optimum flight level in the revised oceanic clearance, especially during peak traffic periods.
 - 3: This guidance material does not relieve the pilot to take the best possible course of action in light of the prevailing circumstances.

11.20.3 Provisions for Partial Loss of Navigation Capability

If an aircraft suffers partial loss of navigation capability (only one long-range navigation system serviceable) prior to entry into oceanic airspace, the following routes should be considered:

- (a) Stornoway – 60°N 10°W – 61°N 12°34’W – ALDAN – Keflavik;

Benbecula – 61°N 10°W – ALDAN – Keflavik;

11.20.4 Special Routes for Aircraft Fitted with a Single Long-Range Navigation System

Aircraft, having State approval for operating in MNPS airspace, which are equipped with normal short-range navigation equipment (VOR/DME, ADF) and at least one fully operational set of one of the following navigation equipment are considered capable of meeting the MNPS while operating along the following routes:

- (a) Equipment
 - (i) DOPPLER with computer;
 - (ii) INS;

RAC

- (iii) GPS approved in accordance with the requirements specified in Technical Standard Order (TSO) C-129 (Class A1, A2, B1, B2, C1, or C2); and
 - (iv) Flight Management System (FMS) or Inertial Reference System (IRS).
- (b) Routes (referred to as Blue Spruce routes)
- (i) Stornoway – 60°N 10°W – 61°N 12°34'W – ALDAN – Keflavik (HF required on this route), Benbecula – 61°N 10°W – ALDAN – Keflavik [VHF coverage exists and, subject to prior co-ordination with Scottish Airways and Prestwick (Shanwick OACC), this route may be used by non-HF equipped aircraft],
 - (ii) Machrihanish, Belfast, Glasgow, Shannon – 57°N 10°W – 60°N 15°W – 61°N 16°30'W – BREKI Keflavik (HF required on this route),
 - (iii) Keflavik – GIMLI – Kulusuk – Sondre Stromfjord – FROBAY,
 - (iv) Keflavik – EMBLA – 63°N 30°W – 61°N 40°W – Prins Christian Sund,
 - (v) Prins Christian Sund – 59°N 50°W – PRAWN – NAIN,
 - (vi) Prins Christian Sund – 59°N 50°W – PORGY – Hopedale,
 - (vii) Prins Christian Sund – 58°N 50°W – LOACH – Goose VOR,
 - (viii) Sondre Stromfjord – 67°N 60°W – Pangnirtung (YXP),
 - (ix) Kook Islands – 66°N 60°W – Pangnirtung (YXP)
 - (x) Kook Islands – 64°N 60°W – 64°N 63°W (LESAM) – FROBAY,
 - (xi) Reykjanesskoli – 69°30'N 22°40'W – Constable Pynt,
 - (xii) Cork – 50°N 09°W – 49°N 09°W – 45°N 09°W – Santiago VOR
Lands End – 51°N 08°W (HF required on this route),
 - (xiii) Funchal/Porto Santo – Santa Maria/Ponta Delgada, and
 - (xiv) Lisboa Porto Faro – Ponta Delgada/Santa Maria/Lajes

11.20.5 Special Routes for Aircraft Fitted with Short-Range Navigation Equipment Operating Between Iceland and Other Parts of Europe

Aircraft having State approval for operating in MNPS airspace provided with normal short-range navigation equipment (VOR/DME, ADF) operating on the routes below and within MNPS airspace are considered capable of meeting the MNPS.

- (a) Flesland – Myggenes – INGO – Keflavik (G3); and
- (b) Sumburgh – Akraberg – Myggenes (G11).

11.20.6 Aircraft Without MNPS Capability

- (a) Non-approved MNPS aircraft will not be issued a clearance to enter into MNPS airspace.
- (b) Non-approved MNPS aircraft may be cleared to climb or descend through MNPS airspace provided:
 - (i) the climb or descent can be completed within 200 NM of the Gander VORTAC (YQX), St. John's, VOR/DME (YYT), St. Anthony VOR/DME (YAY), Goose VOR/DME (YYR), or within the radar coverage of Gander, Moncton and Montréal ACCs; and
 - (ii) MNPS aircraft affected by such a climb or descent are not penalized.

11.20.7 Monitoring of Gross Navigation Errors

- (a) In order to ensure that the required navigation standards are being observed within the MNPSA, a continuous monitoring of the navigation accuracy of aircraft in this airspace takes place using radars in Canada, Ireland, France, Iceland and the United Kingdom. In cases of a gross navigation error, the pilot will normally be notified by the ATC unit observing the error. The subsequent investigation to determine the error will involve the ATC unit, the operator and the State of Registry.
- (b) If there is a serious increase in the number of large errors, it may become necessary to increase separation standards until remedial action has been determined. Alternatively, if rapid corrective action cannot be achieved, it may be necessary for the State of Registry or the State of the Operator to temporarily exclude offending types of aircraft or operators from the MNPS airspace.

11.21 NORTH ATLANTIC REDUCED VERTICAL SEPARATION MINIMUM

11.21.1 General

In the North Atlantic, Reduced Vertical Separation Minimum (RVSM) airspace is that airspace within the geographic extent of the NAT Region from FL290 to FL410 inclusive.

11.21.2 RVSM Details and Procedures

For RVSM details and procedures applicable to both the NAT and Canadian Domestic airspace see RAC 12.17.

11.21.3 Flight Level Allocation Scheme

11.21.3.1 Flight Level Availability

Following statistical analysis and discussions between the NAT ATS Units, it was decided that the North Atlantic Flight Level Allocation System will:

- (a) utilise additional levels made available by RVSM expansion;

- (b) standardize the flight level profiles available for eastbound traffic originating in the New York/Santa Maria areas during the eastbound flow, with a view to incorporating the functionality of automated data transfer links; and
- (c) ensure that economic profiles are available for westbound aircraft routing from the Reykjavik OAC.

11.21.3.2 Procedures

The procedures entail the establishment of a night datum line, south of which is reserved principally for traffic originating in New York/Santa Maria.

The procedures entail the establishment of a north datum line, on or north of which is reserved for late-running westbound traffic from Reykjavik to Gander.

Aircraft operators are advised to flight plan using the flight levels specified in this document, relative to their particular flight(s).

These procedures involve dedicating particular flight levels to eastbound traffic and allocating these flight levels to specific OACs, using the night datum line.

The westbound OTS message will be published using FL310 to FL390. Gander will publish the eastbound OTS message using FL310 to FL400. However, FL310 will only be used for "New York tracks" (see section 11.21.3.4).

The hours of validity for the westbound (day-time) OTS shall be published as 1130 to 1900 UTC at 030°W.

The hours of validity for the eastbound (night-time) OTS shall be published as 0100 to 0800 UTC at 030°W.

11.21.3.3 Delegated Opposite Direction Levels (ODL)

Gander will accept FL310 as a westbound flight level 24 hours a day, subject to eastbound Caribbean (CAR)/South American (SAM) traffic, as described in section 11.21.3.4.

During the eastbound OTS hours of validity, a static datum line, known as the night datum line, is established with the following co-ordinates:

45°N 030°W 49°N 020°W SOMAX KENUK

FL360 and FL380 are delegated to Gander for use by eastbound traffic on and to the north of the night datum line.

FL360 will not be used for Gander eastbound traffic to the south of the night datum line.

FL380 will not be used for Gander eastbound traffic to the south of the night datum line or the eastbound OTS, whichever is further south.

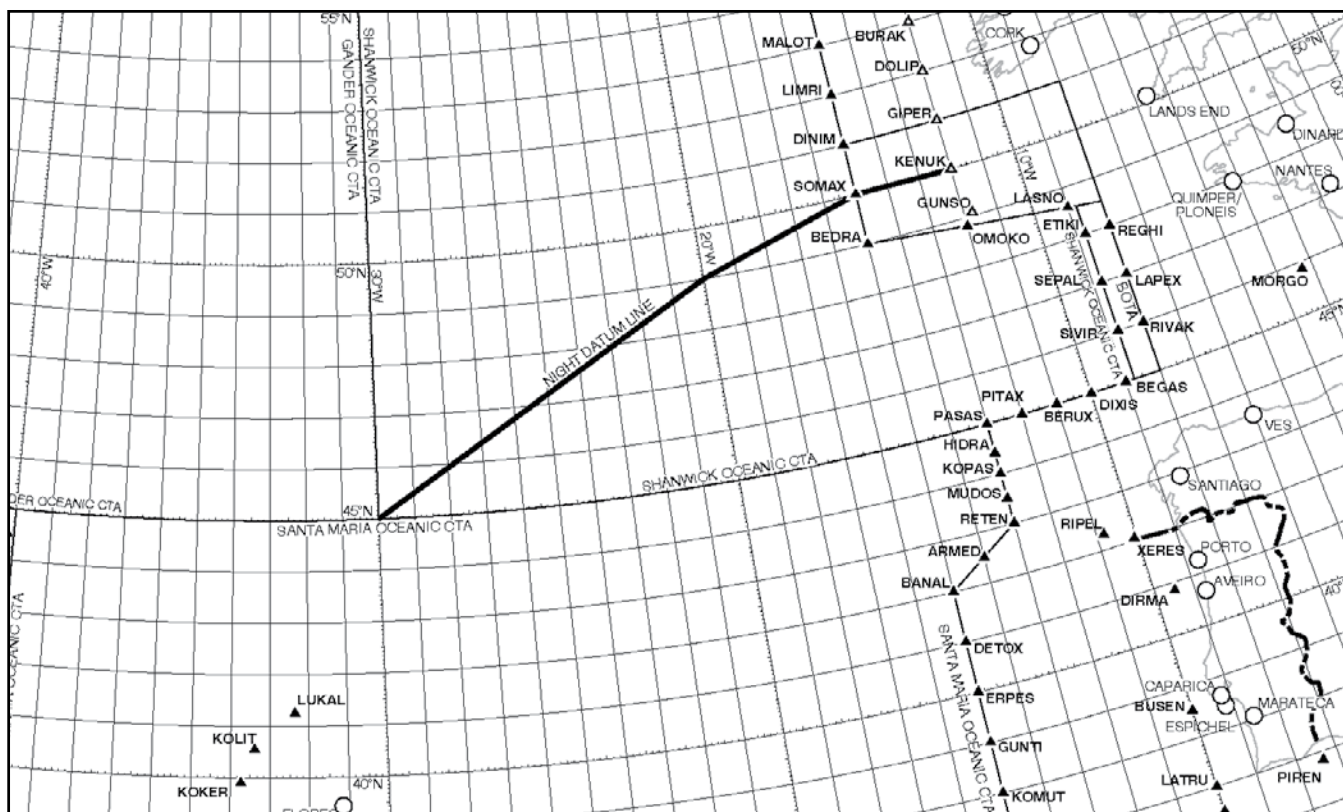

RAC

During the westbound OTS hours of validity, Gander delegates FL330 to Shanwick for use by westbound traffic.

On and to the north of the north datum line, FL380 is delegated to Reykjavik for use by westbound traffic.

Between 0300 and 0700 UTC, a static datum line, known as the north datum line, is established with the following co-ordinates:

In the event of a high volume of north random flights and/or OTS tracks, the north datum line may be suspended to accommodate the anticipated eastbound traffic demand.

**LOMTA MOATT 60°N 050°W 62°N 040°W
63°N°030°W**

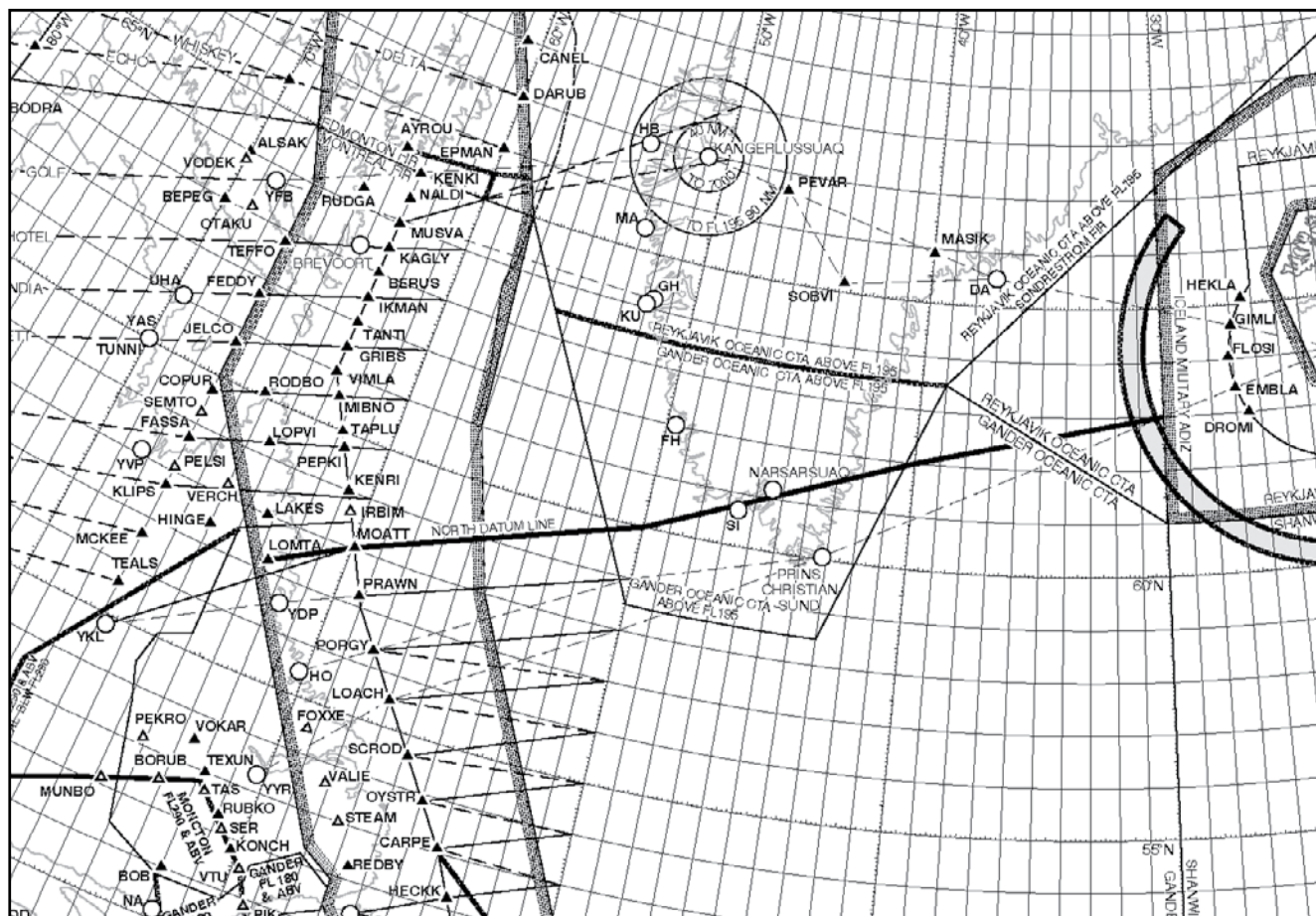

RAC

11.21.3.4 Eastbound Traffic Originating in New York/Santa Maria During Eastbound OTS Hours of Validity

Eastbound traffic routing south of both the night datum line and the main OTS should flight plan using FL310, FL340, FL360 or FL380.

Eastbound traffic remaining south of the night datum line should flight plan using FL310 or FL360. The flight levels allocated to New York tracks entering Shanwick OCA that cross, or route south of, the night datum line may be any combination of FL310, FL340, FL360 and FL380, as agreed between Santa Maria and New York.

For this procedure, “New York tracks” are eastbound OTS tracks that originate in the New York area and are separated from the main OTS by more than one degree at 030°W.

11.21.3.5 Iberian Tracks

Iberian tracks are eastbound or westbound organized tracks, routing between New York and Santa Maria, which do not enter Gander or Shanwick airspace.

The flight levels allocated to Iberian tracks will be any combination of FL330, FL350 and FL370, as agreed between Santa Maria and New York.

11.21.3.6 OTS Design and Use

For all westbound tracks that landfall at or north of PRAWN, Reykjavik OAC requires FL340 to be omitted from those tracks to allow profiles for aircraft originating in the Reykjavik OCA. During the westbound OTS hours of validity, controllers at Shanwick shall not clear westbound aircraft that landfall at or north of PRAWN at FL340, except for random

flights that cross 61°N at or east of 020°W and route at or north of 63°N 030°W.

11.21.3.7 OTS Changeover Periods

The time period between one OTS expiring and another set commencing is known as the OTS changeover period. The following procedures are in place to accommodate the majority of aircraft.

Basic principles

All times relate to 030°W.

OTS changeover rules apply from 0801 to 1129 UTC and from 1901 to 0059 UTC. During these times, flight levels shall be applied in accordance with the direction of flight except as stated below.

General principles

Westbound traffic crossing 030°W from 2230 to 0059 UTC shall remain clear of the incoming OTS and shall not use delegated opposite direction levels (ODL) (FL360 and FL380). After 2230 UTC, the OTS and ODLs (FL360 and FL380) are released to Gander, who may clear eastbound aircraft, taking into account and giving priority to already cleared westbound aircraft.

Eastbound traffic crossing 030°W from 1000 to 1129 UTC shall remain clear of the incoming OTS at FL350 and shall not use the delegated ODL (FL330). After 1000 UTC, the OTS (at FL330 and FL350) and ODL (FL330) are released to Shanwick, who may clear westbound aircraft, taking into account and giving priority to already cleared eastbound aircraft.

Eastbound traffic at FL370 and FL390 and crossing 030°W from 1030 to 1129 UTC shall remain clear of the incoming OTS. After 1030 UTC, the OTS (at FL370 and FL390) are released to Shanwick, who may clear westbound aircraft, taking into account and giving priority to already cleared eastbound aircraft.

At the end of westbound (day-time) OTS, westbound aircraft crossing 030°W up until 1900 UTC at the ODL (FL330) or on the OTS shall have priority over eastbound aircraft. Eastbound aircraft shall be cleared by Shanwick, taking into account and giving priority to already cleared westbound aircraft.

At the end of eastbound (night-time) OTS, eastbound aircraft crossing 030°W up until 0800 UTC at the ODLs (FL360 and FL380) or on the OTS shall have priority over westbound aircraft. Westbound aircraft shall be cleared by Gander, taking into account and giving priority to already cleared eastbound aircraft.

The table below summarises the above:

Level	Time (UTC)	Direction
FL430	24 hours	Westbound May be flight planned as eastbound by non-RVSM aircraft.
FL410	24 hours	Eastbound
FL400	0801-2229 2230-0059 0100-0800	Westbound Westbound (avoiding OTS) Eastbound OTS (subject to westbounds) Westbound (avoiding OTS) Eastbound (OTS)
FL390	1901-1029 1030-1129 1130-1900	Eastbound Eastbound (avoiding OTS) Westbound OTS (subject to eastbounds) Eastbound (avoiding OTS) Westbound (OTS)
FL380	0300-0700 0801-2229 2230-0059 0100-0800	Westbound (ODL) Westbound Eastbound (subject to westbounds) Eastbound (OTS and ODL)
FL370	1901-1029 1030-1129 1130-1900	Eastbound Eastbound (avoiding OTS) Westbound OTS (subject to eastbounds) Eastbound (avoiding OTS) Westbound (OTS)
FL360	0801-2229 2230-0059 0100-0800	Westbound Eastbound (subject to westbounds) Eastbound (OTS and ODL)
FL350	1901-0959 1000-1129 1130-1900	Eastbound Eastbound (avoiding OTS) Westbound OTS (subject to eastbounds) Eastbound (avoiding OTS) Westbound (OTS)
FL340	0801-2229 2230-0059 0100-0800	Westbound Westbound (avoiding OTS) Eastbound OTS (subject to westbounds) Westbound (avoiding OTS) Eastbound (OTS)
FL330	1901-0959 1000-1129 1130-1900	Eastbound Westbound (subject to eastbounds) Westbound (OTS and ODL)
FL320	0801-2229 2230-0059 0100-0800	Westbound Westbound (avoiding OTS) Eastbound OTS (subject to westbounds) Westbound (avoiding OTS) Eastbound (OTS)
FL310	24 hours	Westbound
FL300	24 hours	Westbound
FL290	24 hours	Eastbound



11.21.4 NAT RVSM Aircraft Approvals

- (a) An aircraft will not be permitted to operate at RVSM designated altitudes until RVSM (operational) approval has been awarded.
- (b) For group aircraft to be approved for NAT RVSM operations, it is required to:
 - (i) have MNPS (horizontal navigation performance) approval;
 - (ii) obtain RVSM airworthiness approval (MASPS compliant); (iii) demonstrate acceptable height-keeping performance through monitoring; and
 - (iv) obtain RVSM (operational) approval from the aircraft State authority.
- (c) For non-group aircraft, operators must apply for operating authority individually. Monitoring by an HMU or GMU is a prerequisite to obtain RVSM (operational) approval unless flight test evidence can be provided to the State to show that each airframe is compliant with Altimetry System Error (ASE) targets.
- (d) Operators of Canadian-registered aircraft intending to fly in NAT MNPS/RVSM airspace will be required to show that they meet all of the applicable standards. Further information on the measures necessary to gain approval may be obtained from the following:

Airworthiness Approvals

Transport Canada Safety and Security
 Director, Aircraft Certification (AARD)
 Ottawa ON K1A 0N8
 Fax:613 996-9178

Operational Standards – Commercial Air Carriers and Private Operators

Transport Canada Safety and Security
 Director, Commercial and Business Aviation (AARX)
 Ottawa ON K1A 0N8
 Fax: 613 954-1602

RVSM Maintenance Programs

Transport Canada Safety and Security
 Director, Aircraft Maintenance and Manufacturing (AARP)
 Ottawa ON K1A 0N8
 Fax:613 996-9178

11.21.5 Central Monitoring Agency (CMA)

- (a) The Regional Monitoring Agency for the NAT is the Central Monitoring Agency (CMA) located in Prestwick, U.K. and may be contacted as follows:
 North Atlantic Central Monitoring Agency
 c/o National Air Traffic Services
 Room G41
 Scottish & Oceanic Area Control Centre,
 Sherwood Road,
 Prestwick,
 Ayrshire
 KA9 2NR
 United Kingdom

 Tel:+44 (0) 1292 692412
 HMU Status (recorded message)+44 (0) 1292 692760
 Fax:+44 (0) 1292 692754
 E-mail:.....*natcma@nats.co.uk*
- (b) Information on the responsibilities and procedures applicable to the CMA are contained in “ICAO, NAT Doc 001 – Guidance and Information Material concerning Air Navigation in the North Atlantic Region” and through the internet at *http://www.paris.icao.int/*.

11.21.6 Height Monitoring

For the NAT, height monitoring is carried out using a hybrid system comprising a fixed ground-based height monitoring unit (HMU) and a GPS-based monitoring system comprising portable GPS monitoring units (GMU).

11.21.7 Height Monitoring Unit (HMU)

- (a) The HMU site is located at Strumble, UK—15 NM east of the Strumble VOR/DME (STU), beneath Upper ATS UG1, at co-ordinates 51°56’00”N 04°40’00”W (Figure 11.3).
- (b) The coverage area for the Strumble HMU is a 13.8 NM radius circle from FL290 to FL410 inclusive.

Figure 11.3—Strumble HMU

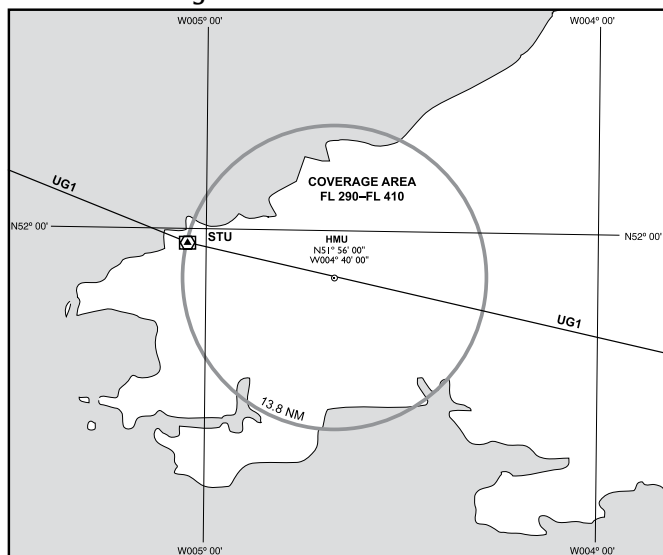

Pre-flight Procedures

- (a) Operators proposing to divert from an optimum route in order to fly over the Strumble HMU should check the HMU status at 44 171 832-6031 (UK) for serviceability information. Every effort will be made to ensure that the promulgated information is accurate, but operators should note that the equipment may become unserviceable on short notice.
- (b) Aircraft for monitoring should be flight planned to route over STU. Item 18 of the flight plan is to include both the aircraft registration (if not included in Item 7) and the remarks “RMK/HMU FLT STU.”

In-flight Procedures

Prior to an over-flight of an HMU, pilots are requested to transmit “for HMU flight” to London Control on initial contact. Operational requirements permitting, ATC will endeavour to accommodate the flight.

Post-flight Procedures

- (a) ATC is not aware whether an aircraft has been successfully monitored by the HMU. Operators wishing to ascertain this information may send a fax to the NAT CMA.
- (b) Operator queries for specific over-flights may be made to the NAT CMA. Such queries should include the Mode S or A codes and approximate time of over-flight.

11.21.8 GMU Monitoring

- (a) GMUs are available for those aircraft that do not wish to be monitored by overflying an HMU.
- (b) For GMU services to conduct a height-monitoring flight see RAC 12.16.9.

11.21.9 Further Information

Information on the RVSM program is available on the Internet by visiting the ARINC bulletin board at <<http://www.arinc.com>> and calling up the RVSM pages. Aircraft that are successfully monitored will be promulgated via the bulletin board. Operators will be notified by fax or telephone of individual access codes on the first occasion that its aircraft are placed on the board. More information may be obtained by contacting ARINC Inc.:

Tel.: 410 266-4891;
 Fax: 410 573-3007.

11.22 STRATEGIC LATERAL OFFSET PROCEDURES (SLOP) IN THE NORTH ATLANTIC

The Strategic Lateral Offset Procedure (SLOP) is now a standard operating procedure throughout the North Atlantic (NAT) Region. This procedure mitigates collision risk and wake turbulence encounters. Pilots conducting oceanic flights within the NAT Region with automatic offset programming capability are recommended to fly lateral offsets of either 1 or 2 NM right of centreline.

The introduction of very accurate aircraft navigation systems, along with sophisticated flight management systems, has drastically reduced the number of risk bearing lateral navigation errors reported in NAT airspace. Paradoxically, the capability of aircraft to navigate to such a high level of accuracy has led to a situation where aircraft on the same track but at different levels, are increasingly likely to be in lateral overlap. This results in an increased risk of collision if an aircraft departs from its cleared level for any reason.

SLOP reduces risk by distributing aircraft laterally. It is applicable within the New York Oceanic, Gander Oceanic, Shanwick Oceanic, Santa Maria Oceanic, Søndrestrom and Reykjavik flight information regions, and within the Bodø Oceanic flight information region when flights are operated more than 185 km (100 NM) seaward from the shoreline.

SLOP conforms to direction in the International Civil Aviation Organization’s (ICAO) Procedures for Air Navigation Services—Air Traffic Management (PANS—ATM, Doc 4444, 15.2.4) and is subject to the following guidelines:

- Aircraft without automatic offset programming capability must fly the route centreline.
- Operators capable of programming automatic offsets may fly the centreline or offset one or two nautical miles right of centreline, allowing for 3 possible positions along

RAC

route. Offsets are not to exceed 2 NM right of centreline and offsets to the left of centreline are not permitted. An aircraft overtaking another aircraft should offset within the confines of this procedure, if capable, so as to create the least amount of wake turbulence for the aircraft being overtaken. The pilot should take into account wind and estimated wake vortex drift and time to descend. (Nominal descent rates for wakes are 300-600 fpm.)

- Pilots should use whatever means are available (e.g., TCAS, communications, visual acquisition) to determine the best flight path to fly. Pilots may contact other aircraft on frequency 123.45, as necessary, to coordinate the best wake turbulence offset option.
- Pilots may apply an offset outbound after the oceanic entry point and must return to centreline before the oceanic exit point. Position reports transmitted via voice should be based on the waypoints of the current ATC clearance and not the offset positions.
- Aircraft transiting oceanic radar areas may remain on their established offset positions.
- There is no ATC clearance required for this procedure and it is not necessary that ATC be advised.

12.0 AIR TRAFFIC CONTROL (ATC) SPECIAL PROCEDURES

12.1 ADHERENCE TO MACH NUMBER

- (a) Within CDA, aircraft shall adhere to the Mach number assigned by ATC, to within 0.01 Mach, unless approval is obtained from ATC to make a change or until the pilot receives the initial descent clearance approaching destination. If it is necessary to make an immediate temporary change in the Mach number (e.g. because of turbulence), ATC shall be notified as soon as possible that such a change has been made.
- (b) If it is not possible to maintain the last assigned Mach number during en route climbs and descents because of aircraft performance, pilots shall advise ATC at the time of the climb/descent request.

12.2 PARALLEL OFFSET PROCEDURES

- (a) ATC may request that an aircraft fly a parallel offset from an assigned route. This manoeuvre and subsequent navigation is the responsibility of the pilot. When requested to offset or regain the assigned route, the pilot should change heading by 30° to 45° and report when the offset or assigned route is attained.
- (b) In a radar environment, ATC will provide radar monitoring and the required separation.

- (c) In a non-radar environment, ATC will apply parallel offsets to RNP-certified aircraft operating within high-level RNP airspace in order to accomplish an altitude change with respect to same direction aircraft.
- (d) The following phraseology is normally used for parallel offset procedures:
PROCEED OFFSET (number) MILES (right/left) OF CENTRELINE (track/route) AT (significant point/time) UNTIL (significant point/time).

12.3 STRUCTURED AIRSPACE

During specific periods, certain portions of domestic high-level airspace may be structured for one-way traffic in which cruising flight levels inappropriate to the direction of the aircraft track may be assigned by ATC. Aircraft operating in a direction contrary to the traffic flow will be assigned those cruising flight levels appropriate to the direction of track except in specific instances, such as turbulence. When the airspace is not structured for one-way traffic, appropriate cruising flight levels will be used. ATC will transition aircraft to the appropriate cruising flight level for the direction of track before aircraft exit the defined areas or before termination of the indicated times.

12.4 REQUIRED NAVIGATION PERFORMANCE CAPABILITY (RNP) AIRSPACE

12.4.1 Definition

- (a) RNP airspace is that controlled airspace within the CDA as defined in the *Designated Airspace Handbook* (DAH) (TP 1820E). This airspace is established to accommodate RNAV operations and is contained within the SDA and NCA.
- (b) To conduct RNAV operations (fixed or random routes) in the designated airspace, in which reduced ATC separation criteria can be applied, the required aircraft navigation equipment must be certified as being capable of navigating within specified tolerances.
- (c) Separation in accordance with RNP may be applied for flights within those portions of the Gander Oceanic and New York Oceanic FIR that are designated part of the Gander Domestic or Moncton Domestic CTA.

12.4.2 Aircraft Navigation Equipment for RNP

- (a) Only aircraft certified by the State of Registry or the State of the Operator as meeting the RNP are permitted to conduct RNAV operations.
- (b) Long range RNAV systems must be certified and capable of navigation performance that permits position determination within ± 4 NM. Such navigation performance capability shall be verified by the State of Registry or the State of the Operator, as appropriate.

- (c) Aircraft that have the required navigation equipment for operations in CMNPS and NAT MNPS airspaces satisfy all requirements for RNP.
- (d) The minimum navigation equipment for RNP operation is one certified long range RNAV system, plus a short range navigation system (VOR/DME or ADF).

12.4.3 Operator Certification for RNP

- (a) The requirement for operator certification for RNP does not apply to general aviation. RNP operator certification applies only to air, private and foreign operators conducting RNP operations. Certification of operators is dependent upon crew training and navigation equipment that meets the applicable *Commercial Air Service Standards* or *Private Operator Passenger Transportation Standards*. Such navigation performance capability shall be verified by the State of Registry or the State of the Operator, as appropriate.
- (b) Canadian operators intending to operate in RNP airspace using RNAV operations should contact the following for details of the certification requirements:

Equipment and Installation Approval

Transport Canada Safety and Security
 Regional Aircraft Certification Engineer
 (See GEN 1.0 for the appropriate regional office.)

Operating Standards Approval

Transport Canada Safety and Security
 Director, Commercial and Business Aviation (AARX)
 Tower C, Place de Ville
 Ottawa ON K1A 0N8

Fax: 613-954-1602

12.4.4 Flight Planning Procedure

If operating in RNP and conducting RNAV operations, flights may indicate one of the combinations in this table. The use of the equipment suffix “R” followed by the Performance Based Navigation in item 18 of the flight plans is acceptable for RNP. The use of equipment suffix “X” (MNPS certification) and CMNPS (reference 12.5.5) are acceptable in lieu of RNP certification.

RNP Field 10 a	Field 18	Certification Specification
X		MNPS
G	NAV/	Indicate GNSS augmentation if any are specified
I		Inertial Navigation
R	PBN/A1	RNAV10 (RNP10)
R	PBN/L1	RNP4
R	PBN/B1	RNAV5 all permitted sensors
R	PBN/B2	RNAV5 GNSS
R	PBN/B2B3	RNAV5 GNSS + RNAV5 DME/DME
R	PBN/B2B4	RNAV5 GNSS + RNAV5 VOR/DME
R	PBN/B3B4	RNAV5 DME/DME + RNAV5 VOR/DME
R	PBN/B3B5	RNAV5 DME/DME + RNAV5 INS/IRS
R	PBN/B4B5	RNAV5 VOR/DME + RNAV5 INS/IRS
R	PBN/B5	RNAV5 INS/IRS
R	PBN/C1	RNAV2 all permitted sensors
R	PBN/C2	RNAV2 GNSS
R	PBN/C2C3	RNAV2 GNSS + RNAV2 DME/DME
R	PBN/C4	RNAV2 DME/DME/IRU

12.4.5 RNAV/DME Distance

ATC requests for distance information from RNAV-certified aircraft shall be based on RNAV distances. DME based on TACAN or VOR/DME shall be used only if ATC indicates such information in the request.

12.4.6 RNAV Equipment Failure Procedures

RNAV operations and the associated ATC separation minima depend upon the accuracy of the RNAV systems. ATC is to be advised immediately at any time that a pilot is uncertain of the aircraft position or of an on-board navigation system failure or degradation.



12.5 CMNPS AIRSPACE

12.5.1 Definition

- (a) CMNPS airspace is that controlled airspace within CDA, between FL 330 and FL 410 inclusive, as defined in the DAH (TP 1820E) and depicted in Figure 12.1. This airspace is contained for the most part in the ACA and NCA, with a small portion in the SCA.
- (b) To conduct RNAV operations in CMNPS airspace, in which reduced ATC separation criteria can be applied, aircraft must be certified as being capable of navigating within specified tolerances.

12.5.2 CMNPS Transition Airspace

In order to permit both CMNPS-certified and non-certified aircraft to operate above FL 270, a transition area exists from FL 270 to below FL 330 underlying the lateral limits of CMNPS airspace.

Figure 12.1—CMNPS, RNP and CMNPS Transition Airspace

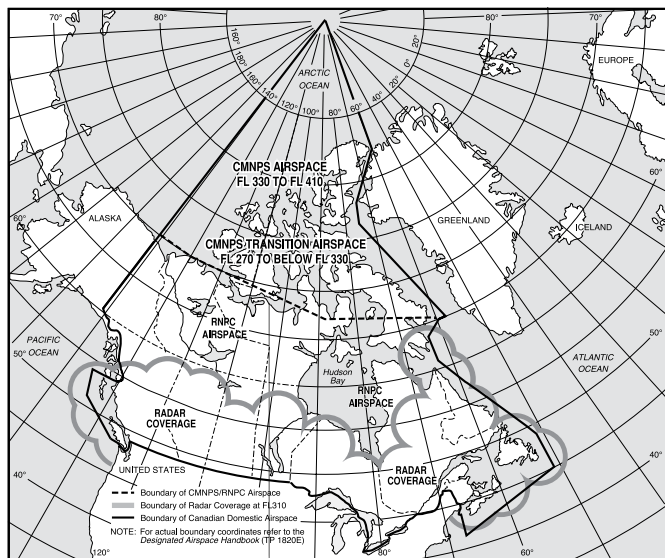

12.5.3 Aircraft Navigation Equipment for CMNPS

- (a) Only aircraft with navigation equipment certified by the State of Registry or the State of the Operator as meeting the MNPS of either the NAT or Canada are permitted to operate within CMNPS airspace, unless the ATC unit concerned indicates that the non-certified aircraft may be accommodated without penalizing certified aircraft.
- (b) Required long range RNAV systems must be certified and shown capable of navigation performance such that:
 - (i) the standard deviation of lateral track errors is less than 6.3 NM;
 - (ii) the proportion of total flight time spent by aircraft 30 NM or more off the cleared track is less than

5.3×10^{-4} (i.e. less than 1 hr in about 2 000 flight hours); and

- (iii) the proportion of total flight time spent by aircraft between 50 and 70 NM off the cleared track is less than 13×10^{-5} (i.e. less than 1 hr in about 8 000 flight hours).
- (c) Such navigation performance capability shall be verified by the State of Registry or the State of the Operator, as appropriate. Aircraft that operate within designated airways and company-approved routes, that are completely in signal coverage of ground-based NAVAIDs, satisfy CMNPS requirements when operating within the protected airspace for airways and company-approved routes.
- (d) The following minimum navigation systems may be deemed to satisfy the CMNPS:
 - (i) Aircraft transiting CDA to/from another continent must be equipped with two long range RNAV systems or one navigation system using the inputs from one or more sensor systems, plus one short range navigation system (ADF, VOR/DME).
 - (ii) Aircraft operating within North America on routes that lie within reception of ground-based NAVAIDs must be equipped with a single long range RNAV system, plus a short range navigation system (ADF, VOR/DME).
 - (iii) Aircraft operating on high-level airways or company-approved routes must be equipped with dual short range navigation systems (ADF, VOR/DME).

12.5.4 Operator Certificate for CMNPS

- (a) CMNPS operator certification applies only to air, private and foreign operators conducting CMNPS operations. Certification of operators is dependent on crew training and navigation equipment that meets the applicable *Commercial Air Service Standard* or *Private Operator Passenger Transportation Standard*. Such navigation performance capability shall be verified by the State of Registry or the State of the Operator, as appropriate.
- (b) Canadian operators intending to operate in CMNPS airspace should contact the following for details of certification requirements:

Equipment and Installation Approval

Transport Canada Safety and Security
Regional Aircraft Certification Engineer
(See GEN 1.0 for the appropriate regional office.)

Operating Standards Approval

Transport Canada Safety and Security
Director, Commercial and Business Aviation (AARX)
Tower C, Place de Ville
Ottawa ON KIA 0N8
Fax: 613-954-1602

RAC

12.5.5 Flight Planning Procedure

In consideration of the similar equipment and performance requirements associated with current CMNPS, MNPS, RNAV10 and RNP4 approvals, flights shall indicate eligibility to receive service in CMNPS airspace by one of the following:

MNPS: the use of the equipment suffix “X” is acceptable in lieu of CMNPS certification.

CMNPS: the use of the equipment suffix “R” followed by the Performance Based Navigation level “A1” to indicate RNAV10 (RNP10) approval or “L1” to indicate RNP4 approval in item 18 of the flight plan is acceptable for CMNPS.

12.5.6 Partial or Complete Loss of Navigation Capability While Operating within CMNPS Airspace

- (a) CMNPS operations and the associated ATC separation minima depend upon the accuracy of the navigation systems. ATC is to be advised immediately at any time that a pilot is uncertain of the aircraft position, or of an on-board navigation system failure or degradation.
- (b) Upon entry into CMNPS airspace, or as soon as practical thereafter, flight crews are to cross-check the accuracy of their long range RNAV system with information obtained from station-referenced aids. Navigation systems shall be updated if the cross-check indicates such action is considered necessary.

12.5.7 Communications

Aircraft operating in CMNPS airspace are to communicate with ATS facilities as published on the HI 1 and HI 2 charts. Communication with the Edmonton ACC is in the following order of priority:

1. Edmonton Centre on an RCO frequency as published on the HI 1 and HI 2 charts;
2. Arctic Radio on an RCO frequency as published on the HI 1 and HI 2 charts;
3. Gander Radio on HF. SATCOM voice may be used as an alternative to HF when communicating with Gander Radio (see COM 6.6.3); and
4. As a last resort because of limited means of forwarding information, Alert, Nun. (CYLT) (military) on 126.7 MHz or HF 5 680 kHz, 6 706 kHz or 11 232 kHz.

During periods of HF unreliability, the use of SATCOM voice for all communications is strongly encouraged. If unable to establish contact via HF or SATCOM voice, aircraft are to make position reports immediately upon coming within range (approximately 200 NM) of any published VHF facility.

12.6 CANADIAN DOMESTIC ROUTES

12.6.1 General

Within North American Airspace, various route and track systems exist in order to provide effective management of airspace and traffic. Under specified conditions, random routes may be included in a flight plan or requested.

12.6.2 North American Route Program (NRP)

12.6.2.1 Introduction

The North American Route Program (NRP) is a joint FAA and NAV CANADA program that allows air operators to select operationally advantageous routings. The objective of the NRP is to harmonize and adopt common procedures, to the extent possible, applicable to random route flight operations at and above FL290 within the conterminous U.S. and Canada.

The NRP will be implemented through various phases with the end goal of allowing all international and domestic flight operations to participate in the NRP throughout the conterminous U.S. and Canada.

12.6.2.2 Eligibility

Flights may participate in the NRP under specific guidelines and filing requirements:

- (a) provided the flight originates and terminates within conterminous U.S. and Canada; or
- (b) for North Atlantic international flights, provided that they are operating within the North American Route (NAR) System.

12.6.2.3 Procedures

NRP common procedures and specific NAV CANADA requirements are contained in the “Planning” section of the CFS.

12.6.3 Preferred IFR Routes

Preferred IFR routes provide guidance in planning routes, minimize route changes, and allow for an efficient and orderly management of traffic. ATS automated systems and air traffic controllers are increasingly reliant on these routes in planning for a systematic air traffic flow, a process that is critical for reducing delays.

Although flight planning of preferred IFR routes is not mandatory, it is strongly encouraged in the interest of efficient departure, enroute, and arrival ATS. When preferred IFR routes are not utilized, ATC will most often be required to clear flights onto them, resulting in increased communication and processing workload and the potential for readback and FMS input errors.

Procedures for and descriptions of preferred routes are published in the CFS, “Planning” section.

12.6.4 Fixed RNAV Routes

Published fixed RNAV routes can be flight planned for use by aircraft with RNAV capability, subject to any limitations or requirements noted on the en route charts, in applicable advisory circulars, or by NOTAM.

- (a) Q-routes are high-level fixed RNAV routes depicted on En Route High Altitude charts using black dashed lines and require an RNAV system with performance capabilities currently only met by GNSS or distance measuring equipment/inertial reference unit (DME/DME/IRU) systems. DME/DME/IRU navigation may be limited in some parts of Canada owing to navigational facility coverage. In such cases, the routes will be annotated as “GNSS only” on the chart.
- (b) T-routes are low-level controlled fixed RNAV routes depicted on En Route Low Altitude charts using black dashed lines and require GNSS RNAV systems for use. The airspace associated with T-routes extends upward from 2 200 ft AGL, 10 NM either side of the centreline, and does not splay. The MOCA provides obstacle protection for only 6 NM either side of the track centreline and does not splay.
- (c) L-routes are low-level uncontrolled fixed RNAV routes depicted on En Route Low Altitude charts using green dashed lines and require GNSS RNAV systems for use. The MOCA provides obstacle protection for only 6 NM either side of the track centreline and does not splay.

Magnetic reference bearing (MRB) is the published bearing between two waypoints on a fixed RNAV route and will be published within the SDA. The MRB is calculated by applying magnetic variation at the waypoint to the calculated true course between two waypoints. Pilots should use this bearing as a reference only, because RNAV systems will fly the true course between the waypoints.

True reference bearings (TRB) will be published along fixed RNAV routes located in the NDA and shall be notated with the suffix “T.”

12.6.5 Northern Control Area Random Routes

Within the Northern Control Area (NCA), flights operating on random routes shall flight plan and make positions reports as follows:

- (a) flights operating on predominately north or south tracks (315°T clockwise through 045°T or the reciprocals) shall report over reporting line points formed by the intersection of parallels of latitude spaced at 5° intervals expressed in latitude by whole degrees and meridians of longitude expressed in either whole degrees or whole and half degrees;
- (b) south of 75°N latitude, flights operating on predominately east or west tracks (046°T clockwise through 134°T or the reciprocals) shall report over reporting line points formed by the intersection of either whole degrees or whole and half degrees of latitude coincident with each 10° of longitude. For flights operating north of 75°N latitude, where 20° of longitude is traversed in less than 60 min, reporting line points are to be defined by parallels of latitude expressed in degrees and minutes coincident with meridians of longitude at 20° intervals;
- (c) as requested by ATS.

12.6.6 Arctic Control Area Random Routes

Within the Arctic Control Area (ACA), flights operating on random routes shall flight plan and make positions reports as follows:

- (a) at the reporting lines coincident with 141°W, 115°W and 60°W meridians. If the route of flight is north of 87°N latitude, the 115°W report is not required;
- (b) westbound flights which do not cross the 60°W meridian on entry or prior to entry into the ACA shall report at the point of entry into the ACA;
- (c) westbound flights which do not cross the 141°W meridian prior to exiting the ACA shall report at the point of exit from the ACA;
- (d) eastbound flights which do not cross the 141°W meridian on entry into the ACA shall report at the point of entry;
- (e) eastbound flights which do not cross the 60°W meridian on or after exiting the ACA shall report the point of exit;
- (f) northbound or southbound flights which do not cross significant reporting lines shall report at the entry and exit points of the ACA; and
- (g) as requested by ATS.

12.7 CANADIAN TRACK STRUCTURES

12.7.1 ACA Track System

12.7.1.1 General

The ACA Track System consists of published tracks in the ACA serving international flights operating between Europe and Alaska/Orient. The routes are depicted on HI charts.

The ACA Track System is established to enhance the utilization of the airspace, and thus facilitate more efficient use of optimum flight levels and ATC separation minima. The use of named waypoints along the ACA Track System route will assist in the applications of data link technologies through automatic dependent surveillance (ADS) reporting and controller-pilot data link communications (CPDLC).

The ACA tracks are laterally separated throughout the Edmonton FIR and complement the fixed route system in the Anchorage FIR.

12.7.1.2 Flight Planning Procedures

The use of these tracks is not mandatory, but they have been published to facilitate flight planning.

If the flight is planned along the complete length of one of the ACA tracks, or a portion thereof, the track name shall be defined in Item 15 of the ICAO flight plan.

Examples:

- (a) LT M452 TAYTA
- (b) JESRU M451 PELRI
- (c) ADREW DCT TAVRI M452 LT

Flights may leave or join the ACA Track System routes in the Edmonton FIR at the identified waypoints. Random flight planning requirements in the ACA are specified in RAC 12.6.6.

12.7.1.3 Position Reports

Flights operating on ACA Track System routes shall report at designated compulsory reporting points, or as requested by ATS.

Abbreviated position reports are not permitted along the ACA Track System routes in the Edmonton FIR.

12.7.2 Northern Organized Track System

12.7.2.1 General

The Northern Organized Track System (NOR OTS) is a system of westbound tracks published daily to enhance the use of airspace for international flights operating between Europe and western North America. Aircraft operating in this airspace during hours of operation, as specified by NOTAM, should plan on using the NOR OTS. Aircraft not using the track system are expected to remain clear of the area, as specified in the flight planning section below. Priority will be given to aircraft on a track within the NOR OTS over an aircraft that is not.

12.7.2.2 Track Coordination and Publication

The NAV CANADA Traffic Management Unit (TMU) West produces the NOR OTS in consultation with operators. The timely receipt of the PRM is essential to this process. Criteria such as separation standards, optimum flight levels, wind prediction models and minimum flight time calculations must also be considered in the production of the NOR OTS.

PRMs are accepted by TMU West via the AFTN address CZVRTMUW until 1800 UTC daily (DST 1700 UTC). A proposed set of tracks are created and displayed on the NAV CANADA Web-based Traffic Density Analyser (TDA) at approximately 2030 UTC (DST 1930 UTC). This allows for collaborative decision-making and further analysis of the routes, if required. The tracks are published in a track definition message (TDM) and depicted on the TDA at approximately 2230 UTC (DST 2130 UTC).

The TDM is published in a national NOTAM file (CYHQ); it is also sent directly via AFTN to operators who have requested daily receipt of the information.

Stakeholders can request access to the TDA through NAV CANADA Customer Service by e-mail at <service@navcanada.ca>, or by telephone (toll-free) at 1-800-876-4693.

12.7.2.3 Flight Planning Procedures

Aircraft should flight plan along the complete length of one of the NOR tracks; however, aircraft entering the Edmonton FIR north of 76°N or south of 65°N may join the northernmost or southernmost NOR OTS track west of 80°W. Aircraft established on the northernmost or southernmost NOR OTS track may depart the track in a direction away from the NOR OTS.

Item 15 of the ICAO flight plan should include the full route description, as defined in the TDM. Each individual fix and waypoint corresponding to the flight-planned NOR route should be included.

The entry and exit fix to the NOR OTS track, as well as the actual NOR track number (e.g. NOR 1), can also be flight planned as an alternative to the full route description, provided the TMI cited in the current TDM is included in Item 18 of the ICAO flight plan.

Aircraft operating in the vicinity of the NOR OTS during hours of operation, as specified by NOTAM, and at published flight levels should flight plan as follows:

1. at least 60 NM from the outer edge of the NOR OTS while in CMNPS airspace,
2. at least 20 NM from the outer edge of the NOR OTS while in RNPC airspace; and/or
3. on NCA tracks and laterals when no NOR OTS is published—from 1300 to 2259 UTC (DST 1200 to 2159 UTC)—and when operating at FL290 to FL400.

Aircraft planning to cross the NOR OTS shall plan to do so at FL330 and below, or at FL400 and above. Westbound aircraft exiting the NOR OTS may flight plan direct to any fix associated with the North American Route Program (NRP) that is within one hour flying time from the NOR OTS exit point.

12.7.2.4 Position Reporting and Abbreviated Route Clearances Flights

Position Reporting and Abbreviated Route Clearances Flights operating on NOR routes shall report at designated waypoints or named fixes, as specified in the TDM.

ATC may issue an abbreviated route clearance to aircraft operating along a NOR OTS track. The abbreviated clearance will include the track designator rather than the detailed route description. The readback of an abbreviated route clearance must include the TMI number contained in the current TDM.

Example:

AIRLINER 123, EDMONTON CENTRE, CLEARED TO VANCOUVER INTERNATIONAL AIRPORT VIA CANAL NOR1 FORT MCMURRAY, J527 ENDERBY J508. MAINTAIN FLIGHT LEVEL 350, MACH DECIMAL EIGHT TWO.

Readback: (current TMI available):

EDMONTON CENTRE, AIRLINER 123 CLEARED TO VANCOUVER INTERNATIONAL AIRPORT VIA CANAL NOR1 FORT MCMURRAY, J527 ENDERBY J508 MAINTAIN FLIGHT LEVEL 350, MACH DECIMAL EIGHT TWO. TMI326.

If the current TMI is not available, a new clearance will be issued that includes a detailed route description. Flight crew operating on the NOR OTS should have the current NOR OTS TDM available to prevent this situation from occurring.

12.7.3 NCA Track System

12.7.3.1 General

The NCA Track System allows for a reduced lateral separation, and facilitates the application of the Mach number technique. The tracks are contained within the SCA and NCA, and extend upward from FL280. The system is primarily used by international flights operating between North America and Europe (NAT) and between North America and Alaska-Orient (PAC). The tracks are depicted on HI charts. The operating conditions for the two traffic flows are indicated in the following paragraphs.

12.7.3.2 Flight Planning Procedures

For flight planning an NCA or lateral track, the flight plan routing is indicated by using the abbreviation “NCA” or “LAT,” as appropriate, followed by the letter or number of the track.

Example:

- Track BRAVO: NCAB
- Lateral 3: LAT3
- Track 17: NCA17

12.7.3.3 Position Reports

For flights operating within the NCA Track System, position reports are to be indicated by the compulsory reporting point designator. In cases where these points have not been named, pilots should use the published coordinates for that point.

Example 1: For a flight on NCA Track BRAVO where it crosses 80°W: SIX SEVEN THREE ZERO NORTH, ZERO EIGHT ZERO WEST AT (time.)

Example 2: For a flight on NCA Track SIERRA where it crosses 90°W: SIGPI AT (time.)

12.7.3.4 NCA Tracks—NAT Traffic

There are no special conditions applicable to eastbound NAT traffic transiting CDA.

Although the use of the westbound NOR OTS is not mandatory, it should be noted that depending on the daily location of the NOR OTS, portions of the fixed route system that are not clear of the outer edge of the NOR OTS will not be available for flight planning purposes at the published flight levels and during the hours of operation, as specified by NOTAM. The affected NCA tracks and their associated laterals are listed in the remarks section of the AFTN TDM, the CYHQ NOTAM and the NAV CANADA TDA application.

NOTE: The requirement to flight plan and operate using the North American Route (NAR) System, as specified in the CFS, “Planning” section, remain in effect.

12.7.3.5 NCA Tracks—PAC Traffic

PAC traffic includes flights operating from North America to Alaska, the Orient and the Russian Far East. No special conditions apply as flight planning on NCA tracks is completely optional for PAC traffic.

12.7.4 SCA Track System

12.7.4.1 General

The SCA Track System is primarily used by international traffic operating between the mid-west and western United States and Europe via the NAT. The tracks are within the SCA and extend upwards from FL180. The tracks are depicted on HI charts.

12.7.4.2 Flight Planning Procedures

The SCA tracks are completely optional for flight planning. Entry or exit from the SCA tracks may be at designated reporting points or at the reporting points coincident with the longitudes 80°W and 90°W. Lateral transitions between tracks may be flight planned or requested between significant reporting points. For flight planning an SCA track, the route is indicated by using the abbreviation “SCA,” followed by the letter of the track.

Example:

- Track HOTEL: SCAH

12.7.4.3 Position Reports

Flights operating within the SCA Track System shall report over reporting lines coincident with the longitudes 80°W and 90°W, designated reporting points, or as requested by ATS.

12.7.5 NAR System

- The NAR System provides an interface between NAT oceanic and domestic airspaces. Operating conditions and description of the NAR are contained in RAC 11.3 and the CFS, “Planning” section.
- For a detailed description of the NAR System, refer to the CFS NORTH AMERICAN ROUTES (NARs) for NORTH ATLANTIC TRAFFIC. Section 7(a) outlines the requirements to flight plan and operate using the NAR system.

12.8 SECURITY CONTROL OF AIR TRAFFIC

12.8.1 General

- Pilots who will enter the ADIZ while in the ACA may forward the required estimated time and place of ADIZ entry as part of their 115°W longitude position report (CAR 602.145, which appears in RAC 3.9).
- Pilots who will enter or operate within the ADIZ while in the NCA, shall be governed by the requirements as set out in CAR 602.145.

12.8.2 ESCAT Plan

In Canadian airspace, the ESCAT Plan provides security control of civil and military air traffic to ensure effective use of airspace when the appropriate authority declares an air defence emergency or any situation involving aerial activities that threatens national security or vital Canadian interests. The Plan’s outline highlights responsibilities, procedures, and instructions for the security control of civil and military air traffic with respect to diversion, landing, grounding and dispersal. The ESCAT plan was developed in co-ordination with DND, Transport Canada, and NAV CANADA.

The Commander, Canadian North American Aerospace Defence Command (NORAD) Region (CANR), is responsible for testing and implementing the ESCAT Plan. When the ESCAT Plan is implemented or tested, the appropriate NAV CANADA ACCs (through ATS units), under the direction of the National Defence Command Centre (NDCC), will take actions to broadcast instructions through civil and military ATS units as necessary.

Testing

To ensure the effectiveness of communications during the implementation of the ESCAT Plan, periodic tests may be conducted without any prior notice.

The test message will be broadcast as follows:

“ATTENTION—THIS IS AN ESCAT TEST. I SAY AGAIN, THIS IS AN ESCAT TEST.”

As these tests are considered essential to national security, co-operation of all pilots and agencies is necessary.

Implementation

In an emergency situation, the appropriate NAV CANADA ACC (through their respective ATS units), under directions of the Commander, CANR, will broadcast the following message:

“ATTENTION ALL AIRCRAFT—AIR DEFENCE EMERGENCY—ALL AIRCRAFT WILL COMPLY WITH THE PROCEDURES FOR THE EMERGENCY SECURITY CONTROL OF AIR TRAFFIC. VFR TRAFFIC ON THIS FREQUENCY MUST LAND AT THE NEAREST SUITABLE AIRFIELD AND FILE AN IFR OR DVFR FLIGHT PLAN.”

In accordance with CAR 602.146(2), the pilot-in-command of an aircraft who is notified by an ATC unit of the implementation of the ESCAT Plan shall

- (a) before take-off, obtain approval for the flight from the appropriate ATC unit or FSS;
- (b) comply with any instruction to land or to change course or altitude that is received from the appropriate ATC unit or FSS; and
- (c) provide the appropriate ATC unit or FSS with position reports
 - (i) when operating within controlled airspace, as required pursuant to CAR 602.125; and
 - (ii) when operating outside controlled airspace, at least every 30 min.

ESCAT Plan Phases

The ESCAT Plan may be implemented in phases to facilitate a smooth transition from normal peacetime air traffic identification and control procedures to the more restrictive identification and control procedures that accompany the full implementation of the ESCAT Plan. When the ESCAT Plan has been implemented, the movement of civil and military aircraft is governed by the implementation of an Emergency Air Traffic Priority List (EATPL) and/or a Security Control Authorization (SCA).

There are two phases in the implementation process.

- Phase One: Requires all aircraft in designated areas to file IFR/DVFR flight plans in accordance with CARs 602.76(1) and (2), CAR 602.145, this Plan and the established procedures detailed in the CFS (GPH 205).
- Phase Two: The Commander, CANR, restricts aircraft movement within designated areas through the implementation of the EATPL and SCA process.

NOTE: EATPL and SCA approval request procedures will be promulgated by NOTAM.

ESCAT Zones

For the purpose of implementing the ESCAT Plan, Canadian airspace has been divided into seven zones. During implementation, one or more zones, or portions of zones, may be activated (see Figure 12.2).

Figure 12.2 – Map of ESCAT Zones

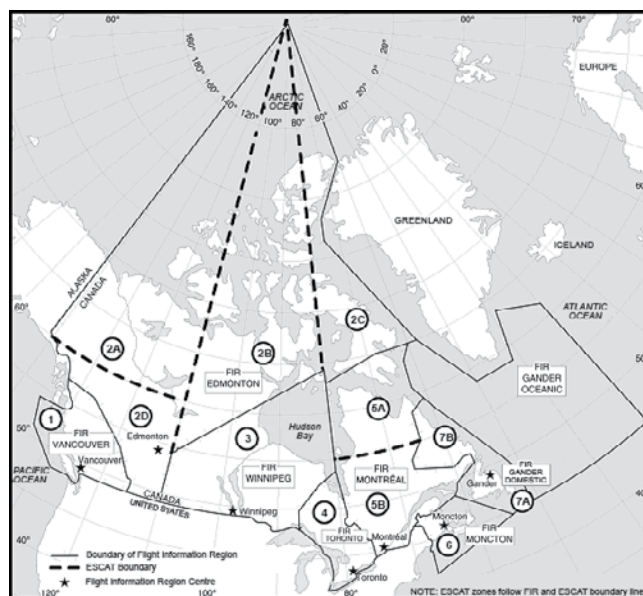

NOTE: Coordinates for the ESCAT Zones are published in the DAH (TP 1820).

Termination

Upon termination of ESCAT, the appropriate NAV CANADA ACC (through their respective ATS units) will broadcast the following message:

“ATTENTION ALL AIRCRAFT—EMERGENCY SECURITY CONTROL OF AIR TRAFFIC HAS BEEN TERMINATED. ROUTINE AIRSPACE PROCEDURES ARE NOW IN EFFECT.”

For more information about the ESCAT Plan, please contact the Transport Canada Civil Aviation Contingency Operations (CACO) Division at 1-877-992-6853 or 613-992-6853, or the NAV CANADA National Operations Centre at 613-248-4087.

12.9 AIR TRAFFIC FLOW MANAGEMENT (ATFM)

ATFM programs have been developed to ensure that national ATC systems are used to maximum capacity and that the need for excessive en-route airborne holding, especially at low altitude, is minimized. ATFM also distributes required delays more equitably among users. Initiatives include the publication of SID and STAR, the rerouting of aircraft because of sector overloading and weather avoidance, flow-control metering of arriving aircraft into TCAs, and the implementation of flow-control restrictions whereby aircraft are more economically held on the ground at departure airports to partially absorb calculated arrival delays at a destination airport.

Pilots or operators can obtain ATFM information, which may be pertinent for their particular flight, by referring to ATFM Advisories at <www.fly.faa.gov> or NOTAMs. Additional information, if required, can be obtained by contacting the shift manager or ATFM unit of the applicable ACC:

NAV CANADA	
National Operations Centre (Canada).....	1-866-651-9053
National Operations Centre (U.S.).....	1-866-651-9056
Gander ACC	709-651-5207
Moncton ACC	506-867-7173
Montréal ACC	514-633-3028 or 3365
Toronto ACC (Canada).....	1-800-268-4831
905-676-3528 or 4509	
Toronto ACC (U.S.).....	1-800-387-3801
Winnipeg ACC	204-983-8338
Edmonton ACC	780-890-4714
Vancouver ACC	604-775-9673 or 9622

12.10 FLOW CONTROL PROCEDURES

To minimize delays, air traffic management will use the least restrictive methods.

- (a) Altitude
- (b) Miles-in-trail/Minutes-in-trail
- (c) Speed control
- (d) Fix balancing
- (e) Airborne holding
- (f) Sequencing programs
 - (i) *Departure Sequencing Program (DSP)* DSP assigns a departure time to achieve a constant flow of traffic over a common point. Runway and departure procedures are considered for accurate projections.
 - (ii) *En route Sequencing Program (ESP)* ESP assigns a departure time that will facilitate integration into an en-route stream. Runway configuration and departure procedures will be considered for accurate projections.
 - (iii) *Arrival Sequencing Program (ASP)* ASP assigns meter fix times to aircraft destined to the same airport.
- (g) *Ground delay programs:* A ground delay program is an air traffic management process administered by the flow manager whereby aircraft are held on the ground. The purpose of the program is to support the air traffic management mission and limit airborne holding. It is a flexible program and may be implemented in various forms depending on the needs of the air traffic system. Ground delay programs provide for equitable assignment of delays to all system users.

- (h) *Ground stop:* The ground stop is a process whereby an immediate constraint can be placed on system demand. The constraint can be total or partial. The ground stop may be used when an area, centre, sector, or airport experiences a significant reduction in capacity. The reduced capacity may be the result of weather, runway closures, major component failures, or any other event that would render a facility unable to continue providing ATS.

This list is not inclusive and does not preclude the innovation and application of other procedures that result in improved customer service.

12.11 FUEL CONSERVATION HIGH LEVEL AIRSPACE

The following points are brought to the attention of pilots operating in the High Level Airspace, to ensure that each aircraft is operated as close as possible to its optimum flight level and Mach number.

- (a) Pilots should request a change of flight level or Mach number whenever this would improve the operating efficiency of the aircraft. However, in this regard, a request for a flight level not appropriate to the direction of flight will still be subject to the restrictions for use of altitudes inappropriate for direction of flight as detailed in RAC 7.6.2, Note 1.
- (b) Where possible pilots should give advance warning of a request (e.g., if a westbound flight wishes to climb at 30°W, it will assist the controller if the request is made with the position report at 20°W).
- (c) When circumstances render this feasible, controllers will ask other aircraft to accept higher flight levels or changes of Mach number in order to facilitate clearances for aircraft which would otherwise experience a significant penalty. In agreeing to such requests, pilots will contribute to the overall economy in fuel used.

12.12 ALTIMETER SETTING PROCEDURES DURING ABNORMALLY HIGH PRESSURE WEATHER CONDITIONS

12.12.1 General

Cold dry air masses can produce barometric pressures in excess of 31.00 inches of mercury. Because barometric readings of 31.00 inches of mercury or higher rarely occur, most standard altimeters do not permit the setting of barometric pressures above that level and are not calibrated to indicate accurate aircraft altitude above 31.00 inches of mercury. As a result, most altimeters cannot be set to provide accurate altitude readouts to the pilot in these situations.

RAC

ATC will issue actual altimeter settings and will confirm with the pilot that 31.00 inches of mercury is set on the pilot's altimeters for enroute operations below 18 000 feet ASL in the affected areas.

Aerodromes that are unable to accurately measure barometric pressures above 31.00 inches of mercury will report the barometric pressure as "in excess of 31.00 inches of mercury". Flight operations to and from those aerodromes are restricted to VFR weather conditions.

12.12.2 Flight Procedures

When the barometric pressure exceeds 31.00 inches of mercury, the following procedures take effect:

(a) Altimeters of all IFR, CVFR and VFR aircraft are to be set to 31.00 inches of mercury for enroute operations below 18 000 feet ASL. All pilots are to maintain this setting until beyond the area affected by the extreme high pressure or until reaching the final approach segment of an instrument approach for IFR aircraft or the final approach for VFR aircraft. At the beginning of the final approach segment, the current altimeter setting will be set by those aircraft capable of such a setting. Aircraft that are unable to set altimeter settings above 31.00 inches of mercury will retain a 31.00 inches of mercury setting throughout the entire approach. Aircraft on departure or missed approach will set 31.00 inches of mercury prior to reaching any mandatory or fix crossing altitude, or 1 500 feet AGL, whichever is lower.

(b) For aircraft operating IFR that are unable to set the current altimeter setting, the following restrictions apply:

(i) To determine the suitability of departure alternate aerodromes, destination aerodromes and destination alternate aerodromes, increase the ceiling requirements by 100 feet and visibility requirements by 1/4 SM for each 1/10 inch of mercury, or any portion thereof, over 31.00 inches of mercury. These adjusted values are then applied in accordance with the requirements of the applicable operating regulations and operations specifications.

Example:

Destination altimeter setting is 31.28 inches, ILS Decision Height (DH) is 250 feet (200-1/2). When flight planning, add 300-3/4 to the weather requirements, which would now become 500-11/4.

(ii) During the instrument approach, 31.00 inches of mercury will remain set. DH or Minimum Descent Altitude (MDA) will be deemed to have been reached when the published altitude is displayed on the altimeter.

NOTE: Although visibility is normally the limiting factor on an approach, pilots should be aware that when reaching DH, the aircraft will be higher than indicated by the altimeter, which in some cases could be as much as 300 feet higher.

(iii) Authorized CAT II and III ILS operations are not affected by the above restrictions.

(c) Night VFR pilots are advised that under conditions of altimeter settings above 31.00 inches of mercury and aircraft altimeters not capable of setting above 31.00 inches of mercury, the aircraft's true altitude will be higher than the indicated altitude; this must be taken into consideration. If an instrument approach procedure is to be flown, the night VFR pilot should follow the procedures described in RAC 12.12.2(b)(ii).

(d) For aircraft with the capability of setting the current altimeter setting and operating into aerodromes with the capability of measuring the current altimeter setting, no additional restrictions apply.

(e) For aircraft operating VFR, no additional restrictions apply; however, extra diligence in flight planning and in operating in these conditions is essential.

12.13 FORMATION FLIGHT PROCEDURES

12.13.1 General

Formation flight is considered to be more than one aircraft which, by prior arrangement between each of the pilots involved within the formation, operates as a single aircraft with regard to navigation and ATC procedures. Separation between aircraft within the formation is the responsibility of the flight leader and the pilots of the other aircraft within the formation. This includes transition periods when aircraft within the formation are manoeuvring to attain separation from each other to effect individual control, and during join-up and breakaway.

12.13.2 Formation Flight Planning Procedures

IFR and VFR flight planning procedures for formation flights are essentially the same as for a single aircraft with the following exceptions:

(a) a single flight plan may be filed for all aircraft within the formation;

(b) the flight lead will file an arrival report and close the flight plan for the formation;

(c) the Canadian flight plan/itinerary form is to be completed as follows:

(i) *Item 7, AIRCRAFT IDENTIFICATION*: indicate the formation call sign,

(ii) *Item 9, NUMBER AND TYPE OF AIRCRAFT AND WAKE TURBULENCE CATEGORY*: indicate the number of aircraft, followed by the type of aircraft designator or, in the case of formation flights comprising more than one type of aircraft, insert ZZZZ,

- (iii) *Item 10*, the letter “W” is not to be used for formation flights, regardless of the RVSM status of aircraft within the flight, and
 - (iv) *Item 18, OTHER INFORMATION*: if ZZZZ is included in Item 9, insert TYP/ followed by the number and type(s) of aircraft in the formation;
- (d) if the formation is to be non-standard, i.e. not in accordance with the parameters listed in RAC 12.13.3, the formation leader should insert the words “non standard” and should indicate the parameters to be used in the *OTHER INFORMATION* section of the Canadian flight plan/itinerary form.

12.13.3 IFR and CVFR Formation Flight

ATC will clear a formation flight as if it is a single aircraft. Additional airspace will not be protected unless the requirement to do so is included on the flight plan and has been previously co-ordinated. It is the formation leader’s responsibility to flight plan for extra airspace and to co-ordinate with ATC if the formation will not operate in accordance with the following IFR and CVFR formation flight criteria:

- (a) the formation leader will operate at the assigned altitude, and the other formation aircraft will be within 100 ft vertically of the altitude of the formation leader;
- (b) the formation will occupy a maximum frontal width of 1 NM; and
- (c) the formation will have a maximum longitudinal spacing of 1 NM between the first and the last aircraft.

The formation leader is responsible for separation between aircraft within the formation and for ensuring that all the formation aircraft remain within these parameters unless additional airspace has been allocated. Although IFR formation flights are expected to take off and land in formation, unforeseen conditions may preclude the formation from completing an IFR approach and landing. If it becomes necessary for a formation to break into individual elements or single aircraft, the formation leader should advise the controlling agency of the destination as soon as possible to allow ATC sufficient time to assign flight levels or altitudes that will provide vertical separation for each element or aircraft. In such instances, the formation leader will retain responsibility for separation between elements or aircraft until all have reached the assigned flight levels or altitudes.

All formation flights will be considered as non-certified RVSM flights, regardless of the RVSM certification status of the individual aircraft within the formation.

12.14 PHOTOGRAPHIC SURVEY FLIGHTS

CAR 602.34 – *Cruising Altitudes and Cruising Flight Levels*, exempts aircraft operated for the purpose of aerial survey or mapping from the cruising altitude for direction of flight requirement if certain conditions are met.

Subject to RAC 12.16.6 (d), photographic survey flights are exempt from the requirement to be RVSM certified to operate in RVSM airspace to conduct aerial survey or mapping operations. This exemption is not applicable for that portion of flight transiting to/from the area of operation.

Pilots intending to conduct aerial survey or mapping operations should refer to CAR 602.34 and obtain the publication, *Pilot Procedures Photographic Survey Flights* from:

NAV CANADA
Manager, ATS Standards and Procedures
77 Metcalfe Street
Ottawa ON K1P 5L6

Tel.: 613-563-5659

This publication describes flight requirements for pilots and operators conducting survey operations in Canadian airspace. It is published so that the ATC system can better accommodate the special demands and the unique operational requirements of aircraft on photographic survey missions.

12.15 SAFETY ALERT PROCEDURE AND PHRASEOLOGY

12.15.1 General

A Safety Alert is a notification by an air traffic controller to an aircraft that it is in a position which, in the controller’s judgment, is in unsafe proximity to terrain, obstructions or other aircraft. Low altitude alerts are issued for unsafe proximity to terrain or obstructions, while traffic alerts are issued for unsafe proximity to other aircraft.

Once the aircraft is informed of the Safety Alert, it is the pilot’s responsibility to determine what course of action, if any, will be taken.

12.15.2 Controller Phraseology

SCENARIO	SAMPLE PHRASEOLOGY
Controller becomes aware that an aircraft is at an altitude that is in unsafe proximity to terrain or an obstruction.	FBAC, LOW ALTITUDE ALERT. VERIFY YOUR ALTITUDE IMMEDIATELY. CYEG ALTIMETER IS 2992. THE MINIMUM IFR ALTITUDE IS FOUR THOUSAND.
Controller becomes aware that an aircraft is in unsafe proximity to another aircraft.	FBAC, TRAFFIC ALERT UNIDENTIFIED TRAFFIC TWO O'CLOCK SIX MILES, WESTBOUND, ALTITUDE EIGHT THOUSAND UNVERIFIED.

12.15.3 ATC Conflict Alert Software

ATC Conflict Alert Software is intended to alert controllers of situations where separation could be compromised. The display of this alert would normally occur approximately one min prior to a loss of separation and one min prior to the display of a TCAS RA. Warning time can be shorter depending on factors such as flight path configuration; however, in most instances, sufficient time should exist for conflict resolution prior to the display of a TCAS RA.

Once the ATC alert is validated and it is determined that the situation requires corrective action, the controller must use imperative phraseology as specified in RAC 12.15.4.

12.15.4 Use of the Terms Traffic Alert and Airspace Alert as Part of an Avoidance Instruction

The terms “traffic alert” and “airspace alert” used in conjunction with an avoidance instruction require pilot compliance and acknowledgement. However, Safety Alert instructions do not supersede existing pilot requirements to follow TCAS/ACAS RAs.

12.15.5 Controller Phraseology

SCENARIO	SAMPLE PHRASEOLOGY
Controller responds to an ATC conflict alert advisory or to an observed loss or imminent loss of separation between identified aircraft in controlled airspace.	FABC, TRAFFIC ALERT TURN LEFT 30 DEGREES IMMEDIATELY. -or- FABC, TRAFFIC ALERT CLIMB TO 4 THOUSAND IMMEDIATELY.
Controller issues corrective action in response to a loss or an imminent loss of separation within Class F airspace.	FABC, AIRSPACE ALERT CLIMB TO FL330 IMMEDIATELY TO AVOID RESTRICTED AIRSPACE. -or- FABC, AIRSPACE ALERT TURN RIGHT 60 DEGREES IMMEDIATELY TO AVOID RESTRICTED AIRSPACE.

12.16 TRAFFIC ALERT AND COLLISION AVOIDANCE SYSTEMS AND AIRBORNE COLLISION AVOIDANCE SYSTEMS

12.16.1 General

TCAS is the acronym for the Traffic Alert and Collision Avoidance System developed in the United States by the Federal Aviation Administration (FAA), while the Airborne Collision Avoidance System (ACAS) is the name applied by the International Civil Aviation Organization (ICAO) for similar systems.

TCAS/ACAS is designed to operate independently of ATC and, depending on the type of TCAS/ACAS, will display proximate traffic, providing Traffic Alerts (TAs) and Resolution Advisories (RAs). TAs provide information on proximate traffic and are intended to assist the flight crew in visual acquisition of conflicting traffic and to alert pilots to the possibility of an RA. RAs are divided into two categories: preventative advisories, which instruct the pilot to maintain or avoid certain vertical speeds; and corrective advisories, which instruct the pilot to deviate from the current flight path (e.g., “CLIMB” when the aircraft is in level flight). In an encounter between two TCAS/ ACAS II equipped aircraft, their computers will communicate using the Mode S transponder data link which has the capability to provide complementary RAs (e.g., one climbing and one descending). Aircraft without transponders are invisible to TCAS/ACAS equipped aircraft; thus, TAs or RAs are not provided.

There are three types of TCAS/ACAS:

- (a) *TCAS/ACAS I* is a less sophisticated system which will provide a warning of proximate traffic (TA) without guidance to avoid potential collisions;
- (b) *TCAS/ACAS II* consists of a computer, pilot displays, a Mode S transponder, modified instantaneous vertical speed indicators, controls, wiring and antennas which provide both TAs and vertical plane RAs;
- (c) *TCAS/ACAS IV* is a more advanced system (still under development) which will provide TAs, and both horizontal and vertical plane RAs, i.e., turns, as well as climbs and descents.

12.16.2 Use of TCAS/ACAS

The United States is the only state in the world which mandates the use of TCAS/ACAS. The following TCAS/ACAS requirements must be complied with in order to operate in U.S. airspace:

- (a) *TCAS/ACAS I*: All aircraft with 10 to 30 passenger seats were required to be equipped with TCAS/ACAS I by December 31, 1995.
- (b) *TCAS/ACAS II*: All aircraft with more than 30 passenger

seats were required to be equipped with TCAS/ACAS II by December 30, 1993. Since its development, TCAS/ACAS has undergone a number of modifications, particularly the computer logic. The latest logic version, 6.04A, required installation by December 30, 1994.

12.16.3 Transport Canada TCAS/ACAS Policy

While Transport Canada encourages the installation of TCAS/ACAS, the equipment will not be made mandatory in Canadian airspace for the foreseeable future. Notwithstanding, Canadian operators must obtain airworthiness and operational approval from Transport Canada before TCAS/ACAS is operated in Canadian airspace. Foreign operators must comply with the requirements of FAA Advisory Circulars AC120-55A (as amended); AC20-131A (as amended); and FAA Technical Standard Order (TSO) C119A.

12.16.4 Operational Approval

For Canadian operators, TCAS/ACAS II operational approval is accomplished through Transport Canada approval of pertinent training programs, checklists, operations manuals or training manuals, maintenance programs, minimum equipment lists or other pertinent documents or document revisions applicable to that operator. The appropriate Transport Canada offices review the proposed programs and documents, and respond by letter, manual approval, checklist approval, or other pertinent action, when each necessary issue is suitably addressed.

Canadian operators should make early contact with Transport Canada on specific program proposals to permit a timely response. Usually, such a contact is initiated at the time preparations are being made for TCAS/ACAS selection or purchase, and generally not later than type certificate or supplemental type certificate application.

In order for Canadian operators to meet the regulatory requirements, they must address the following training, checking, and currency issues for TCAS/ACAS flight crew qualification:

- (a) initial ground training;
- (b) initial flight training (except for those programs which do not require flight training, as permitted by FAA Advisory Circular AC120-55A, as amended);
- (c) initial checking;
- (d) recurrent training;
- (e) recurrent checking; and
- (f) currency.

Canadian operators may address these issues individually or as part of an integrated program. For example, TCAS/ACAS qualification may be keyed to qualification of specific aircraft (e.g., during A320 transition), may be addressed in conjunction with general flight crew qualification (e.g., during initial new hire indoctrination), or may be completed as dedicated TCAS/ACAS training and checking (e.g., by completion of a standardized TCAS/ACAS curriculum in conjunction with a recurrent IFT/PPC event).

Transport Canada requires the same standards as those specified in FAA Advisory Circular AC120-55A, as amended. Therefore, operators should refer to this advisory circular for the details needed to obtain approval of training programs.

12.16.5 Airworthiness Approval

An acceptable means of demonstrating compliance with the appropriate requirements of the *Airworthiness Manual*, Chapter 525, to obtain airworthiness approval, is to follow the method specified in FAA Advisory Circular AC 20-131A—*Airworthiness Approval of Traffic Alert and Collision Avoidance Systems (TCAS II) and Mode S Transponders* (as amended).

Canadian operators who require TCAS/ACAS installation to fly into U.S. airspace should apply for approval, in accordance with FAA AC20-131A (as amended), from their Transport Canada regional office. Once a Transport Canada supplemental type certificate is granted, Transport Canada will apply on behalf of the applicant to the FAA for a supplemental type certificate under the bilateral aviation safety agreement.

NOTE: All installed equipment shall be certified to the Technical Standard Order (TSO) C119A, *Traffic Alert and Collision Avoidance System (TCAS) Airborne Equipment, TCAS II*.

12.16.6 Pilot Immunity from Enforcement Action for Deviating from Clearances

In accordance with CAR 602.31, pilots are permitted to deviate from a clearance in order to follow a resolution advisory in Canadian airspace. After responding to the resolution advisory, the pilot shall, as soon as possible, advise ATC of the deviation, and return to the altitude in the previous clearance, or obtain another one. The policy outlined below is the same as applies in U.S. airspace.

The Transport Canada policy for Canadian airspace with respect to enforcement investigation into a deviation from an assigned altitude in response to a TCAS/ACAS RA, and the use of TCAS/ACAS recorded data is as follows:

The use of TCAS/ACAS II may result in a flight crew deviating from an assigned altitude for a short period of time. During the investigation of the incident, all factors will be considered, including factors that are TCAS/ACAS related, before a final determination is made. Specifically, enforcement action will not be taken against flight crew

who deviate from a clearance issued by ATC when that deviation is in response to a TCAS/ACAS generated RA and the response is in accordance with the operator's approved flight procedures. Likewise, enforcement action will not be taken if the operator's procedures allow a crew not to follow a displayed RA because of other information that may be available to the pilot.

12.16.7 Mode S Transponder Approval and Unique Codes

Along with performing all the functions of Mode A and C transponders, Mode S transponders also have a data link capability. Mode S transponders are an integral component of all TCAS/ACAS II installations.

There is no requirement to replace existing Mode A or C transponders with Mode S transponders until it becomes impossible to maintain presently installed Mode A and C transponders.

Airworthiness approval must be obtained by Canadian aircraft operators who install Mode S transponders. FAA Advisory Circular AC20-131A (as amended) should be used for guidance to obtain airworthiness approval. Canadian operators should contact their Regional Transport Canada office for approval details. Each Canadian registered aircraft with a Mode S transponder must receive a unique Code assignment, which must be loaded in the transponder, through their Transport Canada Regional Superintendent of Personnel and Aircraft Licensing.

12.16.8 Pilot/Controller Actions

In order to use TCAS/ACAS in the most effective and safest manner, the following pilot and controller actions are necessary:

- (a) Pilots should not manoeuvre their aircraft in response to TAs only;
- (b) Pilots should notify the appropriate ATC unit, as soon as possible, of the deviation, including its direction, and when the deviation has ended;
- (c) In the event of an RA to alter the flight path, the alteration of the flight path should be limited to the minimum extent necessary to comply with the RA;
- (d) When a pilot reports a manoeuvre induced by an RA, the controller should not attempt to modify the aircraft flight path until the pilot reports returning to the terms of the existing ATC instruction or clearance, but should provide traffic information as appropriate;
- (e) Pilots who deviate from an ATC instruction or clearance in response to an RA shall promptly return to the terms of that instruction or clearance when the conflict is resolved.

12.16.9 Pilot and Controller Phraseology

ICAO is currently developing pilot/controller phraseologies. It should be noted that, for the purpose of phonetic clarity, the term TCAS is used.

CIRCUMSTANCES	PHRASEOLOGIES
After modifying vertical speed to comply with a TCAS/ACAS RA	Pilot: (call sign) TCAS RA; Controller: (acknowledgement);
After TCAS/ACAS "Clear of conflict" is announced in the cockpit	Pilot: (call sign) CLEAR OF CONFLICT, RETURNING TO ASSIGNED ALTITUDE; Controller: (acknowledgement) (or alternate instructions);
After returning to clearance after responding to a TCAS/ACAS RA	Pilot: (call sign) CLEAR OF CONFLICT, (assigned altitude) RESUMED; Controller: (acknowledgement) (or alternate instructions);
When unable to comply with a clearance because of a TCAS/ACAS RA	Pilot: (call sign) UNABLE TO COMPLY, TCAS RA; Controller: ROGER.

12.16.10 Recommended Use

The use of equipment such as TCAS/ACAS and transponders complements each other and contributes to the safety of air operations. Therefore, it is recommended that pilots operating aircraft with either or both ensure that the equipment is always turned on and functioning, despite the class of airspace within which they may be operating.

12.17 REDUCED VERTICAL SEPERATION MINIMUM (RVSM)

12.17.1 Definitions

RVSM: The application of 1000-ft vertical separation at and above FL 290 between aircraft approved to operate in reduced vertical separation minimum airspace.

Non-RVSM Aircraft: An aircraft that does not meet reduced vertical separation minimum (RVSM) requirements for certification and/or for operator approval.

RVSM Aircraft: An aircraft that meets reduced vertical separation minimum (RVSM) requirements for certification and for operator approval.

12.17.2 RVSM Airspace

- (a) RVSM airspace is all airspace within CDA from FL290 to FL410 inclusive as defined in the DAH (TP 1820) and depicted in Figure 12.3.

Figure 12.3 – RVSM Airspace and RVSM Transition Airspace

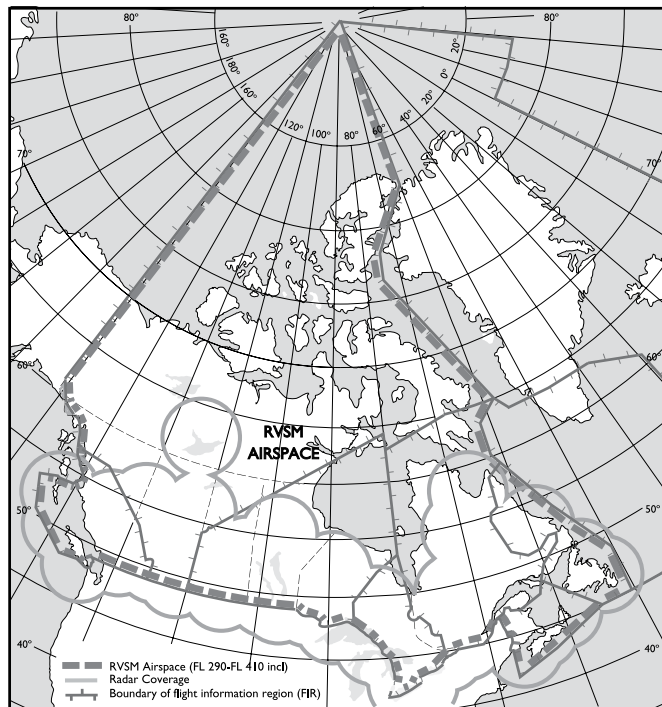

12.17.3 ATC Procedures

- (a) Within RVSM airspace ATC:
 - (i) will, within non-radar airspace, endeavour to establish 2 000 ft separation or applicable lateral or longitudinal separation minimum if an aircraft reports greater-than-moderate turbulence, and/or mountain wave activity that is of sufficient magnitude to significantly affect altitude-keeping, and is within 5 min of another aircraft at 1 000 ft separation;
 - (ii) will, within radar airspace, vector aircraft to establish radar separation or establish 2 000 ft separation if an aircraft reports greater-than-moderate turbulence, or encountering mountain wave activity that is of sufficient magnitude to significantly affect altitude-keeping, if 1 000 ft vertical separation exists between two aircraft, and targets appear likely to merge;
 - (iii) may structure portions of the airspace for specific periods of time for one-way traffic in which inappropriate flight levels to the direction of flight may be assigned; and
 - (iv) may, within non-radar airspace, temporarily suspend RVSM within selected areas and/or altitudes due to adverse weather conditions, e.g. pilot reports greater-than-moderate turbulence. When RVSM is suspended, the vertical separation minimum between all aircraft will be 2 000 ft.

- (b) Pilots may be requested by ATC to confirm that they are approved for RVSM operations. Pilots/operators unable to provide such confirmation will be issued a clearance to operate outside RVSM airspace:

Phraseology: *"Affirm RVSM" or "Negative RVSM (supplementary information, e.g. monitoring flight)."*
See phraseology depicted in Figure 12.4

12.17.4 In-Flight Procedures

- (a) Before entering RVSM airspace, the status of required equipment should be reviewed. The following equipment should be operating normally:
 - (i) two independent altitude measurement systems;
 - (ii) one automatic altitude control system; and
 - (iii) one altitude alert system.
- (b) The pilot must notify ATC whenever the aircraft:
 - (i) is no longer RVSM-compliant due to equipment failure;
 - (ii) experiences loss of redundancy of altimetry systems; or
 - (iii) encounters turbulence or mountain wave activity that affects the capability to maintain the cleared flight level.
- (c) In the event that any of the required equipment fails prior to entering RVSM airspace, a new clearance should be requested in order to avoid RVSM airspace.
- (d) In level cruise, it is essential that the aircraft maintains the cleared flight level. Except in contingency situations, aircraft should not deviate from the cleared flight level without an ATC clearance. If the pilot is notified by ATC of an assigned altitude deviation (AAD) error of 300 ft or greater, the pilot should return to the cleared flight level as soon as possible.
- (e) TRANSITION BETWEEN FLs: During cleared transition between flight levels, the aircraft should not overshoot or undershoot the assigned level by more than 150 ft.

12.17.5 Flight Planning Requirements

- (a) Unless an aircraft can be accommodated in RVSM airspace as detailed in paragraph 12.17.6, RVSM approval is required for the aircraft to operate within RVSM airspace. The operator must determine that the aircraft has been approved by the appropriate State authority and will meet the RVSM requirements for the filed route of flight and any planned alternate routes. The letter "W" shall be inserted in Item 10 (Equipment) of the flight plan to indicate that the aircraft is RVSM-compliant and the operator is RVSM-approved. The "W" designator is not to be used unless both conditions are met. If the aircraft registration is not used in Item 7, the registration is to be entered in Item 18 (RAC 3.16.8 "REG/").

RAC

- (b) ATC will use the equipment block information to either issue or deny clearance into RVSM airspace and to apply either 1 000 ft or 2 000 ft vertical separation minimum.
- (c) Non-RVSM aircraft requesting permission to operate in RVSM airspace shall include “STS/NONRVSM” in item 18 of the flight plan to indicate the reason for special handling by ATS.

12.17.6 Operation of Non-RVSM Aircraft in RVSM Airspace

- (a) **FLIGHT PRIORITY:** RVSM aircraft will be given priority for level allocation over non-RVSM aircraft. Non-RVSM aircraft may be accommodated on a traffic- and workload-permitting basis.
- (b) **VERTICAL SEPARATION:** The vertical separation minimum between non-RVSM aircraft operating in RVSM airspace and all other aircraft is 2 000 ft.
- (c) **CONTINUOUS CLIMB OR DESCENT THROUGH RVSM AIRSPACE:** Non-RVSM aircraft may be cleared to climb to and operate above FL 410 or descend to and operate below FL 290, provided the aircraft is capable of:
 - (i) a continuous climb or descent and does not need to level off at an intermediate altitude for any operational considerations; and
 - (ii) climb or descent at the normal rate for the aircraft.
- (d) **STATE AIRCRAFT:**

For the purposes of RVSM operations, State aircraft are those aircraft used in military, customs and police services.

State aircraft are exempt from the requirement to be RVSM-approved to operate in RVSM airspace.

- (e) **NON-RVSM AIRCRAFT IN RVSM AIRSPACE:**

Non-RVSM aircraft may flight plan to operate within RVSM airspace, provided the aircraft:

- (i) is being delivered to the State of Registry or Operator;
- (ii) was formerly RVSM-approved, but has experienced an equipment failure and is being flown to a maintenance facility for repair in order to meet RVSM requirements and/or obtain approval;
- (iii) is being utilized for mercy or humanitarian purposes;
- (iv) is a photographic survey flight (CDA only). This approval is not applicable for that portion of flight transiting to and from the area(s) of surveying or mapping operations;
- (v) is conducting flight checks of a NAVAID. This approval is not applicable for that portion of flight transiting to and from the area(s) of flight check operations; or
- (vi) is conducting a monitoring, certification or developmental flight.

- (f) **PHRASEOLOGY:**

Pilots of non-RVSM flights should include the phraseology “negative RVSM” in all initial calls on ATC frequencies, requests for flight level changes, readbacks of flight level clearances within RVSM airspace and readbacks of climb or descent clearances through RVSM airspace. See Figure 12.4.

12.17.7 Delivery Flights for Aircraft that are RVSM-Compliant on Delivery

- (a) An aircraft that is RVSM-compliant on delivery may operate in Canadian Domestic RVSM airspace provided that the crew is trained on RVSM policies and procedures applicable in the airspace and the responsible State issues the operator a letter of authorization approving the operation.
- (b) State notification to the NAARMO (see RAC 12.16.10) should be in the form of a letter, e-mail or fax documenting the one-time flight indicating:
 - (i) planned date of the flight;
 - (ii) flight identification;
 - (iii) registration number; and
 - (iv) aircraft type/series.

12.17.8 Airworthiness and Operational Approval and Monitoring

- (a) Operators must obtain airworthiness and operational approval from the State of Registry or State of the Operator, as appropriate, to conduct RVSM operations. For the purposes of RVSM, the following terminology has been adopted:
 - (i) *RVSM Airworthiness Approval:* The approval that is issued by the appropriate State authority to indicate that an aircraft has been modified in accordance with the relevant approval documentation, e.g. service bulletin, supplemental type certificate, and is therefore eligible for monitoring. The date of issue of such an approval should coincide with the date when the modification was certified by the operator as being complete.
 - (ii) *RVSM (Operational) Approval:* The approval that is issued by the appropriate State authority once an operator has achieved the following:
 - (A) RVSM airworthiness approval; and
 - (B) State approval of Operations Manual (where applicable) and on-going maintenance procedures.
- (b) Operators of Canadian-registered aircraft intending to operate in RVSM airspace will be required to show that they meet all the applicable standards in accordance with CARs Parts VI and VII. Information on RVSM approval may be obtained from:

Airworthiness Approvals:

Transport Canada
Safety and Security Director,
Aircraft Certification (AARD)
Ottawa ON K1A 0N8

Fax: 613-996-9178

ARINC
Annapolis, MD
RVSM Operations Coordinator
Tel: 410-266-4707
E-mail: rvsmops@arinc.com
Web site: <www.arinc.com/products/rvsm/>

Operating Standards Commercial Air Carriers and Private Operators:

Transport Canada
Safety and Security Director,
Commercial and Business Aviation (AARX)
Ottawa ON K1A 0N8

Fax: 613-954-1602

RVSM Maintenance Programs:

Transport Canada
Safety and Security Director,
Aircraft Maintenance and Manufacturing (AARP)
Ottawa ON K1A 0N8

Fax: 613-996-9178

12.17.10 NAARMO

(a) The Regional Monitoring Agency for CDA is the NAARMO, located in Atlantic City, NJ, and may be contacted as follows:

William J. Hughes Technical Center
NAS & International Airspace Analysis Branch (ACT-520)
Atlantic City International Airport
Atlantic City, NJ 08405 USA

Fax: 609-485-5117
AFTN: N/A

(b) Information on the responsibilities and procedures applicable to the NAARMO may be found on the Web site: <www.tc.faa.gov/act-500/niaab/rvsm/naarmo_intro.asp>.

12.17.9 Monitoring

(a) All operators that operate or intend to operate in airspace where RVSM is applied are required to participate in the RVSM monitoring program. Monitoring prior to the issuance of RVSM operational approval is not a requirement. However, operators should submit monitoring plans to the responsible civil aviation authority to show that they intend to meet the North American RVSM Minimum Monitoring Requirements.

(b) Ground-based and GPS-based monitoring systems are available to support RVSM operations. Monitoring is a quality control program that enables Transport Canada and other civil aviation authorities to assess the in-service altitude-keeping performance of aircraft and operators.

(c) Ground-based height monitoring systems are located in the vicinity of Ottawa, Ont., and Lethbridge, Alta. Over-flight of ground-based height monitoring systems is transparent to the pilot. Aircraft height-keeping performance monitoring flights using ground-based monitoring systems should be flight planned to route within a 30 NM radius of the Ottawa VORTAC, or a 30 NM radius of the Lethbridge VOR/DME.

(d) GPS monitoring unit (GMU) services to conduct a height-keeping performance monitoring flight may be obtained from the following agencies:

CSSI, Inc.
Washington, DC
Tel: 202-863-2175
E-mail: monitor@cssiinc.com
Web site: <www.rvsm-monitoring.com>

12.17.11 ACAS II

It is recommended that those aircraft equipped with ACAS and operated in RVSM airspace be equipped with ACAS II (TCAS II systems with Version 7.0 incorporated meets the ICAO ACAS II standards).

12.17.12 Mountain Wave Activity (MWA)

(a) Significant MWA occurs both below and above FL290, which is the floor of RVSM airspace. It often occurs in western Canada and western USA in the vicinity of mountain ranges. It may occur when strong winds blow perpendicular to mountain ranges, resulting in up and down or wave motions in the atmosphere. Wave action can produce altitude excursions and airspeed fluctuations accompanied by only light turbulence. With sufficient amplitude, however, wave action can induce altitude and airspeed fluctuations accompanied by severe turbulence. MWA is difficult to forecast and can be highly localized and short-lived.

(b) Wave activity is not necessarily limited to the vicinity of mountain ranges. Pilots experiencing wave activity anywhere that significantly affects altitude-keeping can follow the guidance provided below.

(c) In-flight indications that the aircraft is being subjected to MWA are:

- (i) altitude excursions and airspeed fluctuations with or without associated turbulence;
- (ii) pitch and trim changes required to maintain altitude with accompanying airspeed fluctuations; and
- (iii) light to severe turbulence depending on the magnitude of the MWA

- (d) *TCAS Sensitivity*—For both MWA and greater-than-moderate turbulence encounters in RVSM airspace, an additional concern is the sensitivity of collision avoidance systems when one or both aircraft operating in close proximity receive TCAS advisories in response to disruptions in altitude hold capability.
- (e) *Pre-flight tools*—Sources of observed and forecast information that can help the pilot ascertain the possibility of MWA or severe turbulence are: Forecast Winds and Temperatures Aloft (FD), Area Forecast (FA), SIGMETs and PIREPS.

12.17.13 Wake Turbulence

- (a) Pilots should be aware of the potential for wake turbulence encounters following Southern Domestic RVSM (SDRVSM) implementation. Experience gained since 1997, however, has shown that such encounters in RVSM airspace are generally moderate or less in magnitude.
- (b) It is anticipated that, in SDRVSM airspace, wake turbulence experience will mirror European RVSM experience gained since January 2002. European authorities have found that reports of wake turbulence encounters had not increased significantly since RVSM implementation (eight versus seven reports in a ten-month period). In addition, they found that reported wake turbulence was generally similar to moderate clear air turbulence.
- (c) Pilots should be alert for wake turbulence when operating:
 - (i) in the vicinity of aircraft climbing or descending through their altitude;
 - (ii) approximately 12–15 mi. after passing 1 000 ft below opposite direction traffic; and
 - (iii) approximately 12–15 mi. behind and 1 000 ft below same direction traffic.

Figure 12.4 – Pilot/Controller Phraseology—RVSM Operations Standard Phraseology for RVSM Operations

Message	Phraseology
For a controller to ascertain the RVSM approval status of an aircraft	(call sign) confirm RVSM approved
Pilot indication that flight is RVSM-approved	Affirm RVSM
Pilot will report lack of RVSM approval (Non-RVSM status): a. On the initial call on any frequency in the RVSM airspace; and b. In all requests for flight level changes pertaining to flight levels within the RVSM airspace; and c. In all read-backs to flight level clearances pertaining to flight levels within the RVSM airspace; and d. In read-back of flight level clearances involving climb and descent through RVSM airspace (FL290-410)	Negative RVSM (supplementary information, e.g. "monitoring flight")
Pilot report of one of the following after entry into RVSM airspace: all primary altimeters, automatic altitude control systems or altitude alerters have failed (This phrase is to be used to convey both the initial indication of RVSM aircraft system failure and on initial contact on all frequencies in RVSM airspace until the problem ceases to exist or the aircraft has exited RVSM airspace)	Unable RVSM Due Equipment
ATC denial of clearance into RVSM airspace	Unable issue clearance into RVSM airspace, maintain FL___.
Pilot reporting inability to maintain cleared flight level due to weather encounters. See RAC 12.16.12(c)	Unable RVSM due (state reason) (e.g. turbulence, mountain wave)
ATC requesting pilot to confirm that an aircraft has regained RVSM-approved status or a pilot is ready to resume RVSM	Confirm able to resume RVSM
Pilot ready to resume RVSM after aircraft system or weather contingency	Ready to resume RVSM

12.17.14 In-Flight Contingencies

(a) The following general procedures are intended as guidance only. Although all possible contingencies cannot be covered, they provide for cases of inability to maintain assigned level due to:

- (i) weather;
- (ii) aircraft performance; and
- (iii) pressurization failure.

The pilot's judgment should determine the sequence of actions to be taken, taking into account specific circumstances, and ATC shall render all possible assistance.

(b) If an aircraft is unable to continue flight in accordance with its ATC clearance, a revised clearance shall, whenever possible, be obtained prior to initiating any action, using a distress or urgency signal if appropriate. If prior clearance cannot be obtained, an ATC clearance shall be obtained at the earliest possible time. The pilot should take the following actions until a revised ATC clearance is received:

- (i) establish communications with and alert nearby aircraft by broadcasting, at suitable intervals: flight identification, flight level, aircraft position, (including the ATS route designator or the track code) and intentions on the frequency in use, as well as on frequency 121.5 MHz (or, as a back-up, the inter-pilot air-to-air frequency 123.45 MHz);
- (ii) initiate such action as necessary to ensure safety. If the pilot determines that there is another aircraft at or near the same flight level, which might conflict, the pilot is expected to adjust the path of the aircraft, as necessary, to avoid conflict.

Figure 12.5 provides pilot guidance on actions to take under certain conditions of aircraft system failure and weather encounters. It also describes the ATC controller actions in these situations. It is recognized that the pilot and controller will use judgement to determine the action most appropriate to any given situation.

Figure 12.5 – Contingency Actions: Weather Encounters and Aircraft System Failures

Initial Pilot Actions in Contingency Situations

- Initial pilot actions when unable to maintain flight level or unsure of aircraft altitude-keeping capability
- Notify ATC and request assistance as detailed below;
 - Maintain cleared flight level, if possible, while evaluating the situation;
 - Watch for conflicting traffic, both visually and with reference to ACAS/TCAS, if equipped; and
 - Alert nearby aircraft by illuminating exterior lights, broadcasting position, flight level and intentions on 121.5 MHz (or as back-up, the inter-pilot air-to-air frequency, 123.45 MHz).

Inability to Maintain Cleared Flight Level Due to Weather Encounter

Pilot should:	ATC may be expected to:
<ul style="list-style-type: none"> • Contact ATC and advise • Unable RVSM Due (state reason)" (e.g. turbulence, mountain wave) 	<ul style="list-style-type: none"> • In radar airspace, where 1 000 ft vertical separation exists between two aircraft, and targets appear likely to merge, vector one or both aircraft to establish radar separation until the pilot reports clear of the turbulence
<ul style="list-style-type: none"> • If not initiated by the controller, and if in radar airspace, request vector clear of traffic at adjacent flight levels 	<ul style="list-style-type: none"> • Provide lateral or longitudinal separation from traffic at adjacent flight levels, traffic-permitting
<ul style="list-style-type: none"> • Request flight level change or re-route, if desired 	<ul style="list-style-type: none"> • Advise pilot of conflicting traffic
	<ul style="list-style-type: none"> • Issue flight level change or re-route, traffic-permitting

Pilot Report of Mountain Wave Activity (MWA)

Pilot should:	ATC may be expected to:
<ul style="list-style-type: none"> • Contact ATC and report experiencing MWA 	<ul style="list-style-type: none"> • Advise pilot of conflicting traffic
<ul style="list-style-type: none"> • If advised of conflicting traffic at adjacent flight levels and the aircraft is experiencing MWA that significantly affects altitude-keeping, request vector to acquire horizontal separation • If so desired, request a flight level change or re-route 	<ul style="list-style-type: none"> • If pilot requests, vector aircraft to achieve horizontal separation, traffic-permitting • In radar airspace, where 1 000 ft vertical separation exists between two aircraft, and targets appear likely to merge, vector one or both aircraft to establish radar separation until the pilot reports clear of MWA • Issue flight level change or re-route, traffic-permitting
<ul style="list-style-type: none"> • Report location and magnitude of MWA to ATC 	<ul style="list-style-type: none"> • Issue PIREP to other aircraft concerned

RAC

Wake Turbulence Encounters

Pilot should:	ATC may be expected to:
<ul style="list-style-type: none"> • Contact ATC and request vector lateral offset or flight level change 	<ul style="list-style-type: none"> • Issue vector, lateral offset or flight level change, traffic-permitting

Failure of Automatic Altitude Control System, Altitude Alarmer or All Primary Altimeters

Pilot will	ATC will
<ul style="list-style-type: none"> • Contact ATC and advise "Unable RVSM Due Equipment" • Request Clearance out of RVSM unless operational situation dictates otherwise 	<ul style="list-style-type: none"> • Provide 2 000 ft vertical separation or appropriate horizontal separation • Clear aircraft out of RVSM airspace

One Primary Altimeter Remains Operational

Pilot will:	ATC will:
<ul style="list-style-type: none"> • Cross-check stand-by altimeter • Notify ATC of loss of redundancy, operation with single primary altimeter • If unable to confirm primary altimeter accuracy, follow action for failure of all primary altimeters 	<ul style="list-style-type: none"> • Acknowledge operation with single primary altimeter and monitor progress

RAC ANNEX

1.0 GENERAL

This annex contains those *Canadian Aviation Regulations* (CARs) that relate to the subject matter of this chapter, but may not have been incorporated, in full or in part, in the chapter text.

2.0 CANADIAN AVIATION REGULATIONS

Reckless or Negligent Operation of Aircraft

602.01

No person shall operate an aircraft in such a reckless or negligent manner as to endanger or be likely to endanger the life or property of any person.

Fitness of Flight Crew Members

602.02

No operator of an aircraft shall require any person to act as a flight crew member and no person shall act as a flight crew member, if either the person or the operator has any reason to believe, having regard to the circumstances of the particular flight to be undertaken, that the person

- (a) is suffering or is likely to suffer from fatigue; or
- (b) is otherwise unfit to perform properly the person's duties as a flight crew member.

Alcohol or Drugs – Crew Members

602.03

No person shall act as a crew member of an aircraft

- (a) within eight hours after consuming an alcoholic beverage;
- (b) while under the influence of alcohol; or
- (c) while using any drug that impairs the person's faculties to the extent that the safety of the aircraft or of persons on board the aircraft is endangered in any way.

Alcohol or Drugs – Passengers

602.04

(1) In this Section, "intoxicating liquor" means a beverage that contains more than 2.5 percent proof spirits.

- (2) No person shall consume on board an aircraft an intoxicating liquor unless the intoxicating liquor
 - (a) has been served to that person by the operator of the aircraft; or
 - (b) where no flight attendant is on board, has been provided by the operator of the aircraft.

- (3) No operator of an aircraft shall provide or serve any intoxicating liquor to a person on board the aircraft, where there are reasonable grounds to believe that the person's faculties are impaired by alcohol or a drug to an extent that may present a hazard to the aircraft or to persons on board the aircraft.
- (4) Subject to subsection (5), no operator of an aircraft shall allow a person to board the aircraft, where there are reasonable grounds to believe that the person's faculties are impaired by alcohol or a drug to an extent that may present a hazard to the aircraft or to persons on board the aircraft.
- (5) The operator of an aircraft may allow a person whose faculties are impaired by a drug to board an aircraft, where the drug was administered in accordance with a medical authorization and the person is under the supervision of an attendant.

Compliance with Instructions

602.05

- (1) Every passenger on board an aircraft shall comply with instructions given by any crew member respecting the safety of the aircraft or of persons on board the aircraft.
- (2) Every crew member on board an aircraft shall, during flight time, comply with the instructions of the pilot-in-command or of any person whom the pilot-in-command has authorized to act on behalf of the pilot-in-command.

Smoking

602.06

- (1) No person shall smoke on board an aircraft during takeoff or landing or when directed not to smoke by the pilot-in-command.
- (2) No person shall smoke in an aircraft lavatory.
- (3) No person shall tamper with or disable a smoke detector installed in an aircraft lavatory without permission from a crew member or the operator of the aircraft.

Aircraft Operating Limitations

602.07

No person shall operate an aircraft unless it is operated in accordance with the operating limitations

- (a) set out in the aircraft flight manual, where an aircraft flight manual is required by the applicable standards of airworthiness;
- (b) set out in a document other than the aircraft flight manual, where use of that document is authorized pursuant to Part VII;

- (c) indicated by markings or placards required pursuant to Section 605.05; or
- (d) prescribed by the competent authority of the state of registry of the aircraft.

Portable Electronic Devices

602.08

- (1) No operator of an aircraft shall permit the use of a portable electronic device on board an aircraft, where the device may impair the functioning of the aircraft's systems or equipment.
- (2) No person shall use a portable electronic device on board an aircraft except with the permission of the operator of the aircraft.

Carry-on Baggage, Equipment and Cargo

602.86

- (1) No person shall operate an aircraft with carry-on baggage, equipment or cargo on board, unless the carry-on baggage, equipment and cargo are
 - (a) stowed in a bin, compartment, rack or other location that is certified in accordance with the aircraft type certificate in respect of the stowage of carry-on baggage, equipment or cargo; or
 - (b) restrained so as to prevent them from shifting during movement of the aircraft on the surface and during takeoff, landing and inflight turbulence.
- (2) No person shall operate an aircraft with carry-on baggage, equipment or cargo on board unless
 - (a) the safety equipment, the normal and emergency exits that are accessible to passengers and the aisles between the flight deck and a passenger compartment are not wholly or partially blocked by carry-on baggage, equipment or cargo;
 - (b) all of the equipment and cargo that are stowed in a passenger compartment are packaged or covered to avoid possible injury to persons on board;
 - (c) where the aircraft is type-certificated to carry 10 or more passengers and passengers are carried on board,
 - (i) no passenger's view of any "seat belt" sign, "no smoking" sign or exit sign is obscured by carry-on baggage, equipment or cargo except if an auxiliary sign is visible to the passenger or another means of notification of the passenger is available,
 - (ii) all of the passenger service carts and trolleys are securely restrained during movement of the aircraft on the surface, takeoff and landing, and during inflight turbulence where the pilot-in-command or in-charge flight attendant has directed that the cabin be secured pursuant to subsection 605.25(3) or (4), and
 - (iii) all of the video monitors that are suspended from the ceiling of the aircraft and extend into an aisle are stowed and securely restrained during takeoff and landing; and

- (d) all of the cargo that is stowed in a compartment to which crew members have access is stowed in such a manner as to allow a crew member to effectively reach all parts of the compartment with a hand-held fire extinguisher.

Crew Member Instructions

602.87

The pilot-in-command of an aircraft shall ensure that each crew member, before acting as a crew member on board the aircraft, has been instructed with respect to

- (a) the duties that the crew member is to perform; and
- (b) the location and use of all of the normal and emergency exits and of all of the emergency equipment that is carried on board the aircraft.

Passenger Briefings

602.89

- (1) The pilot-in-command of an aircraft shall ensure that all of the passengers on board the aircraft are briefed before takeoff with respect to the following, where applicable:
 - (a) the location and means of operation of emergency and normal exits;
 - (b) the location and means of operation of safety belts, shoulder harnesses and restraint devices;
 - (c) the positioning of seats and the securing of seat backs and chair tables;
 - (d) the stowage of carry-on baggage;
 - (e) where the aircraft is unpressurized and it is possible that the flight will require the use of oxygen by the passengers, the location and means of operation of oxygen equipment; and
 - (f) any prohibition against smoking.
- (2) The pilot-in-command of an aircraft shall ensure that all of the passengers on board the aircraft are briefed
 - (a) in the case of an over-water flight where the carriage of life preservers, individual flotation devices or personal flotation devices is required pursuant to Section 602.62, before commencement of the over-water portion of the flight, with respect to the location and use of those items; and
 - (b) in the case of a pressurized aircraft that is to be operated at an altitude above FL250, before the aircraft reaches FL250, with respect to the location and means of operation of oxygen equipment.
- (3) The pilot-in-command of an aircraft shall, before takeoff, ensure that all of the passengers on board the aircraft are provided with information respecting the location and use of
 - (a) first aid kits and survival equipment;
 - (b) where the aircraft is a helicopter or a small aircraft that is an aeroplane, any ELT that is required to be carried on board pursuant to Section 605.38;
 - (c) and any life raft that is required to be carried on board pursuant to Section 602.63.

Noise Operating Criteria

602.105

No person shall operate an aircraft at or in the vicinity of an aerodrome except in accordance with the applicable noise abatement procedures and noise control requirements specified by the Minister in the *Canada Air Pilot* or *Canada Flight Supplement*, including the procedures and requirements relating to

- (a) preferential runways;
- (b) minimum noise routes;
- (c) hours when aircraft operations are prohibited or restricted;
- (d) arrival procedures;
- (e) departure procedures;
- (f) duration of flights;
- (g) the prohibition or restriction of training flights;
- (h) VFR or visual approaches;
- (i) simulated approach procedures; and
- (j) the minimum altitude for the operation of aircraft in the vicinity of the aerodrome.

Noise-Restricted Runways

602.106

- (1) Subject to subsection (2), no person shall operate a subsonic turbojet aeroplane that has a maximum certificated takeoff weight of more than 34 000 kg (74,956 pounds) on takeoff at a noise restricted runway set out in Column II of an item of the schedule at an aerodrome set out in Column I of that item, unless there is on board
 - (a) a certificate of airworthiness indicating that the aeroplane meets the applicable noise emission standards;
 - (b) a certificate of noise compliance issued in respect of the aeroplane; or
 - (c) where the aeroplane is not a Canadian aircraft, a document issued by the state of registry that specifies that the aeroplane meets the applicable noise emission requirements of that state.
- (2) Subsection (1) does not apply
 - (a) to the extent that it is inconsistent with any obligation assumed by Canada in respect of a foreign state in a treaty, convention or agreement;
 - (b) where the pilot-in-command of an aircraft has declared an emergency; or
 - (c) where an aircraft is operated on
 - (i) an air evacuation operation,
 - (ii) any other emergency air operation, or
 - (iii) a departure from an aerodrome at which it was required to land because of an emergency.

SCHEDULE (Section 602.106)

Item	Column I	Column II
	Aerodrome*	Noise Restricted Runways for Takeoff*
1.	Vancouver International Airport	08, 12
2.	Calgary International Airport	07, 10, 16, 25, 28
3.	Edmonton City Centre (Blatchford Field) Airport	All runways
4.	Edmonton International Airport	12
5.	Winnipeg International Airport	13, 18
6.	Hamilton Airport	06
7.	Toronto/Lester B. Pearson International Airport	06L, 06R, 15
8.	Ottawa/Macdonald-Cartier International Airport	32
9.	Montréal International Airport (Dorval)	All runways

* Information taken from the aeronautical information publication of the Department of Transport entitled Canada Flight Supplement.

Power-driven Aircraft – day VFR

605.14

No person shall conduct a takeoff in a power-driven aircraft for the purpose of day VFR flight unless it is equipped with

- (a) where the aircraft is operated in uncontrolled airspace, an altimeter;
- (b) where the aircraft is operated in controlled airspace, a sensitive altimeter adjustable for barometric pressure;
- (c) an airspeed indicator;
- (d) a magnetic compass or a magnetic direction indicator that operates independently of the aircraft electrical generating system;
- (e) a tachometer for each engine and for each propeller or rotor that has limiting speeds established by the manufacturer;
- (f) an oil pressure indicator for each engine employing an oil pressure system;
- (g) a coolant temperature indicator for each liquid-cooled engine;
- (h) an oil temperature indicator for each air-cooled engine having a separate oil system;
- (i) a manifold pressure gauge for each
 - (i) reciprocating engine equipped with a variable-pitch propeller,
 - (ii) reciprocating engine used to power a helicopter,
 - (iii) supercharged engine, and
 - (iv) turbocharged engine;

- (j) a means for the flight crew, when seated at the flight controls to determine
 - (i) the fuel quantity in each main fuel tank, and
 - (ii) if the aircraft employs retractable landing gear, the position of the landing gear;
- (k) subject to subsections 601.08(2) and 601.09(2), a radiocommunication system adequate to permit two-way communication on the appropriate frequency when the aircraft is operated within
 - (i) Class B, Class C or Class D airspace,
 - (ii) an MF area, unless the aircraft is operated pursuant to subsection 602.97(3), or
 - (iii) the ADIZ;
- (l) where the aircraft is operated under Subpart 4 of this Part, or under Subpart 3, 4 or 5 of Part VII, radiocommunication equipment adequate to permit two-way communication on the appropriate frequency;
- (m) where the aircraft is operated in Class B airspace, radio navigation equipment that will enable it to be operated in accordance with a flight plan; and
- (n) where the aircraft is operated under Subpart 4 of this Part or under Subpart 5 of Part VII, radio navigation equipment that is adequate to receive radio signals from a transmitting facility.

Power-driven Aircraft – VFR OTT

605.15

- (1) No person shall conduct a takeoff in a power-driven aircraft for the purpose of VFR OTT flight unless it is equipped with
 - (a) the equipment referred to in paragraphs 605.14(c) to (j);
 - (b) a sensitive altimeter adjustable for barometric pressure;
 - (c) a means of preventing malfunction caused by icing for each airspeed indicating system;
 - (d) a gyroscopic direction indicator or a stabilized magnetic direction indicator;
 - (e) an attitude indicator;
 - (f) subject to subsection (2), a turn and slip indicator or turn coordinator;
 - (g) where the aircraft is to be operated within the Northern Domestic Airspace, a means of establishing direction that is not dependent on a magnetic source;
 - (h) radiocommunication equipment adequate to permit two-way communication on the appropriate frequency; and
 - (i) radio navigation equipment adequate to permit the aircraft to be navigated safely.
- (2) Where the aircraft is equipped with a standby attitude indicator that is usable through flight attitudes of 360 degrees of pitch and roll for an aeroplane, or ±80 degrees of pitch and ±120 degrees of roll for a helicopter, the aircraft may be equipped with a slip-skid indicator in lieu of a turn and slip indicator or turn coordinator.

RAC

Power-driven Aircraft – Night VFR**605.16**

- (1) No person shall conduct a takeoff in a power-driven aircraft for the purpose of night VFR flight, unless it is equipped with
 - (a) the equipment referred to in paragraphs 605.14(c) to (n);
 - (b) a sensitive altimeter adjustable for barometric pressure;
 - (c) subject to subsection (2), a turn and slip indicator or turn coordinator;
 - (d) an adequate source of electrical energy for all of the electrical and radio equipment;
 - (e) in respect of every set of fuses of a particular rating that is installed on the aircraft and accessible to the pilot-in-command during flight, a number of spare fuses that is equal to at least 50 percent of the total number of installed fuses of that rating;
 - (f) where the aircraft is operated so that an aerodrome is not visible from the aircraft, a stabilized magnetic direction indicator or a gyroscopic direction indicator;
 - (g) where the aircraft is to be operated within the Northern Domestic Airspace, a means of establishing direction that is not dependent on a magnetic source;
 - (h) where the aircraft is an airship operated within controlled airspace, radar reflectors attached in such a manner as to be capable of a 360-degree reflection;
 - (i) a means of illumination for all of the instruments used to operate the aircraft;
 - (j) when carrying passengers, a landing light; and
 - (k) position and anti-collision lights that conform to the Aircraft Equipment and Maintenance Standards.
- (2) Where the aircraft is equipped with a standby attitude indicator that is usable through flight attitudes of 360 degrees of pitch and roll for an aeroplane, or ± 80 degrees of pitch and ± 120 degrees of roll for a helicopter, the aircraft may be equipped with a slip-skid indicator in lieu of a turn and slip indicator or turn coordinator.
- (3) No person shall operate an aircraft that is equipped with any light that may be mistaken for, or downgrade the conspicuity of, a light in the navigation light system, unless the aircraft is being operated for the purpose of aerial advertising.
- (4) In addition to the equipment requirements specified in subsection (1), no person shall operate an aircraft in night VFR flight under Subpart 4 of this Part or Subparts 2 to 5 of Part VII, unless the aircraft is equipped with
 - (a) an attitude indicator;
 - (b) a vertical speed indicator;
 - (c) a means of preventing malfunction caused by icing for each airspeed indicating system; and
 - (d) an outside air temperature gauge.

Use of Position and Anti-collision Lights**605.17**

- (1) Subject to subsection (2), no person shall operate an aircraft in the air or on the ground at night, or on water between sunset and sunrise, unless the aircraft position lights and anti-collision lights are turned on.
- (2) Anti-collision lights may be turned off where the pilot-in-command determines that, because of operating conditions, doing so would be in the interests of aviation safety.

Power-driven Aircraft – IFR**605.18**

- No person shall conduct a takeoff in a power-driven aircraft for the purpose of IFR flight unless it is equipped with
- (a) when it is operated by day, the equipment required pursuant to paragraphs 605.16(1)(a) to (h);
 - (b) when it is operated by night, the equipment required pursuant to paragraphs 605.16(1)(a) to (k);
 - (c) an attitude indicator;
 - (d) a vertical speed indicator;
 - (e) an outside air temperature gauge;
 - (f) a means of preventing malfunction caused by icing for each airspeed indicating system;
 - (g) a power failure warning device or vacuum indicator that shows the power available to gyroscopic instruments from each power source;
 - (h) an alternative source of static pressure for the altimeter, airspeed indicator and vertical speed indicator;
 - (i) sufficient radiocommunication equipment to permit the pilot to conduct two-way communications on the appropriate frequency; and
 - (j) sufficient radio navigation equipment to permit the pilot, in the event of the failure at any stage of the flight of any item of that equipment, including any associated flight instrument display,
 - (i) to proceed to the destination aerodrome or proceed to another aerodrome that is suitable for landing, and
 - (ii) where the aircraft is operated in IMC, to complete an instrument approach and, if necessary, conduct a missed approach procedure.

Balloons – Day VFR**605.19**

No person shall conduct a takeoff in a balloon for the purpose of day VFR flight unless it is equipped with

- (a) an altimeter;
- (b) a vertical speed indicator;
- (c) in the case of a hot air balloon,
 - (i) a fuel quantity gauge, and
 - (ii) an envelope temperature indicator;
- (d) in the case of a captive gas balloon, a magnetic direction indicator; and
- (e) subject to subsections 601.08(2) and 601.09(2), a radio communication system adequate to permit two-way communication on the appropriate frequency when the balloon is operated within
 - (i) Class C or Class D airspace,
 - (ii) an MF area, unless the aircraft is operated pursuant to subsection 602.97(3), or
 - (iii) the ADIZ.

Balloons – Night VFR**605.20**

No person shall conduct a takeoff in a balloon for the purpose of night VFR flight unless it is equipped with

- (a) equipment required pursuant to Section 605.19;
- (b) position lights;
- (c) a means of illuminating all of the instruments used by the flight crew, including a flashlight; and
- (d) in the case of a hot air balloon, two independent fuel systems.

Gliders – Day VFR**605.21**

No person shall operate a glider in day VFR flight unless it is equipped with

- (a) an altimeter;
- (b) an airspeed indicator;
- (c) a magnetic compass or a magnetic direction indicator; and
- (d) subject to subsections 601.08(2) and 601.09(2), a radiocommunication system adequate to permit two-way communication on the appropriate frequency when the glider is operated within
 - (i) Class C or Class D airspace,
 - (ii) an MF area, unless the aircraft is operated pursuant to subsection 602.97(3), or
 - (iii) the ADIZ.

Seat and Safety Belt Requirements**605.22**

- (1) Subject to subsection 605.23, no person shall operate an aircraft other than a balloon unless it is equipped with a seat and safety belt for each person on board the aircraft other than an infant.
- (2) Subsection (1) does not apply to a person operating an aircraft that was type-certificated with a safety belt designed for two persons.
- (3) A safety belt referred to in subsection (1) shall include a latching device of the metal-to-metal type.

Restraint System Requirements**605.23**

An aircraft may be operated without being equipped in accordance with Section 605.22 in respect of the following persons if a restraint system that is secured to the primary structure of the aircraft is provided for each person who is

- (a) carried on a stretcher or in an incubator or other similar device;
- (b) carried for the purpose of parachuting from the aircraft; or
- (c) required to work in the vicinity of an opening in the aircraft structure.

Shoulder Harness Requirements**605.24**

- (1) No person shall operate an aeroplane, other than a small aeroplane manufactured before July 18, 1978, unless each front seat or, if the aeroplane has a flight deck, each seat on the flight deck is equipped with a safety belt that includes a shoulder harness.
- (2) Except as provided in Section 705.75, no person shall operate a transport category aeroplane unless each flight attendant seat is equipped with a safety belt that includes a shoulder harness.
- (3) No person shall operate a small aeroplane manufactured after December 12, 1986, the initial type certificate of which provides for not more than nine passenger seats, excluding any pilot seats, unless each forward- or aft-facing seat is equipped with a safety belt that includes a shoulder harness.
- (4) No person shall operate a helicopter manufactured after September 16, 1992, the initial type certificate of which specifies that the helicopter is certified as belonging to the normal or transport category, unless each seat is equipped with a safety belt that includes a shoulder harness.

- (5) No person operating an aircraft shall conduct any of the following flight operations unless the aircraft is equipped with a seat and a safety belt that includes a shoulder harness for each person on board the aircraft:
 - (a) aerobatic manoeuvres;
 - (b) Class B, C or D external load operations conducted by a helicopter; and
 - (c) aerial application, or aerial inspection other than flight inspection for the purpose of calibrating electronic navigation aids, conducted at altitudes below 500 feet AGL.

General Use of Safety Belts and Restraint Systems

605.25

- (1) The pilot-in-command of an aircraft shall direct all of the persons on board the aircraft to fasten safety belts
 - (a) during movement of the aircraft on the surface;
 - (b) during takeoff and landing; and
 - (c) at any time during flight that the pilot-in-command considers it necessary that safety belts be fastened.
- (2) The directions referred to in subsection (1) also apply to the use of the following restraint systems:
 - (a) a child restraint system;
 - (b) a restraint system used by a person who is engaged in parachute descents; and
 - (c) a restraint system used by a person when working in the vicinity of an opening in the aircraft structure.
- (3) Where an aircraft crew includes flight attendants and the pilot-in-command anticipates that the level of turbulence will exceed light turbulence, the pilot-in-command shall immediately direct each flight attendant to
 - (a) discontinue duties relating to service;
 - (b) secure the cabin; and
 - (c) occupy a seat and fasten the safety belt provided.
- (4) Where an aircraft is experiencing turbulence and the in-charge flight attendant considers it necessary, the in-charge flight attendant shall
 - (a) direct all of the passengers to fasten their safety belts; and
 - (b) direct all of the other flight attendants to discontinue duties relating to service, to secure the cabin and to occupy their seats and fasten the safety belts provided.
- (5) Where the in-charge flight attendant has given directions in accordance with subsection (4), the in-charge flight attendant shall so inform the pilot-in-command.

Use of Passenger Safety Belts and Restraint Systems

605.26

- (1) Where the pilot-in-command or the in-charge flight attendant directs that safety belts be fastened, every passenger who is not an infant shall
 - (a) ensure that the passenger's safety belt or restraint system is properly adjusted and securely fastened;
 - (b) if responsible for an infant for which no child restraint system is provided, hold the infant securely in the passenger's arms; and
 - (c) if responsible for a person who is using a child restraint system, ensure that the person is properly secured.
- (2) No passenger shall be responsible for more than one infant.

Use of Crew Member Safety Belts

605.27

- (1) Subject to subsection (2), the crew members on an aircraft shall be seated at their stations with their safety belts fastened
 - (a) during takeoff and landing;
 - (b) at any time that the pilot-in-command directs; and
 - (c) in the case of crew members who are flight attendants, at any time that the in-charge flight attendant so directs pursuant to paragraph 605.25(4)(b).
- (2) Where the pilot-in-command directs that safety belts be fastened by illuminating the safety belt sign, a crew member is not required to comply with paragraph (1)(b)
 - (a) during movement of the aircraft on the surface or during flight, if the crew member is performing duties relating to the safety of the aircraft or of the passengers on board;
 - (b) where the aircraft is experiencing light turbulence, if the crew member is a flight attendant and is performing duties relating to the passengers on board; or
 - (c) if the crew member is occupying a crew rest facility during cruise flight and the restraint system for that facility is properly adjusted and securely fastened.
- (3) The pilot-in-command shall ensure that at least one pilot is seated at the flight controls with safety belt fastened during flight time.

Child Restraint System

605.28

- (1) No operator of an aircraft shall permit the use of a child restraint system on board the aircraft unless
 - (a) the person using the child restraint system is accompanied by a parent or guardian who will attend to the safety of the person during the flight;
 - (b) the weight and height of the person using the child restraint system are within the range specified by the manufacturer;
 - (c) the child restraint system bears a legible label indicating the applicable design standards and date of manufacture;
 - (d) the child restraint system is properly secured by the safety belt of a forward-facing seat that is not located in an emergency exit row and does not block access to an aisle; and
 - (e) the tether strap is used according to the manufacturer's instructions or, where subsection (2) applies, secured so as not to pose a hazard to the person using the child restraint system or to any other person.
- (2) Where a seat incorporates design features to reduce occupant loads, such as the crushing or separation of certain components, and the seat is in compliance with the applicable design standards, no person shall use the tether strap on the child restraint system to secure the system.
- (3) Every passenger who is responsible for a person who is using a child restraint system on board an aircraft shall be
 - (a) seated in a seat adjacent to the seat to which the child restraint system is secured;
 - (b) familiar with the manufacturer's installation instructions for the child restraint system; and
 - (c) familiar with the method of securing the person in the child restraint system and of releasing the person from it.

Flight Control Locks

605.29

- No operator of an aircraft shall permit the use of a flight control lock in respect of the aircraft unless
- (a) the flight control lock is incapable of becoming engaged when the aircraft is being operated; and
 - (b) an unmistakable warning is provided to the person operating the aircraft whenever the flight control lock is engaged.

De-icing or Anti-icing Equipment

605.30

- No person shall conduct a takeoff or continue a flight in an aircraft where icing conditions are reported to exist or are forecast to be encountered along the route of flight unless
- (a) the pilot-in-command determines that the aircraft is adequately equipped to operate in icing conditions in accordance with the standards of airworthiness under which the type certificate for that aircraft was issued; or
 - (b) current weather reports or pilot reports indicate that icing conditions no longer exist.

Oxygen Equipment and Supply

605.31

- (1) No person shall operate an unpressurized aircraft unless it is equipped with sufficient oxygen dispensing units and oxygen supply to comply with the requirements set out in the table to this subsection.

OXYGEN REQUIREMENTS FOR UNPRESSURIZED AIRCRAFT		
Item	Column I	Column II
	Persons For Whom Oxygen Supply Must Be Available	Period Of Flight And Cabin-Pressure-Altitude
1.	All crew members and 10 percent of passengers and, in any case, no less than one passenger	Entire period of flight exceeding 30 minutes at cabin-pressure-altitudes above 10 000 feet ASL but not exceeding 13 000 feet ASL
2.	All persons on board the aircraft	(a) Entire period of flight at cabin-pressure-altitudes above 13 000 feet ASL (b) For aircraft operated in an air transport service under the conditions referred to in paragraph(a), a period of flight of not less than one hour.

- (2) No person shall operate a pressurized aircraft unless it is equipped with sufficient oxygen dispensing units and oxygen supply to provide, in the event of cabin pressurization failure at the most critical point during the flight, sufficient oxygen to continue the flight to an aerodrome suitable for landing while complying with the requirements of the table to this subsection.

RAC

MINIMUM OXYGEN REQUIREMENTS FOR PRESSURIZED AIRCRAFT FOLLOWING EMERGENCY DESCENT (NOTE 1)

Item	Column I	Column II
	Persons For Whom Oxygen Supply Must Be Available	Period Of Flight And Cabin-Pressure-Altitude
1.	All crew members and 10 percent of passengers and, in any case, no less than one passenger	(a) Entire period of flight exceeding 30 minutes at cabin-pressure-altitudes above 10 000 feet ASL but not exceeding 13 000 feet ASL (b) Entire period of flight at cabin-pressure-altitudes above 13 000 feet ASL (c) For aircraft operated in an air transport service under the conditions referred to in paragraph (a) or (b), a period of flight of not less than (i) 30 minutes (Note 2), and (ii) for flight crew members, two hours for aircraft the type certificate of which authorizes flight at altitudes exceeding FL250 (Note 3)
2.	All passengers	(a) Entire period of flight at cabin-pressure-altitudes exceeding 13 000 feet ASL (b) For aircraft operated in an air transport service under the conditions referred to in paragraph (a), a period of flight of not less than 10 minutes

NOTES 1: In determining the available supply, the cabin pressure altitude descent profile for the routes concerned must be taken into account.

2: The minimum supply is that quantity of oxygen necessary for a constant rate of descent from the aircraft's maximum operating altitude authorized in the type certificate to 10 000 feet ASL in 10 minutes, followed by 20 minutes at 10 000 feet ASL.

3: The minimum supply is that quantity of oxygen necessary for a constant rate of descent from the aircraft's maximum operating altitude authorized in the type certificate to 10 000 feet ASL in 10 minutes, followed by 110 minutes at 10 000 feet ASL.

Use of Oxygen

605.32

- (1) Where an aircraft is operated at cabin-pressure-altitudes above 10 000 ft ASL, but not exceeding 13 000 ft ASL, each crew member shall wear an oxygen mask and use supplemental oxygen for any part of the flight at those altitudes that is more than 30 min in duration.
- (2) Where an aircraft is operated at cabin-pressure-altitudes above 13 000 ft ASL, each person on board the aircraft shall wear an oxygen mask and use supplemental oxygen for the duration of the flight at those altitudes.
- (3) The pilot at the flight controls of an aircraft shall use an oxygen mask if
 - (a) the aircraft is not equipped with quick-donning oxygen masks and is operated at or above FL250; or
 - (b) the aircraft is equipped with quick-donning oxygen masks and is operated above FL410.

3.0 TRANSPORTATION OF DANGEROUS GOODS (TDG) BY AIR

Dangerous goods refers to a product, substance or organism included by its nature or by the regulations in any of the classes listed in the schedule to the *Transportation of Dangerous Goods Act, 1992*. There are nine classes of dangerous goods:

- Class 1: Explosives;
- Class 2: Gases;
- Class 3: Flammable liquids;
- Class 4: Flammable solids; substances liable to spontaneous combustion; substances that on contact with water emit flammable gases;
- Class 5: Oxidizing substances and organic peroxides;
- Class 6: Toxic and infectious substances;
- Class 7: Radioactive materials;
- Class 8: Corrosives; and
- Class 9: Miscellaneous products, substances or organisms.

Dangerous goods shall not be carried on board any Canadian aircraft, or in any foreign aircraft when operated in Canada, unless in compliance with the *Transportation of Dangerous Goods Act, 1992*, (TDG Act, 1992) and the *Transportation of Dangerous Goods Regulations* (TDG Regulations).

Sections 12.1 to 12.3 of the TDG Regulations regulate the domestic and international transport of dangerous goods by air, and adopt by reference the *ICAO Technical Instructions for the Safe Transport of Dangerous Goods by Air* (ICAO TIs).

Sections 12.4 to 12.17 of the TDG Regulations provide alternative domestic provisions for dangerous goods in air transport, which address the unique characteristics of the Canadian aviation industry and geographical environment. **NOTE:** Activities related to the handling, offering for transport or transporting of dangerous goods by air, which are not consistent with the TDG Act, 1992 or the TDG Regulations, require an equivalency certificate issued under section 31 of the TDG Act, 1992, and section 14.1 of the TDG Regulations.

Canadian Air Operators are required to submit procedures for the carriage of dangerous goods and corresponding TDG Training Program to TC for review and approval. TC published *Advisory Circular (AC) 700-001- Procedures for the Carriage of Dangerous Goods to the Company Operations Manual* and *AC 700-008 – Development of a Dangerous Goods Training Program* to assist air operators in the development of dangerous goods procedures and training program. The ACs are found on the Transport Canada Civil Aviation (TCCA) documentation website: <www.tc.gc.ca/eng/civilaviation/opssvs/management-services-reference-centre-ac-700-menu-511.htm>.

NOTE: Consultants may provide assistance in developing dangerous goods procedures and training programs; however, generic procedures and training programs may need to be amended to reflect air operators' activities.

Anyone handling, offering for transport, transporting or importing dangerous goods in Canada must be trained and hold a valid training certificate in compliance with Part 6, Training, of the TDG Regulations. An air operator can delegate some of its responsibilities to third parties; however, the air operator remains accountable. Therefore, an air operator is responsible for training employees (and third party staff) who handle, offer for transport, or transport dangerous goods based on the approved dangerous goods procedures and TDG training program. Employees (and third party staff) can also perform TDG duties if in the presence and under the direct supervision of a person who is trained and who holds a TDG training certificate. A TDG training certificate expires 24 months after its date of issuance.

Guidance material and additional information can be obtained from one of the following TCCA TDG regional offices:

Headquarters—National Capital Region AARXE
Place de Ville, Tower C
330 Sparks St, 4th Floor
Ottawa ON K1A 0N8
Tel: 613-990-1060
Fax: 613-954-1602

Quebec Region—NAXD
Commercial and Business Aviation
700 Leigh Capreol
Pierre Elliott Trudeau International Airport
Dorval QC H4Y 1G7
Tel: 514-633-2838
Fax: 514-633-3697

Atlantic Region—MAXD
Commercial and Business Aviation
P.O. Box 42,
Heritage Court
Moncton NB E1C 8K6
Tel: 506-851-7247
Fax: 506-851-7190

Pacific Region—TAXD
Commercial and Business Aviation
800 Burrard Street, Suite 620
Vancouver BC V6Z 2J8
Tel: 604-666-5655
Fax: 604-666-0682

Ontario Region—PAXD—PIA
Commercial and Business Aviation
5431 Flightline Drive
Pearson International Airport
Mississauga ON L5P 1B2
General Information: 416-952-0000
Fax: 905-405-3305

Prairie and Northern Region—RAEX
Commercial and Business Aviation
1100 Jasper Place
9700 Jasper Avenue
Edmonton AB T5J 4E6
Tel: 780-495-5278
Fax: 780-495-4622

Winnipeg Office
Tel: 204-495-1424
Fax: 204-495-1734

National Operations—NAROA
700 Leigh Capreol Suite 2093
Pierre Elliott Trudeau International Airport
Dorval QC H4Y 1G7
Tel: 514-633-3116
Fax: 514-633-3717



FAL – FACILITATION

1.0 GENERAL INFORMATION

1.1 GENERAL

The requirements for entry and departure of aircraft engaged in international flights, and the standard procedure for clearance of these aircraft at all international airports are given for the information and guidance of operators conducting international flights. The information contained in this section does not replace, amend or change in any manner, the current regulations of the designated authorities that are of concern to international air travel. Discrepancies noted in the information contained in this section should be reported to:

TC AIM Co-ordinator (AARTT)
 Transport Canada
 330 Sparks Street
 Ottawa ON K1A 0N8

Tel.: 613-993-4502
 Fax: 613-952-3298
 E-mail: alain.piche@tc.gc.ca

1.2 DESIGNATED AUTHORITIES

The addresses of the designated authorities concerned with the entry, transit and departure of international air traffic are as follows:

(a) Customs:

Operational concerns:

Canada Border Services Agency
 Operations Branch
 Operational Programs Directorate
 People Processing Division
 Port of Entry Operations

Tel.: 1-800-461-9999 (EN)
 Tel.: 1-800-959-2036 (FR)
 Fax: 613-941-5691
 Email: CBSA-ASFC@canada.gc.ca

(b) Immigration:

Citizenship and Immigration Canada
 365 Laurier Avenue West
 Ottawa ON K1A 1L1
 Canada

Tel.: 1-888-242-2100 (Canada)

If anywhere outside of Canada, contact the Canadian embassy, high commission or consulate responsible for your region. For contact information, refer to the Visa Offices section of Citizenship and Immigration Canada's Web site:

<www.cic.gc.ca/english/information/offices/missions.asp>.

(c) Health:

Health Canada
 Tunney's Pasture, 1918-A-1
 Ottawa ON K1A 0K9
 Canada

Tel.: 613-957-2991
 Fax: 613-941-5366

(d) Agriculture:

Importation of animals and their products:

Canadian Food Inspection Agency
 Animal Health and Production Division
 59 Camelot Drive
 Ottawa ON K1A 0Y9
 Canada

Tel.: 613-225-2342, ext. 4629
 Fax: 613-228-6630

Importation of plants and seeds:

Canadian Food Inspection Agency
 Plant Health Division
 59 Camelot Drive
 Ottawa ON K1A 0Y9
 Canada

Tel.: 613-225-2342, ext. 4334
 Fax: 613-228-6605

Importation of endangered species (plant, animal and by-products):

Environment Canada
 Canadian Wildlife Service
 Place Vincent Massey, 3rd floor
 351 St-Joseph Boulevard
 Gatineau QC K1A 0H3
 Canada

Tel.: 819-997-1840
 Fax: 819-953-6283

(e) Air transport services (overflights and technical stops):

Transport Canada
 International Operations Branch
 Foreign Inspection Division (AARJF)
 Enterprise Building, 11th floor, Suite 1110
 427 Laurier Avenue West
 Ottawa ON K1R 7Y2
 Canada

Tel.: 613-990-1100
 Fax: 613-949-4227
 Cell (Outside of normal working hours): 613-218-9079
 AFTN: CYHQYAYB

NOTE: Under normal circumstances, foreign air operators are encouraged to use a fax as the preferred method of contacting the Foreign Inspection Division. In a time-critical situation, the Transport Canada Civil Aviation Contingency Operations (CACO) Aviation Operations Centre may be reached 24 hours a day by calling 613-992-6853 or 1-877-992-6853.



2.0 ENTRY, TRANSIT AND DEPARTURE OF AIRCRAFT

2.1 GENERAL

- (a) All flights into, from, or over the territory of Canada and landings in such territory shall be carried out in accordance with the regulations of Canada regarding civil aviation.
- (b) Aircraft landing in or departing from the territory of Canada must first land at an aerodrome at which customs control facilities have been provided (refer to the CFS).

2.2 COMMERCIAL FLIGHTS

Operators of international commercial flights should consult AGA 1.2 for further information on international airports and ICAO definitions.

2.2.1 Aerodrome Use for Commercial Flights

The following aerodromes can be used by aircraft flying on international operations (other than flights between Canada and the U.S.).

Regular-use aerodromes:

- Calgary International
- Jean Lesage International (Québec)
- CFB Goose Bay (1) (2)
- St. John's
- Edmonton International
- Stephenville (5)
- Gander International
- Lester B. Pearson International (Toronto)
- Halifax International
- Vancouver International
- Hamilton
- Victoria (4)
- Greater Moncton International
- Winnipeg International
- Pierre Elliott Trudeau International (Montréal)
- Macdonald-Cartier International (Ottawa)

Alternate-use aerodromes—Refuelling only:

- CFB Goose Bay (2)
- Iqaluit
- Stephenville
- Prince George

Alternate-use aerodromes:

- Abbotsford
- CFB Comox (3)
- CFB Goose Bay (1) (2)

General aviation operators are not limited to the list above. They must consult the CFS for necessary information.

- NOTES:**
1. CFB Goose Bay may be used by all international and domestic general aviation and commercial aircraft. No prior permission required for civilian aircraft (military users: refer to the CFS).
 2. Supplies and services for passengers at CFB Goose Bay are limited. Use of CFB Goose Bay as an alternate or refuelling stop should be planned accordingly.
 3. While a runway at CFB Comox aerodrome is suitable for large aircraft engaged in international operations, it must be noted that facilities for refuelling and handling large civil aircraft and for the provision of immigration, health and passenger amenity services are extremely limited. Operators using the CFB Comox aerodrome as an international alternate and requiring the above-mentioned services can anticipate extensive delays and passenger discomfort.
 4. For use by non-scheduled international services.
 5. For regular use—general aviation

2.2.2 International Commercial Flights Operating into and out of Canada or Transiting Canadian Airspace

All flights of aircraft operated by a foreign air operator into or out of a Canadian destination or transiting Canadian airspace are to be conducted in accordance with the following procedures:

(a) Air transport services into and out of Canada

- (i) Scheduled international services

The following requirements apply to all foreign air operators intending to conduct a scheduled air transport service into or out of Canada. The air operator must:

 - (A) hold a Canadian foreign air operator certificate (FAOC) issued by the Minister of Transport pursuant to section 701.01 of the CARs;
 - (B) be designated pursuant to a bilateral air services agreement between Canada and the foreign air operator's State of certification, or according to any other arrangement between the two States; and
 - (C) be in possession of a licence to operate a scheduled international service issued by the Canadian Transportation Agency.
- (ii) Non-scheduled international services

The following requirements apply to all foreign air operators intending to conduct a non-scheduled air transport service into or out of Canada. The air operator must:

 - (A) hold a Canadian FAOC issued by the Minister of Transport pursuant to section 701.01 of the CARs;

- (B) obtain prior permission from the Canadian Transportation Agency unless the air transport service is otherwise provided for in a bilateral air services agreement between Canada and the foreign air operator's State of certification; and
- (C) be in possession of a licence to operate a non-scheduled international service issued by the Canadian Transportation Agency.

(b) Air transport services transiting Canadian airspace or conducting technical stops at Canadian airports— Aircraft registered in an ICAO Member State

- (i) By an air operator who holds a current Canadian FAOC valid for the type of aircraft being operated:
 - (A) Both scheduled and non-scheduled flights through Canadian airspace, including technical stops at Canadian airports, are permitted without seeking further authority from Transport Canada.
- (ii) By an air operator who does not hold a Canadian FAOC valid for the type of aircraft being operated:
 - (A) The foreign air operator must request a flight authorization 10 working days before the flight. The request must include the following information:
 - the name of the foreign air operator and the call sign of the flight(s);
 - the type of aircraft, the aircraft registration and the seating capacity;
 - a list of the dangerous goods being carried or, if no dangerous goods are being carried, a statement that reads: *No dangerous goods are being carried*;
 - a statement that reads: *The aircraft is airworthy and is being operated under the authority of a normal certificate of airworthiness that has been issued pursuant to Article 31 of the Convention on International Civil Aviation*; and
 - the proposed flight routing, including the last point of departure outside Canada; the first point of entry into Canada; the date and time of arrival at, and departure from, any Canadian airport(s); and the place(s) of embarkation and disembarkation abroad of passengers and freight.
 - (B) The request shall be forwarded to the Foreign Inspection Division Overflight Desk by any of the following means:
 - AFTN:CYHQYAYB
 - Fax:613-949-4227
 - E-mail:overflights-survol@tc.gc.ca
 Foreign Operations Applications and Inquiries – Applications
 - E-mail:FOA-AOE@tc.gc.ca

(c) Air transport service transiting Canadian airspace or conducting technical stops at Canadian airports— Aircraft registered in a non-ICAO Member State

Pursuant to the CARs, a foreign air operator of aircraft registered in a State that is not a signatory to the *ICAO Convention on International Civil Aviation* must obtain permission through diplomatic channels prior to operating a flight to or from a Canadian airport or through Canadian airspace. The State of the operator must provide full details of the flight in a diplomatic note to the Department of Foreign Affairs and International Trade, including:

- (i) the name of the foreign air operator and the call sign of the flight(s);
- (ii) the type of aircraft, the aircraft registration and the seating capacity;
- (iii) a list of the dangerous goods being carried or, if no dangerous goods are being carried, a statement that reads: *No dangerous goods are being carried*;
- (iv) a statement that reads: *The aircraft is airworthy and is being operated under a flight authority that is equivalent to the certificates of airworthiness that are issued pursuant to Article 31 of the Convention on International Civil Aviation*;
- (v) the proposed flight routing, including the last point of departure outside Canada; the first point of entry into Canada; the date and time of arrival at, and the departure from, any Canadian airport(s); and the place(s) of embarkation and disembarkation abroad of passengers and freight.

(d) State aircraft flights to and from a Canadian airport or transiting Canadian airspace

Pursuant to Article 3 of the *Convention on International Civil Aviation*, the foreign air operator of State aircraft must obtain permission through diplomatic channels prior to operating a flight to or from a Canadian airport or one that transits Canadian airspace. The State of the operator must provide full details of the flight in a diplomatic note to the Department of Foreign Affairs and International Trade, including:

- (i) the name of the foreign air operator and the call sign of the flight(s);
- (ii) the type of aircraft and the aircraft registration or identification;
- (iii) the proposed flight routing, including the last point of departure outside Canada; the first point of entry into Canada; the date and time of arrival at, and departure from, any Canadian airport(s); and the place(s) of embarkation and disembarkation abroad of passengers and freight.

(e) Aircraft flights operated pursuant to a flight authority other than a normal certificate of airworthiness (References: Article 31 of the Convention on International Civil Aviation and ICAO Annex VIII)

Where a foreign-registered aircraft is intended to be operated to or from a Canadian airport or through Canadian airspace under the authority of a special flight permit or special flight authority and the aircraft does not conform to Article 31 of the *Convention on International Civil Aviation*, Transport Canada must validate the special flight permit or authority prior to the flight being conducted.

The operator of the aircraft must contact the Foreign Inspection Division, Transport Canada, and obtain a validation of its special flight permit or authority prior to operating one or more flights to or from a Canadian airport or through Canadian airspace.

NOTES:

- 1. To initiate the process of obtaining a Canadian FAOC, interested foreign air operators should contact the Foreign Inspection Division, Transport Canada, at the following address:

Transport Canada
 International Operations Branch
 Foreign Inspection Division (AARJF)
 Enterprise Building, 11th floor, Suite 1110
 427 Laurier Avenue West
 Ottawa ON K1R 7Y2
 Canada

Tel.: 613-990-1100
 Fax: 613-949-4227

Foreign Operations Applications and Inquiries – Applications

• E-mail: FOA-AOE@tc.gc.ca

- 2. To be designated pursuant to a bilateral agreement, air operators should consult with their regulatory authority.

- 3. To apply for a licence, air operators should contact the Canadian Transportation Agency at the following address:

Secretary
 Canadian Transportation Agency
 15 Eddy Street
 Gatineau QC K1A 0N9
 Canada

Tel.: 819-997-6359
 Fax: 819-953-5562
 Telex: 819-953-4254
 After hours: 613-769-6274

- 4. Off-loading of traffic during a technical stop at a Canadian airport will be permitted where circumstances so require to ensure the safety of persons or property. Permission to transfer the traffic and/or crew to another aircraft must be obtained from Transport Canada and the Canadian inspection services: Canada Border Services Agency; Citizenship and Immigration Canada; Health Canada; and the Canadian Food Inspection Agency.

- 5. The following information is required if the aircraft is carrying dangerous goods:
 - (i) the class, quantity (weight in each class), and shipping name of the dangerous goods and the United Nations number, as well as a statement indicating that the dangerous goods are packaged in accordance with the International Air Transport Association (IATA) regulations and ICAO requirements, and, if applicable, the *Nuclear Safety and Control Act*; and
 - (ii) confirmation that the civil aviation authority of the State from which the flight originates and the civil aviation authority of the air operator’s State have authorized the flight.

- 6. An operator must apply for a flight authority validation and submit the following documents, along with the required fee, to the fax number or address below:

- i) a copy of the certificate of registration for the aircraft;
- (ii) a copy of the special flight permit or special flight authority, including all conditions required to be complied with when the aircraft is being operated;
- (iii) the flight routing, including airport of departure, technical stops and airport of arrival;
- (iv) a fee of \$100 in Canadian funds in the form of either a cheque (payable to the Receiver General of Canada) or the credit card details for a Mastercard or Visa card (including the name of the card, the name of the card holder, the card number and the card’s expiry date); the fee will then be debited by Transport Canada.

Transport Canada
 International Operations Branch
 Foreign Inspection Division (AARJF)
 Enterprise Building, 11th floor, Suite 1110
 427 Laurier Avenue West
 Ottawa ON K1R 7Y2
 Canada

Tel.: 613-990-1100 (general inquiries)
 Fax: 613-949-4227

Foreign Operations Applications and Inquiries – Applications

• E-mail: FOA-AOE@tc.gc.ca

- 7. *Airport access:* Unless operational requirements dictate otherwise, technical stops for foreign air operators will be restricted to the following international airports:

- Calgary (CYYC)
- Goose Bay (CYYR) (Military)
- Edmonton (CYEG)
- Gander (CYQX)
- Halifax (CYHZ)
- Hamilton (CYHM)
- Montréal-Dorval (CYUL)
- Ottawa (CYOW)
- Québec (CYQB)

St. John's (CYYT)
Stephenville (CYJT)
Toronto (CYYZ)
Vancouver (CYVR)
Victoria (CYYJ)
Winnipeg (CYWG)

- (i) At civilian airports, the foreign air operator is responsible for notifying the airport manager and Canada customs before the flight.
- (ii) PPR is normally necessary at military (DND) airports.
- (iii) For current airport information, flight crews should consult the CFS or an equivalent document.

2.2.3 Use of DND and Civil High Arctic Aerodromes

Commercial air operators wanting to use these aerodromes are to apply to:

Transport Canada
Attn: Director General, Civil Aviation
330 Sparks Street, 5th floor
Tower C, Place de Ville
Ottawa ON K1A 0N8

Details concerning the type of aircraft, servicing requirements and scheduling should accompany the request.

Private operators may apply directly to the appropriate DND Base Commander or contact Wing Operations at the telephone number listed in the CFS.

Alert, NWT—Commercial air operators are to apply to:

Transport Canada
Attn: Director General, Civil Aviation
330 Sparks Street, 5th Floor
Ottawa ON K1A 0N8
Tower C, Place de Ville

Private operators are to apply to:

National Defence Headquarters
DISO/DIMOD 5-3
473 Albert Street
5th Floor, Trebla Bldg
Ottawa ON K1A 0K2

NU—Eureka aerodrome was established and is operated to support the High Arctic Weather Stations. Facilities are extremely limited. Requests for meals and accommodations are to be made to:

Atmospheric Environment Services,
Prairie and Northern Region
Attn: Station Program Manager, Eureka
Suite 150-123 Main Street
Winnipeg MB R3C 4W2

Tel.: 204-983-4757
Fax: 204-984-2072
e-mail: stationprogrammanager@ec.gc.ca

2.2.4 Documents Required by Passengers for Canadian Inspection Services

Entry

Requirements for Passports

An air operator is required to present each passenger seeking entry to Canada to the Canadian Inspection Services (CIS) at a place designated for that purpose. Failure to do so is an offence and the company is liable to a fine as determined by the CIS in respect of each passenger not presented.

ALL VISITORS, including visiting crew members, to Canada require valid passports except:

- a citizen of the U.S.;
- a visitor seeking entry from the U.S. or St-Pierre et Miquelon who has been lawfully admitted to the U.S. for permanent residence;
- a resident of Greenland entering Canada from Greenland;
- French citizens who reside permanently in St-Pierre et Miquelon, seeking entry from St-Pierre et Miquelon;
- a member of the armed forces of any designated state entering Canada pursuant to the *Visiting Forces Act*; and
- a visitor who is seeking entry as, or in order to become, a member of the crew of a vehicle and who is in possession of a seaman's identity document issued to him/her pursuant to International Labour Organization conventions *or is in possession of an airline flight crew licence or crew member certificate issued to him/her in accordance with International Civil Aviation Organization specifications. The flight crew licence holder must be a member of the operating crew.*

In addition, certain identity or travel documents may be accepted by immigration authorities. A list of acceptable documents may be obtained from Citizenship and Immigration Canada (see FAL 1.2 for address).

ALL IMMIGRANTS to Canada require valid passports, except a Convention Refugee who is in possession of a valid and subsisting immigrant visa. Any immigrant not in possession of a passport or one of the specified alternatives may be refused entry to Canada and removed at the air operator's expense. In addition, certain travel documents may be acceptable, a list of which can be obtained from Citizenship and Immigration Canada (see FAL 1.2).

2.2.5 Requirement for Visas

Any air operator who carries to Canada a person who is required to obtain a visa before appearing at an airport of entry and who is not in possession of a valid visa is guilty of an offence and is liable to a fine as determined by the CIS.

An IMMIGRANT visa is that portion of form IMM 1000 “Immigrant Visa and Record of Landing” that has been validated by a Canadian visa officer, and unless the immigrant is in possession of such visa, he/she may be refused admission to Canada and removed at the air operator’s expense.

In accordance with the *Immigration Act*, “visa” means a document issued or a stamp impression made on a document by a visa officer.

A visitor to Canada who is required to obtain a visa before appearing at an airport of entry and who is not in possession of a valid visa may be refused admission to Canada and removed at the air operator’s expense.

Without exception, every IMMIGRANT seeking to land in Canada must be in possession of a valid and subsisting immigrant visa.

A VISITOR visa may be required by citizens of some countries; contact Canadian immigration authorities for details (see FAL 1.2).

- (1) Persons requiring visas to enter Canada must also be in possession of a visa to transit through Canada.
- (2) Persons who are in transit through Canada on a flight that stops in Canada solely for the purpose of refuelling are exempt from the visitor visa requirement if they are on a flight bound for the U.S. and have a valid U.S. visa or were lawfully admitted to the U.S. and are on a flight originating in the U.S.

Departure formalities are not required for embarking passengers.

2.2.6 Documents Required by CIS for Cargo/ Passenger Baggage

Entry

- (a) Scheduled or non-scheduled commercial air operators operating international flights will not be required to submit a general declaration or equivalent document when the deplaning passengers and crew are processed by Customs personnel at a Customs facility established for that purpose.

- (b) All cargo carried in this connection will be reported on a cargo control document acceptable to Canada Customs. This means that all air cargo must be reported on an IATA international format Air Way Bill or a Canadian Customs Cargo Control document. Air operators operating “all cargo flights” will not be required to submit a general declaration or equivalent document when such freight is reported on a cargo control document acceptable to Canada Customs.

Exit

A general declaration or equivalent document will not be required for any aircraft departing Canada. However, there may be occasions when a declaration or other document is deemed necessary for presentation at the first airport of entry and CIS may assist the operator in developing and processing general declaration documents.

2.3 PRIVATE FLIGHTS

2.3.1 General

Private aircraft overflying or landing in Canada for non-commercial purposes need not obtain prior permission; however, a flight plan must be filed.

For Customs purposes, private aircraft are considered to be any civil aircraft engaged in a personal or business flight to or from Canada and not carrying passengers and/or cargo for compensation or hire.

Customs officers determine whether or not an aircraft pilot and/or crew is operating in a private or commercial capacity. The owner, aircraft type or predominant usage of the aircraft has little bearing on this determination. Many corporate and business aircraft operate as “private aircraft” and, conversely, individually-owned aircraft may operate for compensation.

The term “passengers and/or cargo carried for compensation or hire” means a passenger(s) and/or cargo transported where some payment or other consideration including monetary or services rendered is provided and the passengers and/or cargo are not connected with the operation of the aircraft, ownership or business.

For visa and document requirements, refer to FAL 2.2.4, 2.2.5 and 2.2.6.

2.3.2 Transborder Flights

According to section 602.73 of the CARs, a flight plan must be filed for all flights between Canada and a foreign State. A transborder flight is a flight between Canada and the U.S.

(a) *Flights from Canada to the United States*

U.S. Customs and Border Protection (CBP) requires private aircraft pilots or their designees arriving in the U.S. from a foreign location, or departing the U.S. for a foreign location, to transmit electronically to CBP passenger manifest information for each individual travelling on board the aircraft. The CBP requires private aircraft pilots or their designees to provide additional data elements when submitting a notice of arrival and also requires them to submit a notice of departure. Private aircraft pilots or their designees are required to submit the notice of arrival and notice of departure information to CBP in the same transmission as the corresponding arrival or departure passenger manifest information via the Electronic Advance Passenger Information System (eAPIS) or an approved alternate system. Data must be received by CBP no later than 60 min before an arriving private aircraft departs from a foreign location destined for the U.S. and no later than 60 min before a private aircraft departs a U.S. airport or location for a foreign place. ADCUS and CANPASS notifications are no longer accepted on flight plans for transborder flights departing from Canada to the U.S.

Private pilots or their designees are required to set up an eAPIS account at least five days prior to their first transborder flight. For additional information, consult the CBP web site at <www.cbp.gov>.

The publication *U.S. Customs and Border Protection Guide for Private Flyers* outlines special arrangements and restrictions applicable to U.S. airports. This publication is available online at the following address <www.cbp.gov/xp/cgov/travel/pleasure_boats/private_flyers>.

(b) *Flights from the United States to Canada*

Pilots must land at a Canada Border Services Agency (CBSA) authorized AOE. The CBSA does not require citizenship information on flight plans.

Aerodromes that are designated as AOE with customs services available are indicated in the Aerodrome/Facility Directory of the CFS or the WAS. ADCUS notification is no longer accepted on flight plans for transborder flights departing the U.S. to Canada, and pilots must make their own customs arrangements by calling 1-888-226-7277 at least 2 hr, but not more than 48 hr, prior to arrival in Canada (see FAL 2.3.3). Pilots must call 1-888-226-7277 again to report any change in the ETA, point of arrival or other information. If a customs officer is not there

to meet the aircraft when it arrives, the pilot must call 1-888-226-7277 again. An officer at the reporting centre will advise what to do at that time. No one is permitted to exit the aircraft until authorization is given by customs, except the pilot making the phone call. Pilots are also cautioned that for flight arrivals outside of the established hours of operation, the provision of customs services may not always be available. Where available, call-out charges may be levied.

2.3.3 Documentary Requirements for Customs Clearance of Aircraft

Entry

Where the class of aircraft is private, business, tourist or military, they will not be required to submit a general declaration; however, they are required to report verbally to Customs and the aircraft may be recorded on a specified Canada Customs supplied form to ensure adequate control of the aircraft while it is in Canada.

In the Northwest Territories (North of 60 parallel), where Customs procedures are enforced by a party other than Customs, (RCMP officers or employees of a Canadian government agency), the General Declaration will be required.

CANPASS—Private Aircraft Program

Travellers on a Canadian or U.S. registered private-owned, company-owned, or small charter aircraft carrying no more than 15 passengers, arriving directly from the U.S., must use a telephone reporting system to receive permission from a Customs or an Immigration officer to enter Canada. At least two hours, but not more than 48 hours before flying into Canada they must call 1 888 CANPASS (equates to 1 888 226 - 7277). For flights commencing outside the geographical areas covered under the 1 888-CANPASS number, refer to the Customs Section of the CFS for appropriate telephone numbers.

If the aircraft lands at a site not designated as a customs AOE due to weather conditions or other emergency, the pilot shall call 1 888 226-7277 or the nearest RCMP office as soon as possible.

Medevacs should enter Canada via a staffed AOE or AOE/15 within the hours of operations listed in the CFS. All arrangements for custom clearance should be done through the Customs Telephone Reporting Centre (1 888 226-7277) at least two hours prior to landing.

(a) *Permit holders:*

- (i) must contact 1 888 226-7277, at least two hours, but not more than 48 hours before entering Canada.
- (ii) can arrive at any approved AOE during airport hours of operation. (**NOTE:** Most municipally owned airports and some privately owned public-use airports may qualify if located within 100 km of Customs service.)

- (iii) must inform the Customs officer of the ETA, airport of destination, CANPASS—Private Aircraft permit number, full name, birth date, citizenship and purpose and length of stay in Canada for travellers who are not returning residents.
- (b) *Non-permit holders:*
 - (i) must arrive during Customs office hours at a designated AOE.
 - (ii) must contact 1 888 226-7277 at least two hours, but not more than 48 hours before entering Canada and provide the ETA, as well as their destination.
 - (iii) must provide: full name, birth date and citizenship for each person on board, purpose and length of stay in Canada, if travellers are not returning residents, and passport and visa details, if applicable.
 - (iv) must telephone, upon arrival at destination, 1 888 226-7277 a second time to inform an officer of their arrival. The Customs officer will be advised if the non-permit holders are free to leave the area and enter Canada, or if they must wait for Customs and Immigration officers for completion of documentation or a routine inspection.

- NOTES:**
1. Any aircraft with a mix of permit and non-permit holders must follow the procedures listed in FAL 2.3.3(b).
 2. Penalties for non-compliance or misrepresentation may range from loss of pre-approved privileges to seizure of the aircraft and/or criminal prosecution.
 3. For more information on the CANPASS—Private Aircraft Program, call 1 800 461-9999.

Exit

Same requirements as for commercial flights. (See FAL 2.2.6)

2.3.4 Public Health Measures and Requirements Regarding Passports and Visas

Same requirements as for commercial flights (See FAL 2.2.5 and 2.2.6).

2.4 PUBLIC HEALTH MEASURES APPLIED TO AIRCRAFT

Document requirements are the same for commercial and private flights (see FAL 2.3.3).

Garbage must be removed from aircraft at the first point of entry unless prior permission is received from The Canadian Food Inspection Agency (see FAL 1.2 for address).

A permit must be obtained from The Canadian Food Inspection Agency for all animals being transited through Canada (see FAL 1.2 for address).

Vaccinations are not required.

2.5 REGULATIONS CONCERNING THE IMPORTATION OF PLANTS AND ANIMALS

(a) *Endangered Species*

Regulations now prohibit the import or export of over 1 000 endangered species, as well as their recognizable parts and products, without proper permits. The following species and any articles made from them are only some of those which require permits: elephants (ivory); monkeys; all cats, except domestic; alligators; crocodiles; orchids; American cacti; falcons; and the larger sea turtles. For more information, contact the Administrator, Convention on International Trade in Endangered Species, Canadian Wildlife Service. (See FAL 1.2 for address).

(b) *Animals, birds, food and plants*

To guard against the introduction of foreign diseases or parasites into Canada, The Canadian Food Inspection Agency controls the admission of animals, birds, plants and products derived from them, such as meats. The regulations may change quickly as a result of epidemics in other parts of the world. For import regulations contact:

(i) *for animals:*

The Canadian Food Inspection Agency
Animal Health Division
59 Camelot Dr.
Nepean ON K1A 0Y9

Tel.: 613-225-2342, ext. 4629
Fax: 613 228-6630

(ii) *for plants, seeds, etc.:*

The Canadian Food Inspection Agency
Plant Health Division
59 Camelot Dr.
Nepean ON K1A 0Y9

Tel.: 613-225-2342, ext. 4334
Fax: 613-228-6605

- (c) The Canadian Food Inspection Agency has produced a brochure entitled *Don't Bring It Back* which gives the basic rules about agricultural items whose entry into Canada are controlled. It refers only to non-commercial items that might be brought to Canada for personal use. This pamphlet is available at the following website: <www.cfia-acia.agr.ca>

3.0 FEES AND CHARGES

3.1 AIRPORT FEES

The *Air Services Charges Regulations (ASCR)* contain the charges applicable at airports operated by or on behalf of the Department of Transport. An office consolidation of the ASCR is available on the Internet at <<http://laws.justice.gc.ca/eng/SOR-85-414/index.html>>. Changes to the ASCR are published in Parts I and II of the *Canada Gazette* available at <<http://www.gazette.gc.ca/>>

Charges for airport facilities and services not operated by the department should be obtained directly from each local airport authority.

Charges for en route facilities and services are available from NAV CANADA (see FAL 3.2).

3.2 AIR NAVIGATION SERVICE CHARGES (NAV CANADA)

NAV CANADA is Canada’s national provider of civil air navigation services (ANS). The air navigation system provides civil air navigation services to aircraft in Canadian sovereign airspace and international airspace for which Canada has air navigation services responsibility (“Canadian-controlled airspace”). These include air traffic control services, as well as aeronautical communication services, aeronautical information services, aviation weather services, emergency assistance services and flight information services. NAV CANADA charges for these services in accordance with the *Civil Air Navigation Services Commercialization Act*, S.C. 1996, c.20 (the ANS Act).

Described below are the categories of charges for air navigation services provided or made available by NAV CANADA or a person acting under the authority of the Minister of National Defence.

3.2.1 En-Route and Terminal Air Navigation Services

3.2.1.1 Annual Charges for Small Aircraft

Small Canadian-registered aircraft of three metric tons or less will be charged an annual fee that varies by aircraft weight. However, in the case of private aircraft used exclusively for non-business purposes, one annual fee applies regardless of the aircraft weight.

A quarterly fee equal to 25% of the above fee applies to foreign-registered aircraft.

3.2.1.2 Daily Charges for Propeller Aircraft Over Three Metric Tons (Including Helicopters and Small Jet Aircraft)

The daily fee applies to one or more departures at one or more aerodromes with air navigation services staffed by NAV CANADA personnel or by a person acting under the authority of the Minister of National Defence (towers, FSS). An aircraft operator also has the option of being charged the movement-based charge as set out in FAL

3.2.1.3 Movement-Based Charges for Jet Aircraft Over 3 Metric Tons

- (a) *En-route charge*: The charge is applied to flights in Canadian-controlled airspace excluding the Gander Oceanic FIR/CTA. The charge varies by aircraft weight and distance traveled.
- (b) *Terminal services charge*: The charge is applied on departures only from aerodromes with air navigation facilities staffed by either NAV CANADA personnel or by a person acting under the authority of the Minister of National Defence. This charge varies by aircraft weight.

3.2.2 Oceanic Services

3.2.2.1 NAT En-Route Facilities and Services Charge

This charge is for air navigation services provided or made available to an aircraft during the course of a flight in the Gander Oceanic FIR/CTA.

3.2.2.2 International Communication (Int’l Comm) Services Charge

This charge is for air-ground radio frequencies provided or made available to an aircraft during the course of an international flight, other than a flight between Canada and the continental United States, to obtain communication services.

NOTE: Differentiated Intn’l Comm service charges will become effective when position reporting via data link is accepted for operational purposes by NAV CANADA.

3.2.3 Customer Service and Account Inquiries

Any questions about service charges should be directed to a customer service representative:

Tel.: 1-800-876-4693-4
 (Disregard the last digit within North America)
 Fax: 613-563-3426
 E-mail: service@navcanada.ca
 Regular hours of operation: 0800–1800 (EST/EDT)

Details on the charges are available on NAV CANADA’s Web site <www.navcanada.ca>.



3.3 CHARGES FOR CUSTOMS SERVICES

At ICAO-designated international airports and all other airports authorized for customs clearance, customs inspection services are provided free of charge during Canada Customs and Revenue Agency (CCRA) authorized hours of service (see CFS for hours of operations). Hours of service vary by airport and are based on the need for local service, traffic volume, and seasonal demand.

Where the ETA is outside of CCRA authorized hours of service, customs service may not be guaranteed. On these occasions, prior to departure from a foreign airport, the owner or pilot shall communicate directly with CCRA at the airport by means of telephone or fax to ensure that customs services can be arranged. (Refer to the CFS for customs contact information.) For this purpose, contact should be made with customs officials during regular business hours.

Where customs inspection services are requested and arrangements are subsequently made for after-hours clearance, call-out charges will be levied for service outside the authorized published hours of service. These charges will apply for after-hour clearance on weekdays and at certain airports on Saturdays, Sundays and holidays.

These special call-out charges are assessed by specific costs such as the number of officers, the number of hours involved and the travel costs associated with the provision of customs inspection services.

3.4 PENALTIES FOR CUSTOMS VIOLATIONS

Since the law provides for substantial penalties for violations of the customs regulations, aircraft operators and pilots should make every effort to ensure compliance.

Failure to report to customs may result in penalties including forfeiture of the aircraft and any goods carried therein.

SAR – SEARCH AND RESCUE

1.0 RESPONSIBLE AUTHORITY

1.1 GENERAL

SAR service in Canada was established in accordance with the provisions of ICAO Annex 12. The Canadian Forces are responsible for conducting SAR operations for aeronautical incidents in Canada.

Aeronautical SAR service is provided through three joint rescue co-ordination centres (JRCC), located at Victoria, B.C., Trenton, Ont., and Halifax, N.S. The JRCCs control all rescue units in their region through an extensive civil/military communications network. The addresses of the JRCCs are:

VICTORIA

(serving British Columbia and the Yukon)

Joint Rescue Coordination Centre Victoria
P.O. Box 17000 Station Forces
Victoria BC V9A 7N2

Tel.: 1-800-567-5111 (within region)
..... 250-413-8933
..... #SAR or #727 (toll-free cellular)

TRENTON

(serving Alberta, Manitoba, Northwest Territories, western Nunavut, Ontario, western Quebec, Saskatchewan)

Joint Rescue Coordination Centre Trenton
P.O. Box 1000 Station Forces
Astra ON K0K 3W1

Tel.: 1-800-267-7270 (within Canada)
..... 613-965-3870

HALIFAX

(serving New Brunswick, Newfoundland and Labrador, Nova Scotia, eastern Nunavut, Prince Edward Island, eastern Quebec)

Joint Rescue Coordination Centre Halifax
P.O. Box 99000 Station Forces
Halifax NS B3K 5X5

Tel.: 1-800-565-1582 (within region)
..... 902-427-8200

NOTE: All JRCCs will accept collect telephone calls dealing with missing or overdue air or marine craft.

1.2 TYPES OF SERVICE AVAILABLE

Aeronautical SAR service is available continuously throughout Canada and the Canadian territorial coastal water areas of the Atlantic, Pacific and Arctic. Canadian Forces SAR units are equipped with helicopters and fixed-wing aircraft to conduct searches and provide rescue, including rescue specialists (search and rescue technicians) who are capable of parachuting into remote locations. These rescue personnel can render initial medical aid and provide emergency supplies and survival support. Volunteers of the Civil Air Search and Rescue Association (CASARA), organized in units across the country, assist the Canadian Forces with aeronautical SAR cases.

Workload permitting, JRCC personnel are prepared to present briefings on SAR services and techniques to the public and aviation groups on request. With prior notice, visits to JRCCs are encouraged.

Other major SAR providers in Canada include the Canadian Coast Guard, which has primary responsibility for marine incidents along Canada's ocean coasts, and in the waters of the Great Lakes St. Lawrence Seaway System. Provincial and territorial governments, usually through their police service, respond to SAR incidents involving persons on land, or on inland waterways. Parks Canada's Warden Service is responsible for ground or inland water SAR within National Parks. Across Canada, trained volunteers also play a key role in providing SAR services to the public. As mutual aid is one of the strengths of Canada's SAR system, the JRCCs may call upon any of these other providers, as well as the private sector, to assist with an aeronautical SAR case.

1.3 SAR AGREEMENTS

Two bilateral agreements relating to aeronautical SAR exist between Canada and the United States. The first permits public aircraft of either country that are engaged in aeronautical SAR operations to enter or leave the other country without being subject to normal immigration or customs formalities. The second agreement permits vessels and wrecking appliances of either country to render aid and assistance on specified border waters and on the shores and in the waters of the other country along the Atlantic and Pacific Coasts within a distance of 30 NM from the international boundary on those coasts.

In situations not covered by the agreements above, requests from the United States for aircraft of their own registry to participate in a SAR operation within Canada may be addressed to the nearest JRCC. The JRCC would reply and issue appropriate instructions.

Figure 1.1 – Search and Rescue Regions (SRR)

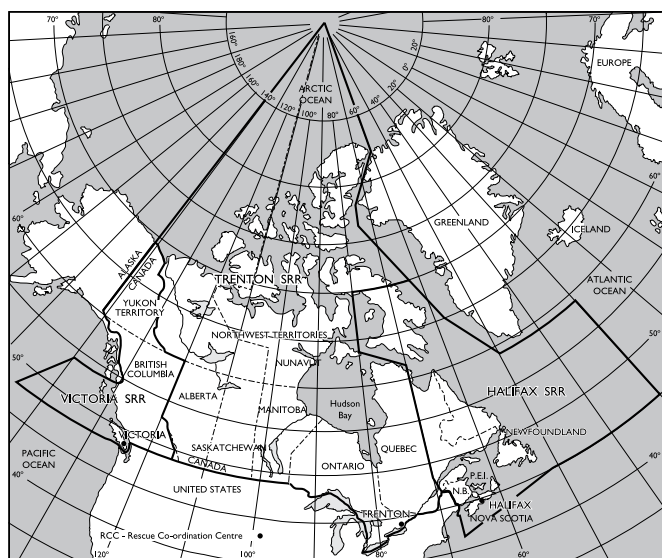

2.0 FLIGHT PLANNING

2.1 GENERAL

In addition to signals from ELTs, the flight plan and flight itinerary are the primary sources of information for SAR operations. Therefore, proper flight planning procedures must be followed and the filed routes adhered to in order to ensure early detection and rescue.

In Canada, the area covered in a visual search will typically extend to a maximum of 15 NM on either side of the flight-planned route, starting from the aircraft's last known position and extending to its destination. In mountainous regions, search areas will be defined to best suit the terrain and the planned route of flight. It is therefore critical to the safety of pilots that they maintain their route as planned, and advise ATS of any en route change or deviation as soon as practicable.

Refer to RAC 3.0 for details relating to filing and closing various plans or itineraries.

2.2 REQUEST FOR SAR ASSISTANCE

As soon as information is received that an aircraft is overdue, operators or owners should immediately alert the nearest JRCC or any ATS unit, giving all known details. The alerting call should not be delayed until after a small-scale private search. Such a delay could deprive those in need of urgent assistance at a time when it is most needed.

2.3 MANOT

When an aircraft is reported missing, the appropriate JRCC will issue a MANOT to the ATS units that are providing services in or near the search area. MANOTs will be communicated to pilots planning to overfly the search area by notices posted on flight information boards, orally during the filing of flight plans, or by radio communication.

Pilots receiving MANOTs are requested to maintain a thorough visual lookout and, insofar as it is practicable, a radio watch on 121.5 MHz when operating in the vicinity of the track the missing aircraft had planned to follow.

Once a MANOT has been issued, a major search effort will be initiated. Such an operation will be published in a NOTAM, and will involve a large number of military and civilian aircraft flying in a relatively confined area. Aircraft that are not participating in the search will be requested to keep a sharp lookout for other traffic, report any probable crash sightings to a FIC or JRCC, and remain clear of active search areas, if possible.

On termination of the search, another MANOT will be issued and designated as final.

SAR

INITIAL MANOT MESSAGE			
Required Information			Example
A.	MANOT number Type of MANOT	- SAR Operation - JRCC Responsible	A. MANOT six SAR-FSOX Initial-JRCC Victoria
B.	Type of Aircraft	- Registration - Colour	B. Cessna 180 C-FSOX red with white wings and black lettering
C.	Number of Crew and/or Passengers		C. Pilot, plus 3
D.	Route		D. Fort St. John to Abbotsford
E.	Departure Date/Time (local)		E. 1 May–10:00 PST
F.	LKP (last known position) Date/Time (local)		F. Prince George 1 May–11:31 PST
G.	Fuel Exhaust Time		G. Fuel exhaust time 1 May–15:00 PST
H.	Frequency of ELT		H. 121.5 MHz and 243 MHz

2.4 AIDING PERSONS IN DISTRESS

When a pilot observes an aircraft, ship or vessel in distress, the pilot shall, if possible:

- (a) keep the craft in sight until presence is no longer necessary;
- (b) report the following information to the JRCC or ATS unit:
 - (i) time of observation,
 - (ii) position of craft,
 - (iii) general description of scene, and
 - (iv) apparent physical condition of survivor(s).

NOTE: See SAR 4.9, *Canada Shipping Act* Extract, concerning the obligations of an aircraft to render assistance to ships or vessels in distress.

Pilots should be familiar with the distress signal that may be used by small boats. It consists of a rectangular, fluorescent orange-red cloth panel on which a black square and disc are displayed.

DISTRESS SIGNAL PANEL

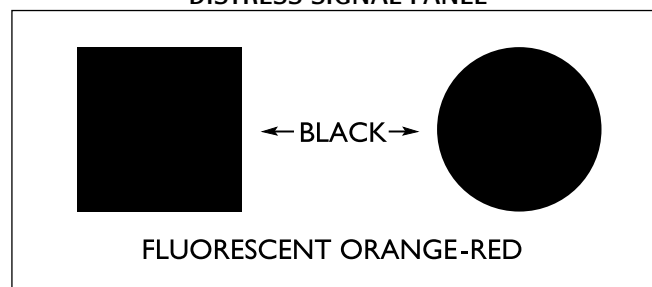

PROCEDURES FOR SIGNALING VESSELS

PROCEDURES PERFORMED IN SEQUENCE BY AN AIRCRAFT			SIGNIFICATION
<p>1. CIRCLE the vessel at least once.</p>	<p>2. CROSS the vessel's projected course close AHEAD at low altitude while ROCKING the wings. (See Note)</p>	<p>3. HEAD in the direction in which the vessel is to be directed.</p>	The aircraft is directing a vessel towards an aircraft or vessel in distress. (Repetition of such signals shall have the same meaning).
<p>4. CROSS the vessel's wake close ASTERN at low altitude while ROCKING the wings. (See Note)</p>			
<p>Note: Opening and closing the throttle or changing the propeller pitch may also be practiced as an alternative means of attracting attention to that of rocking the wings. However, this form of sound signal may be less effective than the visual signal of rocking the wings owing to high noise level on board the vessel.</p>			

3.0 EMERGENCY LOCATOR TRANSMITTER

3.1 GENERAL

ELTs are required for most general aviation aircraft (see CAR 605.38). They operate on a primary frequency of 121.5 MHz, 243 MHz, or 406 MHz, and help search crews locate downed aircraft and rescue survivors.

When activated, ELTs emit a signal that is detected by the international satellite system for search and rescue, COSPAS-SARSAT. Position information is calculated and relayed to the appropriate JRCC for action. The 121.5 MHz signal common to all ELTs also produces a distinctive siren-like tone that can be heard on a radio receiver tuned to this frequency. This signal helps incoming SAR responders pinpoint an aircraft's position. During routine operations, hearing a 121.5 MHz signal also alerts pilots to the inadvertent activation of their ELT. The frequency should therefore be monitored briefly after each flight.

Properly maintained ELTs with serviceable batteries should provide continuous operation for a minimum of 24 hr at a wide range of temperatures. Batteries that remain in service beyond their recommended life may not provide sufficient power to produce a usable signal. ELTs that contain outdated batteries are not considered to be serviceable.

All ELTs currently operating on 406, 121.5 and/or 243 MHz can be detected by COSPAS-SARSAT satellites. However, it is vital to note that effective February 1, 2009, COSPAS-SARSAT satellites will only detect 406 MHz ELT signals. After that date, a 406 MHz ELT will be required to ensure the COSPAS-SARSAT system is automatically notified in the event of an aircraft crash.

3.2 CATEGORIES OF ELT

There are five categories:

TYPE A or AD

- Automatic ejectable or automatic deployable: This type automatically ejects from the aircraft and is set in operation by inertia sensors when the aircraft is subjected to a crash deceleration force acting through the aircraft's flight axis. This type is expensive and is seldom used in general aviation.

TYPE F or AF

- Fixed (not ejectable) or automatic fixed: This type is automatically set in operation by an inertia switch when the aircraft is subjected to crash deceleration forces acting in the aircraft's flight axis. The transmitter can be manually activated or deactivated, and in some cases, may be remotely controlled from the cockpit. Provision

may also be made for recharging the batteries from the aircraft's electrical supply. An additional antenna may be provided for portable use of the ELT. Most general aviation aircraft use this ELT type, which must have the function switch placed to the "ARM" position for the unit to function automatically in a crash.

TYPE AP

- Automatic portable: This type is similar to Type F or AF, except that the antenna is integral to the unit for portable operation.

TYPE P

- Personal: This type has no fixed mounting and does not transmit automatically. A manual switch is used to start or stop the transmitter.

TYPE W or S

- Water-activated or survival: This type transmits automatically when immersed in water. It is waterproof, floats, and operates on the surface of the water. It has no fixed mounting. It should be tethered to survivors or life rafts.

3.3 INSTALLATION AND MAINTENANCE REQUIREMENTS

Installation of an ELT, as required by CAR 605.38, must comply with Chapter 551 of the *Airworthiness Manual*.

For maintenance, inspection, and test procedures, refer to CAR 605 and CAR 571.

3.4 ELT OPERATING INSTRUCTIONS (NORMAL USE)

Pre-flight

(Where practicable):

- inspect the ELT to ensure that it is secure, free of external corrosion, and that antenna connections are secure;
- ensure that the ELT function switch is in the "ARM" position;
- ensure that ELT batteries have not reached their expiry date; and
- listen to 121.5 MHz to ensure the ELT is not transmitting.

In-flight

Monitor 121.5 MHz when practicable. If an ELT signal is heard, notify the nearest ATS unit of:

- (a) position, altitude and time when signal was first heard;
- (b) ELT signal strength;
- (c) position, altitude and time when contact was lost; and
- (d) whether the ELT signal ceased suddenly or faded.

Pilots should not attempt a SAR operation. If unable to contact anyone, pilots should continue attempts to gain radio contact with an ATS unit, or land at the nearest suitable aerodrome where a telephone is located.

NOTE: If the signal remains constant, it may be your ELT.

Post-flight

Listen to 121.5 MHz. If an ELT is detected, and your ELT has not been switched to “OFF”, deactivate your ELT by switching it to “OFF”. For those ELT models that do not have an “OFF” switch, the unit should be disconnected and re-set as per the manufacturer’s instructions. If the tone ceases, notify the nearest ATS unit or JRCC of the time the signal was heard, and the time it was deactivated. If your ELT has been deactivated and you still hear an ELT on 121.5 MHz, it may not be your ELT. Notify the nearest ATS unit or JRCC.

3.5 ELT OPERATING INSTRUCTIONS (EMERGENCY USE)

The ELTs in general aviation aircraft contain a crash activation sensor, or G-switch, which is designed to detect the deceleration characteristics of a crash and automatically activate the transmitter. However, it is always safest to place the ELT function switch to “ON” as soon as possible after the crash, if practicable.

COSPAS-SARSAT satellites continually overfly Canada and will detect ELT signals within 90 min. In the case of aircraft equipped with a 406 MHz ELT, geostationary satellites (GEO) will detect the ELT within minutes, alerting the SAR system that there is an emergency, even while the final position is calculated.

Some military and commercial aircraft also monitor 121.5 MHz or 243 MHz and will notify ATS or SAR agencies of any ELT transmissions they hear.

In case of emergency, do not delay ELT activation until flight-planned times expire, as such delays will only delay rescue. Do not cycle the ELT through “OFF” and “ON” positions to preserve battery life, as irregular operation reduces localization accuracy and will hamper homing efforts. Once your ELT has been switched to “ON”, do not switch it “OFF”

until you have been positively located and directed to turn it off by the SAR forces.

If you have landed to wait out bad weather, or for some other non-emergency reason, and no emergency exists, do not activate your ELT. However, if the delay will extend beyond:

- (a) flight plan—1 hr past ETA; or
- (b) flight itinerary—the SAR time specified, or 24 hr after the duration of the flight, or the ETA specified;

your aircraft will be reported overdue, and a search will begin.

To avoid an unnecessary search, notify the nearest ATS unit of your changed flight plan or itinerary. If you cannot contact an ATS unit, attempt to contact another aircraft on one of the following frequencies in order to have that aircraft relay the information to ATS:

- (a) 126.7 MHz;
- (b) local VFR common frequency;
- (c) local ACC IFR frequency listed in the CFS;
- (d) 121.5 MHz; or
- (e) HF 5680 kHz, if so equipped.

If you cannot contact anyone, a search will begin at the times mentioned above. At the appropriate time, switch your ELT to “ON”, and leave it on until search crews locate you. Once located, use your aircraft radio on 121.5 MHz (turn the ELT off if there is interference) to advise the SAR crew of your condition and intentions. ELTs and the COSPAS-SARSAT system work together to speed rescue. The ELT “calls for help.” COSPAS-SARSAT hears that call, and promptly notifies SAR authorities, who then dispatch help. *Delays in activating your ELT will delay your rescue.*

3.6 MAXIMIZING THE SIGNAL

If the ELT is a portable model with its own auxiliary antenna, and can be safely removed from the aircraft, it should be placed as high as possible on a level surface to reduce obstructions between it and the horizon. Raising an ELT from ground level to 2.44 m (8 ft) may increase the range by 20 to 40 percent. The antenna should be vertical to ensure optimum radiation of the signal. Placing the transmitter on a piece of metal, or even the wing of the aircraft, if it is level, will provide the reflectivity to extend transmission range. Holding the transmitter close to the body in cold weather will not significantly increase battery power output. As the body will absorb most of the signal energy, such action could reduce the effective range of the transmission.

If the ELT is permanently mounted in the aircraft, ensure that it has not been damaged and is still connected to the antenna. If it is safe to do so (i.e. no spilled fuel or fuel vapours), confirm the ELT's operation by selecting 121.5 MHz on the aircraft radio and listening for the audible siren-like tone.

Reminder: The search will be conducted to locate the aircraft. If the aircraft lands in an uninhabited area, stay with the aircraft and the ELT. The aircraft is easier to see than people are. If possible, have smoke, flares or signal fires ready to attract the attention of search crews who are homing to the ELT. Smoke, flares and signal fires should be sited with due regard for any spilled fuel resulting from the crash.

3.7 ACCIDENTAL ELT TRANSMISSIONS

To forestall unnecessary SAR (UN SAR) missions, all accidental ELT activations should be reported to the nearest ATS unit, or the nearest JRCC, giving the location of the transmitter, and the time and duration of the accidental transmission. ELT alarms trigger considerable activity within ATS and SAR units. Although some accidental ELT transmissions can be resolved without launching SAR or Civil Air Search and Rescue Association (CASARA) aircraft, such as a properly-registered 406 MHz beacon, the JRCCs will adopt the safe course. Promptly notifying ATS or a JRCC of an accidental ELT transmission may prevent the unnecessary launch of a search aircraft. If they are promptly reported, there is no charge or penalty associated with the accidental triggering of an ELT.

3.8 TESTING PROCEDURES

When originally installed in an aircraft, and when parts of the ELT system are moved or changed, an ELT will be tested in accordance with CAR 571. Every few months, or as recommended by the manufacturer, pilots should test their ELT. Testing procedures for ELTs will vary depending upon the type.

406 MHz ELTs

Unlike traditional 121.5/243 MHz ELTs, 406 MHz ELTs and their associated cockpit remote switch should be tested in accordance with the manufacturer's instructions only. Since the digital signals from 406 MHz ELTs are detected almost immediately by COSPAS-SARSAT geostationary satellites (GEO), selection of the "ON" position for more than 50 s will result in an alert being routed directly to the JRCC, and interpreted as a real emergency.

All 406 MHz beacons are equipped with an integral self-test function, which also checks the power output of the 121.5 MHz transmitter. The manufacturer's documentation describes how to carry out this self-test and interpret its results, and should be followed closely to avoid false alerts.

121.5/243 MHz ELTs

Any testing of an ELT that operates only on 121.5 MHz or 243 MHz must only be conducted during the first 5 min of any UTC hour, and restricted in duration to not more than 5 s. Such tests can be done between two stations separated by at least half a kilometre, or by a single aircraft, using its own radio receiver.

(a) Two-station 121.5/243 MHz ELT test:

- (i) position the aircraft about one-half kilometre from the tower, FSS or other aircraft that will monitor 121.5 MHz. Ensure the listening station is clearly visible from the aircraft, as ELT transmissions are line-of-sight. Intervening obstacles, such as hills, buildings, or other aircraft, may prevent the listening station from detecting the ELT transmission.
- (ii) using the aircraft radio or other pre-arranged signals, establish contact with the listening station. When the listening station confirms that it is ready, switch the 121.5/243 MHz ELT function to "ON". After no more than 5 s, turn the ELT function switch to "OFF". The listening station should confirm that the ELT was heard.
- (iii) reset the ELT function switch to "ARM".
- (iv) tune the aircraft radios to 121.5 MHz to confirm that the ELT stopped transmitting.
- (v) if the listening station did not hear the ELT, investigate further before flying the aircraft.

When conducting the two-station test at a busy airport, take due regard of tower or FSS workload. Keep the voice radio transmissions to a minimum. If the "listening" station does not hear the ELT transmission, it may be necessary to move the aircraft to another location on the airfield to conduct the test.

It will often be impractical to co-ordinate a 121.5/243 MHz ELT test with a tower, FSS, or other aircraft. In such circumstances, pilots can use the following procedures to test their ELTs. Such tests are to be conducted in the first 5 min of any UTC hour, and test transmissions must be limited to 5 s or less.

(b) Single-station ELT test:

- (i) tune the aircraft radio receiver to 121.5 MHz.
- (ii) switch on the ELT just long enough to hear the tone, and immediately return the function switch to "ARM"; it is best to have another person in the cockpit to ensure the minimum "on-air" test period. Do not exceed the 5 s "on-air" time.
- (iii) recheck 121.5 MHz on the aircraft receiver to ensure that the ELT stopped transmitting.

When conducting a single aircraft test, it is possible that the aircraft radios will hear the ELT output, even though the ELT power transistor is defective, and will not be detected by a receiver half a kilometre away. However, this test will uncover a totally unserviceable ELT, and is better than no test.

Reminder: While all 406 MHz ELTs also transmit a 121.5 MHz homing signal, testing of 406 MHz ELTs must follow the manufacturer's instructions provided with the unit.

3.9 SCHEDULE OF REQUIREMENTS

The following schedule outlines the requirement to carry an ELT. Gliders, balloons, airships, ultralight aeroplanes and gyroplanes are exempt, as are aircraft operated by the holder of a flight training unit (FTU) operating certificate that are engaged in flight training, and operated within 25 NM of the departure aerodrome. Additional exemptions are contained in CAR 605.38.

If an ELT becomes unserviceable, the aircraft may be operated according to the operator's approved minimum equipment list (MEL), or where no MEL has been approved: for up to 30 days, provided the ELT is removed at the first aerodrome at which repairs or removal can be accomplished; the ELT is promptly sent to a maintenance facility; and a placard is displayed in the cockpit stating that the ELT has been removed, and the date of removal (see CAR 605.39).

Despite these exemptions, all pilots are reminded of the rugged, inhospitable terrain that covers much of Canada, and cautioned that, although some flights without ELTs may be legal, they are not advisable.

Column I	Column II	Column III
Aircraft	Area of Operation	Minimum Equipment
1. All aircraft except those exempted.	Over land	One ELT of type AD, AF, AP, A, or F.
2. Large multi-engine turbojet aeroplanes engaged in an air transport service carrying passengers.	Over water at a distance from land that requires the carriage of life raft pursuant to CAR 602.63.	Two ELTs of type W or S, or one of each.
3. All aircraft that require an ELT other than those set out in item 2.	Over water at a distance from land that requires the carriage of life raft pursuant to CAR 602.63.	One ELT of type W or S.

ELTs are designed to speed rescue to survivable crashes, and they should function automatically. However, if you are aware of their capabilities and limitations, you can improve the performance of your ELT, and thus assist SAR.

4.0 AIRCRAFT EMERGENCY ASSISTANCE

4.1 DECLARING AN EMERGENCY

An emergency condition is classified in accordance with the degree of danger or hazard being experienced, as follows:

Distress: A condition of being threatened by serious and/or imminent danger and requiring immediate assistance.

Urgency: A condition concerning the safety of an aircraft or other vehicle, or of some person on board or within sight, which does not require immediate assistance.

The radiotelephone distress signal MAYDAY and the radiotelephone urgency signal PAN PAN must be used at the commencement of the first distress and urgency communication, respectively, and, if considered necessary, at the commencement of any subsequent communication.

4.2 ACTION BY THE PILOT DURING EMERGENCY CONDITIONS

Pilots should:

- a) precede the distress or urgency message by the appropriate radiotelephone distress signal, preferably spoken 3 times;
- b) transmit on the air-to-ground frequency in use at the time;
- c) Include in the distress or urgency message as many as possible of the following elements:
 - (i) the name of the station addressed (time and circumstances permitting),
 - (ii) the identification of the aircraft,
 - (iii) the nature of the distress or urgency condition,
 - (iv) the intention of the person in command, and
 - (v) the present position, altitude or flight level, and heading.

NOTES 1: The above procedures do not preclude the possibility of the following courses of action:

- the pilot making use of any available frequency, or of broadcasting the message;
- the pilot using any means at his/her disposal to attract attention and make known his/her conditions;
- any person taking any means at his/her disposal to assist the emergency aircraft.

2: The station addressed will normally be that station communicating with the aircraft.

International emergency frequencies are 121.5 and 243.0 MHz. In Canada, 126.7 MHz should, whenever practicable, be continuously monitored in uncontrolled airspace. When aircraft are equipped with dual VHF equipment, it is strongly suggested that frequency 121.5 MHz be monitored at all times.

SAR

3: 121.5 MHz may also be used to establish communications when the aircraft is not equipped with the published frequencies or when equipment failure precludes the use of normal channels. See COM 5.11 for communicating with ATS on 121.5 MHz.

4.3 VHF DIRECTION-FINDING ASSISTANCE

The VHF direction-finding (VDF) system is covered in COM 3.10. VDF operating instructions are outlined in RAC 1.6.

4.4 TRANSPONDER ALERTING

If unable to establish communication immediately with an ATC unit, a pilot wishing to alert ATC to an emergency situation should adjust the transponder to reply on Mode A/3, Code 7700. Thereafter, communication with ATC should be established as soon as possible.

In the event of a communication failure, the transponder should be adjusted to reply on Mode A/3, Code 7600, to alert ATC to the situation. This action does not relieve the pilot of the requirement to comply with CAR 602.137, *Two-way Radiocommunication Failure in IFR Flight*.

In the event of unlawful interference (hijack), the transponder should be adjusted to reply to Mode A/3, Code 7500, to alert ATC to the situation (see RAC 1.9.8).

4.5 RADAR ALERTING MANOEUVRES

RAC 1.5.7 describes the radar assistance that is available through Canadian Forces facilities; however, when lost or in distress and unable to make radio contact, a pilot should attempt to alert *all available radar systems as follows*:

- a) squawk transponder code 7700 (emergency code);
- b) monitor emergency frequencies;
- c) fly two triangular patterns as depicted, resume course and repeat at five-minute intervals.

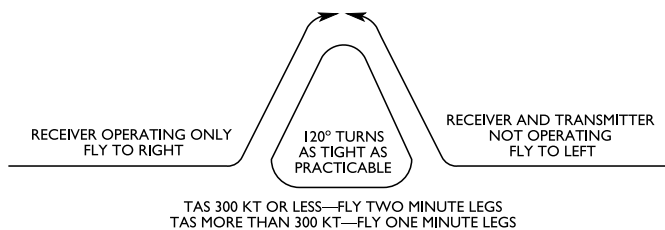

Since the greater the altitude of the aircraft, the better its chance of being detected, low-flying aircraft should attempt to climb. Also, if flying in limited visibility or at night, landing lights and navigation lights should be turned on to make it easier to be sighted.

Once radar contact is established, and if it is possible to do so, a rescue aircraft will be dispatched to intercept. Upon successful interception, the interceptor and distressed aircraft should attempt radio contact. If this is not possible, use the visual interception signals (see SAR 4.7). If, in a particular case, it is not possible for the Canadian Forces to send out an intercepting aircraft, flying of the triangular pattern will serve to position the distressed aircraft and thus narrow any search area.

Figure 4.1 – Canadian Radar Coverage Provided by NAV CANADA and DND

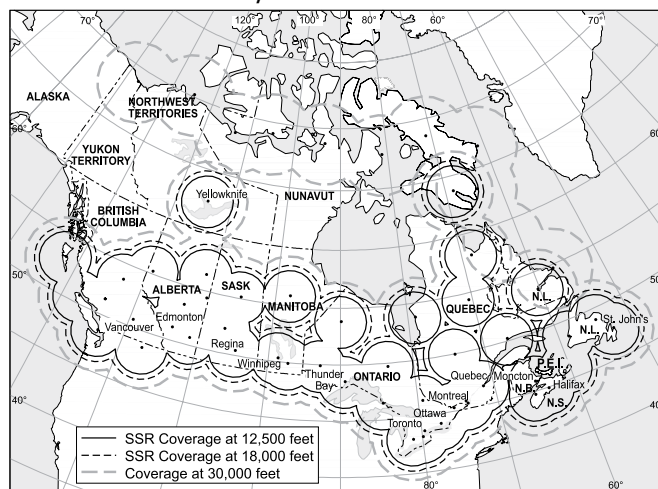

NOTE: The opportunity for an aircraft to be detected by radar, increases with altitude.

The map shows the area of radar coverage in Canada provided by both DND and NAV CANADA installations. Pilots should be aware that if they are flying in an area outside of radar coverage, flying a triangular pattern for alerting purposes would not be a valid manoeuvre.

4.6 EMERGENCY RADIO FREQUENCY CAPABILITY

Where an aircraft is required by the laws of Canada to install two-way VHF radio communication equipment, no person shall operate that aircraft unless the radio communication equipment is capable of providing communication on VHF aeronautical emergency frequency 121.5 MHz.

A person operating an aircraft within a sparsely settled area, or a Canadian aircraft over water at a horizontal distance of more than 50 NM from the nearest shoreline, should monitor continuously the VHF aeronautical emergency frequency 121.5 MHz unless:

- a) that person is carrying out communications on other VHF aeronautical frequencies; or
- b) aircraft electronic equipment limitations or essential cockpit duties do not permit simultaneous monitoring of the two VHF aeronautical frequencies.

4.7 INTERCEPTION PROCEDURES (CAR 602.144)

SCHEDULE I

PROCEDURES TO BE FOLLOWED IN THE EVENT OF INTERCEPTION

- (1) No person shall give an interception signal or an instruction to land except
 - a) a peace officer, an officer of a police authority or an officer of the Canadian Forces acting within the scope of their duties; or
 - b) a person authorized to do so by the Minister pursuant to subsection (2).
- (2) The Minister may authorize a person to give an interception signal or an instruction to land if such authorization is in the public interest and is not likely to affect aviation safety.
- (3) The pilot-in-command of an aircraft who receives an instruction to land from a person referred to in subsection (1) shall, subject to any direction received from an air traffic control unit, comply with the instruction.
- (4) The pilot-in-command of an intercepting aircraft and the pilot-in command of an intercepted aircraft shall comply with the rules of interception set out in the *Canada Flight Supplement* and repeated below.

The pilot-in-command of an aircraft intercepted by another aircraft shall immediately:

- a) follow the radio and visual instructions given by the intercepting aircraft, interpreting and responding to visual Signals in accordance with Schedule II;
- b) if possible, advise the appropriate air traffic services unit of the interception;
- c) attempt to establish radio communication with the intercepting aircraft by making a general call on aeronautical emergency frequency 121.5 MHz and, if practicable, on emergency frequency 243.0 MHz, giving the identity and position of the aircraft and the nature of the flight; and
- d) if equipped with a transponder, select Mode A Code 7700 unless otherwise instructed by the appropriate air traffic services unit.

Where any instructions received by radio from any source conflict with visual Signals received from the intercepting aircraft, the operator of the intercepted aircraft shall request immediate clarification from the intercepting aircraft or the appropriate air traffic services unit controlling the intercepting aircraft, while continuing to comply with the visual instructions received from the intercepting aircraft.

Where any instructions received by radio from any source conflict with those received by radio from the intercepting aircraft, the pilot-in-command of the intercepted aircraft shall request immediate clarification while continuing to comply with the radio instructions received from the intercepting aircraft.

SCHEDULE II

VISUAL SIGNALS FOR USE IN THE EVENT OF INTERCEPTION
Signals Initiated by Intercepting Aircraft and Response by Intercepted Aircraft

Series	Intercepting Aircraft Signal	Meaning	Intercepted Aircraft Response	Meaning
1.	<p>DAY—Rocking wings from a position in front and, normally, to the left of the intercepted aircraft, and after acknowledgement, a slow level turn, normally to the left, on to the desired heading.</p> <p>NIGHT—Same, and in addition, flashing navigational lights at irregular intervals.</p> <p>DAY or NIGHT— Meteorological conditions or terrain may require the intercepting aircraft to take up a position in front and to the right of the intercepted aircraft, and to make the subsequent turn to the right.</p> <p>If the intercepted aircraft is not able to keep pace with the intercepting aircraft, the latter is expected to fly a series of racetrack patterns and to rock its wings each time it passes the intercepted aircraft.</p> <p>DAY or NIGHT—Flares dispensed in immediate vicinity.</p>	<p>You have been intercepted. Follow me.</p>	<p>AEROPLANES: DAY—Rocking wings and following.</p> <p>NIGHT—Same, and in addition, flashing navigational lights at irregular intervals.</p> <p>HELICOPTERS: DAY or NIGHT—Rocking aircraft, flashing navigational lights at irregular intervals, and following.</p> <p>Same as above.</p>	<p>Understood; will comply.</p>
2.	<p>DAY or NIGHT—An abrupt breakaway manoeuvre from the intercepted aircraft, consisting of a climbing turn of 90 degrees or more, without crossing the line of flight of the intercepted aircraft.</p>	<p>You may proceed.</p>	<p>AEROPLANES: DAY or NIGHT—Rocking wings.</p> <p>HELICOPTERS: DAY or NIGHT—Rocking aircraft.</p>	<p>Understood; will comply.</p>
3.	<p>DAY—Circling aerodrome, lowering landing gear, and overflying runway in direction of landing or, if the intercepted aircraft is a helicopter, overflying the helicopter landing area.</p> <p>NIGHT—Same, and in addition, showing steady landing lights.</p>	<p>Land at this aerodrome.</p>	<p>AEROPLANES: DAY—Lowering landing gear, following the intercepting aircraft, and if, after over-flying the runway, landing is considered safe, proceeding to land.</p> <p>NIGHT—Same, and in addition, showing steady landing lights (if carried).</p> <p>HELICOPTERS: DAY or NIGHT— Following the intercepting aircraft and proceeding to land, showing a steady landing light (if carried).</p>	<p>Understood; will comply.</p>

SAR

Signals Initiated by Intercepted Aircraft and Response by Intercepting Aircraft

Series	Intercepted Aircraft Signal	Meaning	Intercepting Aircraft Response	Meaning
1.	AEROPLANES: DAY - Raising landing gear while passing over landing runway at a height exceeding 300 m (1,000 feet) but not exceeding 600 m (2,000 feet) above AAE, and continuing to circle the aerodrome.	Aerodrome you have designated is inadequate.	DAY or NIGHT - If it is desired that the intercepted aircraft follow the intercepting aircraft to an alternate aerodrome, the intercepting aircraft raises its landing gear and uses the Series 1 signals prescribed for intercepting aircraft.	Understood, follow me.
	NIGHT - Flashing landing lights while passing over landing runway at a height exceeding 300 m (1,000 feet) but not exceeding 600 m (2,000 feet) AAE, and continuing to circle the aerodrome. If unable to flash landing lights, flash any other lights available.		If it is decided to release the intercepted aircraft, the intercepting aircraft uses the Series 2 signals prescribed for intercepting aircraft.	Understood, you may proceed.
2.	AEROPLANES: DAY or NIGHT - Regular switching on and off of all available lights but in such a manner as to be distinct from flashing lights.	Cannot comply.	DAY or NIGHT - An abrupt breakaway manoeuvre from the intercepted aircraft consisting of a climbing turn of 90° or more without crossing the line of flight of the intercepted aircraft.	Understood.
3.	AEROPLANES: DAY or NIGHT - Irregular flashing of all available lights. HELICOPTERS: DAY or NIGHT - Irregular flashing of all available lights.	In distress.	DAY or NIGHT - An abrupt breakaway manoeuvre from the intercepted aircraft consisting of a climbing turn of 90° or more without crossing the line of flight of the intercepted aircraft.	Understood.

SAR

4.8 DOWNED AIRCRAFT PROCEDURES

4.8.1 Ground-to-Air Signals

Even if no ELT or distress signal has been received, a visual search will commence at the time indicated in the flight plan or flight itinerary. The search will typically extend up to 15 NM on either side of the flight-planned route, starting from the aircraft's last known position and concluding just beyond its destination. In mountainous regions, the search area will be defined to best suit the terrain and route of flight.

Some searches may last at least 24 hr before rescue is accomplished. Make the accident site as conspicuous as possible. Searchers will be looking for anything out of the ordinary, and their eyes will be drawn to any unnatural feature on the ground. The aircraft has the best chance of being spotted if large portions of its wings and tail are painted in vivid colours. Keep the aircraft cleared of snow.

As soon as possible after landing, and with due concern for spilled fuel or vapours, build a campfire. Collect a large pile of green material (e.g. tree boughs, fresh leaves, grasses) to quickly place on the fire, should an aircraft be seen or heard. Three signal fires forming a triangle is the standard distress signal, but even one large smoky fire should attract the attention of searchers.

One of the best high-visibility items now available on the market is a cloth panel of brilliant fluorescent colour, often referred to as a "conspicuity panel." It is staked to the ground during the day and used as a highly effective ground signal. It can also be used as a lean-to shelter and can supply some warmth as a blanket. Other means of attracting attention are reflecting sunlight using signal mirrors or shiny pieces of metal during daylight; or using flashlights, headlamps, strobes, or even camera flashes during hours of darkness.

The following symbols are to be used to communicate with aircraft when an emergency exists. Symbols 1 to 5 are internationally accepted; 6 to 9 are for use in Canada only.

NO.	MESSAGE	CORE SYMBOL
1.	REQUIRE ASSISTANCE	V
2.	REQUIRE MEDICAL ASSISTANCE	X
3.	NO or NEGATIVE	N
4.	YES or AFFIRMATIVE	Y
5.	PROCEEDING IN THE DIRECTION	↑
6.	ALL IS WELL	LL
7.	REQUIRE FOOD AND WATER	F
8.	REQUIRE FUEL AND OIL	L
9.	NEED REPAIRS	W

NOTE: Use strips of fabric or parachutes, pieces of wood, stones or any other available material to make the symbols.

Endeavour to provide as big a colour contrast as possible between the material used for the symbols and the background against which the symbols are exposed.

Symbols should be at least 8 ft in length or longer, if possible. Care should be taken to lay out symbols exactly as depicted to avoid confusion with other symbols.

A space of 10 ft should separate the elements of symbol 6.

4.8.2 Survival

Ability to assist the search can depend on the success of survival efforts. The emergency equipment detailed in CARs 602.61, 602.62 and 602.63 emphasizes being prepared for the geographical location and anticipated seasonal climatic variations.

If the aircraft lands in an uninhabited area, stay near the aircraft; the search is to locate the aircraft. Past experience has demonstrated that persons with a knowledge of survival techniques have saved their own and others' lives. Similarly, survivors invariably comment that a better knowledge of how to stay alive would have been invaluable.

There are several good books on survival skills widely available from bookstores and through the Internet.

The Emergency section of the CFS contains procedures to follow when sighting a downed aircraft, a ship in distress or when receiving an ELT signal

4.9 *Canada Shipping Act, 2001 (2001, C. 26) EXTRACT—PART 5, SECTIONS 130–133*

SEARCH AND RESCUE

Designation of rescue coordinators

130. (1) The Minister may designate persons as rescue coordinators to organize search and rescue operations.

Power of rescue coordinators

- (2) On being informed that a person, a vessel or an aircraft is in distress or is missing in Canadian waters or on the high seas off any of the coasts of Canada under circumstances that indicate that they may be in distress, a rescue coordinator may
- (a) direct all vessels within an area that the rescue coordinator specifies to report their positions;
 - (b) direct any vessel to take part in a search for that person, vessel or aircraft or to otherwise render assistance;
 - (c) give any other directions that the rescue coordinator considers necessary to carry out search and rescue operations for that person, vessel or aircraft; and
 - (d) use any lands if it is necessary to do so for the purpose of saving the life of a shipwrecked person.

Duty to comply

- (3) Every vessel or person on board a vessel in Canadian waters and every vessel or person on board a vessel in any waters that has a master who is a qualified person shall comply with a direction given to it or them under subsection (2).

Answering distress signal

131. (1) Subject to this section, the master of a vessel in Canadian waters and every qualified person who is the master of a vessel in any waters, on receiving a signal from any source that a person, a vessel or an aircraft is in distress, shall proceed with all speed to render assistance and shall, if possible, inform the persons in distress or the sender of the signal.

Distress signal—no assistance

- (2) If the master is unable or, in the special circumstances of the case, considers it unreasonable or unnecessary to proceed to the assistance of a person, a vessel or an aircraft in distress, the master is not required to proceed to their assistance and is to enter the reason in the official log book of the vessel.

Ships requisitioned

- (3) The master of any vessel in distress may requisition one or more of any vessels that answer the distress call to render assistance. The master of a requisitioned vessel in Canadian waters and every qualified person who is the master of a requisitioned vessel in any waters shall continue to proceed with all speed to render assistance to the vessel in distress.

Release from obligation

- (4) The master of a vessel shall be released from the obligation imposed by subsection (1) when the master learns that another vessel is complying with a requisition referred to in subsection (3).

Further release

- (5) The master of a vessel shall be released from an obligation imposed by subsection (1) or (3) if the master is informed by the persons in distress or by the master of another vessel that has reached those persons that assistance is no longer necessary.

Assistance

132. The master of a vessel in Canadian waters and every qualified person who is the master of a vessel in any waters shall render assistance to every person who is found at sea and in danger of being lost.

Aircraft treated as if vessel

133. Sections 130 to 132 apply in respect of aircraft on or over Canadian waters as they apply in respect of vessels in Canadian waters, with any modifications that the circumstances require.

MAP – AERONAUTICAL CHARTS AND PUBLICATIONS

2.0 AERONAUTICAL INFORMATION – VFR

1.0 GENERAL INFORMATION

1.1 GENERAL

Aeronautical information is divided into 2 categories. Firstly, that of a general preflight reference nature and, secondly, that used in preparing for specific flights and for navigation. For simplicity these 2 categories will be referred to as preflight reference information and inflight information.

1.2 PREFLIGHT REFERENCE INFORMATION

The preflight reference information is contained in the following publications:

- TC AIM (TP 14371E)
- AIP Canada (ICAO)*
- CARs (TP 12600E)
- DAH (TP 1820E)

The TC AIM is available to purchase or by subscription. A new edition is published every six months. Other publications can be purchased as detailed in MAP 7.0.

1.3 INFLIGHT INFORMATION

The inflight information is contained in the following publications:

- Canada Flight Supplement (CFS)*
- Canada Water Aerodrome Supplement (WAS)*
- Canada Air Pilot (CAP)*
- Enroute Charts
- Aeronautical Charts

The NOTAM system provides a means of disseminating temporary changes to the flight information advertised on aeronautical charts or in the associated flight information publications. It also provides a means of advising of permanent changes until such time as the charts can be amended (see MAP 5.0). The Voice Advisory System provides a means of disseminating frequently revised information of a local nature that may or may not require dissemination by other methods. The inflight information is divided into that intended for use in VFR operations and that intended for use in IFR operations.

2.1 GENERAL

In addition to the TC AIM and *AIP Canada (ICAO)*, VFR aeronautical information consists of VFR Navigation Charts (VNC), the VFR Terminal Area Charts (VTA) and the *Canada Flight Supplement (CFS)* or the *Canada Water Aerodrome Supplement (WAS)*. Information specific to the enroute portion of the flight is printed on the aeronautical charts. This includes:

- (a) topography;
- (b) hydrography;
- (c) aerodromes;
- (d) navigation aids;
- (e) airways and other controlled airspace; and
- (f) enroute hazards, such as:
 - (i) advisory areas,
 - (ii) restricted areas, and
 - (iii) obstructions.

Complete coverage of Canada is available in the VNC (1:500 000 scale) as indicated on the current Canadian Aeronautical Charts List. (See MAP 2.2)

Other aeronautical information required for use in VFR flight but not suitable for depiction on visual aeronautical charts, is published in the CFS. The CFS supports and complements the visual charts for all of Canada and some North Atlantic destinations, and includes:

- (a) a complete list of navigation aids associated with airport;
- (b) the current status of individual airports;
- (c) the availability of facilities and services at airports;
- (d) the telephone numbers for flight planning services; and
- (e) general procedural information.

The CFS includes aerodrome sketches.

To satisfy special operational requirements at certain high-density traffic airports with complex airspace structures, VTA Charts are available in a scale of 1:250 000. VTA Charts are produced for Vancouver, Edmonton/Calgary, Winnipeg, Toronto, Ottawa and Montréal.

2.2 INDEX TO CANADIAN AERONAUTICAL CHARTS

The index and list of current Canadian aeronautical charts (VNC and VTA) are now available at the following Web site: <http://www.navcanada.ca/> under “Aeronautical Information Products”.

This list is updated monthly. If you do not have access to the NAV CANADA Web site, you can still contact an authorized distributor. The list of authorized distributors appears in the “Planning” Section of the CFS.

2.3 UPDATING OF CANADIAN AERONAUTICAL CHARTS

Aeronautical charts are not revised on a fixed cyclic reproduction basis, although this is a long-term objective. At present, individual charts in each series are reviewed such that for charts covering the more densely populated areas, the topographic base maps are examined every 2 years and the aeronautical information is reviewed once a year. For areas outside the more densely populated areas, the topographic base maps are reviewed every 5 or 6 years and the aeronautical overlays are reviewed every 2 or 5 years, depending on the location in Canada. Charts identified as requiring updating during these inspections are then revised and reproduced.

2.4 CHART UPDATING DATA

The VFR Chart Updating Data section of the CFS provides a means of notifying VFR chart users of significant aeronautical information to update the current aeronautical charts. In this regard, significant aeronautical information is considered to be that which affects the safety of VFR operation, e.g., obstructions, restricted and advisory areas, blasting operations, cable crossings, and new or revised control zones. New or revised information of this nature, which is required to be depicted on visual charts, is advertised by NOTAM until such time as the information can be published in the VFR Chart Updating Data section of the CFS. Subsequently, the NOTAM is cancelled. Later, when any particular visual chart is being revised, any updating information from the VFR Chart Updating Data section of the CFS applicable to that chart is included on the chart and deleted from the CFS.

This system of moving significant VFR information from NOTAM to the VFR Chart Updating Data section of the CFS, and finally to the visual charts themselves, provides VFR operators with an aeronautical information service that is comprehensive, timely and easy to use. For pre-flight planning and in-flight navigation, VFR pilots should consult a current CFS and VNC that is appropriate to the intended route of flight. For flights into high density traffic areas, a current VTA should also be obtained. For pre-flight information, VFR pilots should reference a current copy of the TC AIM (TP 14371).

On receipt of the CFS, the pilot should check the VFR Chart Updating Data section for significant information that may update the particular charts being used. If the subscriber then consults the NOTAMs prior to departure, he/she will have obtained all essential aeronautical information that could affect the flight.

3.0 AERONAUTICAL INFORMATION – IFR

3.1 GENERAL

IFR aeronautical information consists of 2 “subpackages”: firstly, enroute information which is published on the *Low Altitude Enroute Charts* and the *High Altitude Enroute Charts*; and secondly, arrival and departure information which is published in the *Canada Air Pilot (CAP)* (7 volumes). The concept is that all operational information that is specifically pertinent to the conduct of the enroute portion of flight will be found on the Enroute Charts (airports, navigation aids, air routes, airways, minimum enroute altitudes, etc.). Aeronautical information that is specifically pertinent to the conduct of the arrival or departure portion of flight (instrument approach procedures, standard instrument departure procedures, and noise abatement procedures) is published in CAP.

In addition, *IFR Terminal Area Charts* are provided, depicting the terminal areas at the larger national airports. Terminal Area Charts are intended to assist in the transition from the enroute portion of the flight to the arrival portion, or from the departure portion to the enroute portion, at those terminals where the airspace structure is sufficiently complex to warrant the provision of a Terminal Area Chart. *IFR Terminal Area Charts* do not depict any aeronautical information that is not already depicted on the Enroute Charts or on the instrument approach procedure or departure procedure charts.

The Enroute Charts and CAP are supported and complemented by the *Canada Flight Supplement (CFS)*. It contains an aerodrome/facilities listing of all IFR airports, detailing the facilities and services available at these airports, as well as providing communications data, navigational facilities, radar data, and special notices and procedures. The CFS contains that IFR information required for use in flight, but not suitable for depiction on the Enroute Charts or for inclusion in CAP.

The various aeronautical information products have been designed to satisfy specific uses within the framework discussed above. An aeronautical information product intended for one purpose, should only be used for its intended purpose. A more detailed description of various IFR charts and publications is provided below.

3.2 EN-ROUTE PRODUCTS

(See reverse for Index)

3.2.1 Low Altitude

The *Low Enroute Altitude Charts, Canada and North Atlantic*, consisting of 10 charts (5 sheets back to back), are intended for use up to, but not including, 18 000 feet ASL within Canadian Domestic Airspace and that airspace over international waters and foreign territory in which Canada accepts responsibility for the provision of ATC services.

3.2.2 High Altitude

High Enroute Altitude Charts (HI) depict radio navigational aids and information, the high level airway system, special use airspace and communications station information critical for flight in the high level structure. Vertical coverage is from 18 000 feet ASL and above. The *High Enroute Altitude Charts* are printed back-to-back on three sheets and are revised every 56 days.

INDEX TO LOW ALTITUDE RADIO NAVIGATION CHARTS

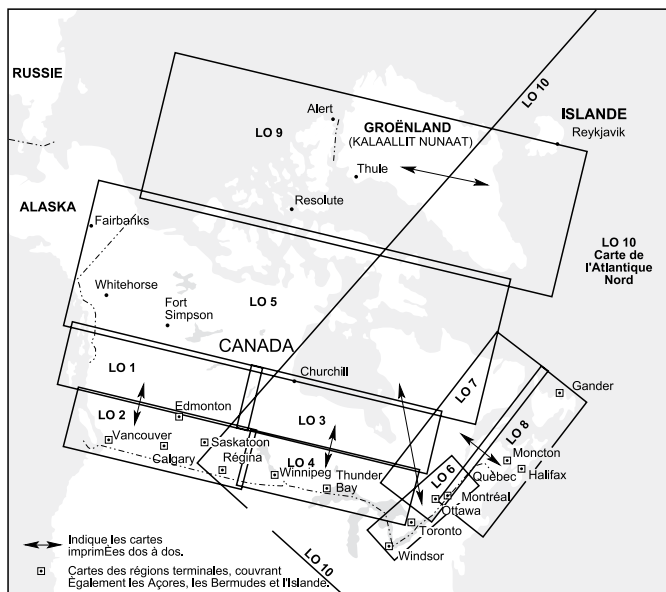

INDEX TO HIGH ALTITUDE RADIO NAVIGATION CHARTS



3.3 TERMINAL PRODUCTS

3.3.1 Terminal Area Charts

Nineteen Terminal Area Charts produced on a single sheet, back-to-back, are for use up to, but not including, 18 000 feet ASL within Canadian Domestic Airspace and that airspace over international waters and foreign territory in which Canada accepts responsibility for the provision of Air Traffic Control services. Charts of the Azores, Bermuda and Iceland are included for military use. The Radio Navigation Chart Index depicts the availability of Terminal Area Charts.

3.3.2 Terminal Instrument Procedures

Noise abatement procedures, standard instrument departure procedures and low altitude instrument approach procedures are published in CAP (7 volumes), and for military pilots, in GPH200 (4 volumes), which also contain high altitude instrument approach procedures.

MAP

3.4 CANADA FLIGHT SUPPLEMENT

The *Canada Flight Supplement* (CFS) as described in MAP 2.1 also supports and complements the Enroute Charts, approach plates, and lists all the navigation aids associated with the airports listed in the AERODROME/FACILITY DIRECTORY section. It is divided into the following six sections:

- A. General
- B. Aerodrome/Facility Directory
- C. Planning
- D. Radio Navigation and Communications
- E. Military Flight Data and Procedures
- F. Emergency

3.5 PUBLICATION REVISION CYCLES

The Enroute Charts, the IFR Terminal Area Charts, the Terminal Instrument Procedures, and the CFS, are revised every 56 days on dates consistent with the ICAO Air Information Regulation and Control (AIRAC) cycle. In the AIRAC system, planned changes to rules, procedures, facilities and services are programmed, to the extent practicable, to become effective on predetermined Thursdays at 56-day intervals.

All instrument approach procedures charts become effective on an AIRAC date, and the effective date is printed on the face of the chart. Revised charts are mailed at the latest by Thursday of the week previous to the Thursday effective date, which always allows at least a 7-day-in-transit period.

All current IFR charts and publications are updated by NOTAM. Use of outdated copies of IFR charts and/or publications is considered an extremely dangerous practice.

3.6 AERODROME OBSTACLE CHARTS – ICAO TYPE A

3.6.1 General

These charts have been prepared for selected airports used by operators of large aircraft and provide detailed information with regard to significant obstructions in the approach areas of runways. They are required for operational planning purposes. Only the charts listed are valid; other charts are being constantly updated. Please contact NAV CANADA for information on the most current charts.

3.6.2 Index of Aerodrome Obstacle Charts – ICAO Type A (Operating Limitations)

Charts are available from:

NAV CANADA
Aeronautical Publications
Sales and Distribution Unit
P.O. Box 9840 Station “T”
Ottawa ON K1G 6S8

Tel.: 1-866-731-PUBS (7827)
Fax: 1-866-740-9992
E-mail: aeropubs@navcanada.ca

NAV CANADA requires pre-payment for all orders. The price per chart is \$30.00 (Canadian) plus applicable taxes (no PST or GST payable on foreign orders). All orders are payable by cheque, money order or credit card.

AIRPORT	IDENT	RUNWAY	PRODUCT #	SURVEY DATE	EXPIRATION DATE	EDITION #
Calgary Intl.	CYYC	07/25	ICA0YYC07_25	Dec-09	Dec-14	2
		10/28	ICA0YYC10_28	Dec-09	Dec-14	2
		16/34	ICA0YYC16_34	Dec-09	Dec-14	2
Fredericton Intl.	CYFC	09/27	ICA0YFC09_27	Apr-07	Apr-12	1
Gander Intl.	CYQX	03/21	ICA0YQX03_21	Jan-09	Jan-14	2
		13/31	ICA0YQX13_31	Jan-09	Jan-14	2
Moncton Intl.	CYQM	11/29	ICA0YQM11_29	Jun-08	Jun-13	2
		06/24	ICA0YQM06_24	Jun-08	Jun-13	2
Montreal/Mirabel Intl.	CYMX	MX06_24	ICA0YMX06_24	Nov-07	Nov-12	2
		MX11_29	ICA0YMX11_29	Nov-07	Nov-12	2
Montreal/Pierre Elliott Trudeau Intl.	CYUL	06L/24R	ICA0YUL06L_24R	Nov-07	Nov-12	2
		06R/24L	ICA0YUL06R_24L	Nov-07	Nov-12	2
		10/28	ICA0YUL10_28	Nov-07	Nov-12	2
Québec City/Jean Lesage Intl.	CYQB	12/30	ICA0CYQB12_30	Nov-08	Nov-13	2
		06/24	ICA0CYQB06_24	Nov-08	Nov-13	2
St. John's Intl.	CYYT	11/29	ICA0YYT11_29	Apr-07	Apr-12	2
		13/34	ICA0YYT16_34	Apr-07	Apr-12	2
		06L/24R	ICA0YYZ06L_24R	Jul-08	Jul-13	2
Toronto/Lester B. Pearson Intl.	CYYZ	06R/24L	ICA0YYZ06R_24L	Jul-10	Jul-15	2
		15L/33R	ICA0YYZ15L_33R	Jul-07	Jul-12	2
		15R/33L	ICA0YYZ15R_33L	Jul-06	Jul-11	2
		05/23	ICA0YYZ05_23	Jul-09	Jul-14	2
Vancouver Intl.	CYVR	08L/26R	ICA0YVR08L_26R	Dec-07	Dec-12	2
		08R/26L	ICA0YVR08R_26L	Dec-07	Dec-12	2
Winnipeg Intl.	CYWG	13/31	ICA0YWG13_31	Sep-09	Sep-14	2
		18/36	ICA0YWG18_36	Sep-09	Sep-14	2

4.0 INFORMATION COLLECTION

4.1 RESPONSIBILITY

The Minister of Transport is responsible for the development and regulation of aeronautics and the supervision of all matters connected with aeronautics.

The responsibility for the collection, evaluation and dissemination of aeronautical information published in the *AIP Canada* (ICAO), *Canada Flight Supplement* (CFS), in the *Canada Water Aerodrome Supplement* (WAS), in the *Canada Air Pilot* (CAP) and in the aeronautical charts has been delegated by the Minister of Transport to NAV CANADA.

4.2 CORRECTION CARD SYSTEM

An important facet of the information collection system is the effective use by pilots of the correction cards that are enclosed with the various aeronautical information publications. Users should complete these cards with the information required on the back of the card. Alternatively, amendments may be reported to the appropriate regional office (See GEN 1.1 for addresses of Regional offices).

5.0 NOTAM

5.1 GENERAL

A NOTAM is a notice containing information concerning the establishment, condition or change in any aeronautical facility, service, procedure or hazard, the timely knowledge of which is essential to personnel concerned with flight operations. NOTAMs are distributed by teletype on the AFTN or by voice advisory using radio communications.

NOTAMs are a means of advertising changes to the information on aeronautical charts or in aeronautical information publications.

A NOTAM is originated and issued promptly whenever the information to be disseminated is of a temporary nature and of short duration, or when operationally significant permanent changes, or temporary changes of long duration are made at short notice, except for extensive text and/or graphics.

NOTE: Information of short duration containing extensive text and/or graphics is published as an *AIP Canada* (ICAO) Supplement (see MAP 6.2).

5.2 NOTAM DISTRIBUTION—CANADIAN

Canadian NOTAMs are distributed to FICs, FSSs and aircraft operators on the AFTN. The distribution is tailored to specific user requirements. Approximately 210 NOTAM files (four-letter Canadian location indicators) are resident in the domestic NOTAM database (see details in MAP 5.6.8). The first four characters of the NOTAM text further identify the aerodrome, the facility, the area of activity or the obstruction being advertised.

5.3 NOTAM DISTRIBUTION—INTERNATIONAL

Canadian NOTAMs for the CZQX, CZQM, CZUL and CZYZ FIRs requiring international distribution are issued under Series A. Canadian NOTAMs for the CZWG, CZEG and CZVR FIRs requiring international distribution are issued under Series B.

A monthly numerical checklist of current Canadian International NOTAMs is generated automatically on the first day of each month.

5.4 CRITERIA FOR ISSUING A NOTAM

Whenever possible, notification of conditions requiring the issue of a NOTAM will be distributed at least five hours in advance, but generally not more than 48 hours.

A NOTAM is originated and issued promptly to disseminate information concerning any of the conditions listed below:

- (a) establishment, closure or significant changes in operation of aerodrome(s) or runways;
- (b) establishment, withdrawal or significant changes in operation of aeronautical services (AGA, AIS, ATS, COM, MET, SAR, etc.);
- (c) establishment, withdrawal or significant changes in operational capability of radio navigation and air/ground communication services. This includes: interruption or return to operation, change of frequencies, change in notified hours of service, change of identification, change of orientation (directional aids), change of monitoring capability or location of any radio navigation and air/ground communication services;
- (d) establishment, withdrawal or significant changes made to visual aids;
- (e) interruption of or return to operation of major components of aerodrome lighting systems;
- (f) establishment, withdrawal or significant changes made to procedures for air navigation services;
- (g) occurrence or correction of major defects or impediments in the manoeuvring area;

- (h) changes to and limitations on availability of fuel, oil and oxygen;
- (i) major changes to search and rescue facilities and services available;
- (j) establishment, withdrawal or return to operation of hazard beacons marking obstacles to air navigation;
- (k) changes in regulations requiring immediate action, (example: *Designated Airspace Handbook* (TP 1820) amendments);
- (l) presence of hazards that affect air navigation (including obstacles, military exercises, displays, races, major parachuting events outside promulgated sites);
- (m) erection of, removal of, or changes to obstacles to air navigation in the takeoff/climb, missed approach, approach areas and runway strips;
- (n) establishment or discontinuance (including activation or deactivation), as applicable, or changes in the status of restricted, danger or advisory areas;
- (o) establishment or discontinuance of areas or routes or portions thereof;
- (p) allocation, cancellation or change of location indicators;
- (q) changes in the level of protection normally available at an aerodrome for rescue and fire fighting purposes;
- (r) outbreaks of epidemics necessitating changes in notified requirements for inoculations and quarantine measures;
- (s) forecasts of solar cosmic radiation, if provided;
- (t) operationally-significant change in volcanic activity;
- (u) release into the atmosphere of natural gas or toxic material; the location (to include radius and co-ordinates), altitude and direction of movement (if available);
- (v) establishment of operations of humanitarian relief missions, such as those undertaken under the auspices of the United Nations, together with procedures and/or limitations that affect air navigation;
- (w) implementation of short-term contingency measures in cases of disruption, or partial disruption, of air traffic services and related supporting services;
- (x) unavailability of meteorological data; or
- (y) other operationally-significant circumstances.

5.5 NOTAM SUMMARIES

Abbreviated plain language FIR summaries of all NOTAMs currently in effect are compiled and computer generated at predetermined times daily by the International NOTAM Office in Ottawa. These summaries, together with updating NOTAMs, provide current information for flight planning and for relay to en route traffic by the air-to-ground agencies when requested.

Four types of summaries are compiled as follows:

- (a) *FIR Summary*: An English summary containing an alphabetical listing of all valid NOTAM within that FIR.
- (b) *French (FR1)*: A French summary of all NOTAM from the Province of Quebec, the National Capital Region, Cornwall area (Ontario) and Northern New Brunswick.
- (c) *General (GEN)*: An English NOTAM summary of general interest to all users.
- (d) *General (GEN-FR2)*: A French NOTAM summary of general interest to users receiving French NOTAM.

NOTAMs in the FIR summaries are listed alphabetically by airport name or facility name and include items that would affect enroute flight and aerodromes. Information on volcanic eruptions would be found in the general portion of the FIR summary.

5.5.1 Summary Distribution Schedule

FIR summaries are issued daily as detailed below:

GANDER FIR/OCA.....	– 0430Z DAILY
MONCTON FIR.....	– 0530Z DAILY
MONTRÉAL FIR.....	– 0630Z DAILY
TORONTO FIR.....	– 0735Z DAILY
WINNIPEG FIR.....	– 0830Z DAILY
EDMONTON FIR NORTH OF 60N....	– 0930Z DAILY
EDMONTON FIR SOUTH OF 60N....	– 1030Z DAILY
VANCOUVER FIR.....	– 1130Z DAILY
SOMMAIRE FR1.....	– 0715Z DAILY–
SUMMARY GEN.....	– 0915Z AS REQUIRED
SOMMAIRE GEN FR2.....	– 1415Z AS REQUIRED

5.6 NOTAM FORMAT

5.6.1 General

5.6.1.1 Date-Time Group

Ten-digit date-time groups (YYMMDDHHMM) are used to depict the NOTAM start and end times. All NOTAMs—except cancelling NOTAMs and those amending data permanently—include a start and end date-time group. If the activity has started before the NOTAM is published, the start time will be the current time, that is, the time of the NOTAM dissemination. If the activity follows a certain schedule, the schedule will be inserted immediately before the start and end date-time groups.

5.6.1.2 NOTAM Time Schedule

A schedule is inserted only when the information contained in a NOTAM is occurring during specific periods within the overall “in force” period. The start of the first time period will correspond to the start date-time group and the end of the last period will correspond to the end date-time group, unless days are used and the NOTAM is in force for more than a week. The periods will be in chronological order. A date will appear only once.

5.6.2 New NOTAM (NOTAMN)

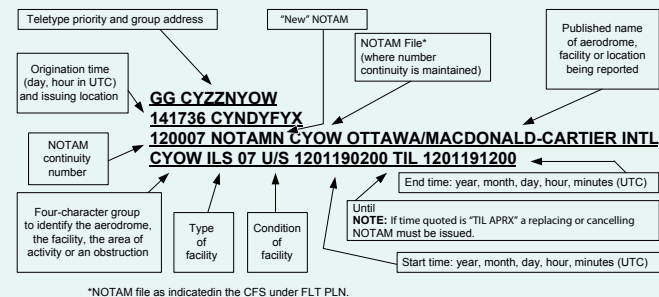

5.6.3 Replacing NOTAM (NOTAMR)



5.6.4 Cancelling NOTAM (NOTAMC)

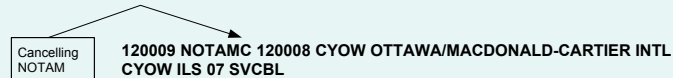

Some textual reference to the cancelled NOTAM is included for comparison with the original to ensure that it refers to the same subject.

5.6.5 Permanent Changes to Aeronautical Data

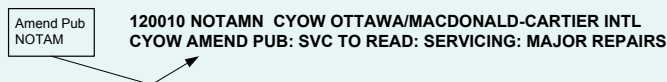

5.6.6 RSC/CRFI NOTAM (NOTAMJ)

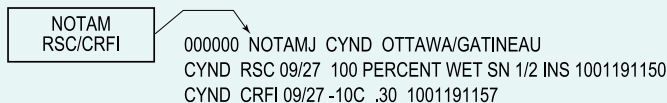

5.6.7 Query/Response NOTAM (NOTAMQ)

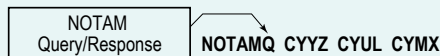

5.6.8 Automatic Query/Response—Canadian International NOTAM Database

Canadian NOTAMs, and NOTAMs from member States that distribute their NOTAMs to Canada, are available by automatic query/response to Canadian users. Limited non-Canadian NOTAM information is available to international users by query/response via the AFTN. These users will normally be the international NOTAM offices from member States.

Examples:

*GG CYZZQQNI
011845 EGGNYNYX
NOTAM CYA2541/10*

A maximum of four requests are permitted in one AFTN message.

5.6.9 Response Delivery

Should a user wish to direct a response to another teletype address or predetermined address indicator on the AFTN, the eight-letter address indicator must be added to the query/response format immediately following “NOTAMQ”.

Examples:

*GG CYZZQQNI
261855 EGGNYNYX
NOTAMQ EGZZOGXX A2541/98
GG CYZZQQNI
011947 RJAAYNYX
NOTAMQ RJZZNAXX A0125/98*

NOTE: States requiring additional information should contact the International NOTAM Office via:

NAV CANADA
International NOTAM Office
Combined ANS Facility
1601 Tom Roberts Avenue
PO Box 9824 Stn T
Ottawa ON K1G 6R2
Canada

AFTN: CYHQYNYX
Tel.: 613-248-4000
Fax: 613-248-4001
E-mail: notam@navcanada.ca

5.6.10 NOTAM Files

NOTAM files are four-character identifiers under which Canadian domestic NOTAMs are disseminated, stored and retrieved by electronic query/response. There are three categories of NOTAM files:

(a) *National NOTAMs:*

National NOTAMs are of general interest to all users. The national NOTAM file identifier is CYHQ.

(b) *FIR NOTAMs:*

- (i) any Class F airspace,
- (ii) any airspace restriction,
- (iii) military exercises,
- (iv) changes to published information for areas or routes,
- (v) ATS system change trial,
- (vi) volcanic activity,
- (vii) PAL frequencies, and
- (viii) en route RCO frequencies and navigation facilities not listed under a specific aerodrome in the Aerodrome/Facility Directory section of the CFS or WAS.

The FIR NOTAM file identifiers are CZVR, CZEG, CZWG, CZYZ, CZUL, CZQM and CZQX. FIR NOTAMs are not associated with a specific aerodrome and include information encompassing two or more sites within the same FIR. They also include:

NOTE: The airspace surrounding forest fires is defined by CARs 601.15 and 601.16 as restricted airspace. Therefore, NOTAMs on forest fires, as with any other airspace restriction, are filed under the appropriate FIR NOTAM file. In exceptional circumstances, the Minister may request that these NOTAMs be also issued under an aerodrome NOTAM file.

(c) *Aerodrome NOTAMs:*

With the exception of NOTAMs issued under the National NOTAM or appropriate FIR NOTAM file, as identified in the preceding sections, aerodrome NOTAMs describe information such as:

- (i) services,
- (ii) facilities,
- (iii) operations,
- (iv) hazards, and
- (v) activities of particular interest to a specific aerodrome, or within 25 NM of a specific aerodrome.

In the latter case, the NOTAMs are issued under the closest aerodrome. The Aerodrome NOTAM file identifiers are specified under the appropriate Flight Planning (FLT PLN) entry in the Aerodrome/Facility Directory of the CFS or WAS. An Aerodrome NOTAM file identifier can be used by more than one aerodrome.

NOTAMs for Arctic Radio RCO frequencies are issued under the CZNB NOTAM file identifier

NOTE: This type of information occurring beyond 25 NM of any aerodrome is issued under the appropriate FIR NOTAM file.

6.0 AIP CANADA (ICAO) SUPPLEMENTS, AERONAUTICAL INFORMATION CIRCULARS, AIRAC CANADA

6.1 GENERAL

AIP Canada (ICAO) Supplements and Aeronautical Information Circulars (AIC) are available for viewing or downloading on the NAV CANADA Web site. They may also be accessed via hyperlink from the Transport Canada TC AIM page on the Transport Canada Web site. AIP Canada (ICAO) Supplements and AICs will be cancelled, as required, throughout the year. A summary of current AIP Canada (ICAO) Supplements and AICs will be kept up-to-date on the NAV CANADA Web site.

6.2 AIP CANADA (ICAO) SUPPLEMENT

While permanent changes are published in the TC AIM and the AIP Canada (ICAO), temporary operational changes of long duration (three months or longer), as well as information of short duration that contains extensive text and/or graphics, will be published as AIP Canada (ICAO) Supplements. AIP Canada (ICAO) Supplements should not be used to duplicate information better contained in the TC AIM or the AIP Canada (ICAO).

6.3 AERONAUTICAL INFORMATION CIRCULAR

AICs provide advance notification of major changes to legislation, regulations, procedures or purely administrative matters where the text is not part of the TC AIM or AIP Canada (ICAO).

An AIC shall be issued whenever it is desirable to promulgate:

- (a) a long-term forecast of any major change in legislation, regulations, procedures or facilities;
- (b) information of a purely explanatory or advisory nature liable to affect flight safety;
- (c) information or notification of an explanatory or advisory nature concerning technical, legislative or purely administrative matters.

6.4 AIRAC CANADA

AIRAC Canada is a notice that is issued weekly by NAV CANADA, Aeronautical Information Services, to provide advance notification to chart makers and producers of aeronautical information concerning changes within the CDA. This notice ensures that all users of the Canadian airspace have the same information on the same date.

MAP

7.0 PROCUREMENT OF AERONAUTICAL CHARTS AND PUBLICATIONS

7.1 PUBLISHING AND DEPOSITORY SERVICES

The following publications are available from:

Publishing and Depository Services
 PWGSC
 Ottawa ON K1A 0S5
 Tel.: 1-800-635-7943 or 613-941-5995
 Fax: 1-800-565-7757 or 613-954-5779

	Catalogue No.	Price (1)(3)
Aircraft Technical Log: Section 1 – Airframe	T52-23-1-1987E	\$8.95
Section 2 – Record of Installations and Modifications to Aircraft	T52-2365-2	\$5.95
Section 4 – Propeller	T52-2365-4	\$7.95
Section 5 – Component	T52-2365-5	\$9.50
Designated Airspace Handbook (DAH)	TP 1820E	*
* Available free of charge, in digital format, on the internet at <www.navcanada.ca> under the heading of <i>Aeronautical Information Products</i> .		
Canadian Aviation Regulations (CARs) This publication can also be bought by part or subpart. Prices for a specific part or subpart are available from Canadian Government Publishing.	T51-15E	\$595.00

To order publications, forms, videos, CDs, DVDs, etc., to find out the status of a previously placed order, or to return a product or exchange a defective product, contact:

The Order Desk*

North America only: 1-888-830-4911
Local number: 613-991-4071
E-mail: MPS@tc.gc.ca
Fax: 613-991-2081
Internet: <www.tc.gc.ca>

- (1) Prices are subject to change without notice.
- (2) S/O: Standing Order – Amendments are sent automatically as they become available. The amendments must be paid upon receipt. Non-payment cancels the issuance of all future amendments.
- (3) The Goods and Services Tax (GST) of 5% must be added to the publication price.

A cheque or money order made payable to the Receiver General for Canada must accompany all orders.

Add 30% to the price of books being shipped outside Canada. All orders are to be paid in Canadian funds.

7.2 NAV CANADA

Individual purchases

Suggested retail price:

VNC, VTA	\$16.50/each
Enroute charts	\$6.00/each
Plastic wallet for charts	\$12.00/each
Canada Air Pilot	\$20.00/volume
[a copy of the CAP GEN is free with the purchase of one or more CAP volume(s)]	
Canada Flight Supplement	\$29.00/each
Canada Water Aerodrome Supplement	\$45.00/each

Individual aeronautical charts and publications can be obtained from a network of distributors and suppliers. They are listed on NAV CANADA's Aeronautical Publications, Sales and Distribution Unit Web site at <www.navcanada.ca> and in the *Canada Flight Supplement*, Section C. You can also call Aeronautical Publications at 1 866 731-PUBS (7827) for the distributor nearest you. Distributors may offer products at different prices.

7.2.1 Subscriptions

Subscriptions to the following charts and publications (except for the *Canada Water Aerodrome Supplement*) are for seven issues and are revised every 56 days:

Suggested retail price:

Enroute charts	\$12.00/each
Canada Air Pilot	\$45.00/volume
[CAP GEN publications are not re-issued every cycle, but are amended as required. A copy is free with the purchase of one or more CAP volume(s)]	
Canada Flight Supplement	\$99.00/each
Canada Water Aerodrome Supplement (issued once a year)	\$45.00/each

Subscription to the charts and publications above are available through NAV CANADA:

NAV CANADA
Aeronautical Publications Sales and Distribution Unit
P.O. Box 9840 Station T
Ottawa ON K1G 6S8
Tel. (toll free): 1-866-731-PUBS (7827)
Fax (toll free): 1-866-740-9992
Fax (local): 613-744-7120
E-mail: aeropubs@navcanada.ca
Web site: <www.navcanada.ca>
Online Store: http://products.navcanada.ca

Prices are subject to change without notice; taxes are not included. Handling charges of \$30.00 for Canada and \$35.00 for other countries are added to each subscription order and renewal. Visa, MasterCard and American Express are accepted. All sales are final. Please allow 10 days for delivery of your initial issue. If your subscription has not arrived three days before the effective date, please call NAV CANADA's Aeronautical Publications, Sales and Distribution Unit.

For product information, please call 1-866-731-PUBS (7827) or visit NAV CANADA's Aeronautical Publications Web site at <www.navcanada.ca> or e-mail us at <aeropubs@navcanada.ca>.

MAP

8.0 CHARTS AND PUBLICATIONS FOR INTERNATIONAL FLIGHTS

8.1 GENERAL

Foreign air rules, procedures and customs requirements may be different from those applicable in Canada. Failure to comply with foreign customs requirements may cause unnecessary delay and embarrassment. Failure to comply with foreign air rules and procedures may cause a near miss or an accident. Therefore, pilots who are planning flights to other countries must ensure they obtain the required current aeronautical information for each country to be visited.

Most countries publish a State AIP, as well as aeronautical charts and publications similar to those used in Canada. For the address from which aeronautical information for foreign states may be obtained, refer to ICAO Doc 7383-AIS/503/87, entitled *Aeronautical Information Services Provided By States*. To obtain this document, you may contact:

Document Sales Unit
International Civil Aviation Organization
999 University Street
Montreal QC H3C 5H7
Tel.:514-954-8022
Fax:514-954-6769
e-mail: *sales_unit@icao.int*

LRA – LICENSING, REGISTRATION AND AIRWORTHINESS

1.0 FLIGHT CREW LICENSING

1.1 GENERAL

The *Aeronautics Act* (AA) and *Canadian Aviation Regulations* (CARs) contain Canadian aeronautics legislation, regulations and standards for flight crew licensing.

NOTES 1: The information provided in this section is intended as a guide only. Contact a Transport Canada regional licensing office for specific concerns.

2: In the event of a discrepancy between the information found in this section and the *Canadian Aviation Regulations* (CARs), the CARs shall take precedence.

The CARs or any Bilateral Flight Crew Licensing Agreement with an International Civil Aviation Organization (ICAO) contracting State, contain complete licensing requirements and specific details for individual permits, licences, ratings and medical requirements. Flight crew licensing regulations and standards are found in:

- a) Part IV— CAR 401 and 421, *Flight Crew Permits, Licences and Ratings*;
- b) Part IV— CAR 404 and 424, *Medical Requirements*; or
- c) Bilateral Flight Crew Licensing Agreement.

Permits, licences and medical certificates, in the form of labels, are attached into an Aviation Document Booklet provided to flight crew members as evidence that they are qualified for certain aviation-related permits, licences and ratings. The booklet includes the holder's photograph and other security features for positive authentication:

- a) Licences conform to the standards set forth in Annex 1 to the ICAO *Convention on International Civil Aviation*, signed in Chicago, on December 7, 1944. All Canadian differences to ICAO Standards are published in this chapter.
- b) Permits do not conform to ICAO standards and are valid only in Canadian airspace, unless authorized by the country in which the flight is conducted.
- c) The CARs require that for the issuance of a licence or permit, all applicants must submit a passport-style photograph with their application. The photograph must be submitted with the *Application for Aviation Document Booklet*.

Permit or licence holders must hold a *Restricted Operator Certificate* with Aeronautical qualification (ROC-A) in accordance with the requirements of Industry Canada, if they are going to operate radiotelephone equipment on board aircraft.

1.2 AVIATION DOCUMENT BOOKLET

An applicant must apply for an *Aviation Document Booklet* with their first Canadian permit or licence application.

The 24-page booklet is divided into three sections: Licence and Permit, Competency Record, and Medical Certification. The booklet allows for multiple renewals of licences, permits and medical certificates throughout its validity period. More information on the booklet can be found on the following TCCA Web site: <www.tc.gc.ca/eng/civilaviation/standards/general-personnel-changes-3419.htm>.

The booklet will be valid for five years, in accordance with the provisions of CAR 401.12(4).

1.3 AVIATION LANGUAGE PROFICIENCY

All flight crew licences are required by ICAO to be annotated with a language proficiency rating indicating that licence holders are proficient in conducting and comprehending radiotelephony communications in English or the language used for aviation communications between aircraft and ground stations worldwide.

TCCA annotates flight crew licences to indicate English or French or both, showing that the holder has met the requirements for aviation language proficiency, provided that the applicant has been assessed at an “Expert” or “Operational” level.

- (a) “Expert” level corresponds to ICAO Level 6.
 - (i) The “Expert” level is non-expiring, and requires no further testing for the licence holder.
- (b) “Operational” level corresponds to ICAO Levels 4 and 5.
 - (i) The “Operational” level is the minimum required proficiency level for radiotelephony communication, and the licence holder must be re-tested every 5 years.

Those assessed at “Below Operational” level (ICAO Levels 1-3) do not qualify for a Canadian flight crew licence.

1.4 PERMITS AND LICENCES ISSUED BY TRANSPORT CANADA CIVIL AVIATION (TCCA)

1.4.1 Permits

- (a) Student Pilot Permit
- (b) Gyroplane Pilot Permit
- (c) Ultra-light Permit
- (d) Recreational Permit–Aeroplane

1.4.2 Licences

- (a) Glider Pilot Licence
- (b) Balloon Licence
- (c) Private Pilot Licence–Aeroplane
- (d) Private Pilot Licence–Helicopter
- (e) Commercial Pilot Licence–Aeroplane
- (f) Commercial Pilot Licence–Helicopter
- (g) Airline Transport Pilot Licence–Aeroplane
- (h) Multi-crew Pilot Licence–Aeroplane
- (i) Airline Transport Pilot Licence–Helicopter
- (j) Flight Engineer Licence

NOTE: The qualifications relating to Aircraft Maintenance Engineers (AME) and Air Traffic Controllers (ATC) are outlined in the CARs:

- (a) CAR 402 and 422, Air Traffic Controller Licences and Ratings
- (b) CAR 566, Aircraft Maintenance Engineer Licensing

1.5 DEFINITIONS OF FLIGHT EXPERIENCE

- 1) The following definitions apply:
 - (a) **dual** is the flight time during which a person is receiving flight instruction from a person qualified in accordance with the CARs.
 - (b) **solo** is the flight time necessary to acquire a flight permit, licence or rating:
 - i. in the case of a pilot, the flight time during which the pilot is the sole flight crew member, and

- ii. in the case of a student pilot permit holder, the flight time during which the holder is the sole occupant of an aircraft while under the direction and supervision of the holder of a flight instructor rating for the appropriate category of aircraft.
- (c) **pilot-in-command (PIC)**, in relation to an aircraft, is the pilot having responsibility and authority for the operation and safety of the aircraft during flight time.
- (d) **co-pilot** is the pilot who is assigned co-pilot duties during flight time:
 - i. in an aircraft certified to be operated by two crew in accordance with the CARs, or
 - ii. in an aircraft certified for single pilot operations and required to be operated with a co-pilot, according to the Private Operators Certificate or Air Operator's Certificate in accordance with Subpart 604 or Part VII of the CARs, or
 - iii. under a TCCA-approved pilot training program, while acting as pilot-in-command under supervision in accordance with section 421.11 of the CAR Standard (pilot-in-command under supervision [PIC U/S]: <www.tc.gc.ca/eng/civilaviation/regserv/cars/part4-standards-421-1086.htm#421_11>.
- (e) **instrument flight time** is any flight time in an aircraft, in the air, while piloting the aircraft by sole reference to the flight instruments.
 - i. This flight time can be accumulated while operating under instrument flight rules (IFR), instrument meteorological conditions (IMC), or visual meteorological conditions (VMC) during flight training while under a hood, while wearing limited vision goggles, or by other means which limit the pilots visibility outside the cockpit environment.
- (f) **instrument ground time** is instrument time in a simulator or a flight training device (FTD) approved by TCCA for flight training purposes, while controlling the simulator or FTD by sole reference to the flight instruments.

NOTE: Every holder of a flight crew permit, licence or rating OR every applicant for a flight crew permit, licence or rating, shall maintain a personal log in accordance with section 401.08 of the CARs: <www.tc.gc.ca/eng/civilaviation/regserv/cars/part4-401-1073.htm#401_08>.

1.6 SUMMARY OF REQUIREMENTS FOR PERMITS

The following tables summarize the licensing and medical fitness requirements for all flight crew permits and licences. For more information, refer to CAR 421-*Flight Crew Permits, Licences and Ratings*.

1.6.1 Student Pilot Permits

STUDENT PILOT PERMIT CATEGORY	AGE	MEDICAL CATEGORY	VALIDITY PERIOD	KNOWLEDGE	EXPERIENCE (Minimum Hours)	SKILL
Gyroplane	14	1 or 3	60 months	PSTAR 90%	As per skill	Certified ready for solo
Ultra-light Aeroplane	14	1, 3 or 4	60 months	In accordance with CAR 421.19(2)(d)(i)	As per skill	Certified ready for solo
Glider	14	1, 3 or 4	60 months	In accordance with CAR 421.19(2)(d)(ii)	As per skill	Certified ready for solo
Balloon	14	1 or 3	60 months	PSTAR 90%	As per skill	Certified ready for solo
Aeroplane	14	1, 3 or 4*	60 months	PSTAR 90%	As per skill	Certified ready for solo
Helicopter	14	1 or 3	60 months	PSTAR 90%	As per skill	Certified ready for solo

NOTE: * When used for the Student Pilot Permit-Aeroplane, the Category 4 Medical Declaration must be signed by a physician licensed to practice in Canada.

1.6.2 Pilot Permits

PERMIT CATEGORY	AGE	MEDICAL CATEGORY	VALIDITY PERIOD (Age 40 and over)	KNOWLEDGE	EXPERIENCE (Minimum Hours)	SKILL
Gyroplane	17	1 or 3	60 months (24 months)	40 hr. ground school GYROP 60%	Total: 45 Total dual: 12 Total solo: 12	Flight demonstration Letter from instructor
Ultra-light Aeroplane	16	1, 3 or 4	60 months (60 months)	Ground School ULTRA 60%	Total: 10 Dual: 5 Solo: 2	Flight demonstration Letter from instructor
Recreational-Aeroplane	16	1, 3 or 4*	60 months (24 months)	No ground school RPPAE 60% (may elect to write the PPAER exam)	Total: 25 Dual: 15 Solo: 5	Flight test

NOTE: * When used for the Recreational Pilot Permit-Aeroplane category, the Category 4 Medical Declaration must be signed by a physician licensed to practice in Canada.



1.7 SUMMARY OF REQUIREMENTS FOR LICENCES

1.7.1 Pilot Licence

LICENCE CATEGORY	AGE	MEDICAL CATEGORY	VALIDITY PERIOD (Age 40 and over)	KNOWLEDGE	EXPERIENCE (Minimum Hours)	SKILL
Glider	16	1, 3 or 4	60 months (60 months)	15 hr ground school GLIDE 60%	Total: 6 Dual: 1 Solo: 2	Flight demonstration Letter from instructor
Balloon	17	1 or 3	60 months (24 months)	10 hr ground school PIBAL 60%	Total: 16 Untethered: 11 Dual: 3 Solo: 1	Flight demonstration Letter from instructor

1.7.2 Private Pilot Licence (PPL)

LICENCE CATEGORY	AGE	MEDICAL CATEGORY	VALIDITY PERIOD (Age 40 and over)	KNOWLEDGE	EXPERIENCE (Minimum Hours)	SKILL
Private Pilot-Aeroplane (PPL-A)	17	1 or 3	60 months (24 months)	40 hr. ground school PPAER 60%	Total: 45 Dual: 17 Solo: 12	Flight test
Private Pilot-Helicopter (PPL-H)	17	1 or 3	60 months (24 months)	40 hr. ground school PHEL 60%	Total: 45 Dual: 17 Solo: 12	Flight test

1.7.3 Commercial Pilot Licence (CPL)

LICENCE CATEGORY	AGE	MEDICAL CATEGORY	VALIDITY PERIOD (Age 40 and over)	KNOWLEDGE	EXPERIENCE (Minimum Hours)	SKILL
Commercial Pilot-Aeroplane (CPL-A)	18	1	12 months (6 months)	80 hr ground school CPAER 60%	Total: 200 PIC: 100 Following the issue of PPL-A: 65 hr Commercial flight training Total dual: 35 Total solo: 30	Flight test
Commercial Pilot Helicopter (CPL-H) (PPL - H Held)	18	1	12 months (6 months)	40 hr ground school CPHEL 60%	Total: 100 PIC: 35 Additionally following the issue of PPL: 60 hr commercial flight training Total dual: 37 Total solo: 23	Flight test
Commercial Pilot-Helicopter (CPL-H) (No PPL - H Held)	18	1	12 months (6 months)	80 hr Ground school CPHEL 60%	Total: 100 PIC: 35 No PPL-H held: 100 hr Commercial flight training Dual: 55 Solo: 35	Flight test

1.7.4 Airline Transport Pilot Licence (ATPL)

LICENCE CATEGORY	AGE	MEDICAL CATEGORY	VALIDITY PERIOD (Age 40 and over)	KNOWLEDGE	EXPERIENCE (Minimum Hours)	SKILL
Airline Transport Pilot -Aeroplane (ATPL-A)	21	1	12 months (6 months)	SAMRA 70% SARON 70% INRAT 70%	Total: 1 500 Aeroplane Total: 900 PIC: 250	Flight test for a Group 1 Instrument Rating
Airline Transport Pilot -Helicopter (ATPL-H)	21	1	12 months (6 months)	HAMRA 70% HARON 70%	Total: 1 000 Helicopter Total: 600 PIC: 250	Flight test on a two-crew helicopter

1.7.5 Multi-Crew Pilot Licence (MPL)

LICENCE CATEGORY	AGE	MEDICAL CATEGORY	VALIDITY PERIOD (Age 60 and over)	KNOWLEDGE	EXPERIENCE (Minimum Hours)	SKILL
Multi-crew Pilot (MPL)	18	1	12 months (6 months)	MPGEN 70% MPINS 70% MPFLT 70%	Total: 230 Aeroplane Total: 40 PIC: 10 Approved training program	Pilot Proficiency Check (PPC) on a two-crew aircraft

LRA

1.7.6 Flight Engineer Licence

LICENCE CATEGORY	AGE	MEDICAL CATEGORY	VALIDITY PERIOD (Age 40 and over)	KNOWLEDGE	EXPERIENCE (Minimum Hours)	SKILL
Flight Engineer	18	1	12 months (6 months)	FLENG 60%	Total: 100	Flight demonstration Letter from instructor
Flight Engineer (Holds a CPL-A)	18	1	12 months (6 months)	FLENG 60%	Total: 50 Approved training program	Flight demonstration Letter from instructor

1.8 LICENCE DIFFERENCES WITH ICAO STANDARDS AND RECOMMENDED PRACTICES

1.8.1 General Rules Concerning Licences (Chapter 1)

ICAO PROVISION	DETAILS OF DIFFERENCE
Chapter 1, Paragraph 1.2, Note 2 a)	Canada does not issue flight navigator licences.
Chapter 1, Paragraph 1.2, Note 2 b)	Canada does not issue flight operations officer/flight dispatcher or aeronautical station operator licences.
Chapter 1, Paragraph 1.2.4, Note 2	Canada issues Category 1, 2, 3 and 4 medical certificates to satisfy licensing requirements of medical fitness.
Chapter 1, Paragraph 1.2.4.1	Canada issues the following medical certificates: <ul style="list-style-type: none"> • Category 1–equivalent to ICAO Class 1 Medical Assessment. Includes flight engineer licence. • Category 2– equivalent to ICAO Class 3 Medical Assessment. • Category 3–equivalent to ICAO Class 2 Medical Assessment. Excludes flight engineer licence and glider pilot licence. • Category 4–non-ICAO, valid only in Canadian Airspace. Applies to: glider pilot licences, recreational pilot permits, and ultra-light aeroplane permits.
Chapter 1, Paragraph 1.2.4.3	Canada calculates the period of validity of a Medical Assessment from the first day of the month following the date the medical examination was performed. (For example, medical examination done on June 13 will have the validity period calculated from July 1.)
Chapter 1, Paragraph 1.2.4.3.1	Canada may extend the period of validity of a Medical Assessment up to 60 days.
Chapter 1, Paragraph 1.2.5.2	Canada has determined the period of validity of a Medical Assessment for the holder of an Air Traffic Controller Licence to be not greater than 24 months.
Chapter 1, Paragraph 1.2.9.4 (Appendix 1, Attachment A)	Canada annotates the holder's licence with a language proficiency rating in English or French or both, provided that the applicant has been assessed at an "Expert" or "Operational" level. <ul style="list-style-type: none"> • "Expert" level corresponds to ICAO Level 6, which requires no further testing. • "Operational" level corresponds to ICAO Levels 4 and 5, which must be re-tested every 5 years.

1.8.2 Licences and Ratings for Pilots (Chapter 2)

ICAO PROVISION	DETAILS OF DIFFERENCE
Chapter 2, Paragraph 2.1.3.1.1 (Recommended practice)	Canada does not have a class rating for helicopters.
Chapter 2, Paragraph 2.1.10	Canada does not restrict the privileges of pilots who have attained their 60 birthday or curtail the privileges of pilots who have attained their 65 birthday.
Chapter 2, Paragraph 2.3.3.1.1 and 2.3.4.1.1	Canada requires applicants for a PPL to complete not less than 45 hr flight time, of which 5 hr must be instrument time.
Chapter 2, Paragraph 2.4.3.1.1.1 c) and 2.4.4.1.1.1 c)	Canada requires applicants for a CPL to complete 20 hr dual instrument flight time, of which 10 hr may be completed on an approved synthetic flight trainer.
Chapter 2, Paragraph 2.4.3.1.1.1 d) and 2.4.4.1.1.1 d)	Canada requires applicants for a CPL to complete 5 hr dual night flight time and 5 hr solo night flight time. Solo time includes 10 takeoffs and 10 landings.
Chapter 2, Paragraph 2.6.1.3.1	Canada does not require applicants for an ATPL-A to complete the "Skill" requirement using an aeroplane required to be operated with a co-pilot.
Chapter 2, Paragraph 2.6.3.1.1.1 a) and 2.6.4.1.1.1 a)	Canada credits 50% of pilot-in-command under supervision flight time, up to 100 hr, towards the ATPL-A, and up to 150 hr towards the ATPL-H.
Chapter 2, Paragraph 2.7.1.3.1	Canada does not require a PPL holder with an instrument rating to hold a Category 1 (Class 1) Medical Assessment for hearing acuity.
Chapter 2, Paragraph 2.7.1.3.2 (Recommended practice)	Canada does not require a holder of an instrument rating to hold a Category 1 (Class 1) Medical Assessment.
Chapter 2, Paragraph 2.10.1.1	Canada requires applicants for a Balloon Pilot Licence to be a minimum of 17 years of age.

1.9. MEDICAL FITNESS FOR PERMITS AND LICENCES

The medical standards for Civil Aviation Flight Crew Licences have been established in accordance with the International Standards and Recommended Practices of the ICAO and are outlined in the CARs, subpart 424. The medical assessment is required to allow permit or licence holders to exercise their licensing privileges.

NOTE: A Category 4 Medical Certificate is issued for certain permits and licences for use in Canadian airspace only.

Medical fitness for a Category 1, 2 or 3 Medical Certificate is established by a medical examination conducted by a Canadian Civil Aviation Medical Examiner (CAME) or an Aviation Medical Examiner designated by the licensing authority of an ICAO contracting State.

If the medical examination is conducted by an Aviation Medical Examiner designated by the licensing authority of an ICAO contracting State, the completed medical examination report shall be forwarded to TCCA Medicine Branch for review and assessment:

Civil Aviation Medicine Branch
 Transport Canada
 330 Sparks St.
 Place de Ville, Tower "C", Room 617
 Ottawa ON K1A 0N8

Medical fitness for a Category 4 Medical Certificate is established by completing a medical declaration on the *Medical Declaration for Licences and Permits Requiring a Category 4 Medical Standard* form—TP 26-0297, which can be obtained at www.tc.gc.ca/wwwdocs/Forms/26-0297_0712-06_BO.pdf.

The age of the applicant and the type of permit or licence being applied for determine the frequency of medical examinations to meet the medical fitness requirements.

The validity period of a medical certificate is calculated from the first day of the month following the date of the medical examination or medical declaration.

1.9.1 Medical Validity Periods

The following table provides the medical validity periods for the following permits, licences and ratings:

PERMIT, LICENCE or RATING HELD	FLIGHT CREW UNDER 40 YEARS OF AGE	FLIGHT CREW 40 YEARS OF AGE or OLDER
Student Pilot Permit	60 months	60 months
Gyroplane Pilot Permit	60 months	24 months
Ultra-light Pilot Permit-Aeroplane	60 months	60 months
Passenger carrying Ultra-light-Aeroplane	60 months	24 months
Recreational Pilot Permit-Aeroplane	60 months	24 months
Glider Pilot Licence	60 months	60 months
Balloon Pilot Licence	60 months	24 months
Private Pilot Licence-Aeroplane and Helicopter	60 months	24 months
Multi Crew Pilot Licence-Aeroplane	TBA	TBA
Commercial Pilot Licence-Aeroplane and Helicopter	12 months	6 months
Airline Transport Pilot Licence - Aeroplane and Helicopter	12 months	6 months
Flight Engineer Licence	12 months	12 months
Flight Instructor Rating-Glider	60 months	60 months
Flight Instructor Rating-Ultra-light-Aeroplane	60 months	60 months

1.9.2 Medical Fitness: Renewals for Category 1, 2 or 3 Medical Certificates (Assessed Fit)

Medical fitness Renewals for a Category 1, 2 or 3 Medical Certificate may be conducted by a Canadian Civil Aviation Medical Examiner (CAME) or an Aviation Medical Examiner designated by the licensing authority of an ICAO contracting State.

If the holder is assessed medically “fit” for that permit or licence by a CAME, the examiner will renew the medical certificate for the full validity period by placing a stamp with a date and signature in the appropriate position on the applicable page in the Medical Section of the *Aviation Document Booklet*.

If the medical examination is conducted by an Aviation Medical Examiner designated by the licensing authority of an ICAO contracting state, the completed medical examination report shall be forwarded to TCCA Medicine Branch for review and assessment:

Civil Aviation Medicine Branch
 Transport Canada
 330 Sparks St.
 Place de Ville, Tower “C”, Room 617
 Ottawa ON K1A 0N8

If the holder is assessed medically “fit” for that permit or licence by TCCA Medicine Branch, a new medical certificate will be issued.

1.9.3 Medical Fitness: Renewals for Category 4 Medical Certificate

A pilot wishing to maintain a Category 4 Medical Certificate shall complete the *Medical Declaration for Licences and Permits Requiring a Category 4 Medical Standard* form 60 days before the expiry date of the medical certificate. This will allow Transport Canada licensing personnel enough time to issue a new Category 4 Medical Certificate before the original medical certificate expires.

1.9.4 Medical Fitness: Assessed Unfit

A small percentage of applicants for a medical certificate may be assessed as “unfit” and these applicants will not be issued a medical certificate.

The underlying goal of the medical assessment is to allow permit or licence holders to exercise their licensing privileges. In an “unfit” assessment where the applicant is on the borderline of a medical standard, the applicant’s medical information will be reviewed by the Aviation Medical Review Board.

In this situation, “flexibility” may be applied to the medical standard to allow the applicant to exercise the privileges of their permit or licence, provided aviation safety is not compromised.

The Aviation Medical Review Board is comprised of a group of specialists in neurology, cardiology, psychiatry, ophthalmology, internal medicine and otolaryngology established within the Civil Aviation Medicine Branch. internal medicine and otolaryngology established within the Civil Aviation Medicine Branch.

1.10 REFUSAL TO ISSUE A PERMIT, LICENCE, RATING OR MEDICAL CERTIFICATE

The Minister’s power to refuse to issue or amend a permit, licence, rating or medical certificate is set out in the amended AA.

The four grounds for refusing to issue are as follows:

- (a) incompetence of the applicant for the document or amendment;
- (b) failure to meet the qualifications or fulfill the conditions necessary for the issuance or amendment of the document;
- (c) public interest reasons; and
- (d) failure by the applicant to pay monetary penalties for which the Tribunal has issued a certificate.

Where the Minister decides to refuse to issue or amend a Permit, Licence, Rating or Medical Certificate, the Minister will forward a “*Notice of Refusal To Issue or Amend a Canadian Aviation Document*” letter to the applicant. The letter states the grounds and the specific reasons for the decision.

The applicant has the right to request a review of the Minister’s decision with the Transportation Appeal Tribunal of Canada (TATC).

1.11 REINSTATEMENT OF A SUSPENDED PERMIT, LICENCE OR RATING

To reinstate a flight crew permit, licence or rating that has been suspended under the AA subsection 7.1(1), the applicant shall provide proof that they have satisfied the conditions of the suspension.

1.12 RECENCY REQUIREMENTS

Flight crew must meet the CAR requirements for recency in order to exercise the privileges of their permit, licence or rating in accordance with section 401.05 and 421.05 of the CARs.

(1) For 5-year recency, the pilot must have either:

- flown as pilot-in-command or co-pilot within the previous 5 years; or
- completed a flight review with an instructor and written and passed the PSTAR exam within the previous 12 months.

(2) For the 24-month recurrent training program, the pilot must complete one of the seven recurrent training programs:

- a flight review with an instructor;
- a safety seminar conducted by TCCA;
- a TCCA-approved recurrent training program;
- a Self Paced Recency Questionnaire;
- a training program or PPC required by Part IV, VI or VII of the CARs;
- the requirements for the issue or renewal of a licence permit or rating; or
- the written exam for a licence, permit or rating.

(3) For other recency requirements for other flight crew, other categories of aircraft, instrument ratings and passenger carrying, refer to sections 401.05 and 421.05 of the CARs.

1.13 FLIGHT CREW LICENSING CONVERSION AGREEMENT BETWEEN CANADA AND THE UNITED STATES

The USA and Canada signed an international agreement known as the *Bilateral Aviation Safety Agreement (BASA)*. Within this agreement, the Federal Aviation Administration (FAA) and TCCA have established procedures for issuing aeroplane pilot licences or certificates and ratings on the basis of a certificate or licence issued by the other authority.

General Conditions for the Conversion Agreement

NOTE: Licences or certificates in the aeroplane category that are endorsed “Issued on the basis of a foreign licence” are NOT eligible for this conversion process.

The licence conversion process is currently limited to the airplane category at the private, commercial, and airline transport pilot levels. It includes the following ratings or qualifications addressed under 14 CFR Part 61 and CARs, Part IV:

- (a) instrument rating;
- (b) class ratings of airplane single engine land;
- (c) airplane multi-engine land;
- (d) type ratings; and
- (e) night qualifications.

Applicants shall:

- be able to communicate in English (in Canada—English or French);
- hold the appropriate medical certificate;
- meet the age requirement specified in the agreement;
- pass the applicable written examination;
- meet the licence conversion requirements specified in the agreement; and
- pay the applicable fee.

No flight test is required for applicants through this conversion process.

Applicants converting a Canadian pilot licence to a FAA pilot certificate should contact the FAA for further information. See contact details at www.faa.gov/licenses_certificates/airmen_certification/contact_airmen_certification/.

Applicants converting an FAA pilot certificate to a Canadian pilot licence should refer to www.tc.gc.ca/eng/civilaviation/standards/general-personnel-usconversion-480.htm.

1.14 FLIGHT CREW LICENSING ADMINISTRATION

- (1) Flight Crew Licensing Change of Address Request: TCCA shall be advised of any change of mailing address within 7 days following the change in accordance with section 400.07 of the CARs. Submit a completed TP 6-0760 form to your TCCA regional licensing office. The form can be obtained at www.tc.gc.ca/wwwdocs/Forms/26-0760_1004-02_BO.pdf.
- (2) Application for Re-Issue of Civil Aviation Licensing Document: For a permit or licence that is not received in the mail, or is lost, stolen, destroyed or rendered illegible, submit a completed TP 26-0738 form to your TCCA regional licensing office. The form can be obtained at www.tc.gc.ca/wwwdocs/Forms/26-0738_0912-02_BO.pdf.
- (3) Flight Crew Licensing Declaration of Name: TCCA shall be advised of any change in your given name or surname. Submit a completed TP 26-0759 form to your TCCA regional licensing office. The form can be obtained at www.tc.gc.ca/wwwdocs/Forms/26-0759_1001-01_BO.pdf.
- (4) Change of Citizenship: TCCA shall be advised of any change in your citizenship. Submit a letter to your TCCA regional licensing office notifying them of the change. The letter must be accompanied by proof of new citizenship in accordance with section 421.06 of the CARs Standard.

2.0 Civil Aviation Medicine (CAM)

2.1 MEDICAL ASSESSMENT PROCESS

2.1.1 Medical Examination Report

All holders of Canadian pilot licences or permits or air traffic controller licences must undergo a periodic medical examination to determine their medical fitness in order to exercise the privileges of their permit or licence. This medical examination will normally be carried out by a designated Civil Aviation Medical Examiner (CAME). The frequency of medical examinations depends on the age of the applicant and the type of permit or licence applied for. For some examinations, supplementary tests, such as an audiogram or an electrocardiogram (ECG), may be required. The schedule for periodic examinations can be found in CAR 404.04 (6) or on the Transport Canada Civil Aviation Web site: www.tc.gc.ca/eng/civilaviation/regserv/cars/part4-404-1075.htm#404_04.

There are approximately 700 physicians who are designated by Transport Canada as CAMES. They are strategically located across the country and overseas.

If the examination is performed in a contracting ICAO State, the examination must be completed by a medical examiner designated by Canada or by that State. The resulting medical examination must meet the Canadian physical and mental requirements.

Only designated Canadian CAMEs may validate a renewal examination with the official CAME stamp and by signing the medical certification section in the Aviation Document Booklet.

Local flying organizations usually have a list of examiners in their immediate area. Examiner lists are also available from the regional office of Civil Aviation Medicine (CAM) or on the TCCA Web site: <www.wapps.tc.gc.ca/saf-sec-sur/2/came-meac/l.aspx?lang=eng>.

2.1.2 Category 4 Medical Declaration

When applying for the issue or revalidation of any of the Canadian aviation documents (CAD) listed below, the applicant may apply to obtain a category 4 medical certificate by completing the Medical Declaration for Licences and Permits Requiring a Category 4 Medical Standard form (Form # 26-0297):

- (a) Student Pilot Permit–Aeroplane;
- (b) Pilot Permit–Recreational;
- (c) Pilot Permit–Ultra-light Aeroplane;
- (d) Student Pilot Permit–Glider; and
- (e) Pilot Licence–Glider.

This medical declaration may be used to determine the applicant's medical fitness to exercise the privileges of their permit. When completing the above-mentioned medical declaration, the applicant will not normally be required to undergo a periodic medical examination by a CAME.

The Medical Declaration for Licences and Permits Requiring a Category 4 Medical Standard form (Form # 26-0297) is composed of three parts.

Part A

All applicants must complete this part of the form. Part A requires the applicant to fill in their name, current address and other personal information.

Part B

All ultra-light and glider pilot applicants are required to complete, sign and date Part B of the medical declaration and have it signed by a witness.

Applicants for a Student Pilot Permit–Aeroplane and a Pilot Permit–Recreational are required to complete, sign and date Part B of the medical declaration. There is no requirement to have a witness signature in this case.

NOTE: If the applicant has ever suffered from any of the conditions listed in Part B, they must undergo a medical examination with a CAME.

Part C (*applies only to Student Pilot Permit–Aeroplane or Pilot Permit–Recreational*)

In addition to completing Part B, Student Pilot Permit–Aeroplane or Pilot Permit–Recreational holders need to have Part C of the medical declaration completed by a physician licensed in Canada or a CAME. There is no requirement to have a witness signature in this case.

All Pilot Permit–Recreational applicants will require a resting 12-lead electrocardiogram (ECG) after the age of 40, as well as on the first medical examination after the age of 50, and then every 4 years thereafter. The ECG tracing is not required to be submitted with the medical declaration form.

When a category 4 medical declaration is completed in full, the candidate must submit the above-mentioned form to a Transport Canada regional office, where a medical certificate will be issued.

An applicant may have completed the category 4 medical declaration, but may not act as a flight crew member unless the candidate can produce the appropriate medical certificate. Please refer to CAR 401.03 for more details.

A pilot renewing a category 4 medical declaration should complete the declaration form 60 days before the expiry date of the medical certificate. This will allow Transport Canada licensing personnel enough time to issue a new category 4 paper medical certificate or label for the Aviation Document Booklet before the original medical certificate expires.

An applicant holding a category 4 medical certificate may exercise the privileges of the appropriate permit or licence while flying in Canadian airspace only.

NOTE: If an applicant wishes to obtain a private pilot licence or higher or intends to pursue a career in aviation, it is advisable to forego a category 4 application and apply directly for a category 3 or 1 medical certificate in order to save time and money.

2.2 MEDICAL EXAMINATION REQUIREMENTS

MEDICAL CATEGORY	AUDIOGRAM	ELECTROCARDIOGRAM	
1 and 2	At the initial examination and at the first medical examination after age 55 (unless done during the preceding 60 months)	Age under 30	At the initial examination
		Age 30–40	Within 24 months preceding the examination
		Age over 40	Within 12 months preceding the examination
3	Not required unless clinically indicated	Age under 40	Not required unless clinically indicated
		Age 40 and over	At the first examination after age 40 and then within the 48 months preceding the examination
4 ¹ For Recreational Pilot Permit	Not required unless clinically indicated	Age under 40	Not required unless clinically indicated
		Age 40–50	At the first application (declaration or examination) after age 40
		Age over 50	At the first application after age 50 and then within the 48 months preceding the application

¹An electrocardiogram (ECG) is not required when a category 4 medical certificate is only to be used for flying gliders or ultra-light aircraft, unless clinically indicated.

These requirements can be found in the CAR 424.17(4) table “Responsibilities of Medical Examiner-Physical and Mental Requirements for Medical Categories” at the following Web site: <www.tc.gc.ca/eng/civilaviation/regserv/cars/part4-standards-t42402-1412.htm>.

2.3 PERIODIC MEDICAL EXAM CATEGORIES 1, 2, 3 – MEDICALLY FIT

When the examination has been completed, the examiner will make a recommendation of fitness and will forward the Medical Examination Report (MER) to the Regional Aviation Medical Officer (RAMO) at the appropriate regional office for review. If the person is already the holder of a Canadian pilot permit or licence or air traffic control licence and is, in the opinion of the examiner, medically fit, the examiner will extend the medical validity of the holder’s permit or licence for the full validity period by signing and stamping the *Aviation Document Booklet* in the medical certification section.

The *Aviation Document Booklet* has a five-year validity period.

2.4 AVIATION MEDICAL REVIEW BOARD

A small percentage of applicants will have medical issues that place them outside the medical standard. In those cases, their medical information may be reviewed by the Aviation Medical Review Board. The Review Board, a group of specialists in neurology, cardiology, psychiatry, ophthalmology, internal medicine, otolaryngology and aviation medicine, meets regularly in Ottawa to review complex cases and makes recommendations to the RAMO.

2.5 UNFIT ASSESSMENT

Less than 1% of all applicants are assessed as unfit, a decision that is not made lightly. The underlying goal of the medical assessment is to allow permit/licence holders to maintain their privileges whenever possible within the bounds of aviation safety. Flexibility may be applied to the medical standard if there is a counterbalancing safety restriction and/or a change in periodicity of medical surveillance that could be applied to a holder’s permit or licence, which will compensate for the deviation from the standard. An example of this is a pilot with certain medical conditions being restricted to flying “with or as an accompanying pilot”.

If an applicant is assessed as unfit, he or she will be informed by the RAMO in writing, and also by the Regional Manager, Civil Aviation Services at TCCA. If it is the applicant's initial application, a medical certificate will not be issued. If the applicant holds a medical certificate, it will either be suspended or cancelled. If a medical certificate was previously held, a letter refusing to renew the document will be issued to the applicant.

If a medical certificate is refused, suspended, cancelled or not renewed, the initial applicant or permit/licence holder may wish to discuss and review their medical assessment with the RAMO. At the teleconference and/or meeting, the RAMO will review, with the applicant or permit/licence holder, the medical information relevant to the assessment. As a general rule, the applicant or permit/licence holder may see these documents in the presence of the RAMO and ask questions concerning the content of the documents relative to the medical standards. In the case of sensitive or complicated medical information, the RAMO may elect to refer questions of a more clinical nature to the applicant or permit/licence holder's personal physician, who can better explain the implications. In such cases, the applicant or permit/licence holder will be asked to provide a "consent to release" document designating a physician to receive these reports.

2.6 REVIEW BY THE TRANSPORTATION APPEAL TRIBUNAL OF CANADA (TATC)

Should the initial applicant or permit/licence holder wish a review of the medical certification decision by the TATC, he or she must file a request for review by the date specified in the notice that suspends, cancels, refuses to issue, or refuses to renew his or her medical certificate. The TATC will acknowledge the request and subsequently set a hearing date. Any questions on hearing procedures should be directed to the TATC, which is independent from TC.

If the applicant or permit/licence holder has new or additional medical information, it is suggested that it be shared with the RAMO before the hearing, as it may be sufficient to permit the RAMO to recommend reinstatement of the medical certificate. If that is the case, the applicant or permit/licence holder will be spared the inconvenience of a hearing before the TATC. Whether the applicant or permit/licence holder elects to disclose this evidence or not, the right to a hearing before the TATC is not affected, but the Tribunal will decline to make a determination of the case if the new evidence hasn't been reviewed by CAM.

If the applicant or permit/licence holder does decide to proceed with a review by the TATC, the following are the procedural steps.

The review will normally be heard by a single member of the TATC. If this member decides in the applicant or permit/licence holder's favour, the determination will be that "the Minister reconsider his decision." The TATC does not have the power to require the Minister to issue a valid medical certificate to the applicant or permit/licence holder.

If the TATC member does not decide in the applicant's or permit/licence holder's favour, this decision may be appealed to a three-member board of the TATC. If the three-member board of the TATC decides in the applicant's or permit/licence holder's favour, the determination will be that "the Minister reconsider his decision." If the three-member board does not decide in the applicant's or permit/licence holder's favour, there is no further avenue of appeal to the TATC.

If either the single-member TATC or the three-member TATC decides that "the Minister reconsider his decision," TC does not have the right of appeal and the merits of the case will be reconsidered.

As part of the reconsideration process, the Director, Standards will ask the Director, Civil Aviation Medicine to review the case and provide him or her with a recommendation regarding the applicant's or permit/licence holder's medical fitness. The Director, Civil Aviation Medicine does not normally participate in the medical review by the RAMO or in the Aviation Medical Review Board recommendations, and is thus able to formulate an unbiased opinion after an independent review of all of the medical evidence available. If the Director of Medicine has been involved, the case will be referred outside the department for a second opinion.

After that time, a final decision will be made by the Director, Standards regarding the medical assessment, and the applicant or permit/licence holder will be notified of the decision by mail.

3.0 FLIGHT CREW EXAMINATIONS

3.1 USE OF HAND-HELD CALCULATORS OR COMPUTERS FOR WRITTEN EXAMINATIONS

- (a) An applicant may use a pocket electronic calculator for problem solving, including those with a tape printout, if it has no memory system.
- (b) An applicant may use a pocket electronic computer that has been specifically designed for flight operations, including a self-prompting type, provided it has been approved by Transport Canada for examination purposes and the computer memory bank is cleared before and after the examination, in the presence of the examination invigilator.
- (c) Requests for pocket electronic computer approval are to be forwarded by the manufacturer, along with a functional sample computer, all available software, if applicable, and instructions on completely clearing all memory without affecting any programming to:

Transport Canada
Flight Crew Examinations (AARTG)
330 Sparks Street
Ottawa ON K1A 0N8

The memory bank clearing instructions and the process shall be simple enough to be completed with minimum distraction to invigilators.

NOTES 1: No computer capable of being used to type and store a significant quantity of language text will be approved.

2: No device capable of accessing other applications or networks will be approved.

- (d) The Jeppesen/Sanderson PROSTAR and AVSTAR, the Jeppesen TECHSTAR and TECHSTAR PRO, the ASA CX-1a Pathfinder and ASA CX-2 Pathfinder, the Cessna Sky/Comp, the NAV-GEM, and the Sporty's E6B electronic flight computers have been approved for use with all flight crew personnel licensing written examinations requiring numerical computations.
- (e) An applicant may not use an instructional handbook or a user's manual when writing a Transport Canada examination.
- (f) Upon completion of a written examination, all printout material shall be given to the invigilator.

4.0 AIRCRAFT IDENTIFICATION, MARKING, REGISTRATION AND INSURANCE

4.1 GENERAL

No civil aircraft, other than hang gliders or model aircraft, shall be flown in Canada unless it is registered in accordance with the *Canadian Aviation Regulations* (CARs), Part II, or under the laws of an International Civil Aviation Organization (ICAO) Member State, or a State that has a bilateral agreement with Canada concerning interstate flying

To be eligible for registration in Canada, an aircraft must be of a type that has been approved in Canada for issuance of a Certificate of Airworthiness, Special Certificate of Airworthiness or Flight Permit (except ultra-light aeroplanes), and the "owner" must be qualified in accordance with the CARs, Part II, to be the registered owner of a Canadian aircraft.

4.2 AIRCRAFT IDENTIFICATION

Under CAR 201.01, Canadian-registered aircraft are required to have an aircraft identification plate attached to the aircraft. The fireproof identification plate bears information relating to the manufacturer of the aircraft, model designation, type certificate number and serial number. A photograph of the identification plate, clearly reproducing the information it contains, is required at the time of application for a Certificate of Registration (C of R).

4.3 NATIONALITY AND REGISTRATION MARKS

No person shall operate a registered aircraft in Canada unless its nationality and registration marks are clean, visible and displayed in accordance with the CARs or laws of the state of registry.

Canadian nationality and registration marks for new or imported aircraft are issued, on request, by the appropriate Transport Canada (TC) regional office. Should an applicant request a specific mark that is not the next available mark, it is deemed to be a "special mark" and may be obtained, if available, upon payment of a fee. Marks may be reserved for a one-year period without being assigned to a specific aircraft, also upon payment of a fee.

Aircraft registration marks are composed of a nationality mark and a registration mark. The Canadian nationality marks are the capital letters "C" or "CF". "CF" may only be issued for vintage ("heritage") aircraft (aircraft manufactured prior to January 1, 1957). If the nationality mark is "CF", the registration mark is a combination of three capital letters. If the nationality mark consists only of the capital letter "C", the registration mark is a combination of four capital letters beginning with "F" or "G" for regular aircraft (including amateur-built aircraft).

In the case of basic and advanced ultra-light aeroplanes, the registration mark is a combination of four capital letters beginning with “I”. The nationality mark shall precede the registration mark and be separated from it by a hyphen.

Aircraft manufactured before January 1, 1957, are considered to be “heritage aircraft” and are eligible to display either the “C” or “CF” nationality mark. Aircraft manufactured after December 31, 1956, will be issued only “C” nationality marks. Those aircraft manufactured after December 31, 1956, that now display the “CF” nationality mark may continue to do so until such time as the aircraft is next painted, after which the aircraft shall display the “C” nationality mark (e.g. *CF-XXX* becomes *C-FXXX*). Upon changing the mark, the TC regional office shall be notified in writing.

The specifications for Canadian nationality and registration marks are contained in CAR 202.01 and are in accordance with the Aircraft Marking and Registration Standards of the CARs. For detail on the placement and size of aircraft marks, see CAR 222.01, Aircraft Marking and Registration Standards.

CAR 202.04(1)(c) provides for marks to be changed after an aircraft has been registered. This has to do with the removal or change of marks after granting of continuing registration. The aircraft may be removed from the register if it is destroyed or permanently withdrawn from service. The aircraft is removed from the register if it is exported. It is the responsibility of the owner to notify TC immediately if any of these events occur. The owner shall also notify TC in writing within seven days of a change in the owner’s name or permanent address.

4.4 CHANGE OF OWNERSHIP—CANADIAN-REGISTERED AIRCRAFT

When the ownership of a Canadian-registered aircraft changes, the registration is cancelled and the registered owner must notify TC in writing no more than seven days after the change. A pre-addressed postcard-type notice is provided with the C of R for this purpose. The C of R contains the forms and instructions necessary to activate and apply for registration in the name of the new owner.

4.5 INITIAL REGISTRATION

To obtain an application for registration, the new owner should contact the applicable TC regional office. The applicant can also access the forms (26-0522 or 26-0521) online at <http://tcapps/Corp-Serv-Gen/5/forms-formulaires/search.aspx>. No person shall operate an aircraft in Canada unless it is registered.

4.6 IMPORTATION OF AIRCRAFT INTO CANADA

ICAO’s *Convention on International Civil Aviation* and the CARs state that an aircraft cannot be registered in more than one State at the same time. Therefore, persons proposing to import an aircraft into Canada and have it registered should, prior to making any commitments to purchase, communicate with the nearest TCCA regional office, Transport Canada Centre (TCC) or Minister’s Delegate – Maintenance (MD-M) to ascertain the eligibility of the aircraft for import and registration.

4.7 EXPORTATION OF AIRCRAFT

When a Canadian-registered aircraft is sold or leased to a person who is not qualified to be the owner of a Canadian aircraft and the aircraft is not in Canada at the time of the sale or lease, or it is understood by the vendor or lessor that the aircraft is to be exported, the vendor shall ensure that the requirements of CAR 202.38 are satisfied. The vendor or lessor shall:

- (a) remove the Canadian marks from the aircraft and, if applicable, the aircraft address from the Mode S transponder and from the other avionics equipment of the aircraft;
- (b) notify the Minister in writing, within seven days after the sale or lease, of the date of:
 - (i) the sale or lease;
 - (ii) the exportation, if applicable;
 - (iii) the removal of the Canadian marks; and
 - (iv) the removal of the aircraft address from the Mode S transponder and from the other avionics equipment of the aircraft, if applicable;
- (c) provide the Minister with a copy of all of the agreements that relate to the transfer of any part of the legal custody and control of the aircraft resulting from the sale or lease; and
- (d) return the certificate of registration of the aircraft to the Minister.

TC will remove the aircraft from the *Canadian Civil Aircraft Register* and forward a notification of cancellation of Canadian registration to the foreign National Aviation Authority (NAA) of the country to which the aircraft is being exported upon receipt of a request from the registered owner and only after the foregoing conditions have been met.

4.8 LIABILITY INSURANCE

Canadian and foreign aircraft operated in Canada, or Canadian aircraft operated in a foreign country, are required to have public liability insurance. In the case of most air operators (those operating under CARs 703, 704 and 705), the specific requirement can be found in section 7 of the *Air Transportation Regulations*; for other air operators, the requirement is outlined in CAR 606.02. Public liability insurance protects the owner and operator of the aircraft in the event that the aircraft causes damage to persons or property.

Similarly, passenger liability insurance is required in certain circumstances, as indicated in section 7 of the *Air Transportation Regulations*. Passenger liability insurance is required by operators operating under the authority of an Air Operator Certificate, a Flight Training Unit Operator Certificate, or a Special Flight Operations Certificate for balloons with fare-paying passengers. Certain privately operated aircraft require both public and passenger liability insurance [CARs 606.02(4) and 606.02(8)]. Passenger liability insurance protects the owner and operator of the aircraft if a passenger on board the aircraft suffers from injury or death.

Essentially, passenger liability insurance is not mandatory for aerial work operators certified under CAR 702, as they do not carry passengers.

Details on the specific amounts of public liability insurance required and how to calculate passenger liability insurance are in CAR 606.02.

5.0 AIRCRAFT AIRWORTHINESS

5.1 GENERAL

This section provides an explanation of the means by which TC exercises regulatory oversight to ensure the continuing airworthiness of Canadian-registered aircraft. It focuses on the general intent of the regulatory process rather than dealing with the applicable airworthiness requirements and procedures in detail. The reader should consult the applicable *Canadian Aviation Regulations* (CARs) that are mentioned in this section if a more detailed understanding of the current airworthiness requirements and procedures is required.

It is the responsibility of the owner or pilot to ensure that Canadian-registered aircraft are fit and safe for flight prior to being flown. The primary regulatory control for meeting this objective is achieved by making it unlawful for any person to fly or attempt to fly an aircraft, other than a hang glider or an ultra-light aeroplane, unless flight authority in the form of a valid certificate of airworthiness (C of A), special certificate of airworthiness (Special C of A), or Flight Permit—whichever is applicable—has been issued for that aircraft (CARs 507.02, 507.03, and 507.04).

5.2 AIRCRAFT DESIGN REQUIREMENTS

5.2.1 General

The *Convention on International Civil Aviation*, signed in Chicago in 1944, mandated that every aircraft of a contracting State engaged in international aerial navigation be provided with a C of A issued or rendered valid by the State in which it is registered. This agreement has the following effects:

- (a) to promote the idea of mutually acceptable aircraft design standards between contracting States;
- (b) to provide all contracting States with the assurance that the aircraft of any other contracting State flying over their territories were certificated to a common minimum acceptable level of airworthiness; and
- (c) to achieve minimum acceptable standards in matters related to the continuing airworthiness of the aircraft.

The ultimate objective of this agreement is to protect other aircraft, third parties, and people on the ground from any hazards associated with overflying aircraft.

5.2.2 Canadian Type Certificate (CARs, Part V, Subpart 21)

CAR 521 establishes the rules that govern the application for and the issuance of a design approval document. The Regulation also enables the use of the *Airworthiness Manual* chapters that establish the design standards for various categories of aircraft. The standards may be defined as statements of the minimum acceptable properties and characteristics of the configuration, material, performance and physical properties of an aircraft.

Applicants are issued a design approval document once they have demonstrated that the type design of the aeronautical product conforms with the applicable airworthiness and noise and engine emission standards that are in force for the product. The design approval document certifies that the type design of the product meets the applicable standards and prescribes the conditions and limitations by which that product met the standards.

NOTE: A design approval document is defined in CAR 521.01 as “a type certificate, a supplemental type certificate, a repair design approval, a part design approval or a Canadian Technical Standard Order (CAN-TSO) design approval.”

5.3 FLIGHT AUTHORITY AND NOISE COMPLIANCE

5.3.1 General

Section 605.03 of the CARs prescribes that:

- (1) “No person shall operate an aircraft in flight unless:
 - (a) a flight authority is in effect in respect of the aircraft;
 - (b) the aircraft is operated in accordance with the conditions set out in the flight authority; and
 - (c) subject to subsections (2) and (3), the flight authority is carried on board the aircraft.
- (2) Where a specific-purpose flight permit has been issued pursuant to Section 507.04, an aircraft may be operated without the flight authority carried on board where:
 - (a) the flight is conducted in Canadian airspace; and
 - (b) an entry is made into the journey log indicating:
 - (i) that the aircraft is operating under a specific-purpose flight permit, and
 - (ii) where applicable, any operational conditions that pertain to flight operations under the specific-purpose flight permit.
- (3) A balloon may be operated without the flight authority carried on board where the flight authority is immediately available to the pilot-in-command:
 - (a) prior to commencing a flight; and
 - (b) upon completion of that flight.”

A flight authority may be issued in the form of a C of A, a Special C of A or a flight permit. The specific requirements and procedures for each are detailed in CAR 507 and its related Standard.

5.3.2 Certificates of Airworthiness

The C of A is issued for aircraft that fully comply with all standards of airworthiness for:

- (a) aeroplanes in the normal, utility, aerobatics, commuter and transport categories;
- (b) rotorcraft in the normal and transport categories; and
- (c) gliders, powered gliders, airships, and manned free balloons.

The C of A is transferable with the aircraft when sold or leased, provided the aircraft remains registered in Canada. The C of A may provide an indication of the aircraft’s compliance status with respect to the noise limitations specified in Chapter 516 of the *Airworthiness Manual*. When applying for a C of A, it is advisable for the owner to have, or obtain a copy of, the applicable type certificate data sheets. A copy of the data sheets can be obtained from the type certificate holder. The data sheets may also be found online at <<http://www.wapps.tc.gc.ca/saf-sec-sur/2/nico-celn/>>.

Nothing in the CARs or their associated Standards relieves the operator of a Canadian aircraft from the requirement to comply with local regulations when operating outside Canada. An aircraft for which the Minister has issued a C of A is considered to be fully in compliance with Article 31 of ICAO’s *Convention on International Civil Aviation*, thereby meeting the code established by ICAO in Annex 8—*Airworthiness of Aircraft*. Regarding airworthiness, aircraft meeting this code can be flown without further approval in the airspace of any ICAO contracting State.

5.3.3 Special Certificates of Airworthiness

A Special C of A may be issued for an aircraft in one of the following classifications: restricted, amateur-built, limited or owner-maintenance. The requirements and procedures for each classification are specified in CAR 507 and its related Standard.

An aircraft for which a Special C of A is issued by the Minister is not considered to be in compliance with all requirements of the code in ICAO’s Annex 8 and cannot be flown in the airspace of another country without special authorization by the civil aviation authority of that other country.

Appendix H of CAR Standard 507 lists aircraft types and models that are eligible for a Special C of A—owner-maintenance. This Special C of A permits the owners to perform and certify maintenance on their aircraft, provided the relevant requirements of the CARs and the associated Standards are met.

Aircraft owners who apply for a C of A for an aircraft for which the last permanent flight authority issued was a Special C of A—owner-maintenance must meet the additional relevant requirements set out in CAR Standard 507.02(3).

5.3.4 Flight Permit

CARs Standard 507.04 prescribes that:

- (1) “A flight permit shall only be issued on a temporary (12 months or less) basis where the aircraft in respect of which an application is made does not conform to the conditions of issue for a C of A or a Special C of A. A flight permit is issued in an experimental or specific purpose classification.
- (2) Flight Permit—Experimental

An experimental flight permit is issued for any aircraft, excluding aircraft that are operated under a Special C of A in the owner-maintenance or amateur-built classification, which is manufactured for, or engaged in, aeronautical research and development, or for showing compliance with airworthiness standards.

(3) Flight Permit—Specific Purpose

A specific purpose flight permit is issued for an aircraft which does not conform to applicable airworthiness standards, but is capable of safe flight. It provides flight authority in circumstances when a C of A is invalidated, or there is no other certificate or permit in force.

Information note: Specific purpose flight permits may be issued for:

- (a) ferry-flights to a base for repairs or maintenance;
- (b) importation or exportation flights;
- (c) demonstration, market survey or crew training flights;
- (d) test purposes following repair, modification or maintenance; or
- (e) other temporary purposes.”

5.3.5 Noise Compliance

Sections 507.20 to 507.23 of the CARs set out the requirements with respect to the application for, as well as the issuance and suspension of, certificates of noise compliance and validation of foreign certificates of noise compliance:

“In the case of a Canadian aircraft, the C of A shall be annotated to indicate that:

- (i) the aircraft complies with the applicable noise emission standards and what those standards are; or
- (ii) the noise compliance requirements are not applicable to the aircraft.”

5.4 MAINTENANCE CERTIFICATION

5.4.1 General

CAR 605.85 stipulates, in part, that “no person shall conduct a take-off in an aircraft, or permit a take-off to be conducted in an aircraft that is in the legal custody and control of the person, where that aircraft has undergone maintenance, unless the maintenance has been certified by the signing of a maintenance release pursuant to section 571.10.” Details of the maintenance activities performed must also be entered in the technical log.

Specific qualifications for personnel who can sign a maintenance release are indicated in CAR 571 and its related Standard. The owner of an amateur-built or owner-maintenance aircraft can perform the work and sign the maintenance release for his or her own aircraft.

It is the owner’s responsibility to ensure that only personnel meeting those qualifications sign a maintenance release for his or her aircraft, engine, propeller or other installed component. The standards and procedures applicable to a maintenance release are contained in Standard 571—*Maintenance*.

Elementary work does not require a maintenance release to be signed by an AME. However, pursuant to Section 571.03 of the CARs, any elementary work performed on an aircraft must be detailed in the technical record and accompanied by the signature of the person who performed the work. Appendix A of Standard 625—*Aircraft Equipment and Maintenance Standard* lists the tasks and conditions associated with elementary work.

5.4.2 Certification of Maintenance Performed Outside Canada

In the case of maintenance performed outside Canada (except for the annual inspection portion of the maintenance schedule outlined in Part I or II of Appendix B of Standard 625—*Aircraft Equipment and Maintenance Standard*), a maintenance release may be signed by a person who is authorized to sign under the laws of a State that is a party to an agreement or a technical arrangement with Canada and the agreement or arrangement provides for such certification.

In the case of certification of the 100-hr inspection performed annually on the basis of the maintenance schedule outlined in Appendix B of Standard 625—*Aircraft Equipment and Maintenance Standard*, a maintenance release can only be signed by the holder of an appropriately rated AME licence issued pursuant to CAR 403.

5.5 ANNUAL AIRWORTHINESS INFORMATION REPORT

CAR 501.01 requires that the owner of a Canadian aircraft, other than an ultra-light aeroplane, submit an Annual Airworthiness Information Report (AAIR) (form number 24-0059) in the form and manner specified in Chapter 501 of the *Airworthiness Manual*.

A personalized AAIR is sent to each registered aircraft owner approximately five to six weeks before the due date, which is normally the anniversary of the last issued flight authority. The aircraft owner shall complete the annual report by entering all data required and signing the certification that the information supplied is correct.

Failure to receive a personalized AAIR does not relieve the owner from the requirement to submit the report. The owner should therefore notify the appropriate TC regional office or Transport Canada Centre (TCC) if the form has not been received two weeks before the anticipated due date.

An alternative due date instead of the flight authority anniversary may be granted in accordance with CAR 501.03.

The owner of an aircraft that will be out of service for one or more reporting periods (calendar years) is not required to submit an AAIR for those periods, provided the appropriate section of form number 24-0059 is completed and indicates the date the aircraft is expected to return to service.

Copy 3 (pink) of the AAIR shall be retained by the owner. Copies 1, 2 and 4 shall be submitted to the appropriate TC regional office in accordance with the mailing instructions on the back of the form.

5.6 MAINTENANCE REQUIREMENTS FOR CANADIAN-REGISTERED AIRCRAFT

5.6.1 General

Under CAR 605—*Aircraft Requirements*, it is the responsibility of the owner or operator (defined in CAR 101—*Interpretation* as the person who has legal custody and control of the aircraft) of aircraft other than ultra-light aeroplanes or hang gliders to ensure that his or her aircraft is properly equipped for its intended uses and maintained in accordance with an approved maintenance schedule; that the defects are recorded and properly rectified or deferred; and that any applicable Airworthiness Directives (AD) have been addressed.

It is also the responsibility of owners or operators to ensure that the person intending to take off in the aircraft has the information required to establish whether or not the aircraft is airworthy for the intended flight.

It is then the responsibility of the pilot to be familiar with the available information and to make an informed decision regarding the aircraft and the intended flight.

Under CAR 605, Schedule I, pilots must also enter the particulars of any abnormal occurrence to which the aircraft has been subjected into the aircraft's records, as well as the particulars of any defect in any part of the aircraft or its equipment that becomes apparent during flight operations.

In addition to the general rules in CAR 605, private operators must also respect the maintenance requirements in CAR 604—*Private Operator Passenger Transportation* and its related Standard; commercial air operators must respect those in CAR 706—*Aircraft Maintenance Requirements for Air Operators*, and Flight Training Units must respect those in CAR 406—*Flight Training Units*.

5.6.2 Maintenance Schedules

CAR 605.86 prescribes, in part, that all Canadian aircraft except ultra-light aeroplanes or hang gliders shall be maintained in accordance with a maintenance schedule that has been approved by the Minister and that conforms to Standard 625—*Aircraft Equipment and Maintenance Standard*.

Standard 625 includes Appendices B, C and D, which are applicable to the development of maintenance schedules.

Owners of non-commercially operated small aircraft and balloons may choose to comply with Part I or II of Appendix B, as applicable, and Appendix C of Standard 625—*Aircraft Equipment and Maintenance Standard*. They need not submit any documents to the Minister for formal approval. The maintenance schedule is considered to be approved for their use by the Minister. Owners need only make an entry in the aircraft technical records that the aircraft is maintained pursuant to the maintenance schedule. Owners should periodically review the maintenance schedule to ensure that it meets the requirements.

Operators of large aircraft, turbine-powered pressurized aeroplanes, airships, any aeroplane or helicopter operated by a flight training unit, or any commercially operated aircraft must submit an application for approval of their maintenance schedule to the Minister through the TC regional office with jurisdiction over the area in which the applicant is located. The maintenance schedule shall address the requirements of Appendix D of Standard 625.

5.6.3 Maintenance Performance

CAR 571—*Aircraft Maintenance Requirements* is applicable to the performance of maintenance or elementary work. It addresses how work should be done, as opposed to what work should be done.

5.6.4 Aircraft Technical Records

CAR 605 and its related Standard prescribe and set out the requirements and procedures for keeping aircraft technical records. Pursuant to CAR 605.92(1), every owner of an aircraft shall keep the following technical records regarding the aircraft:

- “(a) a journey log;
- (b) a separate technical record for the airframe, each installed engine and each variable-pitch propeller; and
- (c) an empty weight and balance report that meets the applicable standards set out in Standard 571—*Maintenance*.”

The technical records may consist of separate technical records for each component installed in the airframe, engine or propeller. In the case of a balloon or a glider, or an aircraft operated under a Special C of A in the owner-maintenance or amateur-built classification, all technical record entries, referred to above, may be kept in the journey log.

5.6.5 Service Difficulty Reporting (SDR) Program

By means of the SDR Program, reported service difficulties are collected, analyzed and used to identify and rectify, as required, deficiencies of a design, manufacturing, maintenance or operational nature, which might affect the airworthiness of the aircraft.

TC utilizes a user-reporting system to collect service difficulty data.

The SDR Program provides a means for AMEs and private aircraft owners or operators to report service difficulties on a voluntary basis. Commercial or corporate air operators, Canadian holders of design approval documents, and approved organizations engaged in the manufacture, maintenance, repair or overhaul of aeronautical products are subject to the mandatory SDR reporting prescribed by the CARs and as set out in Division IX of CAR 521.

Service difficulties encountered in the field that have caused or may cause a safety hazard may be reported to the Minister using either a Service Difficulty Report (form number 24-0038) or the Internet-based TC Web Service Difficulty Reporting System (WSDRS) application at <http://www.wapps3.tc.gc.ca/Saf-Sec-Sur/2/CAWIS-SWIMN/logon-wsdrs-cs16101.asp?lang=E&rand=>>.

Access to the data collected by the SDR Program is available to interested parties from the Headquarters and regional offices of TC and from the TC WSDRS application.

5.7 AIRWORTHINESS DIRECTIVES

5.7.1 General

Compliance with ADs is essential to airworthiness. Pursuant to CAR 605.84, aircraft owners are responsible for ensuring that their aircraft are not flown with any ADs outstanding against that aircraft, its engines, propellers or other items of equipment. Refer to CAR Standard 625, Appendix H, for further details.

When compliance with an AD is not met, the flight authority is not in effect and the aircraft is not considered to be airworthy.

Exemptions to compliance with the requirements of an AD or the authorization of an alternative means of compliance (AMOC) may be requested by an owner as provided for by CAR 605.84(4). Applications should be made to the nearest TC regional office or TCC in accordance with the procedure detailed in CAR Standard 625, Appendix H, subsection 4. General information about exemptions and AMOC is given in subsection 3 of that appendix.

5.7.2 Availability of ADs

TC endeavours to notify individuals of the issuance of any applicable AD or mandatory service bulletin as outlined below. For this to be accomplished, the owner must advise the nearest TCCA office of any change of address in accordance with CAR 202.51. However, TC cannot guarantee that it will receive all foreign ADs. Aircraft owners are responsible for obtaining the relevant continuing airworthiness information applicable to the type and model of aircraft, including its equipment, that they own.

Aircraft owners who wish to ascertain which ADs and service bulletins, if any, apply in Canada for a particular type of aircraft, engine, propeller or other item of equipment may do so by checking this Web site: <http://www.wapps3.tc.gc.ca/Saf-Sec-Sur/2/cawis-swimn/>.

5.7.3 AD Schedule and Compliance Records

Applicable ADs are to be scheduled and their compliance shall be certified by an authorized person in the Aircraft Journey Log and recorded in the appropriate section of the Aircraft Technical Log in accordance with the requirements of CAR 605.

6.0 THE TRANSPORTATION APPEAL TRIBUNAL OF CANADA (TATC)

6.1 GENERAL

The process for enforcement of Canada's *Aeronautics Act* came into force in 1986. This process includes powers of suspension, an administrative monetary penalty system and an independent tribunal to review the decisions made by the Minister of Transport.

This process was expanded on June 30, 2003, when the *Transportation Appeal Tribunal of Canada Act* and consequential amendments to the *Aeronautics Act* were proclaimed in force.

The new TATC has replaced the former Civil Aviation Tribunal and has expanded jurisdiction and authority. The new Tribunal has the authority to review the Minister's decisions with respect to Canadian aviation documents and the assessment of monetary penalties.

The Tribunal process applies to five types of administrative actions. One type of action is the refusal to issue or amend a Canadian aviation document. There are three types of actions that are related to the powers of suspension or cancellation of a Canadian aviation document, and the fifth type of action is the Minister's power to assess monetary penalties for the contravention of certain regulatory provisions. Decisions made by the Minister of Transport to take any of these administrative actions may be reviewed by a single member of the Tribunal and may be followed by an appeal to a three-member panel.

The purpose of this scheme is to provide those affected by administrative decisions with an opportunity for a fair hearing before an independent body. The TATC is not an agency of Transport Canada. It is composed of individuals with experience in many different aspects of the transportation industry. Its members who have aviation industry experience will hear aviation cases, as the need arises.

6.2 REFUSAL TO ISSUE OR AMEND A CANADIAN AVIATION DOCUMENT

The Minister's power to refuse to issue or amend a Canadian aviation document is set out in the amended *Aeronautics Act*. The four distinct grounds for the powers are as follows:

- (a) incompetence of the applicant for the document or amendment;
- (b) failure to meet the qualifications or fulfil the conditions necessary for the issuance or amendment of the document;
- (c) public interest reasons; and
- (d) failure by the applicant to pay monetary penalties for which the Tribunal has issued a certificate.

Where the Minister decides to refuse to issue or amend a Canadian aviation document, he must notify the applicant of his decision, the grounds for the decision and the specific reasons those grounds apply. The applicant has the right to request a review of the Minister's decision. The notice must inform the applicant of the steps they must follow to obtain a review.

At the review, the Tribunal will consider whether or not the Minister's decision is justified, based on the facts of the case. Both the applicant and the Minister will be given a full opportunity to present evidence and make representations with respect to the decision under review. The applicant may call their own witnesses and cross-examine those called by the Minister. They may also be represented by counsel or have another person appear on their behalf.

In making its determination at the review, the Tribunal may confirm the Minister's decision or, if it finds the decision is unjustified, it may refer the matter to the Minister for reconsideration.

6.3 SUSPENSION, CANCELLATION OR REFUSAL TO RENEW

The powers to suspend, cancel or refuse to renew a Canadian aviation document are set out in the amended *Aeronautics Act*. The four distinct grounds for the powers are as follows:

- (a) suspend or cancel for contravention of any provision in Part I of the Act or the regulations made under the Act [e.g. the Canadian Aviation Regulations (CARs)];
- (b) suspend on the grounds that an immediate threat to aviation safety exists or is likely to occur;
- (c) suspend, cancel or refuse to renew on the grounds of:
 - (i) incompetence,
 - (ii) ceasing to meet the qualifications or fulfil the conditions subject to which the document was issued (this includes medical grounds), or
 - (iii) public interest reasons; and
- (d) suspend or refuse to renew for failure to pay monetary penalties for which the Tribunal has issued a certificate of non-payment.

Where the Minister decides to suspend, cancel or refuse to renew a Canadian aviation document, he must notify the document holder. The notice must include his decision, the grounds for the decision and the specific reasons those grounds apply. The document holder has the right to request a review of the Minister's decision. The notice must also inform the applicant of the steps they must follow to obtain a review.

The review process and the Tribunal's authority are the same as outlined above, with only the following difference: in the case of a suspension or cancellation of a Canadian aviation document on the grounds that the holder of the document has contravened a provision of the Act or regulations, the Tribunal may confirm the Minister's decision or may substitute its own decision for that of the Minister.

6.4 MONETARY PENALTIES

The power to assess a monetary penalty applies only to those regulations referred to as "designated provisions." These are generally offences of a regulatory nature. They are designated and then listed in a schedule (CAR, Subpart 103). Where a person contravenes a designated provision, the Minister may assess an appropriate fine to be paid as a penalty for the contravention. A notice of assessment of monetary penalty is then sent informing the person that full payment of the penalty will end the matter. The notice must also inform the person of the steps they must follow to obtain a review.

In the event that full payment is not received within 30 days, and no request for a review is filed with the Tribunal, the person will be deemed to have committed the contravention and must pay the penalty assessed.

If the alleged offender requests a review hearing, the process of the hearing is the same as that set out above. The Tribunal has the authority to confirm the Minister’s decision to impose a penalty and its amount, or it may substitute its own decision for the Minister’s. If a contravention is confirmed, the Tribunal will inform both the Minister and the alleged offender of the decision and the amount of the penalty payable with respect to the contravention.

6.5 APPEALS

If a party fails to appear or be represented at a review hearing without sufficient reason to justify their absence, that party is not entitled to request an appeal of the determination.

A person affected by the Tribunal’s review determination may request an appeal of the determination. The Minister may also request an appeal of the Tribunal’s review determination with respect to a suspension or cancellation of a Canadian aviation document on the grounds of contravention of a provision of the Act or regulations or with respect to a monetary penalty. In all cases, the request for an appeal must be made within 30 days after the Tribunal’s review determination.

The appeal is on the merits of the decision and the appeal panel is limited to considering the record of the evidence introduced at the review hearing, other evidence that was not available at the review hearing and oral arguments by the parties. The appeal panel may allow the appeal or dismiss it. If the Tribunal allows the appeal, it may send the matter back to the Minister for reconsideration or, in the case of an alleged contravention or monetary penalty, the Tribunal may substitute its own decision for the review determination.

Further information with respect to procedures before the TATC may be obtained by consulting the *Transportation Appeal Tribunal of Canada Act*, the *Aeronautics Act* (sections 6.6 to 7.21 and 7.6 to 8.2), the Tribunal rules and CAR, Subpart 103.

The TATC may be contacted at:

Transportation Appeal Tribunal of Canada
333 Laurier Avenue West
12th Floor, Room 1201
Ottawa ON K1A 0N5

Tel.: 613-990-6906
Fax: 613-990-9153

7.0 CANADIAN AVIATION REGULATION ADVISORY COUNCIL (CARAC)

7.1 GENERAL

This document outlines the TCCA regulatory advisory committee process.

1. The name of the advisory committee is the “Canadian Aviation Regulation Advisory Council” (short title: CARAC).
2. The Director General, Civil Aviation (DGCA) is the sponsor of CARAC.
3. The effective date of the Council is July 1, 1993.

7.2 INTRODUCTION

Part I of the *Canadian Aviation Regulations* (CARs) requires that any standards that are made by the Minister, for incorporation by reference into the CARs, be subject to consultation with interested persons before they are established. The consultation must be conducted in accordance with the procedures set out in the *CARAC Management Charter and Procedures* (TP 11733). In addition, as a matter of policy, TCCA has decided to use CARAC for consultation on all aspects of its rulemaking activities.

7.3 GOVERNING PRINCIPLES

CARAC is a joint undertaking of government and the aviation community. Participation includes a large number of organizations outside TC, selected as representing the overall viewpoint of the aviation community. These include operators and manufacturers with management and labour represented, professional associations and consumer groups.

In the conduct of its activities, CARAC follows the objectives of the *Cabinet Directive on Streamlining Regulation*, published by the Regulatory Affairs Directorate of Treasury Board. The main theme of this document is to foster ongoing participation and consultation with the regulated aviation community.

All recommendations for change to the aviation regulatory system must be made with a view to maintain or improve aviation safety in Canada. New proposals are judged on the safety and efficiency that would result from their implementation.

Each CARAC member organization is represented by a delegate appointed by the member organization, who is authorized by the member organization to act on its behalf. In addition, each member organization may designate one or more alternate(s) for its appointed delegate.

7.4 OBJECTIVE

CARAC’s prime objective is to assess and recommend potential regulatory changes through co-operative rulemaking activities.

A Technical Committee has been established to provide advice and recommendations to the Civil Aviation Regulatory Committee (CARC) concerning the full range of TCCA’s rulemaking mandate. Technical Committee meetings are organized based on themes rather than on parts of the CARs.

Notwithstanding the above, CARAC activities do not replace the public rulemaking procedures mandated by the Regulatory Affairs Directorate of Treasury Board. Formal consultation on proposed regulations through the *Canada Gazette*, Part I continues.

7.5 ORGANIZATION STRUCTURE

The CARC, composed of TCCA senior executives, identifies and establishes the priority of regulatory issues, and considers and directs the implementation of recommendations made to them. The CARC also provides advice and recommendations to the TC Assistant Deputy Minister, Safety and Security.

The Technical Committee, with representation from both TCCA and the aviation community, reviews and analyzes the issues assigned by the CARC and makes regulatory recommendations.

To assist in its work, the Technical Committee may, from time to time, form working groups, with the approval of the CARC, to study a specific task. Working groups, composed of specialists representing both government and the aviation community, develop proposals and recommendations for the assigned tasks. Working groups report to the Technical Committee, as required, and are limited to the period required to complete the assigned task. For the purposes of a standing working group, the tasks may be separated and finalized without ending the mandate of the working group.

A Secretariat has been established and is responsible for the management of CARAC, on behalf of the CARC.

7.6 PROJECT RESOURCES

Apart from the full-time Secretariat, resource support is solicited from within TCCA and the aviation community, as required.

Costs incurred by organizations outside TC are expected to be borne by those organizations; however, TC will provide, where available, meeting facilities and secretariat support, such as minute taking.

7.7 COMMUNICATION AND EXTERNAL RELATIONSHIPS

Comprehensive and timely communications are to be given top priority. The extensive participation of representatives from the aviation community and from within TC in every facet of CARAC ensures a high level of communication with the aviation community.

The Secretariat’s communication strategy includes:

- (a) distribution of Technical Committee meeting information; and
- (b) a CARAC Web site, which can be viewed by accessing the TC home page at <www.tc.gc.ca> (see LRA 7.9 for additional details).

7.8 INFORMATION

The information presented herein is published in greater detail in the *CARAC Management Charter and Procedures* (TP 11733 E). Those interested in becoming CARAC members or wishing to obtain more information concerning CARAC may contact the CARAC Secretariat. The CARAC Secretariat is also interested in users’ comments or suggestions, which may be forwarded by e-mail or by mail to:

Transport Canada (AARBH)
 CARAC Secretariat
 330 Sparks Street
 Ottawa ON K1A 0N8
 Tel.: 613-990-1184
 Fax: 613-990-1198
 E-mail:services@tc.gc.ca

7.9 WEB SITE

CARAC’s Web site provides members with a means of obtaining regulatory documents and other related information published through CARAC.

The Internet meets CARAC’s communication strategy by giving top priority to comprehensive and timely communications. Everyone is invited to use TC’s Web site, which provides free, 24-hr service at <www.tc.gc.ca/>.

CARAC-related information can be found at: <www.tc.gc.ca/eng/civilaviation/regserv/affairs-carac-menu-755.htm>.



8.0 CIVIL AVIATION ISSUES REPORTING SYSTEM (CAIRS)

9.0 LRA ANNEX – AIRCRAFT AIRWORTHINESS

8.1 INTRODUCTION

TCCA has long recognized the benefits of receiving feedback from its stakeholders. To facilitate the reporting of complaints or concerns, TCCA had introduced the Complaint Handling Policy and Procedures. The former policy has now been replaced by the Civil Aviation Issues Reporting System (CAIRS). CAIRS expands the range of issues covered from complaints and concerns to also include compliments, recommendations and suggestions for improvement.

For further information, please refer to:

www.tc.gc.ca/eng/civilaviation/menu.htm, or contact:

CAIRS Coordinator
Transport Canada Civil Aviation
Place de Ville, Tower C, 5th floor
330 Sparks Street
Ottawa ON K1A 0N8

E-mail: CAIRS_NCR@tc.gc.ca

Tel.: 613-990-1493

9.1 GENERAL

All information concerning the approval of a type design or a change to the type design of an aeronautical product can be found in CAR 521, at www.tc.gc.ca/eng/civilaviation/regserv/cars/part5-subpart21-1798.htm.

Guidance material supporting this regulation can be found at www.tc.gc.ca/eng/civilaviation/opssvs/management/services-referencecentre-ac-500-521-002-1413.htm.

AIR – AIRMANSHIP

1.0 GENERAL INFORMATION

1.1 GENERAL

Airmanship is the application of flying knowledge, skill and experience which fosters safe and efficient flying operations. Airmanship is acquired through experience and knowledge. This section contains information and advice on various topics which help to increase knowledge.

1.2 PILOT VITAL ACTION CHECKLISTS

A number of aircraft accidents have been directly attributed to the lack of proper vital action checks by the pilots concerned. It is essential that pretakeoff, prelanding and other necessary vital action checks be performed with care.

While Transport Canada does not prescribe standard checks to be performed by pilots, it is strongly recommended that owners equip their aircraft with the manufacturer’s recommended checklists. For any specific type of aircraft, only relevant items should be included in the checklists which should be arranged in an orderly sequence having regard to the cockpit layout.

1.3 AVIATION FUELS

1.3.1 Fuel Grades

The use of aviation fuel other than specified is contrary to a condition of the Certificate of Airworthiness and, therefore, a contravention of regulations. A fuel which does not meet the specifications recommended for the aircraft may seriously damage the engine and result in an inflight failure. In Canada, fuels are controlled by government specifications. Aviation fuel can usually be identified by its colour.

FUEL	COLOUR
AVGAS 80/87	red
AVGAS 100/130	green
100 LL	blue
Aviation Turbine Fuels	straw-coloured or undyed
MOGAS P 87-90 (see NOTE 2)	green
MOGAS R 84-87 (see NOTE 2)	undyed

NOTES 1: Good airmanship ensures that positive identification of the type and grade of aviation fuel is established before fuelling.

2: Transport Canada now approves the use of automotive gasoline for certain aircraft types under specific conditions. For additional information, refer to TP 10737E – *Use of Automotive Gasoline (MOGAS) for General Aviation Aircraft*, available from your TC Airworthiness Regional office. (See GEN 1.1.2 for addresses.)

1.3.2 Aviation Fuel Handling

A company supplying aviation fuel for use in civil aircraft is responsible for the quality and specifications of its products up to the point of actual delivery. Following delivery, the operator is responsible for the correct storage, handling, and usage of aviation fuel. A fuel dispensing system must have an approved filter, water separator or monitor to prevent water or sediment from entering aircraft fuel tanks. The use of temporary fuelling facilities such as drums or cans is discouraged. However, if such facilities are necessary, always filter aviation fuel using a proper filter and water separator with a portable pump bonded to the drum before bungs are removed.

The aircraft and fuelling equipment through which fuel passes all require bonding. The hose nozzle must be bonded to the aircraft before the tank cap is removed in over-wing fuelling. All funnels or filters used in fuelling are to be bonded together with the aircraft. Bonding prevents sparks by equalizing or draining the electric potentials.

During the preflight check, a reasonable quantity of fuel should be drawn from the lowest point in the fuel system into a clear glass jar. A “clear and bright” visual test should be made to establish that the fuel is completely free of visible solid contamination and water (including any resting on the bottom or sides of the container), and that the fuel possesses an inherent brilliance and sparkle in the presence of light. Cloudy or hazy fuel is usually caused by free and dispersed water, but can also occur because of finely divided dirt particles. Free water may also be detected by the use of water-finding paste available from oil companies. If there is any suspicion that water exists in an aircraft’s fuel system detailed checking of the entire system should be carried out until it is proven clear of contamination. Analysis by an approved laboratory is the only way to ensure positive proof of compliance if doubt exists.

1.3.3 Fuel Anti-Icing Additives

All aviation fuels absorb moisture from the air and contain water in both suspended particles and liquid form. The amount of suspended particles varies with the temperature of the fuel. When the temperature of the fuel is decreased, some of the suspended particles are drawn out of the solution and slowly fall to the bottom on the tank. When the temperature of the fuel increases, water particles from the atmosphere are absorbed to maintain a saturated solution.

AIR

As stated in AIR 1.3.2, water should be drained from aircraft fuel systems before flight. However, even with this precaution water particles in suspension will remain in the fuel. While this is not normally a problem it becomes so when fuel cools to the freezing level of water and the water particles change to ice crystals. These may accumulate in fuel filters, bends in fuel lines, and in some fuel-selectors and eventually may block the fuel line causing an engine stoppage. Fuel anti-icing additives will inhibit ice crystal formation. Manufacturer approved additives, such as ethylene-glycol-monomethyl-ether (EGME), used in the prescribed manner have proven quite successful. The aircraft manufacturer's instructions for the use of anti-icing fuel additives should therefore be consulted and carefully followed.

1.3.4 Fires and Explosions

Pound for pound aviation fuel is more explosive than dynamite. However, the explosive range of fuel is comparatively narrow. To be explosive, the mixture must contain 1 to 6% fuel vapor by volume when combined with air. Mixtures below this range are too weak and those above are too rich to explode.

The mixture in the space above the fuel in a gas-tight compartment is usually too rich for combustion, but in extremely cold conditions there may be a mixture lean enough to be explosive.

In sub-freezing weather conditions static charges can build up more readily than in warmer conditions. Untreated turbo fuel, when agitated as in refuelling operations, can build up greater static electricity charges than gasoline and is therefore, under certain conditions, potentially more dangerous. Most turbo fuel supplied in Canada contains an anti-static additive.

To avoid fires and explosions there should be effective electrical bonding between the aircraft, the fuel source, piping or funnel and the ground before refuelling is undertaken.

- NOTES** 1: Incidents have occurred involving death and injury resulting from fuelling in enclosed spaces, and with inadequate bonding. At low temperatures and humidity, a blower-heater could build up statically-charged dust particles to combine with fuel vapours with catastrophic results.
- 2: The increasing use of small plastic fuel containers which cannot be properly bonded or grounded increases the chance of explosion and fire.

1.4 AIRCRAFT HAND FIRE EXTINGUISHERS

1.4.1 General

When selecting a hand fire extinguisher for use in aircraft, consider the most appropriate extinguishing agent for the type and location of fires likely to be encountered. Take account of the agent's toxicity, extinguishing ability, corrosive properties, freezing point, etc.

The toxicity ratings listed by the Underwriters' Laboratories for some of the commonly known fire extinguisher chemicals are as follows:

- Bromotrifluoromethane (Halon 1301) – Group 6
- Bromochlorodifluoromethane (Halon 1211) – Group 5a
- Carbon dioxide – Group 5a
- Common Dry Chemicals – Group 5a
- Dibromodifluoromethane (Halon 1202) – Group 4*
- Bromochloromethane (Halon 1011) – Group 4*
- Carbon Tetrachloride (Halon 104) – Group 3*
- Methyl bromide (Halon 1001) – Group 2*

*Should not be installed in an aircraft

It is generally realized that virtually any fire extinguishing agent is a compromise between the hazards of fire, smoke, fumes and a possible increase in hazard due to the toxicity of the extinguishing agent used. Hand fire extinguishers using agents having a rating in toxicity Groups 2 to 4 inclusive should not be installed in aircraft. Extinguishers in some of the older types of aircraft do not meet this standard and for such aircraft it is recommended that hand fire extinguishers employing agents in toxicity Group 5 or above be installed when renewing or replacing units and that they be of a type and group approved by the Underwriters' Laboratories. It is further recommended that instruction in the proper use, care and cautions to be followed be obtained from the manufacturer and the local fire protection agency.

1.4.2 Classification of Fires

<i>Class A fires:</i>	Fires in ordinary combustible materials. On these, water or solutions containing large percentages of water are most effective.
<i>Class B fires:</i>	Fires in flammable liquids, greases, etc. On these a blanketing effect is essential.
<i>Class C fires:</i>	Fires in electrical equipment. On these the use of a nonconducting extinguishing agent is of first importance.

1.4.3 Types of Extinguishers

1. *Carbon Dioxide Extinguishers:* Carbon dioxide extinguishers are acceptable when the principal hazard is a Class B or Class C fire. Carbon dioxide portable installations should not exceed five pounds of agent per unit to ensure extinguisher portability and to minimize crew compartment CO₂ concentrations.
2. *Water Extinguishers:* Water extinguishers are acceptable when the principal hazard is a Class A fire and where a fire might smolder if attacked solely by such agents as carbon dioxide or dry chemical. If water extinguishers will be subject to temperatures below freezing, the water extinguisher must be winterized by addition of a suitable anti-freeze.
3. *Vaporizing Liquid Extinguishers:* Vaporizing liquid type fire extinguishers are acceptable when the principal hazard is a Class B or Class C fire.
4. *Dry Chemical Extinguishers:* Dry chemical extinguishers using a bi-carbonate of sodium extinguishing agent or potassium bi-carbonate powder are acceptable where the principal hazard is a Class B or Class C fire.

Dry chemical extinguishers using a so-called All Purpose Monoammonium Phosphate are acceptable where the hazard includes a Class A fire as well as Class B and Class C.

The size of the dry chemical extinguisher should not be less than two lbs. Only an extinguisher with a nozzle that can be operated either intermittently or totally by the operator should be installed.

Some abrasion or corrosion of the insulation on electrical instruments, contacts or wiring may take place as a result of using this extinguisher. Cleaning and inspection of components should be carried out as soon as possible.

Care should be taken when using this extinguisher in crew compartments because the chemical can interfere with visibility while it is being used and because the nonconductive powders may be deposited on electrical contacts not involved in the fire. This can cause equipment failure.

5. *Halon Extinguishers:* Halon 1211 is a colourless liquefied gas which evaporates rapidly, does not freeze or cause cold burn, does not stain fabrics nor cause corrosive damage. It is equally effective on an A, B or C class fire and has proven to be the most effective extinguishant on gasoline based upholstery fires. The size of a Halon 1211 extinguisher for a given cubic space should not result in a concentration of more than 5%. Halon 1211 is at least twice as effective as CO₂ and is heavier than air (so it “sinks”). Decomposed Halon 1211 “stinks” so it is not likely to be breathed unknowingly.

Halon 1301 is less toxic than Halon 1211 but it is also less effective and is excellent for B or C class fires. A short-coming appears to be the lack of a visible “stream” on discharge; Halon 1301 turns into an invisible gas as it discharges.

1.5 PRESSURE ALTIMETER

1.5.1 General

The pressure altimeter used in aircraft is a relatively accurate instrument for measuring flight level pressure but the altitude information indicated by an altimeter, although technically “correct” as a measure of pressure, may differ greatly from the actual height of the aircraft above mean sea level or above ground. In instances of aircraft flying high above the earth’s surface, knowledge of the actual distance between the aircraft and the earth’s surface is of little immediate value to the pilot except, perhaps, when navigating by pressure pattern techniques. In instances of aircraft operating close to the ground or above the highest obstacle en route, especially when on instruments, knowledge of actual ground separation or of “error” in the altimeter indication, is of prime importance if such separation is less than what would be assumed from the indicated altitude.

An aircraft altimeter which has the current altimeter setting applied to the subscale should not have an error of more than ±50 feet when compared on the ground against a known aerodrome or runway elevation. If the error is more than ±50 feet, the altimeter should be checked by maintenance as referenced in AIR 1.5.2.

1.5.2 Calibration of the Pressure Altimeter

Pressure altimeters are calibrated to indicate the “true” altitude in the ICAO Standard Atmosphere. The maximum allowable tolerance is ±20 feet at sea level for a calibrated altimeter. This tolerance increases with altitude.

The ICAO Standard Atmosphere conditions are:

- (a) air is a perfectly dry gas;
- (b) mean sea level pressure of 29.92 inches of mercury;
- (c) mean sea level temperature of 15°C; and
- (d) rate of decrease of temperature with height is 1.98°C per 1 000 feet to the height at which the temperature becomes -56.5°C and then remains constant.

1.5.3 Incorrect Setting on the Subscale of the Altimeter

Although altimeters are calibrated using the Standard Atmosphere sea level pressure of 29.92 inches of mercury, the actual sea level pressure varies hour to hour, and place to place. To enable the “zero” reference to be correctly set for sea level at any pressure within a range of 28.0 to 31.0 inches of mercury, altimeters incorporate a controllable device and subscale. Whether a pilot inadvertently sets an incorrect pressure on the altimeter subscale or sets the correct pressure for one area and then, without altering the setting, flies to an area where the pressure differs, the result is the same – the “zero” reference to the altimeter will not be where it should be but will be “displaced” by an amount proportional to 1 000 feet indicated altitude per 1 inch of mercury that the subscale setting is in error. As pressure decreases with altitude, a subscale setting that is higher than it should be will “start” the altimeter at a lower level, therefore, **A TOO HIGH SUBSCALE SETTING MEANS A TOO HIGH ALTIMETER READING**, that is the aircraft would be at a level lower than the altimeter indicates; **A TOO LOW SUBSCALE SETTING MEANS A TOO LOW ALTIMETER READING**, that is the aircraft would be at a level higher than the altimeter indicates. As the first instance is the more dangerous, an example follows:

A pilot at Airport A, 500 feet ASL, sets the altimeter to the airport’s altimeter setting of 29.80 inches of mercury prior to departure for Airport B, 1 000 feet ASL, some 400 NM away. A flight altitude of 6 000 feet is selected for the westbound flight so as to clear a 4 800-foot mountain ridge lying across track about 40 NM from B. The pilot does not change the altimeter subscale reading until he makes radio contact with B when 25 NM out and receives an altimeter setting of 29.20 inches of mercury. Ignoring other possible errors (see below), when the aircraft crossed the mountain ridge the actual ground clearance was only 600 feet, not 1 200 feet as expected by the pilot. This illustrates the importance of having the altimeter setting of the nearest airport along the route set on the instrument.

1.5.4 Non-Standard Temperatures

- (a) The only time that an altimeter will indicate the “true” altitude of an aircraft at all levels is when ICAO Standard Atmosphere conditions exist.
- (b) When the current altimeter setting of an airport is set on the subscale of an altimeter, the only time a pilot can be certain that the altimeter indicates the “true” altitude is when the aircraft is on the ground at that airport.
- (c) When 29.92 inches of mercury is set on the subscale of an altimeter within the Standard Pressure Setting Region, the altimeter will indicate “true” altitude if ICAO Standard Atmosphere conditions exist or if the aircraft is flying at that particular level for which 29.92 inches of mercury would be the altimeter setting.

In general, it can be assumed that the altitude indication of an altimeter is always in error due to temperature when an aircraft is in flight.

The amount of error will be approximately 4% of the indicated altitude for every 11°C that the average temperature of the air column between the aircraft and the “ground” differs from the average temperature of the Standard Atmosphere for the same air column. In practice, the average temperature of the air column is not known and “true” altitude is arrived at from knowledge of the outside air temperature (OAT) at flight level and use of a computer. The “true” altitude found by this method will be reasonably accurate when the actual lapse rate is, or is near, that of the Standard Atmosphere, i.e., 2°C per 1 000 feet. During the winter when “strong” inversions in the lower levels are likely and altimeters “habitually” over-read, in any situation where ground separation is marginal, a pilot would be well advised to increase the altimeter error found using flight level temperature by 50%. Consider the aircraft in the above example; assume that the OAT at flight level in the vicinity of the mountain ridge was -20°C; what was the likely “true” altitude of the aircraft over the mountain ridge?

To calculate “true” altitude using a computer, the pressure altitude is required. In this case, the altimeter indicates 6 000 feet with 29.80 inches of mercury set on the subscale, therefore, if the pilot altered the subscale to 29.92 inches of mercury momentarily, the pilot would read a pressure altitude of 6 120 feet. Although the indicated altitude is 6 000 feet, if the altimeter setting of the nearest airport (B) was set, the indicated altitude would be 5 400 feet. With 29.20 inches of mercury set on the altimeter subscale if the aircraft was on the ground at B, the altimeter would indicate the “true” altitude of 1 000 feet; assuming no pressure difference, it can be taken that the altimeter set to 29.20 inches of mercury would indicate the 1 000-foot level at the mountain with no error due to temperature, therefore temperature error will occur only between the 1 000-foot level and the 5 400-foot level, i.e., 4 400 feet of airspace.

- (a) Set pressure altitude, 6 120 feet, against OAT, -20°C, in the appropriate computer window.
- (b) Opposite 4 400 feet (44) on the inner scale read 4 020 feet (40.2) on the outer scale.
- (c) Add the 1 000 feet previously deducted as being errorless and find the “true” altitude of 4 020 feet + 1 000 feet = 5 020 feet ASL. The margin of safety is now just over 200 feet, but this does not take into account variables which may prevail as outlined immediately above and due to mountain effect as explained below.

1.5.5 Standard Pressure Region

When flying within this region, the altimeter must be reset, momentarily, to the altimeter setting of the nearest airport along the route to obtain indicated altitude, or indicated altitude calculated from the altimeter setting, and the steps given above followed, or, when over large expanses of water or barren lands where there are no airports, the forecast mean sea level pressure for the time and place must be used to get indicated altitude. In the other instance, “airport” level would be zero, therefore subtraction and addition of airport elevation would not be done. The “true” altitude determined in such a case would be “true” only if the forecast pressure used approximates the actual sea level pressure. (If sea level pressure is not known and pressure altitude is used also as indicated altitude, the resultant “true” altitude will be the “true” altitude above the 29.92 level, wherever it may be in relation to actual mean sea level).

1.5.6 Effect of Mountains

Winds which are deflected around large single mountain peaks or through the valleys of mountain ranges tend to increase speed which results in a local decrease in pressure (Bernoulli’s Principle). A pressure altimeter within such an airflow would be subject to an increased error in altitude indication by reason of this decrease in pressure. This error will be present until the airflow returns to “normal” speed some distance away from the mountain or mountain range.

Winds blowing over a mountain range at speeds in excess of about 50 KT and in a direction perpendicular (within 30°) to the main axis of the mountain range often create the phenomena known as “Mountain” or “Standing Wave”. The effect of a mountain wave often extends as far as 100 NM downwind of the mountains and to altitudes many times higher than the mountain elevation. Although most likely to occur in the vicinity of high mountain ranges such as the Rockies, mountain waves have occurred in the Appalachians, elevation about 4 500 feet ASL (the height of the ridge of our example).

Aware and the *Air Command Weather Manual* (TP 9352E) cover the mountain wave phenomena in some detail; however, aspects directly affecting aircraft “altitude” follow.

1.5.7 Downdraft and Turbulence

Downdrafts are most severe near a mountain and at about the same height as the top of the summit. These downdrafts may reach an intensity of about 83 ft. per second (5 000 ft. per minute) to the lee of high mountain ranges, such as the Rockies. Although mountain waves often generate severe turbulence, at times flight through waves may be remarkably “smooth” even when the intensity of downdrafts and updrafts is considerable. As these smooth conditions may occur at night, or when an overcast exists, or when no distinctive cloud has formed, the danger to aircraft is enhanced by the lack of warning of the unusual flight conditions.

Consider the circumstances of an aircraft flying parallel to a mountain ridge on the downwind side and entering a smooth downdraft. Although the aircraft starts descending because of the downdraft, as a result of the local drop in pressure associated with the wave, both the rate of climb indicator and the altimeter will not indicate a descent until the aircraft actually descends through a layer equal to the altimeter error caused by the mountain wave, and, in fact, both instruments may actually indicate a “climb” for part of this descent; thus the fact that the aircraft is in a downdraft may not be recognized until after the aircraft passes through the original flight pressure level which, in the downdraft, is closer to the ground than previous to entering the wave.

1.5.8 Pressure Drop

The “drop” in pressure associated with the increase in wind speeds extends throughout the mountain wave, that is downwind and to “heights” well above the mountains. Isolating the altimeter error caused solely by the mountain wave from error caused by non-standard temperatures would be of little value to a pilot. Of main importance is that the combination of mountain waves and non-standard temperature may result IN AN ALTIMETER OVERREADING BY AS MUCH AS 3 000 FT. If the aircraft in our example had been flying upwind on a windy day, the actual ground separation on passing over the crest of the ridge may well have been very small.

1.5.9 Abnormally High Altimeter Settings

Cold dry air masses can produce barometric pressures in excess of 31.00 in. of mercury. Because barometric readings of 31.00 in. of mercury or higher rarely occur, most standard altimeters do not permit setting of barometric pressures above that level and are not calibrated to indicate accurate aircraft altitude above 31.00 in. of mercury. As a result, most aircraft altimeters cannot be set to provide accurate altitude readouts to the pilot in these situations.

When aircraft operate in areas where the altimeter setting is in excess of 31.00 in. of mercury and the aircraft altimeter cannot be set above 31.00 in. of mercury, the true altitude of the aircraft will be HIGHER than the indicated altitude.

Procedures for conducting flight operations in areas of abnormally high altimeter settings are detailed in RAC 12.12.

1.6 CANADIAN RUNWAY FRICTION INDEX (CFRI)

1.6.1 General

The following paragraphs discuss the slippery runway problem and suggest methods of applying runway coefficient of friction information to aircraft flight manual (AFM) data.

1.6.2 Reduced Runway Coefficients of Friction and Aircraft Performance

The accelerate-stop distance, landing distance and crosswind limitations (if applicable) contained in the aircraft flight manual (AFM) are demonstrated in accordance with specified performance criteria on runways that are bare, dry, and that have high surface friction characteristics. Unless some factor has been applied, these distances are only valid under similar runway conditions. Whenever a contaminant—such as water, snow or ice—is introduced to the runway surface, the effective coefficient of friction between the aircraft tire and runway is substantially reduced. The stop portion of the accelerate-stop distance will increase, the landing distance will increase and a crosswind may present directional control difficulties. The problem has been to identify, with some accuracy, the effect that the contaminant has had on reducing the runway coefficient of friction and to provide meaningful information to the pilot, e.g. how much more runway is needed to stop and what maximum crosswind can be accepted.

1.6.3 Description of CRFI and Method of Measurement

The decelerometer is an instrument mounted in a test vehicle that measures the decelerating forces acting on the vehicle when the brakes are applied. The instrument is graduated in increments from 0 to 1, the highest number being equivalent to the theoretical maximum decelerating capability of the vehicle on a dry surface. These numbers are referred to as the CRFI. It is evident that small numbers represent low braking coefficients of friction while numbers on the order of 0.8 and above indicate the braking coefficients to be expected on bare and dry runways.

The brakes are applied on the test vehicle at 300-m (1 000-ft) intervals along the runway within a distance of 10 m (30 ft) from each side of the runway centreline at that distance from the centreline where the majority of aircraft operations take place at each given site. The readings taken are averaged and reported as the CRFI number.

1.6.4 Aircraft Movement Surface Condition Reports (AMSCR)

AMSCRs are issued to alert pilots of natural surface contaminants—such as snow, ice or slush—that could affect aircraft braking performance. The RSC section of the report provides information describing the runway condition in plain language, while the CRFI section describes braking action quantitatively using the numerical format described in AIR 1.6.3.

Because of mechanical and operational limitations, runway friction readings produced by decelerometer devices may result in inaccurate readings under certain surface conditions. As a result, runway friction readings will not be taken and a CRFI will not be provided to ATS or pilots when any of the following conditions are present:

- (a) the runway surface is simply wet with no other type of contamination present;
- (b) there is a layer of slush on the runway surface with no other type of contamination present; or
- (c) there is dry snow on the runway surface exceeding 2.5 cm (1 in.) in depth.

An RSC report must be provided when:

- (a) there is frost, snow, slush or ice on a runway;
- (b) there are snow banks, drifts or windrows on or adjacent to a runway;
- (c) sand, aggregate material, anti-icing or de-icing chemicals are applied to a runway;
- (d) the cleared runway width falls below the published width;
- (e) the runway lights are obscured or partially obscured by contaminants;
- (f) there is a significant change in runway surface conditions including a return to bare and dry conditions; or
- (g) as per the required minimum inspection frequency.

The following changes relating to runway conditions are considered significant:

- (a) a change of 0.05 or more in the coefficient of friction;
- (b) changes in depth of deposit greater than 20 mm (0.79 in.) for dry snow, 10 mm (0.4 in.) for wet snow, 3 mm (0.13 in.) for slush;
- (c) a change in the cleared width of a runway of 10 percent or more;
- (d) any change in the type of deposit or extent of coverage, including a return to bare and dry conditions;
- (e) any change in the height of snow banks or their distance from the centreline on one or both sides of the runway;
- (f) any change in the visibility of runway lighting because the lights are obscured by contaminants; and
- (g) any other conditions that are, in the opinion of the aerodrome authority, considered to be significant.

When available, a CRFI reading will be issued along with the RSC in order to provide an overall descriptive picture of the runway condition and to quantify braking action. The CRFI is to be reported whenever:

- (a) there is ice or frost on the runway;
- (b) there is wet ice on the runway;
- (c) there is slush over the ice on the runway;
- (d) sand, aggregate material, anti-icing or de-icing chemicals are applied to the runway;
- (e) there is a chemical solution on the ice on the runway;
- (f) there is compacted snow on the runway; or
- (g) there is dry snow not exceeding a depth of 2.5 cm (1 in.) on the runway.

When a deposit is present but the depth is not measurable, the word “TRACE” shall be used. Otherwise, the depth is expressed in inches or feet or both. When the depth is above 2 in, whole values are used. When the depth is less than 2 in, the decimal system is used. The accepted decimal values are 0.13, 0.25, 0.5, 0.75 and 1.5; however, caution has to be exercised as these values could be confused with CRFI measurements.

When clearing is not underway or expected to begin within the next 30 min, a notation such as “Clearing expected to start at (time in UTC)” will be added to the RSC report. When the meteorological conditions cause runway surface conditions to change frequently, the NOTAMJ will include the agency and telephone number to contact for the current runway conditions.

The full range of RSC/CRFI information will be available as a voice advisory from the control tower at controlled aerodromes and from the FSS at uncontrolled aerodromes.

Each new NOTAMJ (AMSCR report) issued supersedes the previous report for that aerodrome. A NOTAMJ is valid for 24 hr, based on the most recent observation of either the RSC or CRFI, after which time it is removed from the database by way of cancellation. A NOTAMJ may also be cancelled if the reporting requirements are no longer met or the NOTAMJ was issued in error.

NOTE: The absence of a NOTAMJ in no way indicates that runway conditions are acceptable for operations.

The format of the CRFI portion of the report is as follows: location indicator, title (CRFI), runway number, temperature (in degrees Celsius), runway average CRFI reading, and time (UTC) when readings were taken (using a ten-digit time group in the year-month-day-hour-minute [YYMMDDHHMM] format).

Examples of RSC and CRFI reports for paved runways:

- (a) CYND RSC 09/27 100 PCT DRY SN 4 INS 1101190630
RMK: CLEARING EXP TO START AT 1101191000
- (b) CYFB RSC 17/35 100 PCT DRY SN ON ICE 0.5 INS
1101190630 CYFB CRFI 17/35 -22C .34 1101190630
- (c) CYFB RSC 17/35 10 PCT SN DRIFTS 2 INS, 90 PCT
BARE AND DRY 1101191050
CYFB CRFI 17/35 -10C .30 1101191055
- (d) CYHZ RSC 05/23 160 FT CL 40 PCT COMPACTED
SN, 60 PCT FROST. REMAINING WID 80 PCT
COMPACTED SN, 20 PERCENT FROST. RMK:
SANDED 100 FT CL. 1102131240 CYHZ CRFI 05/23 0C
.22 1102131234
CYHZ RSC 14/32 160 FT CL 20 PCT COMPACTED SN,
80 PCT FROST.
REMAINING WID 80 PCT COMPACTED SN, 20 PCT
FROST. RMK: SANDED 100 FT CL 1102131240 CYHZ
CRFI 14/32 0C .29 1102131210
- (e) CYFB RSC CANCELLED
- (f) CYND RSC RWY COND CHANGING RAPIDLY. CTC
OPR (555) 555-5555 1102131240

Examples of RSC and CRFI reports for gravel runways:

- (a) CYBK RSC 16/34 100 PCT 0.5 INS DRY SN ON
COMPACTED SN 1112190640
CYBK CRFI 16/34 -22C .30 0112190645
- (b) CYGX RSC 05/23 100 PCT COMPACTED SN GRVL
MIX 1112210740
CYGX CRFI 05/23 -8C .39 1112210745
- (c) CYGW RSC 04/22 100 PCT 0.5 INS WET SN ON ICE
1112220630 CYGW CRFI 04/22 -14C
.18 1112220635

A NOTAMJ is issued based on reporting requirements rather than on dissemination criteria. Therefore, conditions such as “100 percent bare and dry”, “bare and damp”, or “bare and wet” will be disseminated if reported.

Information on taxiways and aprons, although not mandatory, can be disseminated in a NOTAMJ if deemed to have an impact on safe operations.

AIR

1.6.5 Wet Runways

Runway friction values are currently not provided during the summer and when it is raining. Consequently, some discussion of wet runways is in order to assist pilots in developing handling procedures when these conditions are encountered.

A packed-snow or ice condition at a fixed temperature presents a relatively constant coefficient of friction with speed, but this is not the case for a liquid (water or slush) state. This is because water cannot be completely squeezed out from between the tire and the runway and, as a result, there is only partial tire-to-runway contact. As the aircraft speed is increased, the time in contact is reduced further, thus braking friction coefficients on wet surfaces fall as the speed increases, i.e. the conditions in effect become relatively more slippery, but will improve again as the aircraft slows down. The situation is further complicated by the susceptibility of aircraft tires to hydroplane on wet runways.

Hydroplaning is a function of the water depth, tire pressure and speed. Moreover, the minimum speed at which a non-rotating tire will begin to hydroplane is lower than the speed at which a rotating tire will begin to hydroplane because a build up of water under the non-rotating tire increases the hydroplaning effect. Pilots should therefore be aware of this since it will result in a substantial difference between the take-off and landing roll aircraft performance under the same runway conditions. The minimum speed, in knots, at which hydroplaning will commence can be calculated by multiplying the square root of the tire pressure (PSI) by 7.7 for a non-rotating tire, or by 9 for a rotating tire.

This equation gives an approximation of the minimum speed necessary to hydroplane on a smooth, wet surface with tires that are bald or have no tread. For example, the minimum hydroplaning speeds for an aircraft with tires inflated to 49 PSI are calculated as:

Non-rotating tire: $7.7 \times \sqrt{49} = 54$ kt; or
Rotating tire: $9 \times \sqrt{49} = 63$ kt

When hydroplaning occurs, the aircraft's tires are completely separated from the actual runway surface by a thin water film and they will continue to hydroplane until a reduction in speed permits the tires to regain contact with the runway. This speed will be considerably lower than the speed at which hydroplaning commences. Under these conditions, the tire traction drops to almost negligible values, and in some cases, the wheel will stop rotating entirely. The tires will provide no braking capability and will not contribute to the directional control of the aircraft. The resultant increase in stopping distance is impossible to predict accurately, but it has been estimated to increase as much as 700 percent. Further, it is known that a 10-kt crosswind will drift an aircraft off the side of a 200-ft wide runway in approximately 7 sec under hydroplaning conditions.

Notwithstanding the fact that friction values cannot be given for a wet runway and that hydroplaning can cause pilots serious difficulties, it has been found that the well-drained runways at most major Canadian airports seldom allow pooling of sufficient water for hydroplaning to occur. The wet condition associated with rain may produce friction values on the order of a CRFI of 0.3 on a poorly maintained or poorly drained runway, but normally produces a value of 0.5. These figures can be used as a guide in conjunction with pilot and other reports.

1.6.6 CRFI Application to Aircraft Performance

The information contained in Tables 1 and 2 has been compiled and is considered to be the best data available at this time because it is based upon extensive field test performance data of aircraft braking on winter-contaminated surfaces. The information should provide a useful guide to pilots when estimating aircraft performance under adverse runway conditions. The onus for the production of information, guidance or advice on the operation of aircraft on a wet and/or contaminated runway rests with the aircraft manufacturer. The information published in the TC AIM does not change, create any additional, authorize changes in, or permit deviations from regulatory requirements. These Tables are intended to be used at the pilot's discretion.

Because of the many variables associated with computing accelerate-stop distances and balanced field lengths, it has not been possible to reduce the available data to the point where CRFI corrections can be provided, which would be applicable to all types of operations. Consequently, only corrections for landing distances and crosswinds are included pending further study of the take-off problem.

It should be noted that in all cases the Tables are based on corrections to aircraft flight manual (AFM) dry runway data and that the certification criteria does not allow consideration of the extra decelerating forces provided by reverse thrust or propeller reversing. On dry runways, thrust reversers provide only a small portion of the total decelerating forces when compared to wheel braking. However, as wheel braking becomes less effective, the portion of the stopping distance attributable to thrust reversing becomes greater. For this reason, if reversing is employed when a low CRFI is reported, a comparison of the actual stopping distance with that shown in Table 1 will make the estimates appear overly conservative. Nevertheless, there are circumstances—such as crosswind conditions, engine out situations or reverser malfunctions—that may preclude their use.

Landing distances recommended in Table 1 are intended to be used for aeroplanes with no discing and/or reverse thrust capability and are based on statistical variation measured during actual flight tests.

Notwithstanding the above comments on the use of discing and/or reverse thrust, Table 2 may be used for aeroplanes with discing and/or reverse thrust capability and is based on the landing distances recommended in Table 1 with additional calculations that give credit for discing and/or reverse thrust. In calculating the distances in Table 2, the air distance from

the screen height of 50 ft to touchdown and the delay distance from touchdown to the application of full braking remain unchanged from Table 1. The effects of discing and/or reverse thrust were used only to reduce the stopping distance from the application of full braking to a complete stop.

The recommended landing distances stated in Table 2 take into account the reduction in landing distances obtained with the use of discing and/or reverse thrust capability for a turboprop-powered aeroplane and with the use of reverse thrust for a turbojet-powered aeroplane. Representative low values of

discing and/or reverse thrust effect have been assumed and, therefore, the data may be conservative for properly executed landings by some aeroplanes with highly effective discing and/or thrust reversing systems.

The crosswind limits for CRFI shown in Table 3 contain a slightly different display range of runway friction index values from those listed in Tables 1 and 2. However, the CRFI values used for Table 3 are exactly the same as those used for Tables 1 and 2 and are appropriate for the index value increments indicated for the index value increments indicated.

Table 1—CRFI Recommended Landing Distances (No Discing/Reverse Thrust)

Reported Canadian Runway Friction Index (CRFI)														
Landing Distance (ft) Bare and Dry	0.60	0.55	0.50	0.45	0.40	0.35	0.30	0.27	0.25	0.22	0.20	0.18	Landing Field Length (ft) Bare and Dry	Landing Field Length (ft) Bare and Dry
Unfactored	Recommended Landing Distances (no Discing/Reverse Thrust)												60% Factor	70% Factor
1 800	3 120	3 200	3 300	3 410	3 540	3 700	3 900	4 040	4 150	4 330	4 470	4 620	3 000	2 571
2 000	3 480	3 580	3 690	3 830	3 980	4 170	4 410	4 570	4 700	4 910	5 070	5 250	3 333	2 857
2 200	3 720	3 830	3 960	4 110	4 280	4 500	4 750	4 940	5 080	5 310	5 490	5 700	3 667	3 143
2 400	4 100	4 230	4 370	4 540	4 740	4 980	5 260	5 470	5 620	5 880	6 080	6 300	4 000	3 429
2 600	4 450	4 590	4 750	4 940	5 160	5 420	5 740	5 960	6 130	6 410	6 630	6 870	4 333	3 714
2 800	4 760	4 910	5 090	5 290	5 530	5 810	6 150	6 390	6 570	6 880	7 110	7 360	4 667	4 000
3 000	5 070	5 240	5 430	5 650	5 910	6 220	6 590	6 860	7 060	7 390	7 640	7 920	5 000	4 286
3 200	5 450	5 630	5 840	6 090	6 370	6 720	7 130	7 420	7 640	8 010	8 290	8 600	5 333	4 571
3 400	5 740	5 940	6 170	6 430	6 740	7 110	7 550	7 870	8 100	8 500	8 800	9 130	5 667	4 857
3 600	6 050	6 260	6 500	6 780	7 120	7 510	7 990	8 330	8 580	9 000	9 320	9 680	6 000	5 143
3 800	6 340	6 570	6 830	7 130	7 480	7 900	8 410	8 770	9 040	9 490	9 840	10 220	6 333	5 429
4 000	6 550	6 780	7 050	7 370	7 730	8 170	8 700	9 080	9 360	9 830	10 180	10 580	6 667	5 714

Application of the CRFI

1. The recommended landing distances in Table 1 are based on a 95 percent level of confidence. A 95 percent level of confidence means that in more than 19 landings out of 20, the stated distance in Table 1 will be conservative for properly executed landings with all systems serviceable on runway surfaces with the reported CRFI.
2. Table 1 will also be conservative for turbojet- and turboprop-powered aeroplanes with reverse thrust, and additionally, in the case of turboprop-powered aeroplanes, with the effect obtained from discing.
3. The recommended landing distances in CRFI Table 1 are based on standard pilot techniques for the minimum distance landings from 50 ft, including a stabilized

approach at V_{Ref} using a glide slope of 3° to 50 ft or lower, a firm touchdown, minimum delay to nose lowering, minimum delay time to deployment of ground lift dump devices and application of brakes, and sustained maximum antiskid braking until stopped.

4. Landing field length is the landing distance divided by 0.6 (turbojets) or 0.7 (turboprops). If the aircraft flight manual (AFM) expresses landing performance in terms of landing distance, enter the Table from the left-hand column. However, if the AFM expresses landing performance in terms of landing field length, enter the Table from one of the right-hand columns, after first verifying which factor has been used in the AFM.

AIR

Table 2—CRFI Recommended Landing Distances (Discing/Reverse Thrust)

Reported Canadian Runway Friction Index (CRFI)														
Landing Distance (ft) Bare and Dry	0.60	0.55	0.50	0.45	0.40	0.35	0.30	0.27	0.25	0.22	0.20	0.18	Landing Field Length (ft) Bare and Dry	Landing Field Length (ft) Bare and Dry
Unfactored	Recommended Landing Distances (Discing/Reverse Thrust)												60% Factor	70% Factor
1 200	2 000	2 040	2 080	2 120	2 170	2 220	2 280	2 340	2 380	2 440	2 490	2 540	2 000	1 714
1 400	2 340	2 390	2 440	2 500	2 580	2 660	2 750	2 820	2 870	2 950	3 010	3 080	2 333	2 000
1 600	2 670	2 730	2 800	2 880	2 970	3 070	3 190	3 280	3 360	3 460	3 540	3 630	2 667	2 286
1 800	3 010	3 080	3 160	3 250	3 350	3 480	3 630	3 730	3 810	3 930	4 030	4 130	3 000	2 571
2 000	3 340	3 420	3 520	3 620	3 740	3 880	4 050	4 170	4 260	4 400	4 510	4 630	3 333	2 857
2 200	3 570	3 660	3 760	3 880	4 020	4 170	4 360	4 490	4 590	4 750	4 870	5 000	3 667	3 143
2 400	3 900	4 000	4 110	4 230	4 380	4 550	4 750	4 880	4 980	5 150	5 270	5 410	4 000	3 429
2 600	4 200	4 300	4 420	4 560	4 710	4 890	5 100	5 240	5 350	5 520	5 650	5 790	4 333	3 714
2 800	4 460	4 570	4 700	4 840	5 000	5 190	5 410	5 560	5 670	5 850	5 980	6 130	4 667	4 000
3 000	4 740	4 860	5 000	5 160	5 340	5 550	5 790	5 950	6 070	6 270	6 420	6 580	5 000	4 286
3 200	5 080	5 220	5 370	5 550	5 740	5 970	6 240	6 420	6 560	6 770	6 940	7 110	5 333	4 571
3 400	5 350	5 500	5 660	5 850	6 060	6 310	6 590	6 790	6 930	7 170	7 340	7 530	5 667	4 857
3 600	5 620	5 780	5 960	6 160	6 390	6 650	6 960	7 170	7 320	7 570	7 750	7 950	6 000	5 143
3 800	5 890	6 060	6 250	6 460	6 700	6 980	7 310	7 540	7 700	7 970	8 160	8 380	6 333	5 429
4 000	6 070	6 250	6 440	6 660	6 910	7 210	7 540	7 780	7 950	8 220	8 430	8 650	6 667	5 714

Application of the CRFI

1. The recommended landing distances in Table 2 are based on a 95 percent level of confidence. A 95 percent level of confidence means that in more than 19 landings out of 20, the stated distance in Table 2 will be conservative for properly executed landings with all systems serviceable on runway surfaces with the reported CRFI.
2. The recommended landing distances in Table 2 take into account the reduction in landing distances obtained with the use of discing and/or reverse thrust capability for a turboprop-powered aeroplane and with the use of reverse thrust for a turbojet-powered aeroplane. Table 2 is based on the landing distances recommended in Table 1 with additional calculations that give credit for discing and/or reverse thrust. Representative low values of discing and/or reverse thrust effect have been assumed, hence the data will be conservative for properly executed landings by some aeroplanes with highly effective discing and/or thrust reversing systems.
3. The recommended landing distances in CRFI Table 2 are based on standard pilot techniques for the minimum distance landings from 50 ft, including a stabilized approach at V_{Ref} using a glide slope of 3° to 50 ft or lower, a firm touchdown, minimum delay to nose lowering, minimum delay time to deployment of ground lift dump devices and application of brakes and discing and/or reverse thrust, and sustained maximum antiskid braking until stopped. In Table 2, the air distance from the screen height of 50 ft to touchdown and the delay distance from touchdown to the application of full braking remain unchanged from Table 1. The effects of discing/reverse thrust were used only to reduce the stopping distance from the application of full braking to a complete stop.
4. Landing field length is the landing distance divided by 0.6 (turbojets) or 0.7 (turboprops). If the AFM expresses landing performance in terms of landing distance, enter the Table from the left-hand column. However, if the AFM expresses landing performance in terms of landing field length, enter the Table from one of the right-hand columns, after first verifying which factor has been used in the AFM.

AIR

Table 3—Crosswind Limits for CRFI

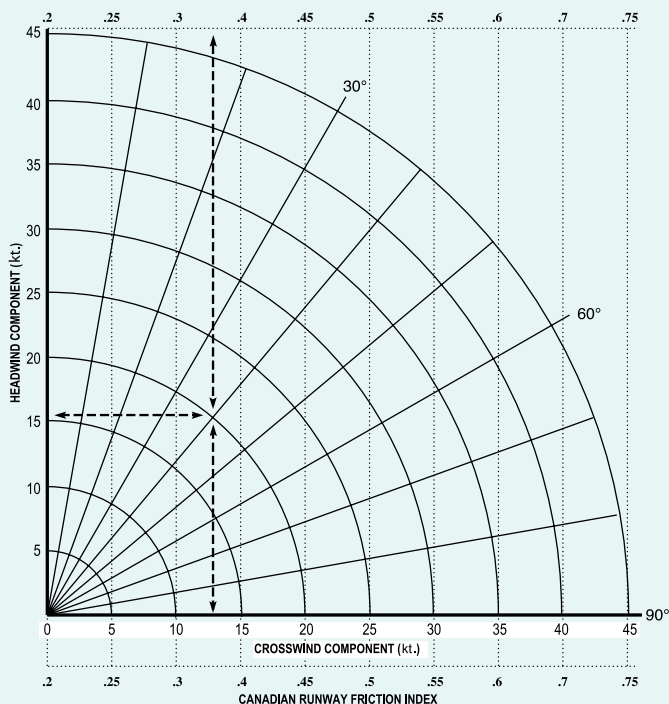

The wind is 40° off the runway heading and produces a headwind component of 15 kt and a crosswind component of 13 kt. The recommended minimum CRFI for a 13-kt crosswind component is .35. A takeoff or landing with a CRFI of .3 could result in uncontrollable drifting and yawing.

The CRFI depends on the surface type, as shown in Table 4a. It should be noted that:

- (a) the CRFI values given in Table 4a are applicable to all temperatures. Extensive measurements have shown that there is no correlation between the CRFI and the surface temperature. The case where the surface temperature is just at the melting point (i.e. about 0°C) may be an exception, as a water film may form from surface melting, which could induce slippery conditions with CRFIs less than those in Table 4a.
- (b) the CRFI may span a range of values for various reasons, such as variations in texture among surfaces within a given surface class. The expected maximum and minimum CRFIs for various surfaces are listed in Table 4b. Note that these values are based on a combination of analyses of extensive measurements and sound engineering judgment.
- (c) the largest range in CRFI is to be expected for a thin layer (3 mm or less in thickness) of dry snow on pavement (Table 4a). This variation may occur due to:
 - (i) non-uniform snow coverage; and/or
 - (ii) the tires breaking through the thin layer.

This chart provides information for calculating headwind and crosswind components. The vertical lines indicate the recommended maximum crosswind component for reported CRFI.

Example: CYOW CRFI 07/25 -4C .30 1201191200

Tower Wind 110° 20 kt.

In either case, the surface presented to the aircraft may range from snow to pavement.

Table 4a—Expected Range of CRFI by Surface Type

The range is the 95 percent confidence interval of a large set of measured data	
Dry Snow on Various Substrates	snow depth greater than 3 mm to 25 mm 0.19 — 0.37 Dry snow on packed snow
	snow depth 3 mm or less 0.12 — 0.31 Dry snow on ice
	snow depth greater than 3 mm to 25 mm 0.12 — 0.25 snow depth 3 mm or less 0.08 — 0.27 Dry snow on pavement
Snow	snow depth greater than 3 mm to 25 mm 0.21 — 0.39 snow depth 3 mm or less 0.16 — 0.76 Sanded packed snow
	0.23 — 0.47 Bare packed snow
Ice	0.12 — 0.31 Sanded ice
	0.19 — 0.35 Bare ice
	0.07 — 0.22
	← Minimum braking CRFI Maximum braking →

AIR

Table 4b—Minimum and Maximum CRFI for Various Surfaces

SURFACE	LOWER CRFI LIMIT	UPPER CRFI LIMIT
Bare Ice	No Limit	0.3
Bare Packed Snow	0.1	0.4
Sanded Ice	0.1	0.4
Sanded Packed Snow	0.1	0.5
Dry Snow on Ice (depth 3 mm or less)	No Limit	0.4
Dry Snow on Ice (depth 3 to 25 mm)	No Limit	0.4
Dry Snow on Packed Snow (depth 3 mm or less)	0.1	0.4
Dry Snow on Packed Snow (depth 3 to 25 mm)	0.1	0.4
Dry Snow on Pavement (depth 3 mm or less)	0.1	Dry Pavement
Dry Snow on Pavement (depth 3 mm to 25 mm)	0.1	Dry Pavement

1.7 JET AND PROPELLER BLAST DANGER

Jet aircraft are classified into three categories according to engine size. The danger areas are similar to those shown in Figure 1.1 and are used by ground control personnel and pilots. The danger areas have been determined for ground idle and take-off thrust settings associated with each category.

As newer aircraft are designed to handle more weight, larger engines are being used. Executive jets may have thrusts of up to 15 000 lbs; medium jets may have thrusts of up to 35 000 lbs; and some jumbo jets now have thrusts in excess of 100 000 lbs. Therefore, caution should be used when interpreting the danger areas for ground idle and take-off thrust settings, as some of

the distances shown in Figure 1.1 may need to be increased significantly. Pilots should exercise caution when operating near active runways and taxiways. With the use of intersecting runways, there is an increased possibility of jet blast or propeller wash affecting other aircraft at the aerodrome. This can occur while both aircraft are on the ground or about to take off or land. Pilots taxiing in close proximity to active runways should be careful when their jet blast or propeller wash is directed towards an active runway. Pilots operating behind a large aircraft, whether on the ground or in the take-off or landing phase, should be aware of the possibility of encountering localized high wind velocities.

Figure 1.1—JET BLAST DANGER AREAS (NOT TO SCALE)

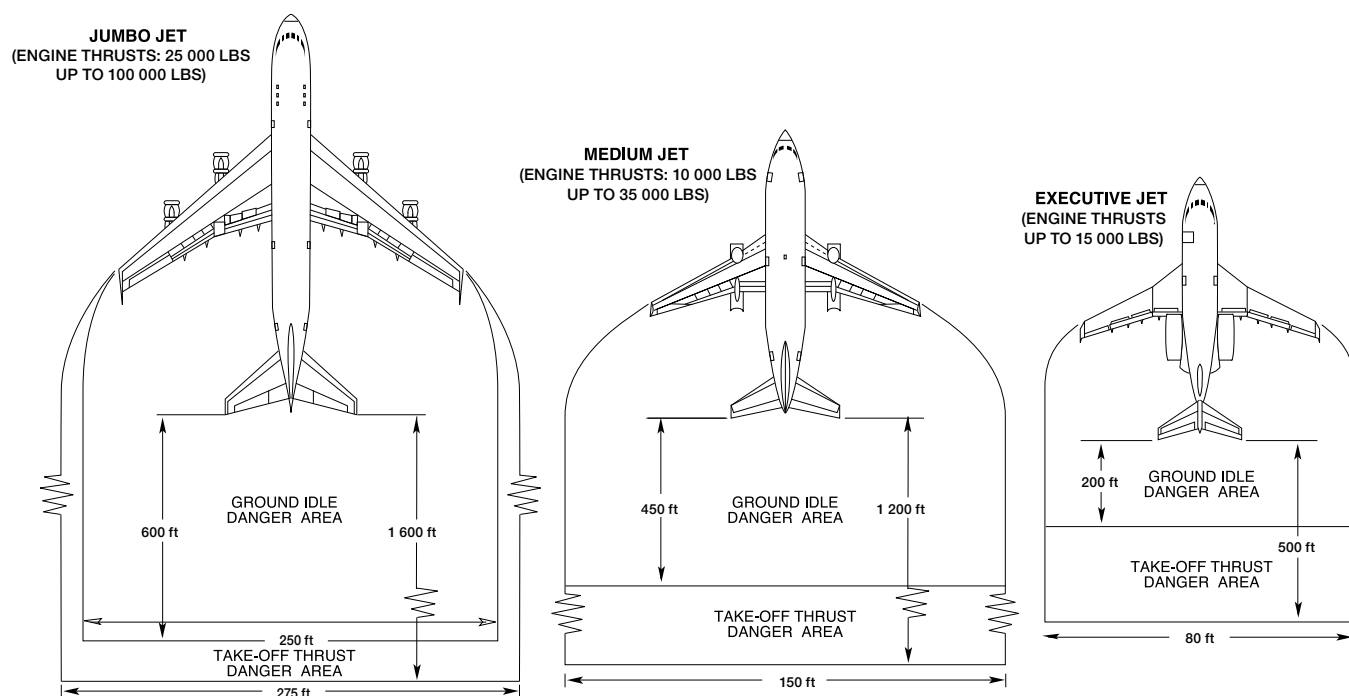

AIR

No information is available for supersonic transport aircraft or for military jet aircraft. Many of these aircraft are pure-jet aircraft with high exhaust velocities for their size, and may or may not use afterburner during the take-off phase. Thus, great caution should be used when operating near these aircraft.

Lastly, it should be noted that light aircraft with high wings and narrow-track undercarriages are more susceptible to jet blast and propeller wash related hazards than heavier aircraft with low wings and wide-track undercarriages.

The following is a Table showing the expected speed of the blast created by large turbo-prop aeroplanes:

DISTANCE BEHIND PROPELLERS	LEAVING PARKED AREA	TAXIING	TAKING OFF
ft	kt	kt	kt
60	59	45	–
80	47	36	60–70
100	47	36	50–60
120	36	28	40–50
140	36	28	35–45
180	–	–	20–30

1.8 MARSHALLING SIGNALS

Marshalling signals for the guidance of aircraft on the ground are set out in section 5 of ICAO Annex 2—*Rules of the Air*. These signals should be used in order to standardize signalling between ground and flight personnel when required for aircraft entering, departing or manoeuvring within the movement area of an aerodrome.



NOTE 1: Marshalling signals are designed for use by the marshaller, with hands illuminated as necessary to facilitate observation by the pilot, and facing the aircraft in a position:



- (a) for fixed-wing aircraft, on the left side of the aircraft, where best seen by the pilot; and
- (b) for helicopters, where the marshaller can best be seen by the pilot.



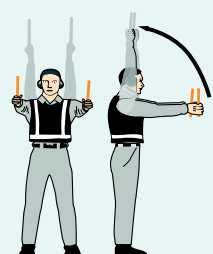

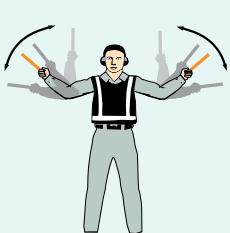
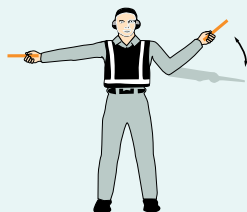
NOTE 2: The aircraft engines are numbered from left to right, with the No. 1 engine being the left outer engine. That is right to left for a marshaller facing the aircraft.

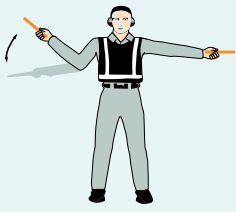
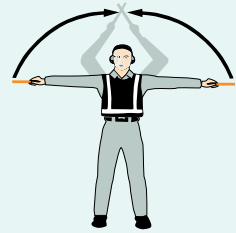
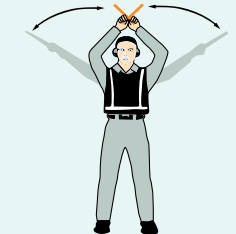
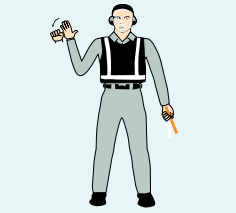
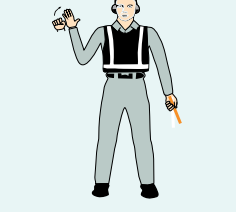





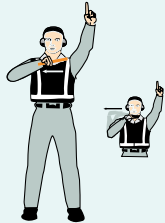
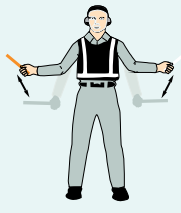
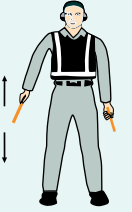

NOTE 3: Signals marked with an asterisk (*) are designed for use with hovering helicopters.

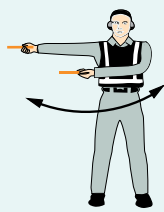

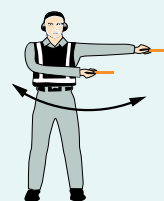
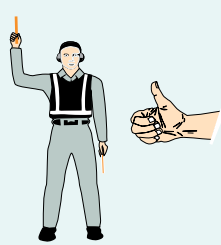
Marshalling Signals Diagram

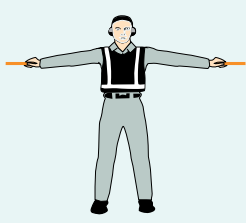
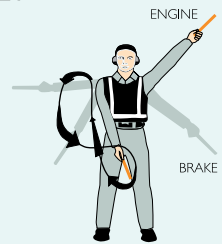
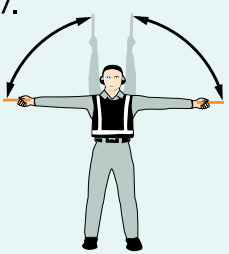
Signal	Description
1. 	Wingwalker/guide Raise right hand above head level with wand pointing up; move left-hand wand pointing down toward body. Note: This signal provides an indication by a person positioned at the aircraft wing tip, to the pilot/marshaller/push-back operator, that the aircraft movement on/off a parking position would be unobstructed.
2. 	Identify gate Raise fully extended arms straight above head with wands pointing up.
3. 	Proceed to next marshaller as directed by tower/ground control Point both arms upward; move and extend arms outward to sides of body and point with wands to direction of next marshaller or taxi area.
4. 	Straight ahead Bend extended arms at elbows and move wands up and down from chest height to head.
5. a) 	Turn left (from pilot's point of view) With right arm and wand extended at a 90-degree angle to body, make "come ahead" signal with left hand. The rate of signal motion indicates to pilot the rate of aircraft turn.

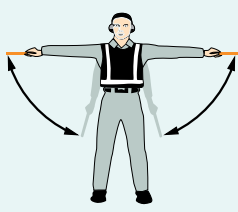
Signal	Description
5. b) 	Turn right (from pilot's point of view) With left arm and wand extended at a 90-degree angle to body, make "come ahead" signal with right hand. The rate of signal motion indicates to pilot the rate of aircraft turn.
6. a) 	Normal stop Fully extend arms and wands at a 90-degree angle to sides and slowly move to above head until wands cross.
6. b) 	Emergency stop Abruptly extend arms and wands to top of head, crossing wands.
7. a) 	Set brakes Raise hand just above shoulder height with open palm. Ensuring eye contact with flight crew, close hand into a fist. Do not move until receipt of "thumbs up" acknowledgement from flight crew.
7. b) 	Release brakes Raise hand just above shoulder height with hand closed in a fist. Ensuring eye contact with flight crew, open palm. Do not move until receipt of "thumbs up" acknowledgement from flight crew.
8. a) 	Chocks inserted With arms and wands fully extended above head, move wands inward in a "jabbing" motion until wands touch. Ensure acknowledgement is received from flight crew.

Signal	Description
8. b) 	Chocks removed With arms and wands fully extended above head, move wands outward in a "jabbing" motion. Do not remove chocks until authorized by flight crew.
9. 	Start engine(s) Raise right arm to head level with wand pointing up and start a circular motion with hand; at the same time, with left arm raised above head level, point to engine to be started.
10. 	Cut engines Extend arm with wand forward of body at shoulder level; move hand and wand to top of left shoulder and draw wand to top of right shoulder in a slicing motion across throat.
11. 	Slow down Move extended arms downwards in a "patting" gesture, moving wands up and down from waist to knees.
12. 	Slow down engine(s) on indicated side With arms down and wands toward ground, wave either right or left wand up and down indicating engine(s) on left or right side respectively should be slowed down.
13. 	Move back With arms in front of body at waist height, rotate arms in a forward motion. To stop rearward movement, use signal 6.a) or 6.b).

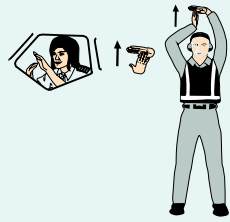
Signal	Description	Signal	Description
14. a) 	Turns while backing (for tail to starboard) Point left arm with wand down and bring right arm from overhead vertical position to horizontal forward position, repeating right-arm movement.	*19. a) 	Move horizontally left (from pilot's point of view) Extend arm horizontally at a 90-degree angle to right side of body. Move other arm in same direction in a sweeping motion.
14. b) 	Turns while backing (for tail to port) Point right arm with wand down and bring left arm from overhead vertical position to horizontal forward position, repeating left-arm movement.	*19. b) 	Move horizontally right (from pilot's point of view) Extend arm horizontally at a 90-degree angle to left side of body. Move other arm in same direction in a sweeping motion.
15. 	Affirmative/all clear Raise right arm to head level with wand pointing up or display hand with "thumbs up"; left arm remains at side by knee. <i>Note: This signal is also used as a technical/servicing communication signal.</i>	*20. 	Land Cross arms with wands downwards and in front of body.
*16. 	Hover Fully extend arms and wands at a 90-degree angle to sides.	21. 	Fire Move right-hand wand in a "fanning" motion from shoulder to knee, while at the same time pointing with left-hand wand to area of fire.
*17. 	Move upwards Fully extend arms and wands at a 90-degree angle to sides and, with palms turned up, move hands upwards. Speed of movement indicates rate of ascent.	22. 	Hold position/stand by Fully extend arms and wands downwards at a 45-degree angle to sides. Hold position until aircraft is clear for next manoeuvre.
*18. 	Move downwards Fully extend arms and wands at a 90-degree angle to sides and, with palms turned down, move hands downwards. Speed of movement indicates rate of descent.	23. 	Dispatch aircraft Perform a standard salute with right hand and/or wand to dispatch the aircraft. Maintain eye contact with flight crew until aircraft has begun to taxi.

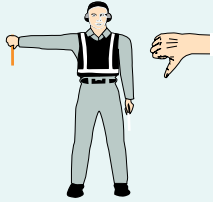
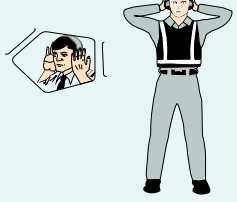
Signal	Description
24. 	Do not touch controls (technical/servicing communication signal) Extend right arm fully above head and close fist or hold wand in horizontal position; left arm remains at side by knee.
25. 	Connect ground power (technical/servicing communication signal) Hold arms fully extended above head; open left hand horizontally and move finger tips of right hand into and touch open palm of left hand (forming a "T"). At night, illuminated wands can also be used to form the "T" above head.
26. 	Disconnect power (technical/servicing communication signal) Hold arms fully extended above head with finger tips of right hand touching open horizontal palm of left hand (forming a "T"); then move right hand away from the left. Do not disconnect power until authorized by flight crew. At night, illuminated wands can also be used to form the "T" above head.
27. 	Negative (technical/servicing communication signal) Hold right arm straight out at 90 degrees from shoulder and point wand down to ground or display hand with "thumbs down"; left hand remains at side by knee.
28. 	Establish communication via interphone (technical/servicing communication signal) Extend both arms at 90 degrees from body and move hands to cup both ears.

Signal	Description
29. 	Open/close stairs (technical/servicing communication signal) With right arm at side and left arm raised above head at a 45-degree angle, move right arm in a sweeping motion towards top of left shoulder. <i>Note: This signal is intended mainly for aircraft with the set of integral stairs at the front.</i>

Marshalling signals from the pilot of an aircraft to a marshaller

Meaning of Signal	Description of Signal
Brakes engaged	Raise arm and hand, with fingers extended, horizontally in front of face, then clench fist.
Brakes released	Raise arm, with fist clenched, horizontally in front of face, then extend fingers.
Insert chocks	Arms extended, palms outwards, move hands inwards to cross in front of face.
Remove chocks	Hands crossed in front of face, palms outwards, move arms outwards.
Ready to start engine	Raise the appropriate number of fingers on one hand indicating the number of the engine to be started.

2.0 FLIGHT OPERATIONS

2.1 GENERAL

This section provides airmanship information on various flight operations subjects.

2.2 CROSSWIND LANDING LIMITATIONS

Approximately 10% of all aircraft accidents involving light aircraft in Canada are attributed to pilot failure to compensate for crosswind conditions on landing.

Light aircraft manufactured in the United States are designed to withstand, on landing, 90° crosswinds up to a velocity equal to 0.2 (20%) of their stalling speed.

This information in conjunction with the known stalling speed of a particular aircraft makes it possible to use the following crosswind component graph to derive a “general rule” for most light aircraft manufactured in the United States. The aircraft owner’s manual may give higher or limiting crosswinds. Examples follow.

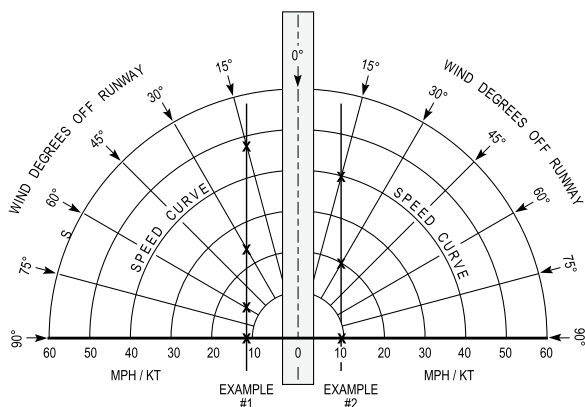

Example 1: Aircraft with a stalling speed of 60 MPH:

WIND-DEGREE	PERMISSIBLE WIND SPEEDS
90° (0.2 x 60 MPH stalling speed)	12 MPH
60° using crosswind component graph	14 MPH
30° using crosswind component graph	24 MPH
15° using crosswind component graph	48 MPH

Example 2: Aircraft with a stalling speed of 50 KT:

WIND-DEGREE	PERMISSIBLE WIND SPEEDS
90° (0.2 x 50 KT stalling speed)	10 KT
60° using crosswind component graph	12 KT
30° using crosswind component graph	20 KT
15° using crosswind component graph	40 KT

2.3 CARBURETOR ICING

Carburetor icing is a common cause of general aviation accidents. Fuel injected engines have very few induction system icing accidents, but otherwise no airplane and engine combination stands out. Most carburetor icing related engine failure happens during normal cruise. Possibly, this is a result of decreased pilot awareness that carburetor icing will occur at high power settings as well as during descents with reduced power.

In most accidents involving carburetor icing, the pilot has not fully understood the carburetor heat system of the aircraft and what occurs when it is selected. Moreover, it is difficult to understand the countermeasures unless the process of ice formation in the carburetor is understood. Detailed descriptions of this process are available in most good aviation reference publications and any AME employed on type can readily explain the carburetor heat system. The latter is especially important because of differences in systems. The pilot must learn to accept a rough-running engine for a minute or so as the heat melts and loosens the ice which is then ingested into the engine.

The following chart provides the range of temperature and relative humidity which could induce carburetor icing.

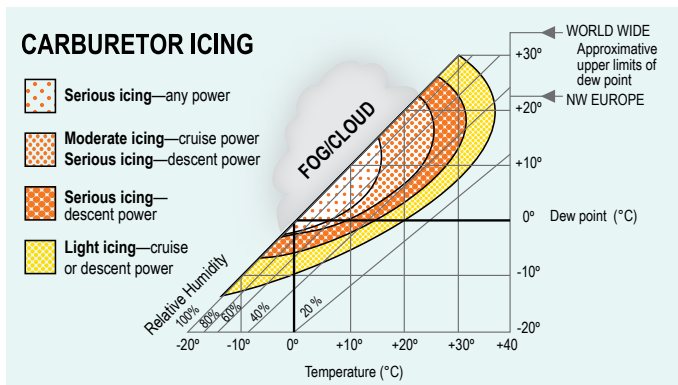

NOTE: This chart is not valid when operating on MOGAS. Due to its higher volatility, MOGAS is more susceptible to the formation of carburetor icing. In severe cases, ice may form at OATs up to 20°C higher than with AVGAS.

2.4 LOW FLYING

Before conducting any low flying, the pilot should be clear about the purpose and legality of the exercise. Accordingly, all preparations in terms of assessment of the terrain to be overflown, weather, aircraft performance, and selection of appropriate charts are important to the successful completion of the flight.

All known objects 300 feet or more AGL (or lower ones if deemed hazardous) are depicted on visual navigational charts. However, because there is only limited knowledge over the erection of man-made objects, there can be no guarantee that all such structures are known, and accordingly, an additional risk is added to the already hazardous practice of low flying.

AIR

Further, even though structures assessed as potential hazards to air navigation are required to be marked, including special high intensity strobe lighting for all structures 500 ft AGL and higher, the majority of aircraft collisions with man-made structures occur at levels below 300 ft AGL (See Obstruction Markings – AGA 6.0).

Another concern to low flying is the blasting operations associated with the logging industry. The trajectory of debris from the blasting varies with the type of explosives, substance being excavated and the canopy of trees, if any. These blasting activities may or may not be advertised by NOTAM.

2.4.1 Flying Near Power Lines

Main power lines are easy to see, but when flying in their vicinity you must take the time to look for what is really there and then use safe procedures. Remember, the human eye is limited, so if the background landscape does not provide sufficient contrast you will not see a wire or cable. Although hydro structures are big and generally quite visible, a hidden danger exists in the wires around them.

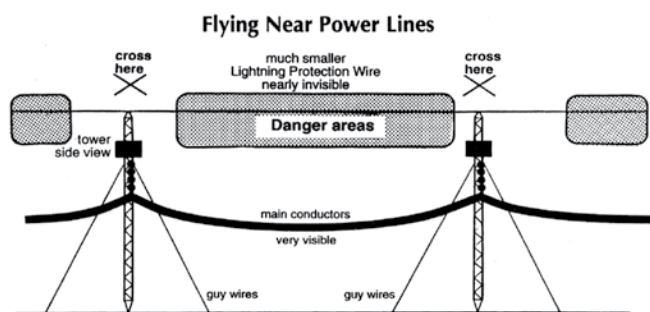

The figure shown above emphasizes this point. The main conductor cluster is made up of several heavy wires. These heavy, sagging conductors are about two inches in diameter and very visible, so they tend to distract one from seeing the guard or lightning protection wires, which are of much smaller diameter.

Guard wires do not sag the way the main conductors do and are difficult to pick out even in good visibility. The only way to be safe is to avoid the span portion of the line and **always cross at a tower**, maintaining a safe altitude, with as much clearance as possible.

- When following power lines, remain on the right-hand side relative to your direction of flight and watch for cross lines and guy cables.
- Expect radio and electrical interference in the vicinity of power lines.
- For operational low flying, do an overflight and map check first.
- Leave yourself an “out”—cross at 45 degrees to the line.
- Reduce speed in low visibility (for VFR—one mile visibility; clear of cloud; 165 kt max.).

Warning—Intentional low flying is hazardous. Transport Canada advises all pilots that low flying for weather avoidance or operational requirements is a high-risk activity.

2.4.2 Logging Operations

Extensive use is made in logging operations of equipment potentially hazardous to aircraft operations. These include highlead spars, grapple yarders and skyline cranes.

When highlead spars or grapple yarders are used, hauling and guyline cables radiate from the top of the spar or boom. Cables may cross small valleys or be anchored on side hills behind the spar. While spars generally do not exceed 130 ft AGL and are conspicuously painted, the cable system may be difficult to see. This type of equipment operates from a series of logging roads.

Figure 2.1 – Highlead Spar

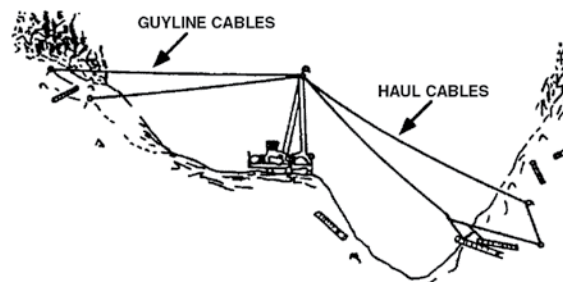

By contrast, skyline cranes consist of a single skyline cable anchored at the top and bottom of a long slope and supported by one or several intermediate poles. This cable generally follows the slope contour about 100 ft AGL, but may also cross draws and gullies and may be at heights in excess of 100 ft AGL. Skyline cables are virtually invisible from the air. Their presence is indicated by active or recently completed logging and the absence of a defined series of logging roads, although a few roads may be present.

Figure 2.2 – Skyline Crane



Pilots operating in areas where logging is prevalent must be aware when operating below 300 ft AGL that these types of equipment exist and do not always carry standard obstruction and paint markings.

2.5 FLIGHT OPERATIONS IN RAIN

An error in vision can occur when flying in rain. The presence of rain on the windscreen, in addition to causing poor visibility, introduces a refraction error. This error is because of two things: firstly, the reduced transparency of the rain-covered windscreen causes the eye to see a horizon below the true one (because of the eye response to the relative brightness of the upper bright part and the lower dark part); and secondly, the shape and pattern of the ripples formed on the windscreen, particularly on sloping ones, which cause objects to appear lower. The error may be present as a result of one or other of the two causes, or of both, in which case it is cumulative and is of the order of about 5° in angle. Therefore, a hilltop or peak 1/2 NM ahead of an aircraft could appear to be approximately 260 ft lower, (230 ft lower at 1/2 SM) than it actually is.

Pilots should remember this additional hazard when flying in conditions of low visibility in rain and should maintain sufficient altitude and take other precautions, as necessary, to allow for the presence of this error. Also, pilots should ensure proper terrain clearance during enroute flight and on final approach to landing.

2.6 FLIGHT OPERATIONS IN VOLCANIC ASH

Flight operations in volcanic ash are hazardous. Experience has shown that damage can occur to aircraft surfaces, windshields and powerplants. Aircraft heat and vent systems, as well as hydraulic and electronic systems, can also be contaminated. Powerplant failures are a common result of flight in volcanic ash, with turbine engines being particularly susceptible. Simultaneous power loss in all engines has occurred. In addition, volcanic ash is normally very heavy; accumulations of it within the wings and tail section have been encountered, with adverse effects on aircraft weight and balance.

Aviation radar is not effective in detecting volcanic ash clouds. There is no reliable information regarding volcanic ash concentrations which might be minimally acceptable for flight. Recent data suggests that “old” volcanic ash still represents a considerable hazard to safety of flight. Pilots are cautioned that ash from volcanic eruptions can rapidly reach heights in excess of FL600 and be blown downwind of the source for considerable distances. Encounters affecting aircraft performance have occurred 2 400 NM from the ash source and up to 72 hours after an eruption.

Therefore: if an ash cloud is visible to a pilot, entry into the cloud must be avoided.

The risk of entering ash in IMC or night conditions is particularly dangerous, owing to the absence of a clear visual warning.

Therefore: if PIREPs, SIGMETs (see MET 3.18), NOTAM (see MAP 5.0), and analysis of satellite imagery and/or ash cloud trajectory forecasts indicate that ash might be present within a given airspace, that airspace must be avoided until it can be determined to be safe for entry.

St. Elmo’s fire is usually a telltale sign of a night encounter, although rapid onset of engine problems may be the first indication. Pilots should exit the cloud expeditiously while following any engine handling instructions provided in the aircraft flight manuals for such circumstances.

Pilots should be aware that they may be the first line of volcanic eruptions detection in more remote areas. In the initial phase of any eruption there may be little or no information available to advise pilots of the new ash hazard. If an eruption or ash cloud is observed, an urgent PIREP (see MET 2.5 and 3.17) should be filed with the nearest ATS unit.

2.7 FLIGHT OPERATION NEAR THUNDERSTORMS

2.7.1 General

Thunderstorms are capable of containing nearly all weather hazards known to aviation. These include tornadoes, turbulence, squall line, microburst, heavy updrafts and downdrafts, icing, hail, lightning, precipitation static, heavy precipitation, low ceiling and visibility.

There is no useful correlation between the external visual appearance of a thunderstorm and the severity or amount of turbulence or hail within it. The visible thunderstorm cloud is only a portion of a turbulent system of updrafts and downdrafts that often extend far beyond. Severe turbulence may extend up to 20 NM from severe thunderstorms.

Airborne or ground based weather radar will normally reflect areas of precipitation. The frequency and severity of turbulence associated with the areas of high water content generally increases the radar return. No flight path, through an area of strong or very strong radar echoes separated by 40 NM or less, can be considered free of severe turbulence.

Turbulence beneath a thunderstorm should not be underestimated. This is especially true when the relative humidity is low. There may be nothing to see until you enter strong out-flowing winds and severe turbulence.

The probability of lightning strikes occurring to aircraft is greatest when operating at altitudes where temperatures are between -5°C and 5°C. Lightning can strike aircraft flying in clear air in the vicinity of a thunderstorm. Lightning can puncture the skin of an aircraft, damage electronic equipment, cause engine failure and induce permanent error in magnetic compasses.

Engine Water Ingestion

If the updraft velocity in the thunderstorm approaches or exceeds the terminal falling velocity of the falling raindrops, very high concentrations of water may occur. It is possible that these concentrations may exceed the quantity of water that a turbine engine is capable of ingesting. Therefore, severe thunderstorms may contain areas of high water concentration which could result in a flameout or structural failure of one or more engines. Note that lightning can also cause compressor stalls or flameouts.

PIREP

Remember, a timely PIREP will allow you and others to make the right decision earlier.

2.7.2 Considerations

- (a) Above all, never think of a thunderstorm as “light” even though the radar shows echoes of light intensity. Avoiding thunderstorms is the best policy. Remember that vivid and frequent lightning indicates a severe activity in the thunderstorm and that any thunderstorm with tops 35 000 ft or higher is severe. Whenever possible:
 - (i) don’t land or take off when a thunderstorm is approaching. The sudden wind shift of the gust front or low level turbulence could result in loss of control;
 - (ii) don’t attempt to fly under a thunderstorm even when you can see through to the other side. Turbulence under the storm could be disastrous;
 - (iii) avoid any area where thunderstorms are covering 5/8 or more of that area;
 - (iv) don’t fly into a cloud mass containing embedded thunderstorms without airborne radar;
 - (v) avoid by at least 20 NM any thunderstorm identified as severe or giving intense radar returns. This includes the anvil of a large cumulonimbus; and
 - (vi) clear the top of a known or suspected severe thunderstorm by at least 1 000 ft altitude for each 10 KT of wind speed at the cloud top.
- (b) If you cannot avoid an area of thunderstorms, consider these points:
 - (i) Tighten your seat belt and shoulder harness; secure all loose objects.
 - (ii) Plan a course that will take you through the storm area in a minimum time and hold it.
 - (iii) Avoid the most critical icing areas, by penetrating at an altitude below the freezing level or above the level of -15°C.
 - (iv) Check that pitot, carburetor or jet inlet heat are on. Icing can be rapid and may result in almost instantaneous power failure or airspeed indication loss.
 - (v) Set the power settings for turbulence penetration airspeed recommended in your aircraft manual.
 - (vi) Turn up cockpit lights to its highest intensity to minimize temporary blindness from lightning.

- (vii) When using the auto-pilot, disengage the altitude hold mode and the speed hold mode. The automatic altitude and speed controls will increase manoeuvres of the aircraft, thus increasing structural stresses.
- (viii) Tilt the airborne radar antenna up and down occasionally. This may detect hail or a growing thunderstorm cell.
- (c) If you enter a thunderstorm:
 - (i) Concentrate on your instruments; looking outside increases the danger of temporary blindness from lightning.
 - (ii) Don’t change power settings; maintain the settings for turbulence penetration airspeed.
 - (iii) Don’t attempt to keep a constant rigid altitude; let the aircraft “ride the waves”. Manoeuvres in trying to maintain constant altitude increases stress on the aircraft. If altitude cannot be maintained, inform ATC as soon as possible.
 - (iv) Don’t turn back once you have entered a thunderstorm. Maintaining heading through the storm will get you out of the storm faster than a turn. In addition, turning manoeuvres increases stress on the aircraft

2.8 LOW LEVEL WIND SHEAR

Relatively recent meteorological studies have confirmed the existence of the “burst” phenomena. These are small-scale, intense downdrafts which, on reaching the surface, spread outward from the downflow centre. This causes the presence of both vertical and horizontal wind shear that can be extremely hazardous to all types and categories of aircraft.

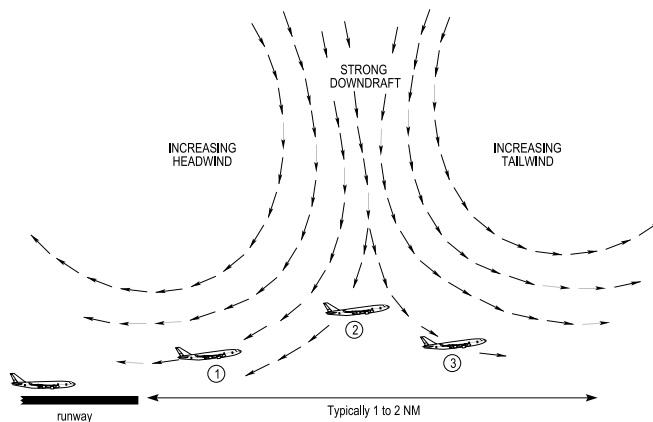

Wind shear may create a severe hazard for aircraft within 1 000 ft AGL, particularly during the approach to landing and in the takeoff phases. On takeoff, this aircraft may encounter a headwind (performance increasing) (1) followed by a downdraft (2), and tailwind (3) (both performance decreasing).

Pilots should heed wind shear PIREP as a previous pilot’s encounter with a wind shear may be the only warning. Alternate actions should be considered when a wind shear has been reported.

Characteristics of microbursts include:

- (a) *Size* - Approximately 1 NM in diameter at 2 000 ft AGL with a horizontal extent at the surface of approximately 2 to 2 1/2 NM.
- (b) *Intensity* - Vertical winds as high as 6 000 ft per minute. Horizontal winds giving as much as 45 KT at the surface (i.e., 90 KT shear).
- (c) *Types* - Microbursts are normally accompanied by heavy rain in areas where the air is very humid. However, in drier areas, falling raindrops may have sufficient time and distance to evaporate before reaching the ground. This is known as VIRGA.
- (d) *Duration* - The life-cycle of a microburst from the initial downburst to dissipation will seldom be longer than 15 minutes with maximum intensity winds lasting approximately 2 - 4 minutes. Sometimes microbursts are concentrated into a line structure and under these conditions, activity may continue for as long as an hour. Once microburst activity starts, multiple microbursts in the same general area are common and should be expected.

The best defence against wind shear is to avoid it altogether because it could be beyond your or your aircraft's capabilities. However, should you recognize a wind shear encounter, prompt action is required. In all aircraft, the recovery could require full power and a pitch attitude consistent with the maximum angle of attack for your aircraft. For more information on wind shear, consult the *Air Command Weather Manual* (TP 9352E).

Remember, should you experience a wind shear, warn others, as soon as possible, by sending a PIREP to the ground facility.

2.9 WAKE TURBULENCE

Wake turbulence is caused by wing-tip vortices and is a by-product of lift. The higher air pressure under the wings tries to move to the lower air pressure on top of the wings by flowing towards the wing tips, where it rotates and flows into the lower pressure on top of the wings. This results in a twisting rotary motion that is very pronounced at the wing tips and continues to spill over the top in a downward spiral. Therefore, the wake consists of two counter-rotating cylindrical vortices.

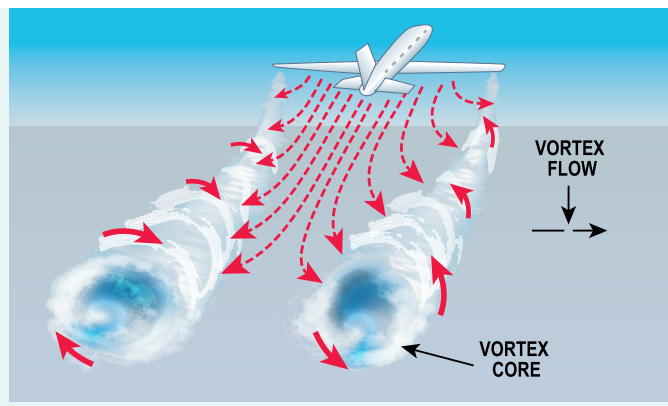

Vortex Strength

The strength of these vortices is governed by the shape of the wings, and the weight and speed of the aircraft; the most significant factor is weight. The greatest vortex strength occurs under conditions of *heavy* weight, *clean* configuration, and slow speed. The strength of the vortex shows little dissipation at altitude within 2 min of the time of initial formation. Beyond 2 min, varying degrees of dissipation occur along the vortex path; first in one vortex and then in the other. The break-up of vortices is affected by atmospheric turbulence; the greater the turbulence, the more rapid the dissipation of the vortices.

Induced Roll

Aircraft flying directly into the core of a vortex will tend to roll with the vortex. The capability of counteracting the roll depends on the wing span and control responsiveness of the aircraft. When the wing span and ailerons of a larger aircraft extend beyond the vortex, counter-roll control is usually effective, and the effect of the induced roll can be minimized. Pilots of short wing span aircraft must be especially alert to vortex situations, even though their aircraft are of the high-performance type.

Helicopter Vortices

In the case of a helicopter, similar vortices are created by the rotor blades. However, the problems created are potentially greater than those caused by a fixed-wing aircraft because the helicopter's lower operating speeds produce more concentrated wakes than fixed-wing aircraft. Departing or landing helicopters produce a pair of high-velocity trailing vortices similar to wing-tip vortices of large fixed-wing aircraft; the heavier the helicopter, the more intense the wake turbulence. Pilots of small aircraft should use caution when operating or crossing behind landing or departing helicopters.

Vortex Avoidance

Avoid the area below and behind other aircraft, especially at low altitude, where even a momentary wake turbulence encounter could be disastrous.

2.9.1 Vortex Characteristics

General

Trailing vortices have characteristics which, when known, will help a pilot visualize the wake location and thereby take avoidance precautions. Vortex generation starts with rotation (lifting off of the nosewheel) and will be severe in that airspace immediately following the point of rotation. Vortex generation ends when the nosewheel of a landing aircraft touches down.

Because of ground effect and wind, a vortex produced within about 200 feet AGL tends to be subject to lateral drift movements and may return to where it started. Below 100 feet AGL, the vortices tend to separate laterally and break up more rapidly than vortex systems at higher altitude. The vortex sink rate and levelling off process result in little operational effect between an aircraft in level flight and other aircraft separated by 1 000 feet vertically. Pilots should fly at or above a heavy jet's flight path, altering course as necessary to avoid the area

behind and below the generating aircraft. Vortices start to descend immediately after formation and descend at the rate of 400 to 500 feet per minute for large heavy aircraft and at a lesser rate for smaller aircraft, but in all cases, descending less than 1 000 feet in total in 2 minutes.

Vortices spread out at a speed of about 5 KT. Therefore, a crosswind will decrease the lateral movement of the upwind vortex and increase the movement of the downwind vortex. Thus, a light wind of 3 to 7 KT could result in the upwind vortex remaining in the touchdown zone for a period of time or hasten the drift of the downwind vortex toward another runway. Similarly, a tail wind condition can move the vortices of the preceding landing aircraft forward into the touchdown zone.

Since vortex cores can produce a roll rate of 80° per second or twice the capabilities of some light aircraft and a downdraft of 1 500 feet per minute which exceeds the rate of climb of many aircraft, the following precautions are recommended.

Pilots should be particularly alert in calm or light wind conditions where the vortices could:

- (a) remain in the touchdown area;
- (b) drift from aircraft operating on a nearby runway;
- (c) sink into takeoff or landing path from a crossing runway;
- (d) sink into the traffic pattern from other runway operations;
- (e) sink into the flight path of VFR flights at 500 feet AGL and below.

2.9.2 Considerations

On the ground

- (1) Before requesting clearance to cross a live runway, wait a few minutes when a large aircraft has just taken off or landed.
- (2) When holding near a runway, expect wake turbulence.

Takeoff

- (1) When cleared to takeoff following the departure of a large aircraft, plan to become airborne prior to the point of rotation of the preceding aircraft and stay above the departure path or request a turn to avoid the departure path.
- (2) When cleared to takeoff following the landing of a large aircraft, plan to become airborne after the point of touchdown of the landing aircraft

Enroute VFR

- (1) Avoid flight below and behind a large aircraft. If a large aircraft is observed along the same track (meeting or overtaking), adjust position laterally preferably upwind.

Landing

- (1) When cleared to land behind a departing aircraft, plan to touchdown prior to reaching the rotation point of the departing aircraft.
- (2) When behind a large aircraft landing on the same runway, stay at or above the preceding aircraft's final approach flight path, note the touchdown point and land beyond this point if it is safe to do so.
- (3) When cleared to land behind a large aircraft on a low approach or on a missed approach on the same runway, beware of vortices that could exist between the other aircraft's flight path and the runway surface.
- (4) When landing after a large aircraft on a parallel runway closer than 2 500 feet, beware of possible drifting of the vortex on to your runway. Stay at or above the large aircraft's final approach flight path, note his touchdown point and land beyond if it is safe to do so.
- (5) When landing after a large aircraft has departed from a crossing runway, note the rotation point. If it is past the intersection, continue the approach and land before the intersection. If the large aircraft rotates prior to the intersection, avoid flight below the large aircraft's flight path. Abandon the approach unless a landing is assured well before reaching the intersection.

ATC will use the words "CAUTION – WAKE TURBULENCE" to alert pilots to the possibility of wake turbulence. It is the pilots' responsibility to adjust their operations and flight path to avoid wake turbulence.

Air traffic controllers apply separation minima between aircraft. See RAC 4.1.1 for these procedures which are intended to minimize the hazards of wake turbulence.

An aircraft conducting an IFR final approach should remain on glide path as the normally supplied separation should provide an adequate wake turbulence buffer. However, arriving VFR aircraft, while aiming to land beyond the touchdown point of a preceding heavy aircraft, should be careful to remain above its flight path. If extending flight path, so as to increase the distance behind an arriving aircraft, one should avoid the tendency to develop a dragged-in final approach. Pilots should remember to apply whatever power is required to maintain altitude until reaching a normal descent path. The largest number of dangerous encounters have been reported in the last half mile of the final approach.

Be alert to adjacent large aircraft operations particularly upwind of your runway. If an intersection takeoff clearance is received, or parallel and cross runway operations are in progress, avoid subsequent heading which will result in your aircraft crossing below and behind a large aircraft.

NOTES 1: If any of the procedures are not possible and you are on the ground, WAIT! (2 minutes are usually sufficient). If on an approach, consider going around for an other approach.

2: See AIR 1.7 for Jet and Propeller Blast Danger.

2.10 CLEAR AIR TURBULENCE

These rules of thumb are given to assist pilots in avoiding clear air turbulence (CAT). They apply to westerly jet streams. The *Air Command Weather Manual* (TP 9352E) available from Transport Canada discusses this subject more thoroughly.

1. Jet streams stronger than 110 KT (at the core) have areas of significant turbulence near them in the sloping tropopause above the core, in the jet stream front below the core and on the low-pressure side of the core.
2. Wind shear and its accompanying CAT in jet streams is more intense above and to the lee of mountain ranges. For this reason, CAT should be anticipated whenever the flight path crosses a strong jet stream in the vicinity of a mountain range.
3. On charts for standard isobaric surfaces such as the 250 mbs charts, 30 KT isotachs spaced closer than 90 NM indicate sufficient horizontal shear for CAT. This area is normally on the north (low-pressure) side of the jet stream axis, but in unusual cases may occur on the south side.
4. CAT is also related to vertical shear. From the wind-aloft charts or reports, compute the vertical shear in knots-per-thousand feet. Turbulence is likely when the shear is greater than 5 KT per thousand feet. Since vertical shear is related to horizontal temperature gradient, the spacing of isotherms on an upper air chart is significant. If the 5°C isotherms are closer together than 2° of latitude (120 NM), there is usually sufficient vertical shear for turbulence.
5. Curving jet streams are more apt to have turbulent edges than straight ones, especially jet streams which curve around a deep pressure trough.
6. Wind-shift areas associated with troughs are frequently turbulent. The sharpness of the wind-shift is the important factor. Also, ridge lines may also have rough air.
7. In an area where significant CAT has been reported or is forecast, it is suggested that the pilot adjust the airspeed to the recommended turbulent air penetration speed for the aircraft upon encountering the first ripple, since the intensity of such turbulence may build up rapidly. In areas where moderate or severe CAT is expected, it is desirable to adjust the airspeed prior to encountering turbulence.

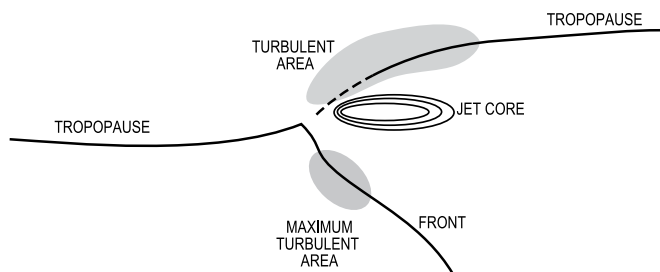

8. If jet stream turbulence is encountered with direct tailwinds or headwinds, a change of flight level or course should be initiated since these turbulent areas are elongated with the wind but are shallow and narrow. A turn to the south in the Northern Hemisphere will place the aircraft in a more favourable area. If a turn is not feasible because of airway restrictions, a climb or descent to the next flight level will usually result in smoother air.
9. When jet stream turbulence is encountered in a crosswind situation, pilots wanting to cross the CAT area more quickly should, either climb or descend based on temperature change. If temperature is rising – climb; if temperature is falling - descend. This will prevent following the sloping tropopause or frontal surface and staying in the turbulent area. If the temperature remains constant, either climb or descend.
10. If turbulence is encountered with an abrupt wind-shift associated with a sharp pressure trough, a course should be established to cross the trough rather than to fly parallel to it. A change in flight level is not as likely to reduce turbulence.
11. If turbulence is expected because of penetration of a sloping tropopause, pilots should refer to the temperature. The tropopause is where the temperature stops decreasing. Turbulence will be most pronounced in the temperature-change zone on the stratospheric side of the sloping tropopause.
12. Both vertical and horizontal wind shear are greatly intensified in mountain wave conditions. Therefore, when the flight path crosses a mountain wave, it is desirable to fly at turbulence-penetration speed and avoid flight over areas where the terrain drops abruptly. There may be no lenticular clouds associated with the mountain wave.

PIREP

Clear air turbulence can be a very serious operational factor to flight operations at all levels and especially to jet traffic flying above 15 000 feet. The best available information comes from pilots via a PIREP. Any pilot encountering CAT is urgently requested to report the time, location and intensity (light, moderate or severe as per MET 3.7) to the facility with which they are maintaining radio contact. (See MET 1.1.6.)

AIR

2.11 FLIGHT OPERATIONS ON WATER

2.11.1 General

Pilots are reminded that when aircraft are being operated on the waters of harbours, ports, lakes or other navigable waterways, they are considered to be a vessel and must abide by the provisions of CAR 602.20. (See RAC 1.10.)

The attention of all pilots and aircraft owners is drawn to the *Canada Shipping Act, 2001*, and the *Canada Marine Act*. The *Canada Marine Act* provides harbour commissions and port authorities with the authority to restrict vessel operations on the bodies of water that are in their jurisdiction

Restrictions established by the above authorities relating to vessels apply to aircraft underway or at rest on the water of a harbour, and operators are advised to furnish themselves with copies of the appropriate regulations as published by such harbour commissions or port authorities.

In addition, the *Canada Shipping Act, 2001*, through the *Vessel Operation Restriction Regulations* prohibits or imposes restrictions on the operation of vessels on certain lakes and waterways within Canada. The bodies of water affected and applicable restrictions may be found in the schedules to the *Vessel Operation Restriction Regulations* <<http://laws.justice.gc.ca/en/showtdm/cr/SOR-2008-120//?showtoc=&instrumentnumber=SOR-2008-120>>.

2.11.2 Ditching

When flying over water, a pilot must always consider the possibility of ditching. Aircraft operating handbooks usually contain instructions on ditching that are applicable to the type of aircraft. Also, the *Flight Training Manual* (TP 1102E) discusses this topic.

Before flying over water, pilots should be aware of the regulatory requirements, some of which are outlined in AIR 2.11.3.

On the high seas, it is best to ditch parallel and on top of the primary swell system, except in high wind conditions. The primary swell is usually recognized first because it is easier to see from a higher altitude while secondary systems may only be visible at a lower altitude. Wind effect may only be discernible at a much lower altitude from the appearance of the white caps. It is possible for the primary swell system to disappear from view once lower altitudes are reached as it becomes hidden by secondary systems and the wind chop.

Some guidelines can be adopted:

- (a) Never land into the face of a primary swell system unless the winds are extremely high. The best ditching heading is usually parallel to the primary swell system.

- (b) In strong winds it may be desirable to compromise by ditching more into the wind and slightly across the swell system.

Decide as early as possible that ditching is inevitable, so that power can be used to achieve the optimum impact conditions. This would permit a stabilized approach at a low rate of descent at the applicable ditching speed.

Communicate. Initially, broadcast on the last frequency in use, then switch to 121.5 as many air carriers at high altitude have a VHF radio set on 121.5. Set off the ELT if able; SARSAT has a very good chance of picking up the signal. Set your transponder to 7700. Many coastal radars will detect the signal at extremely long ranges over the water.

Surviving a ditching is one thing, but immersion and the time spent in the cold water is possibly even more hazardous. Ensure that all equipment needed for flotation and the prevention of hypothermia from a lengthy exposure to cold water is on board and available. Brief passengers on their expected actions including their responsibilities for the handling of emergency equipment, once the aircraft has stopped in the water.

2.11.3 Life-Saving Equipment For Aircraft Operating Over Water

Life jackets suiTable for each person on board are required to be carried on all aircraft taking off from and landing on water, and on all single-engine aircraft flown over water beyond gliding distance from shore. Complete requirements are contained in CARs 602.62 and 602.63.

2.11.4 Landing Seaplanes on Glassy Water

It is practically impossible to judge altitude when landing a seaplane or skiplane under certain conditions of surface and light. The following procedure should be adopted when such conditions exist.

Power assisted approaches and landings should be used although considerably more space will be required. The landing should be made as close to the shoreline as possible, and parallel to it, the height of the aircraft above the surface being judged from observation of the shoreline. Objects on the surface such as weeds and weed beds can be used for judging height. The recommended practice is to make an approach down to 200 ft (300 ft to 400 ft where visual aids for judgement of height are not available) and then place the aircraft in a slightly nose high attitude. Adjust power to maintain a minimum rate of descent, maintaining the recommended approach speed for the type until the aircraft is in contact with the surface. Do not “feel for the surface”. At the point of contact, the throttle should be eased off gently while maintaining back pressure on the control column to hold a nose high attitude which will prevent the floats from digging in as the aircraft settles into the water. Care must be taken to trim the aircraft properly to ensure that there is no slip or skid at the point of contact.

This procedure should be practised to give the pilot full confidence. It is recommended that the same procedure be used for unbroken snow conditions.

2.12 FLIGHT OPERATIONS IN WINTER

2.12.1 General

The continuing number of accidents involving all types and classes of aircraft indicates that misconceptions exist regarding the effect on performance of frost, snow or ice accumulation on aircraft.

Most commercial transport aircraft, as well as some other aircraft types, have demonstrated some capability to fly in icing conditions and have been so certified. This capacity is provided by installing de-icing or anti-icing equipment on or in critical areas of equipment, such as the leading edges of the wings and empennage, engine cowls, compressor inlets, propellers, stall warning devices, windshields and pitots. However, this equipment does not provide any means of de-icing or anti-icing the wings or empennage of an aircraft that is on the ground.

2.12.2 Aircraft Contamination on the Ground – Frost, Ice or Snow

(a) *General Information:* Where frost, ice or snow may reasonably be expected to adhere to the aircraft, the Canadian aviation regulations require that an inspection or inspections be made before takeoff or attempted takeoff. The type and minimum number of inspections is indicated by the regulations, and depends on whether or not the operator has an approved Operator's Ground Icing Operations Program using the Ground Icing Operations Standard as specified in CAR 622.11 – *Operating and Flight Rules Standards*.

The reasons for the regulations are straightforward. The degradation in aircraft performance and changes in flight characteristics when frozen contaminants are present are wide ranging and unpredictable. Contamination makes no distinction between large aircraft, small aircraft or helicopters, the performance penalties and dangers are just as real.

The significance of these effects are such that takeoff should not be attempted unless the pilot-in-command has determined, as required by the CARs, that frost ice or snow contamination is not adhering to any aircraft critical surfaces.

(b) *Critical Surfaces:* Critical surfaces of an aircraft means the wings, control surfaces, rotors, propellers, horizontal stabilizers, vertical stabilizers or any other stabilizing surface of an aircraft and, in the case of an aircraft that has rear-mounted engines, includes the upper surface of its fuselage.

Flight safety during ground operations in conditions conducive to frost, ice or snow contamination requires a knowledge of:

- (i) adverse effects of frost, ice or snow on aircraft performance and flight characteristics, which are generally reflected in the form of decreased thrust, decreased lift, increased drag, increased stall speed, trim changes, altered stall characteristics and handling qualities;
- (ii) various procedures available for aircraft ground de-icing and anti-icing, and the capabilities and limitations of these procedures in various weather conditions, including the use and effectiveness of freezing point depressant (FPD) fluids;
- (iii) holdover time, which is the estimated time that an application of an approved de-icing/anti-icing fluid is effective in preventing frost, ice, or snow from adhering to treated surfaces. Holdover time is calculated as beginning at the start of the final application of an approved de-icing/ anti-icing fluid and as expiring when the fluid is no longer effective. The fluid is no longer effective when its ability to absorb more precipitation has been exceeded. This produces a visible surface build-up of contamination. Recognition that final assurance of a safe takeoff rests in the pretakeoff inspection.

(c) *The Clean Aircraft Concept:* CARs prohibit takeoff when frost, ice or snow is adhering to any critical surface of the aircraft. This is referred to as “The Clean Aircraft Concept”.

It is imperative that takeoff not be attempted in any aircraft unless the pilot-in-command has determined that all critical components of the aircraft are free of frost, ice or snow contamination. This requirement may be met if the pilot-in-command obtains verification from properly trained and qualified personnel that the aircraft is ready for flight.

(d) *Frozen Contaminants:* Test data indicate that frost, ice or snow formations having a thickness and surface roughness similar to medium or coarse sandpaper, on the leading edge and upper surface of a wing, can reduce wing lift by as much as 30% and increase drag by 40%. Even small amounts of contaminants have caused (and continue to cause) aircraft accidents which result in substantial damage and loss of life. A significant part of the loss of lift can be attributed to leading edge contamination. The changes in lift and drag significantly increase stall speed, reduce controllability, and alter aircraft flight characteristics. Thicker or rougher frozen contaminants can have increasing effects on lift, drag, stall speed, stability and control.

More than 30 factors have been identified that can influence whether frost, ice or snow will accumulate, cause surface roughness on an aircraft and affect the anti-icing properties of freezing point depressant fluids. These factors include ambient temperature; aircraft surface temperature; the de-icing and anti-icing fluid type, temperature and

concentration; relative humidity; and wind speed and direction. Because many factors affect the accumulation of frozen contaminants on the aircraft surface, holdover times for freezing point depressant fluids should be considered as guidelines only, unless the operator's Ground Icing Operations program allows otherwise.

The type of frost, ice or snow that can accumulate on an aircraft while on the ground is a key factor in determining the type of de-icing/anti-icing procedures that should be used.

Where conditions are such that ice or snow may reasonably be expected to adhere to the aircraft, it must be removed before takeoff. Dry, powdery snow can be removed by blowing cold air or compressed nitrogen gas across the aircraft surface. In some circumstances, a shop broom could be employed to clean certain areas accessible from the ground. Heavy, wet snow or ice can be removed by placing the aircraft in a heated hangar, by using solutions of heated freezing point depressant fluids and water, by mechanical means (such as brooms or squeegees), or a combination of all three methods. Should the aircraft be placed in a heated hangar, ensure it is completely dry when moved outside; otherwise, pooled water may refreeze in critical areas or on critical surfaces.

A frost that forms overnight must be removed from the critical surfaces before takeoff. Frost can be removed by placing the aircraft in a heated hangar or by other normal de-icing procedures.

- (e) *The Cold-Soaking Phenomenon:* Where fuel tanks are located in the wings of aircraft, the temperature of the fuel greatly affects the temperature of the wing surface above and below these tanks. After a flight, the temperature of an aircraft and the fuel carried in the wing tanks may be considerably colder than the ambient temperature. An aircraft's cold-soaked wings conduct heat away from precipitation so that, depending on a number of factors, clear ice may form on some aircraft, particularly on wing areas above the fuel tanks. Such ice is difficult to see and, in many instances, cannot be detected other than by touch with the bare hand or by means of a special purpose ice detector. A layer of slush on the wing can also hide a dangerous sheet of ice beneath.

Clear ice formations could break loose at rotation or during flight, causing engine damage on some aircraft types, primarily those with rear-mounted engines. A layer of slush on the wing can also hide a dangerous sheet of ice beneath.

The formation of ice on the wing is dependent on the type, depth and liquid content of precipitation, ambient air temperature and wing surface temperature. The following factors contribute to the formation intensity and the final thickness of the clear ice layer:

- (i) low temperature of the fuel uplifted by the aircraft during a ground stop and/or the long airborne time of the previous flight, resulting in a situation that the

remaining fuel in the wing tanks is subzero. Fuel temperature drops of up to 18°C have been recorded after a flight of two hours;

- (ii) an abnormally large amount of cold fuel remaining in the wing tanks causing fuel to come in contact with the wing upper surface panels, especially in the wing root area;
- (iii) weather conditions at the ground stop, wet snow, drizzle or rain with the ambient temperature around 0°C is very critical. Heavy freezing has been reported during drizzle or rain even in a temperature range between +8° to +14°C.

As well, cold-soaking can cause frost to form on the upper and lower wing under conditions of high relative humidity. This is one type of contamination that can occur in above-freezing weather at airports where there is normally no need for de-icing equipment, or where the equipment is deactivated for the summer. This contamination typically occurs where the fuel in the wing tanks becomes cold-soaked to below-freezing temperatures because of low temperature fuel uplifted during the previous stop, or cruising at altitudes where low temperatures are encountered, or both, and a normal descent is made into a region of high humidity. In such instances, frost will form on the under and upper sides of the fuel tank region during the ground turn-around time, and tends to re-form quickly even when removed.

Frost initially forms as individual grains about 0.004 of an inch in diameter. Additional build-up comes through grain growth from 0.010 to 0.015 of an inch in diameter, grain layering, and the formation of frost needles. Available test data indicate that this roughness on the wing lower surface will have no significant effect on lift, but it may increase drag and thereby decrease climb gradient capability which results in a second segment limiting weight penalty.

Skin temperature should be increased to preclude formation of ice or frost prior to take-off. This is often possible by refuelling with warm fuel or using hot freezing point depressant fluids, or both.

In any case, ice or frost formations on upper or lower wing surfaces must be removed prior to takeoff. The exception is that takeoff may be made with frost adhering to the underside of the wings provided it is conducted in accordance with the aircraft manufacturer's instructions.

- (f) *De-icing and Anti-Icing Fluids:* Frozen contaminants are most often removed in commercial operations by using freezing point depressant fluids. There are a number of freezing point depressant fluids available for use on commercial aircraft and, to a lesser extent, on general aviation aircraft. De-icing and anti-icing fluids should not be used unless approved by the aircraft manufacturer.

Although freezing point depressant fluids are highly soluble in water, they absorb or melt ice slowly. If frost, ice or snow is adhering to an aircraft surface, the accumulation can be melted by repeated application of proper quantities

of freezing point depressant fluid. As the ice melts, the freezing point depressant mixes with the water, thereby diluting the freezing point depressant. As dilution occurs, the resulting mixture may begin to run off the aircraft. If all the ice is not melted, additional application of freezing point depressant becomes necessary until the fluid penetrates to the aircraft surface. When all the ice has melted, the remaining liquid residue is a mixture of freezing point depressant and water at an unknown concentration. The resulting film could freeze (begin to crystallize) rapidly with only a slight temperature decrease. If the freezing point of the film is found to be insufficient, the de-icing procedure must be repeated until the freezing point of the remaining film is sufficient to ensure safe operation.

The de-icing process can be sped up considerably by using the thermal energy of heated fluids and the physical energy of high-pressure spray equipment, as is the common practice.

- (g) *SAE and ISO Type I Fluids*: These fluids in the concentrated form contain a minimum of 80% glycol and are considered “unthickened” because of their relatively low viscosity. These fluids are used for de-icing or anti-icing, but provide very limited anti-icing protection.
- (h) *SAE and ISO Type II Fluids*: Fluids, such as those identified as SAE Type II and ISO Type II, will last longer in conditions of precipitation. They afford greater margins of safety if they are used in accordance with aircraft manufacturers’ recommendations.

Flight tests performed by manufacturers of transport category aircraft have shown that most SAE and ISO Type II fluids flow off lifting surfaces by rotation speeds (V_r), although some large aircraft do experience performance degradation and may require weight or other takeoff compensation. Therefore, SAE and ISO Type II fluids should be used on aircraft with rotation speeds (V_r) above 100 KT. Degradation could be significant on aeroplanes with rotation speeds below this figure.

As with any de-icing or anti-icing fluid, SAE and ISO Type II fluids should not be applied unless the aircraft manufacturer has approved their use, regardless of rotation speed. Aircraft manufacturers’ manuals may give further guidance on the acceptability of SAE and ISO Type II fluids for specific aircraft.

Some fluid residue may remain throughout the flight. The aircraft manufacturer should have determined that this residue would have little or no effect on aircraft performance or handling qualities in aerodynamically quiet areas; however, this residue should be cleaned periodically.

SAE and ISO Type II fluids contain no less than 50% glycol and have a minimum freeze point of -32°C . They are considered “thickened” because of added thickening agents that enable the fluid to be deposited in a thicker

film and to remain on the aircraft surfaces until the time of takeoff. These fluids are used for de-icing (when heated) and anti-icing. Type II fluids provide greater protection (holdover time) than do Type I fluids against frost, ice or snow formation in conditions conducive to aircraft icing on the ground.

These fluids are effective anti-icers because of their high viscosity and pseudoplastic behaviour. They are designed to remain on the wings of an aircraft during ground operations or short-term storage, thereby providing some anti-icing protection and will readily flow off the wings during takeoff. When these fluids are subjected to shear stress (such as that experienced during a takeoff run), their viscosity decreases drastically, allowing the fluids to flow off the wings and causing little adverse effect on the aircraft’s aerodynamic performance.

The pseudoplastic behaviour of SAE and ISO Type II fluids can be altered by improper de-icing/anti-icing equipment or handling. Therefore, some North American airlines have updated de-icing and anti-icing equipment, fluid storage facilities, de-icing and anti-icing procedures, quality control procedures, and training programs to accommodate these distinct characteristics. Testing indicates that SAE and ISO Type II fluids, if applied with improper equipment, may lose 20 to 60% of their anti-icing performance.

All Type II fluids are not necessarily compatible with all Type I fluids; therefore, you should refer to the fluid manufacturer or supplier for further information. As well, the use of Type II fluid over badly contaminated Type I fluid will reduce the effectiveness of the Type II fluid.

SAE and ISO Type II fluids were introduced in North America in 1985, with widespread use beginning to occur in 1990. Similar fluids, but with slight differences in characteristics, have been developed, introduced, and used in Canada.

- (i) *Type III Fluids*: Type III is a thickened freezing point depressant fluid which has properties that lie between Types I and II. Therefore, it provides a longer holdover time than Type I, but less than Type II. Its shearing and flow-off characteristics are designed for aircraft that have a shorter time to the rotation point. This should make it acceptable for some aircraft that have a V_r of less than 100 KT.

The SAE had approved a specification in AMS1428A for Type III anti-icing fluids that can be used on those aircraft with rotation speeds significantly lower than the large jet rotation speeds, which are 100 KT or greater. No fluid has yet been identified that can meet the entire Type III fluid specification. Pending publication of a Type III Holdover Time Table and availability of suitable fluids, the Union Carbide Type IV fluid in 75/25 dilution may

be used for anti-icing purposes on low rotation speed aircraft, but only in accordance with aircraft and fluid manufacturer's instructions.

- (j) *Type IV Fluids*: A significant advance is Type IV anti-icing fluid. These fluids meet the same fluid specifications as the Type II fluids and in addition have a significantly longer holdover time. In recognition of the above, Holdover Time Tables are available for Type IV.

The Product is dyed green as it is believed that the green product will provide for application of a more consistent layer of fluid to the aircraft and will reduce the likelihood that fluid will be mistaken for ice. However, as these fluids do not flow as readily as conventional Type II fluid, caution should be exercised to ensure that enough fluid is used to give uniform coverage.

Research indicates that the effectiveness of a Type IV fluid can be seriously diminished if proper procedures are not followed when applying it over Type I fluid.

All fluid users are advised to ensure that these fluids are applied evenly and thoroughly and that an adequate thickness has been applied in accordance with the manufacturer's recommendations. Particular attention should be paid to the leading edge area of the wing and horizontal stabilizer.

Further information on aircraft critical surface contamination may be found in the training packages produced by Transport Canada, *When In Doubt ... Small and Large Aircraft, and Ground Crew, Critical Surface Contamination Training* booklets and video cassettes. These priced videos and the accompanying booklets may be ordered from the CivilAviation Communications Centre:

North America only: 1-800-305-2059
 Local number: 613-993-7284
 Fax: 613-957-4208
 E-mail: *Services@tc.gc.ca*

2.12.3 Aircraft Contamination in Flight – Inflight Airframe Icing

Airframe icing can be a serious weather hazard to fixed and rotary wing aircraft in flight. Icing will result in a loss of performance in the following areas:

- (a) ice accretion on lifting surfaces will change their aerodynamic properties resulting in a reduction in lift, increase in drag and weight with a resultant increase in stalling speed and a reduction in the stalling angle of attack. Therefore, an aerodynamic stall can occur before the stall warning systems activate;
- (b) ice adhering to propellers will drastically affect their efficiency and may cause an imbalance with resultant vibration;

- (c) ice adhering to rotor blades will degrade their aerodynamic efficiency. This means that an increase in power will be required to produce an equivalent amount of lift. Therefore, during an autorotation this increase can only come from a higher than normal rate of descent. In fact, it may not be possible to maintain safe rotor RPM's during the descent and flare due to ice contamination;
- (d) ice on the windshield or canopy will reduce or block vision from the flight deck or cockpit;
- (e) carburetor icing, see AIR 2.3; and
- (f) airframe ice may detach and be ingested into jet engine intakes causing compressor stalls, loss of thrust and flame out.

2.12.3.1 Types of Ice

There are three types of ice which pilots must contend with in flight, Rime Ice, Clear Ice and Frost (see MET 2.4). For any ice to form the OAT must be at or below freezing with the presence of visible moisture.

Rime ice commonly found in stratiform clouds is granular, opaque and pebbly and adheres to the leading edges of antennas and windshields. Rime ice forms in low temperatures with a low concentration of small super-cooled droplets. It has little tendency to spread and can easily be removed by aircraft de-icing systems.

Clear ice commonly found in cumuliform clouds is glassy, smooth and hard, and tends to spread back from the area of impingement. Clear ice forms at temperatures at or just below 0°C with a high concentration of large super-cooled droplets. It is the most serious form of icing because it adheres firmly and is difficult to remove.

Frost may form on an aircraft in flight when descent is made from below-freezing conditions to a layer of warm, moist air. In these circumstances, vision may be restricted as frost forms on the windshield or canopy.

Additional references on icing include MET 2.4 and the *Air Command Weather Manual* (TP 9352E).

2.12.3.2 Aerodynamic Effects of Airborne Icing

Commercial pilots are familiar with the classic aerodynamic effects of ice accumulation on an aeroplane in flight. These can include:

- (a) reduced lift accompanied by significant increases in drag and increases in weight;
- (b) increases in stall speed and reduced stall angle of attack as ice alters the shape of an airfoil and disrupts airflow;

- (c) reduced thrust due to ice disrupting the airflow to the engine and/or degrading propeller efficiency. Ice ingested into a jet engine may induce a compressor stall and/or a flame out;
- (d) control restrictions due to water flowing back into control surfaces and freezing;
- (e) ice adhering to rotor blades will degrade their aerodynamic efficiency. This means that an increase in power will be required to produce an equivalent amount of lift. Therefore, during an autorotation this increase can only come from a higher than normal rate of descent. In fact, it may not be possible to maintain safe rotor RPM during the descent and flare due to ice contamination;
- (f) ice on the windshield or canopy will reduce or block vision from the flight deck or cockpit; and
- (g) carburetor icing (see AIR 2.3).

2.12.3.3 Roll Upset

Roll upset describes an uncommanded and possibly uncontrollable rolling moment caused by airflow separation in front of the ailerons, resulting in self-deflection of unpowered control surfaces. It is associated with flight in icing conditions in which water droplets flow back behind the protected surfaces before freezing and form ridges that cannot be removed by de-icing equipment. Roll upset has recently been associated with icing conditions involving large super-cooled droplets; however, it theoretically can also occur in conventional icing conditions when temperatures are just slightly below 0°C.

The roll upset can occur well before the normal symptoms of ice accretion are evident to the pilot, and control forces may be physically beyond the pilot's ability to overcome. Pilots may receive a warning of incipient roll upset if abnormal or sloppy aileron control forces are experienced after the autopilot is disconnected when operating in icing conditions.

Corrective Actions

If severe icing conditions are inadvertently encountered, pilots should consider the following actions to avoid a roll upset:

1. Disengage the autopilot. The autopilot may mask important clues or may self disconnect when control forces exceed limits, presenting the pilot with abrupt unusual attitudes and control forces.
2. Reduce the angle of attack by increasing speed. If turning, roll wings level.
3. If flaps are extended, do not retract them unless it can be determined that the upper surface of the wing is clear of ice. Retracting the flaps will increase the angle of attack at any given airspeed, possibly leading to the onset of roll upset.
4. Set appropriate power and monitor airspeed /angle of attack.

5. Verify that wing ice protection is functioning symmetrically by visual observation if possible. If not, follow the procedures in the aircraft flight manual.

2.12.3.4 Tail Plane Stall

As the rate at which ice accumulates on an airfoil is related to the shape of the airfoil, with thinner airfoils having a higher collection efficiency than thicker ones, ice may accumulate on the horizontal stabilizer at a higher rate than on the wings. A tail plane stall occurs when its critical angle of attack is exceeded. Because the horizontal stabilizer produces a downward force to counter the nose-down tendency caused by the centre of lift on the wing, stall of the tail plane will lead to a rapid pitch down. Application of flaps, which may reduce or increase downwash on the tail plane depending on the configuration of the empennage (i.e., low set horizontal stabilizer, mid-set, or T-tail), can aggravate or initiate the stall. Therefore, pilots should be very cautious in lowering flaps if tail plane icing is suspected. Abrupt nose-down pitching movements should also be avoided, since these increase the tail plane angle of attack and may cause a contaminated tail plane to stall.

A tail plane stall can occur at relatively high speeds, well above the normal 1G stall speed. The pitch down may occur without warning and be uncontrollable. It is more likely to occur when the flaps are selected to the landing position, after a nose-down pitching manoeuvre, during airspeed changes following flap extension, or during flight through wind gusts.

Symptoms of incipient tail plane stall may include:

- (a) abnormal elevator control forces, pulsing, oscillation, or vibration;
- (b) an abnormal nose-down trim change (may not be detected if autopilot engaged);
- (c) any other abnormal or unusual pitch anomalies (possibly leading to pilot induced oscillations);
- (d) reduction or loss of elevator effectiveness (may not be detected if the autopilot is engaged);
- (e) sudden change in elevator force (control would move down if not restrained); and/or
- (f) a sudden, uncommanded nose-down pitch.

Corrective Actions

If any of the above symptoms occur, the pilot should consider the following actions unless the aircraft flight manual dictates otherwise:

1. Plan approaches in icing conditions with minimum flap settings for the conditions. Fly the approach on speed for the configuration.

2. If symptoms occur shortly after flap extension, immediately retract the flaps to the previous setting. Increase airspeed as appropriate to the reduced setting.
3. Apply sufficient power for the configuration and conditions. Observe the manufacturer’s recommendations concerning power settings. High power settings may aggravate tail plane stall in some designs.
4. Make any nose-down pitch changes slowly, even in gusting conditions, if circumstance allow.
5. If equipped with a pneumatic de-icing system, operate several times to attempt to clear ice from the tail plane.

WARNINGS

- 1: At any flap setting, airspeed in excess of the manufacturer’s recommendations for the configuration and environmental conditions, accompanied by uncleared ice on the tail plane, may result in a tail plane stall and an uncontrollable nose-down pitch.
- 2: Improper identity of the event and application of the wrong recovery procedure will make an already critical situation even worse. This information concerning roll upset and tail plane stall is necessarily general in nature, and may not be applicable to all aircraft configurations. Pilots must consult their aircraft flight manual to determine type specific procedures for these phenomena.

2.12.3.5 Freezing Rain, Freezing Drizzle, and Large Super-Cooled Droplets

The classical mechanism producing freezing rain and/or freezing drizzle aloft involves a layer of warm air overlaying a layer of cold air. Snow falling through the warm layer melts, falls into the cold air, becomes supercooled, and freezes on contact with an aircraft flying through the cold air. Freezing rain and freezing drizzle are therefore typically found near warm fronts and trowals, both of which cause warm air to overlay cold air. Freezing rain or freezing drizzle may also occur at cold fronts, but are less common and would have a lesser horizontal extent due to the steeper slope of the frontal surface. The presence of warm air above has always provided a possible escape route to pilots who have encountered classical freezing precipitation aloft through a climb into the warm air.

Recent research has revealed that there are other non-classical mechanisms that produce freezing precipitation aloft. Flights by research aircraft have encountered freezing drizzle at temperatures down to -10° C at altitudes up to 15000 feet ASL. There was no temperature inversion—that is, no warm air aloft—present in either case. Pilots must be aware that severe icing may be encountered in conditions unrelated to warm air aloft. They must also understand that, if non-classical freezing drizzle is encountered in flight, the escape route of a climb into warmer air may not be immediately available; however, climbing remains the preferred escape route. It should allow the aircraft to reach an altitude above the formation region,

while a descent may keep the aircraft in freezing precipitation. It should be noted that, while ascending, the aircraft might get closer to the source region with smaller droplets, higher liquid water content and conventional icing.

2.12.3.6 Detecting Large Super-Cooled Droplets Conditions in Flight

Visible clues to flight crew that the aircraft is operating in large super-cooled droplets conditions will vary from type to type. Manufacturers should be consulted to assist operators in identifying the visible clues particular to the type operated. There are, however, some general clues of which pilots should be aware:

- (a) ice visible on the upper or lower surface of the wing aft of the area protected by de-icing equipment (irregular or jagged lines of ice or pieces that are self-shedding);
- (b) ice adhering to non-heated propeller spinners farther aft than normal;
- (c) granular dispersed ice crystals or total translucent or opaque coverage of the unheated portions of front or side windows. This may be accompanied by other ice patterns on the windows such as ridges. Such patterns may occur within a few seconds to one half minute after exposure to large super-cooled droplets;
- (d) unusually extensive coverage of ice, visible ice fingers or ice feathers on parts of the airframe on which ice does not normally appear; and
- (e) significant differences between airspeed or rate of climb expected and that attained at a given power setting.

Additional clues significant at temperatures near freezing:

- (a) visible rain consisting of very large droplets. In reduced visibility selection of landing or taxi lights “on” occasionally will aid detection. Rain may also be detected by the audible impact of droplets on the fuselage;
- (b) droplets splashing or splattering on the windscreen. The 40 to 50 micron droplets covered by Appendix C to Chapter 525 of the Airworthiness Manual icing criteria (Appendix C lists the certification standard for all transport category aeroplanes for flight in known icing), are so small that they cannot usually be detected; however freezing drizzle droplets can reach sizes of 0.2 to 0.5 mm and can be seen when they hit the windscreen;
- (c) water droplets or rivulets streaming on windows, either heated or unheated. Streaming droplets or rivulets are indicators of high liquid water content in any sized droplet; and/or

AIR

- (d) weather radar returns showing precipitation. Whenever the radar indicates precipitation in temperatures near freezing, pilots should be alert for other clues of large super-cooled droplets.

2.12.3.7 Flight Planning or Reporting

Pilots should take advantage of all information available to avoid or, at the very least, to plan a safe flight through known icing conditions. As well as FAs, TAFs, and METARs, pilots should ask for pertinent SIGMETs and any PIREPs received along the planned route of flight. Significant Weather Prognostic Charts should be studied, if available. Weather information should be analyzed to predict where icing is likely to be found, and to determine possible safe exit procedures should severe icing be encountered. Pilots should routinely pass detailed PIREPs whenever icing conditions are encountered.

2.12.4 Landing Wheel-Equipped Light Aircraft on Snow Covered Surfaces

During the course of each winter, a number of aircraft accidents have occurred due to pilots attempting to land wheel-equipped aircraft on surfaces covered with deep snow. This has almost invariably resulted in the aircraft nosing over.

Light aircraft should not be landed on surfaces covered with snow unless it has previously been determined that the amount of snow will not constitute a hazard.

The pamphlet *Flying with Skis* (TP 4883E), is available from your RASO.

2.12.5 Use of Seaplanes on Snow Surfaces

The operation of float-equipped aircraft or flying boats from snow covered surfaces will be permitted by Transport Canada under the following conditions:

- (a) the pilot and operator will be held responsible for confining all flights to those snow conditions found to be satisfactory as a result of previous tests or experimental flights in that type of aircraft;
- (b) passengers should not be carried; and
- (c) a thorough inspection of the float or hull bottom, all struts and fittings, all wing fittings, bracing, wing tip floats and fittings should be carried out after every flight to ensure that the aircraft is airworthy.

Seaplanes should not be landing on, or taking off from, snow surfaces except under conditions of deep firm snow, which should not be drifted or heavily crusted.

Flights should not be attempted if there is any adhesion of ice or snow to the under surface of the float or hull. When landing or forced landing a ski or float equipped aeroplane on unbroken snow surfaces, the procedure in AIR 2.11.4 is recommended.

2.12.6 Landing Seaplanes on Unbroken Snow Conditions

It has been found practically impossible to judge altitude when landing a skiplane or seaplane under certain conditions of surface and light. Under such conditions the procedures for landing seaplanes on glassy water should be used (see AIR 2.11.4).

2.12.7 Whiteout

Whiteout (also called milky weather) is defined in the *Glossary of Meteorology* (published by the American Meteorological Society) as:

“An atmospheric optical phenomenon of the polar regions in which the observer appears to be engulfed in a uniformly white glow. Neither shadows, horizon, nor clouds are discernible; sense of depth and orientation is lost; only very dark, nearby objects can be seen. Whiteout occurs over an unbroken snow cover and beneath a uniformly overcast sky, when with the aid of the snowblink effect, the light from the sky is about equal to that from the snow surface. Blowing snow may be an additional cause.”

Light carries depth perception messages to the brain in the form of colour, glare, shadows, and so on. These elements have one thing in common, namely, they are all modified by the direction of the light and changes in light intensity. For example, when shadows occur on one side of objects, we subconsciously become aware that the light is coming from the other. Thus, nature provides many visual clues to assist us in discerning objects and judging distances. What happens if these clues are removed? Let's suppose that these objects on the ground and the ground itself are all white. Add to that, a diffused light source through an overcast layer which is reflected back in all directions by the white surface so that shadows disappear. The terrain is now virtually devoid of visual clues and the eye no longer discerns the surface or terrain features.

Since the light is so diffused, it is likely that the sky and terrain will blend imperceptibly into each other, obliterating the horizon. The real hazard in whiteout is the pilot not suspecting the phenomenon because the pilot is in clear air. In numerous whiteout accidents, pilots have flown into snow-covered surfaces unaware that they have been descending and confident that they could “see” the ground.

Consequently, whenever a pilot encounters the whiteout conditions described above, or even a suspicion of them, the pilot should immediately climb if at low level, or level off and turn towards an area where sharp terrain features exist. The flight should not proceed unless the pilot is prepared and competent to traverse the whiteout area on instruments.

In addition, the following phenomena are known to cause whiteout and should be avoided if at all possible:

- (a) water-fog whiteout resulting from thin clouds of super-cooled water droplets in contact with the cold snow surface. Depending on the size and distribution of the water droplets, visibility may be minimal or nil in such conditions.
- (b) blowing snow whiteout resulting from fine snow being plucked from the surface by winds of 20 KT or more. Sunlight is reflected and diffused resulting in a nil visibility whiteout condition.
- (c) precipitation whiteout resulting from small wind-driven snow crystals falling from low clouds above which the sun is shining. Light reflection complicated by spectral reflection from the snow flakes and obscuration of land marks by falling snow can reduce visibility and depth perception to nil in such conditions.

If at all possible, pilots should avoid such conditions unless they have the suitable instruments in the aircraft and are sufficiently experienced to use a low-speed and minima rate of descent technique to land the aircraft safely.

2.13 FLIGHT OPERATIONS IN MOUNTAINOUS AREAS

The importance of proper training, procedures and pre-flight planning when flying in mountainous regions is emphasized.

In the Pacific area, the combined effect of the great mountain system and the adjacent Pacific Ocean lead to extremely changeable weather conditions and a variety of weather patterns. Some of the factors to be taken into consideration regarding the effect on aircraft performance when operating under these conditions include the following:

- (a) elevation of the airport;
- (b) temperature and pressure;
- (c) turbulence and wind effect; and
- (d) determination of safe takeoff procedures to ensure clearance over obstacles and intervening high ground.

In the western mountainous region VFR routes may be marked by diamonds on visual navigation charts. The routes are marked for convenience to assist pilots with preflight planning. The diamond marks do not imply any special level of facilities and services along the route. Pilots are cautioned that the use of the marked routes does not absolve them from proper pre-flight planning or the exercising of good airmanship practices during the proposed flight. Alternative unmarked routes are always available, the choice of a suitable route for the intended flight and conditions remains the sole responsibility of the pilot-in-command.

2.14 FLIGHT OPERATIONS IN SPARSELY SETTLED AREAS OF CANADA

“Sparsely settled area” is no longer a defined area. As such, the pilot/operator must decide what survival equipment is to be carried on board the aircraft in accordance with the regulations.

CAR 602.61, “*Survival Equipment—Flights Over Land*”, regulates the survival equipment required for aircraft operations over land in Canada. The regulation requires a pilot to carry on board the aircraft survival equipment sufficient for the survival on the ground of each person on board, taking into consideration the geographical area, the season of the year, and anticipated seasonal climatic variations. The survival equipment must be sufficient to provide the means for starting a fire, providing shelter, providing or purifying water, and visually signalling distress. The AIR Annex contains a Table that is a useful guide in helping pilots and operators choose equipment to ensure that they are operating within the regulations.

Experience has shown that pilots who are not familiar with the problems associated with navigating as well as other potential dangers of operating aircraft in sparsely settled areas of Canada tend to underestimate the difficulties involved.

Some pilots assume that operating in this area is no different than operating in the more populated areas. This leads to a lack of proper planning and preparation that can result in pilots exposing themselves, their crew, passengers and aircraft to unnecessary risks. This in turn can lead to considerable strain being placed on very limited local resources at stop-over or destination aerodromes. It has resulted in lengthy and expensive searches that could have been avoided with careful planning and preparation. Also, it has resulted in unnecessary loss of life.

Sparsely settled areas of Canada require special considerations for aircraft operations. In this area, radio aids to navigation, weather information, fuel supplies, aircraft servicing facilities, accommodation and food are usually sparse and sometimes non-existent. There are four factors to which pilots planning to operate into this area should pay particular attention.

- (a) *Flight Planning*: Plan your flight using current aeronautical charts and the latest edition of the CFS. Check NOTAM and *A.I.P. Canada (ICAO) Supplements*. Familiarize yourself with the nature of the terrain over which the flight is to be conducted. If you are not familiar with the area, consult officials of the RCMP, DND or TC at the appropriate local regional offices before departure. These officials, as well as local pilots and operators, can provide a great deal of useful advice, especially on the ever changing supply situation, the location and condition of possible emergency strips, potential hazards and en route weather conditions. In preflight planning, you must ensure that the fuel, food, accommodation and services you may require at intermediate stops and at your destination will be available.

- (b) *Weather*: Weather observation stations are scattered compared to more densely populated areas. This means that snow or rain showers, thunderstorms, strong winds, fog, cloud conditions, icing, and whiteout may exist that are unobserved and, therefore, not reported.

Experienced pilots know that whiteout can be extremely hazardous to visual flight. Whiteout can affect visibility to the extent that a pilot may have little or no visual reference by which to control his aircraft.

A thorough weather briefing before departure is a must. During the flight, use whatever communication facilities are available to obtain updated information on current weather conditions.

- (c) *Navigation*: Flights in sparsely settled areas of Canada are likely to be over longer than average legs with fewer navigation aids. Further, the route may be over terrain that is uniform in appearance with very few distinguishing features to use as reliable check points. For example, the terrain may be covered with lakes to the extent that, for the pilot who is not familiar with the area, distinguishing one lake from another is very difficult. The route may be over large tracts of unbroken forest or over tundra. In the winter, when lakes and tundra are frozen, the problem of identifying terrain features is even more acute.

Within the Northern Domestic Airspace (NDA), bearings and headings are shown on charts in degrees True (i.e., 135°T). It is strongly recommended that aircraft, engaged in day VFR flying within this airspace, be equipped with a good directional gyro and a means of checking heading using the sun or other celestial bodies as reference. To this end a manual of Tables has been prepared that greatly assists in determining the true meridian using the sun as reference. The true meridian information is then used to keep the “free” directional gyro in alignment. This manual, entitled “*Finding the Sun’s True Bearing (TP 784E)*”, is available from Transport Canada [see MAP 7.1 for the *Civil Aviation Catalogue of Publications (TP 3680E)*].

Pilots planning to fly IFR or night VFR in the NDA should review the regulations governing such flights. These are set out in CAR 602.34.

NOTE: Surface wind direction information for aerodromes located within the NDA, for purposes of takeoff and landing is reported in degrees True.

- (d) *Emergencies*: In the event of a forced landing in sparsely settled areas of Canada, survival will depend on the preparations the pilot has made for such an eventuality and knowledge of ELT Search and Rescue procedures. These procedures are detailed in the SAR Section and a list of the equipment suggested for flight in this area is found in AIR Annex. The need to carry clothing and equipment that will provide protection from insects in the summer and exposure in the other seasons cannot be overstressed.

2.14.1 Single-Engine Aircraft Operating in Northern Canada

In addition to emergency equipment required for flights in sparsely settled areas, single-engine aircraft in northern Canada should carry the equipment described below.

- (a) *Outside Arctic Archipelago*:
- (i) Telecommunications Equipment:
 - (A) HF radio (with a minimum output of 30 watts) capable of transmitting and receiving on 5680 kHz, and
 - (B) a portable emergency transmitter capable of operation on the ground independent of the aircraft battery and transmitting on a distress frequency used by DND for search and rescue.
 - (ii) Navigation Equipment:
 - (A) A gyro-stabilized magnetic compass, or
 - (B) an astro compass and a low precession gyroscopic direction indicator.

NOTES 1: If an astro compass is carried it should be accompanied with the necessary Tables and the operator should be proficient in its use.

2: Telecommunications equipment must be adequate to ensure compliance with CAR 602.146 – *Security Control of Air Traffic and Air Navigation Aids Plan (SCATANA)*.

3: Frequency 5680 kHz is for use in accordance with COM 5.14.

4: If it can be shown to the satisfaction of Transport Canada that an aircraft is otherwise satisfactorily equipped, then the requirements set forth above may be modified for flights in the area south of the Arctic Archipelago.

- (b) *Within Arctic Archipelago*: Operators proceeding to the Arctic Archipelago should meet the following additional requirements.

- (i) *Telecommunications Equipment*: VHF capable of transmitting and receiving on 121.5 and 126.7 MHz.
- (ii) *Routing*: In choosing the most suitable route, it must be remembered that under CARs, Part VII, no single-engine land plane or multi-engine land plane shall be operated on a commercial air service over water beyond gliding distance from shore except as authorized in its operator certificate, and complies with the Commercial Air Service Standards.
- (iii) *Emergency Equipment*: In addition to the equipment suggested in the Survival Advisory Information detailed in AIR Annex, it is strongly recommended that flares, a small stove or heating device and sleeping bags to accommodate all persons on board the aircraft, be carried at all times.

- (c) *Flight Itinerary or Flight Plans*: See RAC 3.6 to 3.10 inclusive.

2.15 AUTOMATIC LANDING OPERATIONS

(See COM 3.13.1 for more information.)

Some States have developed procedures wherein practice Automatic Landing Operations (autolands) may be conducted on Category I ILS facilities, or on Category II/III ILS facilities when low visibility procedures are not in force. In the case of an ILS of facility performance Category I for example, the ILS should be of Category II signal quality, without necessarily meeting the associated reliability and availability criteria for backup equipment and automatic change-over of facility performance Category II. Other procedures include verifying Category I and II facilities can, in fact, support autoland operations; compatibility of the autoland system with the aerodrome surfaces preceding the runway threshold and the runway profile; notification by the crew of their intention to conduct a practice autoland; Air Traffic Control procedures to ensure protection of the ILS signal for practice autolands; and an ATC approval once the signal protection is effected.

Until such time as Canada establishes and implements procedures to safely accommodate practice autolands on Category I/II ILS facilities or on Category III ILS facilities without the requisite low visibility procedures active, flight crews are considered solely responsible for these practice autolands. Flight crews must recognize that changes in the ILS signal quality may occur rapidly and without any warning from the ILS monitor equipment. Furthermore, flight crews are reminded to exercise extreme caution whenever ILS signals are used beyond the minima specified in the approach procedure and when conducting autolands on any category of ILS when the critical area protection is not assured by air traffic control. Pilots must be prepared to immediately disconnect the autopilot and take appropriate action should unsatisfactory Automatic Flight Control Guidance System (AFCS) performance occur during these operations.

2.16 FLIGHT OPERATIONS AT NIGHT

There are many risks associated with operating aircraft in dark-night conditions where maintaining orientation, navigation and weather avoidance may become extremely difficult. Takeoff and landing may be particularly dangerous for both VFR and IFR pilots.

A variety of illusions may result at night because of a lack of outside visual cues. Your best defense, if you do not hold an instrument rating, is to receive some instrument training, and to be aware of the illusions and their counter measures.

3.0 MEDICAL INFORMATION

3.1 GENERAL HEALTH

A healthy pilot is as essential to a safe flight as a mechanically sound aircraft. There is no precise regulation that tells pilots whether they are fit to fly and there is no pre-flight inspection to ensure fitness. Therefore, individuals must base their decision to fly on common sense, good judgement, and training prior to each flight. While flying an aircraft, a pilot must not have any condition that impairs alertness, reaction time or decision-making ability. Persons with conditions that could result in sudden or subtle incapacitation, such as epilepsy, heart disease, diabetes requiring insulin, or psychiatric illnesses, cannot be medically certified until their case is reviewed by the Civil Aviation Medicine Branch. Conditions such as anaemia, acute infections and gastrointestinal illnesses are temporarily disqualifying. When there is any doubt about their health, pilots should consult their physician or Civil Aviation Medical Examiner (CAME).

3.1.1 Mandatory Medical Reporting

Pilots are reminded that section 6.5 of the *Aeronautics Act* requires them to identify themselves as the holder of a pilot's licence prior to the commencement of any examination by a physician or optometrist. Section 6.5 further requires that the attending physician or optometrist notify the Minister of any finding that may constitute a hazard to aviation safety.

Section 6.5 also deems the pilot to have consented to the release of aviation-related findings by the physician or optometrist to the Minister.

3.2 SPECIFIC AEROMEDICAL FACTORS

3.2.1 Hypoxia

The literal definition of hypoxia is “low oxygen”. Therefore, hypoxia implies a lack of sufficient oxygen for the body to operate normally. Its onset is insidious and may be accompanied by a feeling of well being, known as euphoria. Even minor hypoxia impairs night vision and slows reaction time. More serious hypoxia interferes with reasoning, gives rise to unusual fatigue and, finally, results in a loss of consciousness. Hypoxia is classified into four different types; all are relevant to pilots and merit consideration.

(a) Hypoxic hypoxia

Hypoxic hypoxia is the result of low oxygen levels in the bloodstream. In pilots, this most often occurs with exposure to altitude (hypobaric hypoxia). At low altitudes, the partial pressure of oxygen in the atmosphere is adequate to maintain brain function at peak efficiency. Atmospheric pressure and the partial pressure of oxygen both decline at higher altitudes. At 8 000 ft ASL (2 440 m),

some people may notice a slight increase in heart rate and speed of breathing (respiratory rate). By 10 000 ft ASL (3 030 m), the partial pressure of oxygen is low enough that all pilots will experience mild hypoxia and some will become symptomatic. Pilots operating at this altitude or higher should be alert for unusual difficulty completing routine calculations and should take corrective action if difficulties are noted. To avoid hypoxia, do not fly above 10 000 ft ASL (3 050 m) without supplemental oxygen or cabin pressurization.

(b) Anaemic hypoxia

Oxygen in blood is carried by haemoglobin, which is found in red blood cells. When the red blood cell count decreases, or the haemoglobin does not function properly, less oxygen can be carried by the blood. This can occur in conditions such as heavy bleeding, some cancers, sickle cell anaemia, or carbon monoxide poisoning, to name a few. A person suffering from anaemia may notice symptoms such as breathlessness, fatigue, or chest pain, and symptoms will worsen at higher altitudes, as the effects of hypoxia and anaemia are additive.

(c) Ischaemic hypoxia/stagnant hypoxia

The term ischaemia refers to inadequate supply of blood, and ischaemic hypoxia occurs when there is inadequate blood flow to body tissues. This can occur with constriction of blood vessels (for example, this is often seen in fingers and toes exposed to cold) as well as in situations of low blood pressure and cardiac output such as fainting, or during exposure to high sustained accelerations (stagnant hypoxia). Oxygen therapy is not very helpful in this form of hypoxia. The best remedy is to correct the underlying cause.

(d) Histotoxic hypoxia

Histotoxic hypoxia refers to an inability of the cells of the body to use the oxygen available. This type of hypoxia is rare in pilots, but it can occur with certain conditions such as cyanide poisoning, chemical poisoning, and intoxication with certain drugs. Histotoxic hypoxia can also be caused by high blood alcohol levels.

3.2.2 Carbon Monoxide

Carbon monoxide is a colourless, odourless, tasteless gas that is a product of incomplete combustion. Haemoglobin, the oxygen-carrying chemical in the blood, picks up carbon monoxide over 200 times more readily than it picks up oxygen. Thus, even minute quantities in the cockpit (often from improperly vented exhaust fumes) may result in pilot incapacitation.

The symptoms of carbon monoxide poisoning are insidious. Initially, there is an inability to concentrate, thinking becomes blurred, and subsequently dizziness and headache develop. If

any of these symptoms are noticed, pilots should turn off the heater, open the air ventilators and descend to a lower altitude if it is safe to do so. If oxygen is available, it should be used. If an exhaust leak is suspected, the pilot should land the aircraft as soon as possible.

Smoking is a source of carbon monoxide. Smokers carry some carbon monoxide in their blood all the time, and may have 5 to 10 percent of their haemoglobin saturated with carbon monoxide. This reduces the oxygen-carrying capacity of the blood and smokers may become hypoxic at altitudes below 10 000 ft ASL (3 050 m).

Catalytic heaters consume oxygen and can produce carbon monoxide. For this reason they should not be used on an aircraft.

3.2.3 Hyperventilation

Hyperventilation most commonly occurs in association with anxiety, fear, or during intense concentration on a difficult task, such as performing a complicated approach procedure. Normally, the rate of breathing is controlled by the amount of carbon dioxide in the lungs and in the blood. In hyperventilation, carbon dioxide is blown off and the level of carbon dioxide in the blood drops below normal. Pilots may notice dizziness, a feeling of coldness, a sensation like a tight band around the head and pins and needles in the hands and feet, and cramping and spasms of the hands and feet. Paradoxically, they will often feel as though they cannot get enough air. Continued hyperventilation may result in a loss of consciousness. The symptoms of hyperventilation, particularly the shortness of breath, are not unlike those of hypoxia, so rather than trying to make the diagnosis, follow the procedure below:

- (a) Breathe oxygen, if available, at 100 percent. If hypoxia is the cause, the symptoms will improve markedly after three or four breaths.
- (b) If the symptoms persist, consciously slow the rate of breathing to 10–12 breaths per minute and do not breathe deeply. Breathing slowly and deeply into a paper bag is helpful, although obviously not always practical during flight. Keep the respiratory rate slow until the symptoms disappear. If below 8 000 ft ASL (2 440 m), hypoxia is unlikely to be the cause of the problem.

3.3 DECOMPRESSION SICKNESS

At ground level, the body tissues are saturated with nitrogen, the inert gas that makes up 80 percent of our atmosphere. During a rapid ascent, the rapid lowering of the external barometric pressure allows the nitrogen gas to form small bubbles (an example of this phenomenon is the bubbles formed when a bottle of pop is opened). The nitrogen bubbles form in and around blood vessels, joints and muscles, causing pain and cramps (the bends). They can also form under the skin, causing itching and tingling (the creeps), or in the lung, causing chest pain and shortness of breath (the chokes). Severe cases may

result in a loss of consciousness. The risks associated with decompression sickness increase with high rates of climb, age, obesity, physical activity and low temperatures. Flight operations above a cabin altitude of 20 000 ft ASL (6 100 m) should not be attempted unless crew members and passengers have completed specialized high-altitude indoctrination training. When decompression sickness is encountered, an immediate descent to a lower altitude is required.

3.4 SCUBA DIVING

Although normally decompression sickness does not occur below 20 000 ft ASL (6 100 m), people who fly after scuba diving may develop the symptoms at much lower altitudes. Atmospheric pressure beneath the water increases by one atmosphere for every 33 ft (10 m) of descent. Divers who breathe pressurized air for more than a few minutes supersaturate their tissues with nitrogen. For this reason, as the aircraft ascends, nitrogen bubble formation may take place, causing the bends.

After dives of less than 33 ft (1 atmosphere pressure), where decompression stops were not required, flights up to altitudes of 8 000 ft ASL (2 440 m) should be avoided for 12 hr. Where decompression stops have been required while returning to the surface, the interval should be 24 hr. For flights above 8 000 ft ASL (2 440 m), the interval is 24 hr regardless of the type of dive, as even pressurized aircraft may lose cabin pressurization.

3.5 VISION

The retina of the eye is more sensitive to hypoxia than any part of the body; one of the first symptoms of hypoxia is a decrease in night vision. For this reason, pilots flying at night are advised to use oxygen, if available, from the ground up.

Many factors affect vision. Hypoxia, carbon monoxide poisoning, alcohol, drugs, fatigue and smoking are only a few of these. After time spent in bright sunlight, the eye is slow to adapt to darkness and this may reduce night vision. To improve dark adaption, pilots should use sunglasses during the day to avoid eye fatigue. At night, cockpit lights should be kept low to maintain the dark adaption needed to see clearly outside the cockpit.

Despite modern electronics, pilots still fly in a “see-and-be seen” world. For best results, good vision is only one of the requirements. In the cockpit, it must be reinforced with good visual scan practices, especially at night. Such practices are an acquired, not an inherent, skill. In performing a visual scan, the eyes should be focused at a range that will ensure detection of traffic while there is still time to take avoiding action. This requires that pilots take an object on the horizon, focus on it and then scan all sectors of the sky, refocusing as needed to avoid “empty-field myopia” (empty-sky myopia), which can result from gazing at a featureless landscape or cloudscape. Conscientious scanning of all sections of the sky, interspersed with brief interludes of focusing on distant objects, will improve a pilot’s ability to detect distant aircraft. A clean canopy is also essential, particularly with bright sunlight. Spots on the windshield easily lead to dazzle glare and can interfere with long-range focus.

The same scan is required at night, with one difference: the part of the eye that is best suited for night vision is not in the centre. An object detected in barely adequate light will disappear if viewed directly, but will often reappear if one looks 10 to 15° to one side of the object.

Technological changes and medical experience has brought forward a proliferation in the availability and options in eye surgery directed at improving visual acuity. The Civil Aviation Medicine Branch continues to monitor this progress and has adapted the medical guidelines regarding certification for flight to reflect the growing body of knowledge and experience in this important area. The most recent information and recommendations on eye surgery can be found on the following Civil Aviation Medicine Web site: <http://www.tc.gc.ca/eng/civilaviation/opssvs/cam-eyesurgery-75.htm>.

3.6 MIDDLE-EAR AND SINUS DISCOMFORT OR PAIN

The middle ear is similar to a box: closed at one end by a flexible cover (the ear drum) and drained at the other end by a thin, straight tube (the Eustachian tube). As the aircraft climbs, air in the body cavities expands as the barometric pressure decreases. Normally, air will escape from the middle ear and the sinuses and pilots will only notice their ears “popping”. The outlet of the Eustachian tubes, however, is narrow and, if the pilot has a head cold or a throat infection, local swelling may narrow it. On ascent, air may still be able to escape, but on descent—particularly at high rates—the outlet may close like a flap, preventing air from re-entering the middle-ear cavity. The increasing ambient air pressure will then force the eardrum inward. This can lead to severe pain and decreased hearing.

Pressure in the ears can be equalized by opening and closing the mouth, swallowing, yawning, chewing gum or by holding the nostrils shut while gently blowing the nose. If the pressure in the ears (or sinuses) cannot be relieved by these manoeuvres, it is best to climb back to the original altitude or to a higher level (if this is necessary, ATC should of course be kept informed). The ears should then be cleared and a gradual descent made, clearing the ears frequently on the way down. Sometimes, the pressure in the middle ear on descent is so low relative to the external pressure that the eardrum can bleed and even rupture. This is known as barotrauma. If barotrauma occurs, a physician familiar with aeromedical conditions should be seen for treatment as soon as possible after landing.

The best advice to pilots or passengers who are suffering from head colds, sore throats or allergies is to wait until the inflammation has subsided before flying. Nasal sprays can help provide relief, but this is only temporary. A cold lasts only a few days, but a blown eardrum may take weeks to recover!

3.7 DISORIENTATION

Pilots sometimes refer to disorientation as “vertigo”, by which they mean not knowing which way is up. On the ground, spatial orientation is sensed by the combination of vision, muscle sense, and specialized organs in the inner ear that sense accelerations and position. Vision is the strongest of the orienting senses. However, in a whiteout or when flying in cloud, it is sometimes impossible to orient oneself by reference to the horizon. Under these conditions, the pilot is completely dependent upon the flight instruments and learned flying skills for control of the aircraft. Under no circumstances should the pilot rely upon his senses alone for orientation.

Although the organs of balance in the inner ear give useful information on the ground, they can give rise to dangerously false information in the air. For example, once a turn has been entered and is being maintained at a steady rate, the sensation of turning will disappear. Upon recovering from the turn, pilots may feel as though they are turning in the opposite direction and erroneously re-enter the turn, even causing the aircraft to enter into a spin. This has been responsible for many accidents. False impressions of position may also be encountered if pilots align the aircraft with a sloping cloudbank or when the horizon is distorted or apparently bent by the Northern Lights. The rule of survival when disorientated is **RELY ON YOUR FLIGHT INSTRUMENTS!**

In their training, all pilots should be exposed to disorientation by their instructors and should have had experience in recovering from unusual attitudes. Such experience will help overcome subsequent, unexpected instances of disorientation. Pilots without instrument flight training must maintain a visual horizon at all times and should never flight plan VFR into areas where bad weather or low visibility may be encountered. An instrument rating does not prevent disorientation, but the training required to obtain the rating provides the pilot with the ability to overcome it.

3.8 FATIGUE

Fatigue slows reaction time, reduces concentration and leads to errors of attention. The most common causes are insufficient rest, lack of sleep, and overexertion. Fatigue can also be aggravated by other stresses such as business pressures and financial or family problems as well as common illnesses, such as anaemia, sleep apnoea, influenza, and head colds. Pilots should be aware of the subtle effects that acute or chronic fatigue can have on motor skills and judgement, and avoid flying when either of these are present. Pilots should also practice good sleep hygiene to prevent fatigue. Pilots who find that they are often troubled by fatigue or drowsiness, even while not flying, should see their health-care provider for a thorough medical evaluation.

Boredom and fatigue aggravate each other. One method of overcoming boredom is to keep busy by making frequent ground-speed and fuel-consumption checks, and staying mentally active. Planning for diversion to alternates or studying relevant airfield charts are also helpful.

3.9 ALCOHOL

Never fly while under the influence of alcohol. It is best to allow at least 24 hr between the last drink and take-off time. Alcohol is selectively concentrated by the body into certain areas and can remain in the fluid of the inner ear even after all traces of alcohol in the blood have disappeared. This accounts for the difficulty in balance that is experienced in a hangover. Even small amounts of alcohol (0.05 percent) have been shown in simulators to reduce piloting skills. The effect of alcohol and hypoxia is additive, and at 6 000 ft ASL (1 830 m), the effect of one drink is equivalent to two drinks at sea level. The body metabolizes alcohol at a fixed rate and no amount of coffee, medication or oxygen will alter this rate. **ALCOHOL AND FLYING DO NOT MIX.**

3.10 DRUGS

Taking medicine in any form immediately before or while flying can be hazardous. Over-the-counter and herbal remedies, such as antihistamines, cough medicines, sleeping pills, and appetite suppressants, (to name just a few) may cause drowsiness, decrease mental alertness, and seriously impair the judgement and co-ordination needed by the pilot. A condition for which medicine is required may impair a pilot's proficiency, even though the symptoms are masked by medicine. Unless cleared by a Civil Aviation Medical Examiner (CAME), pilots should not fly under the influence of prescription or over-the-counter drugs or herbal remedies any more than they should fly under the influence of alcohol.

Air traffic controllers, especially those working at the centre, are particularly susceptible to sedating side effects due to their workplace environment. The need to perform repetitive tasks over prolonged periods, often in a low-light environment, makes them particularly susceptible to drowsiness. The same restrictions applied to the pilot must be observed. Additionally, since controllers are more likely to report for work while suffering from a cold than pilots are, the effects of over-the-counter cold cures must be stressed.

It should go without saying that recreational drug use has no place in aviation and illicit drug use may result in the loss or suspension of a medical certificate.

3.11 ANAESTHETICS

Questions are often asked about flying after anaesthetics. With spinal or general anaesthetics, or with serious operations, pilots should not fly until their doctor says it is safe to do so. It is difficult to generalize about local anaesthetics used in minor operations or dental work. Allergic reactions to these, if they occur, are early and by the time the anaesthetic has worn off the risk of side effects has passed. However, after extensive procedures (such as the removal of several wisdom teeth), common sense suggests waiting at least 24 hr before flying.

3.12 BLOOD DONATION

In a completely healthy individual, the fluid reduction caused by donating one unit of blood is replaced within several hours. In some people, however, the loss of blood causes disturbances to the circulation that may last for several days. While the effects at ground level are minimal, flying during this period may entail a risk. Generally, active pilots should not donate blood, but if blood has been donated they should wait at least 48 hr before flying.

3.13 IMMUNIZATIONS

After receiving routine immunizations, such as flu shots or tetanus shots, pilots should remain at the clinic for the amount of time recommended by their health-care provider. In general, this ranges from 15 to 30 min after the immunization. If the pilot feels well and there is no evidence of an adverse reaction, they may resume flying immediately without restriction. If they feel unwell or experience an adverse reaction, they should wait for 24 hr and be assessed by a health-care provider prior to flying. The Civil Aviation Medicine Branch will monitor any new immunization developments and guidelines, and recommendations will be provided as needed.

3.14 PREGNANCY

Pilots may continue to fly up to 30 weeks into their pregnancy, provided the pregnancy is normal and without complications. However, there are certain physiological changes that may affect flight safety, and the foetus may be exposed to potentially hazardous conditions. Pilots should be aware of the hazards so that they can make informed decisions on whether they choose to fly or not.

As soon as a pilot realizes that she is pregnant, she should seek prenatal care from a qualified physician or midwife and she should ensure that her maternity-care provider is aware that she is a pilot. Should problems develop with the pregnancy before the 30th week, the Regional Aviation Medical Officer (RAMO) must be notified.

In the first trimester, nausea and vomiting are common and may be worsened by turbulence, engine fumes and G forces. In the first and second trimester, there is an increased likelihood of fainting, but this is uncommon in a sitting position. However, G tolerance may be reduced. A relative anaemia may occur after the second trimester and may affect the pilot's susceptibility to hypoxia. Hypoxia is not a problem for the foetus below 10 000 ft ASL (3 050 m).

Cosmic radiation is of particular concern because of the unborn child's susceptibility to ionizing radiation. Dose equivalent is the measure of the biological harmfulness of ionizing radiation, and the present international unit of dose equivalent is the sievert (Sv). One sievert is equal to 1 000 millisieverts (mSv). The current recommendation is that the foetus should be exposed to no more than 1 mSv during the entire pregnancy, and no more than 0.5 mSv in

any given month of pregnancy. For comparative purposes, the recommended annual limit for occupational ionizing radiation exposure for an adult is 50 mSv, with a 5-year average of no more than 20 mSv per year.

Cosmic radiation is greater at the poles than at the equator and increases with altitude. On transpolar flights at 41 000 ft ASL (12 505 m), the estimated exposure is about 0.012 mSv/h, although in a solar flare this can increase by a factor of 10. The exposure at the equator is about one-half of this. A flight from Athens to New York at 41 000 ft ASL (12 505 m) would expose a pilot to approximately 0.09 mSv. A pilot flying 500 hours per year at 35 000 ft ASL (10 675 m) between 60° and 90° latitude would be exposed to 1.73 mSv annually. Although the radiation risk to the foetus is small, it does still exist. The decision to expose the foetus to this minimal degree of radiation rests with the pilot. In general, flying shorter flights at lower latitudes will decrease exposure to ionizing radiation. Further information can be obtained from the Regional Medical Office or from the FAA Advisory Circular (AC) 120-61A, dated July 6, 2006: [www.airweb.faa.gov/Regulatory_and_Guidance_Library/rgAdvisoryCircular.nsf/0/0e9f4e9ad41d6ce862571a7005a8288/\\$FILE/AC%20120-61A.pdf](http://www.airweb.faa.gov/Regulatory_and_Guidance_Library/rgAdvisoryCircular.nsf/0/0e9f4e9ad41d6ce862571a7005a8288/$FILE/AC%20120-61A.pdf).

Pilots with a normal pregnancy are considered temporarily unfit and should cease flying after the 30th week of pregnancy. The pilot may resume her flying privileges six weeks after delivery if there are no significant medical issues. A brief medical report from her attending physician should be forwarded to the RAMO. Air traffic controllers may work until the onset of labour, and may resume their duties six weeks after delivery. A medical report of fitness should be forwarded to the regional office.

3.15 POSITIVE AND NEGATIVE G

Many pilots think that unless they are performing aerobatics, knowledge about acceleration (G) is unnecessary. However, this force affects pilots in all aircraft—from the smallest ultralight to the biggest jet.

3.15.1 What is G?

G is the symbol for the rate of change of velocity and so represents both a force and a direction. The most common example is the force of gravity (g), which is 32 ft per square second. This means a body in a vacuum would fall at a speed that increases by 32 ft per second in each second of the fall. By international convention, G is described in three planes relative to the body. These are transverse (G_x), lateral (G_y), and longitudinal (G_z) (see Figure 3.1).

Convention also requires an indication of whether the force is positive (+) or negative (-). For example, acceleration from the feet to the head is positive G_z and from the head to the feet is negative G_z . The effect of acceleration on the body is due to the displacement of blood and tissues. It is important to realize that the displacement is caused by the inertia of the tissues

and this will be opposite in direction to the acceleration force. If you were fired into the air from a cannon, the acceleration would be upward, but inertia would result in a relative downward displacement of your organs and blood.

Only G_x and G_z are of practical significance to civilian pilots and the most significant result of G_x is disorientation; thus, when we speak of positive or negative G, we are referring to G_z unless otherwise noted.

3.15.2 The Effects of G

G tolerance varies greatly with the individual. Because the symptoms are caused by the displacement of blood and tissues, we would expect that a pilot with good muscle tone would have a better tolerance. This is correct. Tolerance is lowered by obesity, ill health, low blood pressure, pregnancy and many medications. It may vary from day to day in relation to fatigue, smoking, hypoxia or hangovers.

In absolute figures, G tolerance is affected by the peak value, the duration of the G force and the rate of onset. If the rate of onset is very high, positive G can result in unconsciousness, known as G-loss of consciousness (G-LOC), without any other symptoms.

The increased weight of limbs and organs interferes with movement, and forces greater than +3G make it almost impossible to escape from an aircraft in uncontrolled flight. Fine movements are less affected. Heavy equipment such as a protective helmet can cause problems with increasing G. At about +6G a pilot's head would be flexed on the chest by the increased weight of a crash helmet.

The most serious effect of positive G is the draining of blood away from the head toward the feet, causing (stagnant) hypoxia of the brain; the first symptom is vision deterioration. As G forces are experienced, the blood pressure to the retina decreases because the weight of the column of blood between the heart and the eye (and therefore the work of the heart) increases. Therefore, the retinal blood supply decreases. Vision, beginning in the periphery, starts to become dim and colourless; this is called "grey-out." As the G forces increase further, the blood flow in the back of the eye will be completely interrupted and "black-out" (temporary loss of vision) will occur, although the pilot remains conscious. There is a delay of 5–7 s between the onset of G and the visual changes because of the oxygen dissolved in the fluids of the eyeball. If G forces stabilize, there may be an improvement in the visual symptoms after 10–12 s because the body's reflexes automatically increase blood pressure.

Grey-out begins at about +2G and black-out is usually complete at +4G in the relaxed, unprotected pilot. As the G force increases, hypoxia of the brain develops and consciousness is usually lost in the unprotected pilot at over +6G (G-LOC). When the G forces decline, consciousness is quickly recovered, but there is always a brief period of confusion on awakening.

Negative G is poorly tolerated. Here, because the acceleration is from feet to head, blood pressure in the eyes and the brain is increased so "red-out" (a red haze in the vision) is experienced. Negative G in excess of -5G may cause rupture of small blood vessels in the eyes and prolonged negative G may cause brain damage. Negative G is experienced in a push-over or "bunt" and in an outside loop.

Transverse G is well tolerated; this is why astronauts recline on blastoff. Levels of up to +50 G_x can be tolerated for short intervals without tissue damage, although the acceleration interferes with breathing. In current aircraft, G_y is not a significant problem.

3.15.3 G Straining Manoeuvres

Valsalva's manoeuvre consists of bearing down against a closed glottis (the trap door between the throat and chest) while holding the nose. The same procedure, without holding the nose but with the mouth held closed, elevates the blood pressure and increases G tolerance temporarily. This manoeuvre is widely used by acrobatic pilots and may increase G tolerance by about +2G. Valsalva's manoeuvre is the original anti-G straining manoeuvre, but it is difficult to maintain.

Figure 3.1—The G Axes

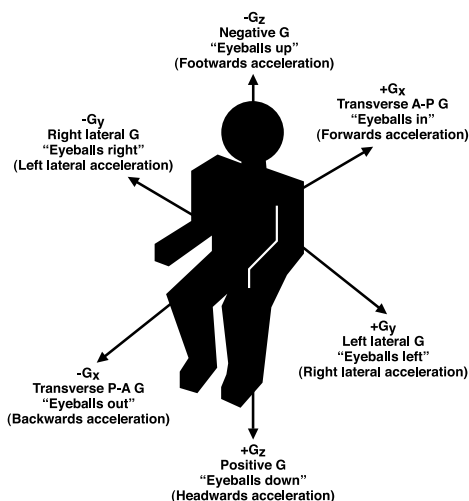

AIR

3.15.4 Dealing with G

G tolerance is affected by diet and good physical conditioning. High tolerance requires adequate hydration and normal blood sugar; hypoglycaemia (low blood sugar) markedly lowers tolerance. Tensing the muscles in the calves and thighs to reduce blood pooling and squatting down in the seat or leaning slightly forward while tensing the abdominal muscles, all reduce the distance between the heart and the brain and increase blood pressure. Physical training can be beneficial, but pilots who wish to develop high G tolerance do best with a weight-lifting program rather than intensive aerobic training. Moderate aerobic training—20–30 min daily—and running distances less than 5 km is helpful, but long-distance running decreases G tolerance by slowing the resting heart rate, which increases the chance of sudden loss of consciousness (G-LOC). A well-trained, experienced pilot can tolerate up to 9G for as long as 30 s, but there is a lot of individual variation. Acrobatic pilots who regularly fly high G manoeuvres develop high tolerance, but quickly lose it if they are no longer exposed.

4.0 MISCELLANEOUS

4.1 AIR TIME AND FLIGHT TIME

Air Time is the period of time commencing when the aircraft leaves the supporting surface and terminating when it touches the supporting surface at the next point of landing.

Flight Time is the total time from the moment an aircraft first moves under its own power for the purpose of taking off until the moment it comes to rest at the end of the flight. This should be recorded in all Pilot Log Books.

NOTE: Air Time and Flight Time should be recorded to the nearest 5 minutes, or to the nearest 6 minutes when using the decimal system as follows:

0 to 02 = .0	03 to 08 = .1	09 to 14 = .2
15 to 20 = .3	21 to 26 = .4	27 to 32 = .5
33 to 38 = .6	39 to 44 = .7	45 to 50 = .8
51 to 56 = .9	57 to 60 = 1.0	

4.2 CONDUCT OF EXPERIMENTAL TEST FLIGHTS

The C of A requires that aircraft be maintained and operated in accordance with the Aircraft Type Approval, Weight and Balance Report and Aircraft Flight Manual. If, for test demonstration or experimentation, an aircraft is to be flown outside of the approved Aircraft Flight Manual envelope, with unapproved equipment installed, with equipment intentionally disabled, or with inoperative equipment not covered by an approved Minimum Equipment List or maintenance deferral action, the C of A will be invalid. In these cases, flights may only be authorized through a Flight Permit issued by TC.

It must be emphasized that experimentation beyond the limitations imposed by the aircraft certification documentation (Type Approval, C of A, Aircraft Flight Manual, Minimum Equipment List) may be hazardous as it can reduce the safety margins designed into the aircraft and, thus, jeopardize the safety of the crew. Consequently, experimental or developmental flight testing should normally be conducted only under controlled conditions by specifically qualified aircrew after adequate engineering analysis and planning have taken place.

Before a test flight, the determinations of the conditions and limits of testing, normal and emergency procedures specific to the test, and expected aircraft handling characteristics are essential if risks are to be minimized. If companies or individuals wish to conduct a flight test program, they should apply for a Flight Permit and consult with the aircraft manufacturer and TC, who can help them to assess the risks and their capability to conduct the tests safely.

Careful planning, covering all foreseeable exigencies, is critical to safe testing.

4.3 PRACTICE SPINS

Intentional practice spins conducted at low altitudes have resulted in fatal accidents. All practice spin recoveries should be completed no less than 2 000 feet AGL, or at a height recommended by the manufacturer, whichever is the greater.

4.4 CARGO RESTRAINT

4.4.1 General

Regulations, guidelines, and references have been established to assist commercial air carriers to obtain appropriate airworthiness approval and develop suitable operational procedures to ensure adequate restraint for cargo in aircraft.

4.4.2 Regulations

Canadian Aviation Regulations (CARs) 602.86, 703.37, 704.32, and 705.39 and the associated standards, govern the requirement for proper weight and balance procedures to ensure the load is properly distributed in accordance with the C of A or flight permit.

The intent of these regulations is to ensure that the loading and restraint of cargo are such that the aircraft conforms to a configuration which is in compliance with the applicable airworthiness standards at all times. If the approved C of G or floor load limits are not adhered to the aircraft is unairworthy. Similarly, if the configuration of the restraint system does not meet the standards of the basis of certification or approval for the aircraft type, the aircraft is also unairworthy.

In this context it should be understood that the term “flight” includes all phases of operation of the aircraft including the applicable emergency landing conditions. These emergency landing conditions are defined in the various airworthiness standards and are an integral part of any basis of certification or approval.

4.4.3 Guidelines

Aircraft data is normally considered to be material provided by the aircraft manufacturer, and should include identification of hardpoints, floor loads, C of G travel and related limits. Capacity of hardpoints and floor loads takes into account the properly factored gust, manoeuvre and emergency landing loads specified in the type approval of the aircraft.

The air carrier, through his flight crew and persons responsible for loading aircraft, must ensure that the cargo, as loaded, does not cause the aircraft to be unairworthy. Examples of typical loads and capacities may be provided by the aircraft manufacturer, given the calculated strength of ropes, belts, nets and containers. Unusual loads (pipe lengths, drill rod, fuel barrels, etc.) present unique problems and are likely to require specific approval of the restraint system. Where doubt exists as to the adequacy of the proposed method of restraint,

the air carrier must submit a substantiating load and strength analysis to the Regional Manager of Airworthiness for engineering approval against the requirements of the aircraft certification or approval basis.

4.4.4 References

The air carrier is responsible to acquire and review the following Cargo Restraint Reference Material prior to submitting application to a region.

- Airworthiness Manual, Chapters 523.561
525.561
527.561
529.561
523.787
525.787
527.787
599.787
- FAA Advisory Circular 43.13-2A (a general guide useful in preparing initial application to the RMA for engineering approval. It includes critical static test load factors for FAR 23, 25, 27 and 29 aircraft)
- FAA Advisory Circular 121-27
- CAR 3.392 Cargo Compartments
- CAR 4b.359 Cargo Compartments
- FAR 23.787 Cargo Compartments
- FAR 25.787 Stowage Compartments
- FAR 27.787 Cargo and Baggage Compartments
- FAR 29.787 Cargo and Baggage Compartments
- FAR 91.203 Carriage of Cargo
- FAR 121.285 Carriage of Cargo in Passenger Compartments
- FAR 121.287 Carriage of Cargo in Cargo Compartment
- ICAO/IATA Training Manual, Book 4, Load Planners and Cargo Handlers

4.4.5 Approval

Because of the magnitude in variety, the complexity of cargo loads and the aircraft restraints involved, the following is only a generalized approval process and requires review by the Regional Managers, Aircraft Maintenance and Commercial and Business Aviation.



- (a) The carrier (applicant) reviews the preceding regulations, aircraft data and reference material, relates that to type(s) of aircraft involved and submits application to the Regional Manager, Aircraft Maintenance for engineering approval. (Application includes manufacturer’s aircraft data and type approval or certificated data, sample typical loads and proposed methods of restraint.)
- (b) Concurrently, the carrier submits an application to the Regional Manager, Air Carrier concerning operational procedures for each aircraft type involved (including training) in an amendment to the Operations Manual.
- (c) Following joint review, the Regional Manager, Aircraft Maintenance may issue engineering approval of the application and the Regional Manager, Commercial and Business Aviation may process the Operations Manual amendment. These are then both forwarded to the carrier. The air operator issues the amendment to the Operations Manual.

4.5 COLLISION AVOIDANCE – USE OF LANDING LIGHTS

Several operators have for some time been using a landing light(s) when flying at the lower altitudes and within terminal areas, both during daylight hours and at night. Pilots have confirmed that the use of the landing light(s) greatly enhances the probability of the aircraft being seen. An important side benefit for improved safety is that birds seem to see aircraft showing lights in time to take avoidance action. Therefore, it is recommended that all aircraft show a landing light(s) during the takeoff and landing phases and when flying below 2000 feet AGL within terminal areas and aerodrome traffic zones.

4.6 USE OF STROBE LIGHTS

The use of high intensity strobe lights while taxiing or awaiting takeoff holding short of the active runway can be very distracting, particularly to pilots in the final stages of approach or during the initial landing phase.

It is recommended that high intensity strobe lights not be used while the aircraft is on the ground when they adversely affect ground personnel or other pilots. Circumstances permitting, high intensity strobe lights should be activated anytime the aircraft is occupying an active runway, including awaiting takeoff clearance while holding on the active runway. They should be extinguished after landing once clear of the active runway.

High intensity strobe lights should not be used inflight when there is an adverse reflection from clouds or other weather phenomena.

4.7 MANNED FREE BALLOON OPERATIONS

Pilots and owners of balloons, like all other aircraft pilots and owners, must comply with the CARs with respect to crew licensing, aircraft registration and operating procedures.

4.7.1 Balloon Operations with Fare-Paying Passengers

CAR 603.17 states, “No person shall operate a balloon under this Division unless the person complies with the provisions of a special flight operations certificate - balloons issued by the Minister pursuant to Section 603.18.”

To qualify for a special flight operations certificate to permit the operation of balloons with fare-paying passengers, operators must:

- (a) maintain balloons in accordance with the requirements of CAR 605;
- (b) ensure that the balloons are properly equipped for the area and type of operation; and
- (c) employ flight crew members who meet the requirements of CAR 623.21, namely, who:
 - (i) are at least eighteen years of age,
 - (ii) hold a Balloon Pilot Licence issued by Transport Canada,
 - (iii) hold a Medical Certificate, Category 1 or 3,
 - (iv) have accumulated a minimum of 50 hours flight-time in untethered balloons or are the holder of a Canadian Balloon Licence with a valid Flight Instructor Rating - Balloon Category, and
 - (v) demonstrate annually a satisfactory level of knowledge and ability to perform normal and emergency operating procedures on the specific AX class of balloon to be operated.

4.8 PARACHUTE JUMPING/SKYDIVING

Parachuting or skydiving is a high-risk activity that can result in death or serious injury. As such, any individual participating in this activity must take full responsibility for their personal safety.

Transport Canada **does not** regulate the sport of parachuting directly. Transport Canada **does not** regulate or have licensing or certification requirements for parachute equipment, parachute packers/riggers, parachuting instructors or coaches.

It is strongly recommended that persons participating in parachuting activities be conversant with the procedures and standards established by associations representing parachuting activities. In Canada, that association is:

Canadian Sport Parachuting Association (CSPA)
 300 Forced Road
 Russell ON K4R 1A1
 Tel.: 613-445-1881

Transport Canada regulations pertaining to parachuting are in place to ensure the safety and efficiency of the air navigation system in which parachuting takes place and to ensure the safety of persons and property on the ground.

CAR 602.26 states, “Except where permitted in accordance with section 603.37, no pilot-in-command of an aircraft shall permit, and no person shall conduct, a parachute descent from the aircraft

- (a) in or into controlled airspace or an air route; or
- (b) over or into a built-up area or an open-air assembly of persons.”

CAR 603.37 states, “...a pilot-in-command may permit and a person may conduct a parachute descent under this Division if the person complies with the provisions of a special flight operations certificate - parachuting issued by the Minister pursuant to Section 603.38.”

4.9 HANG GLIDER AND PARAGLIDER OPERATIONS

Hang gliders and paragliders are not required to be registered or to bear identification marks. There are no airworthiness standards or requirements imposed by the CARs. The CARs do not impose any training requirements for hang glider or paraglider pilots, and the regulations do not require these pilots to hold any pilot licence or permit to operate their aircraft. There is, however, a requirement to successfully complete a written examination before piloting hang gliders and paragliders in controlled airspace. Section 602.29 of the CARs outlines airspace requirements for hang gliders and paragliders. Hang glider operators may use an ultralight aeroplane to tow a hang glider. Before doing so, these operators are required to notify Transport Canada.

The Hang Gliding and Paragliding Association of Canada (HPAC) has developed standards for pilot ratings, competitions, setting records, safety procedures and reporting, as well as for solo and two-place pilot instruction. Information regarding HPAC operations and procedures may be obtained from:

Margit Nance
 Executive Director
 Hang Gliding and Paragliding Association of Canada (HPAC)
 308-1978 Vine St.
 Vancouver BC V6K 4S1

E-mail:..... admin@hpac.ca
 Tel.:..... 877-370-2078

4.10 ULTRALIGHT AEROPLANE

Pilots interested in flying ultralight aeroplanes or advanced ultralight aeroplanes are encouraged to contact their Transport Canada regional office for information on regulation and licence requirements. See GEN 1.1.1 for addresses and telephone numbers.

Pending amendment of the CARs, the *Ultra-light Aeroplane Transition Strategy* outlines requirements for the operation of ultralight aeroplanes in Canada. This document can be obtained from Transport Canada offices or viewed online at: www.tc.gc.ca/eng/civilaviation/standards/general-recavi-ultralight-menu-2457.htm.

A copy of the *Study and Reference Guide—Pilot Permit—Ultralight Aeroplane* (TP 14453E) is available at: www.tc.gc.ca/eng/civilaviation/publications/menu.htm.

4.11 CIRCUIT BREAKERS AND ALERTING DEVICES

Automatic protective devices (circuit breakers) are provided within aircraft systems to minimize distress to the electrical system and hazard to the aircraft in the event of wiring faults or serious malfunction of a system or connected equipment. Alerting devices provide the pilot with a visual and/or aural alarm to direct the pilot’s attention to a situation that may require an immediate intervention by the pilot.

Good operating practices suggest a popped circuit breaker can indicate that there is a potential problem being protected. The practice of attempting one reset should only be considered if the equipment rendered unusable is considered essential for the continued safety of the flight. Depending on the amperage of the circuit breaker and its location within the circuit being protected, resetting a popped circuit breaker may create a more adverse situation than simply leaving the circuit breaker out. Indiscriminately resetting popped circuit breakers should be avoided.

Crew members are cautioned against pulling circuit breakers on board an aircraft in order to silence an alerting or warning device that may in fact be providing a valid warning or alarm. Examples of such alarms include landing gear warning horn with certain flap/slat combinations, overspeed warnings, ground proximity warning system alerts and washroom smoke detectors. Deactivating the alerting or warning device by pulling circuit breakers compromises or may compromise the safety of flight. Exceptions would be acceptable for an obvious malfunction resulting in continuous erroneous warnings. In these cases, a defect entry in the aircraft journey log book must be made.

4.12 DESIGN EYE REFERENCE POINT

Some aircraft manufacturers provide reference points which the pilot uses while making the seat adjustments. These reference points could be something as simple as two balls affixed to the glare shield which the pilot must line up visually. In a two-pilot aircraft the reference points could be formed by three balls in a triangle and each pilot would adjust the seat until the respective reference balls line up. The intent, of course, is to have the pilot adjust the seat in order for the eyes of the pilot to be at the optimum location for visibility, inside and outside the cockpit, as well as the correct position for access to the cockpit switches and knobs. The engineering that results in the manufacturer placing these balls on the glare shield is called ERGONOMICS. This optimum position for the pilot's eyes is referred to as the Design Eye Reference Point.

If there is no information on the design eye reference point in the aircraft operating manual, then it is suggested that the pilot could write the manufacturer and request the information. Failing that, the following guidelines should be considered when attempting to locate the correct seat placement (height, as well as fore and aft placement):

- (a) all flight controls must be free of restriction throughout the full travel of the controls;
- (b) flight instruments and warning lights must be visible to the pilot without being obscured by items such as the top of the glare shield;
- (c) forward out-of-the-cockpit visibility should be sufficient to ensure that things such as the nose of the aircraft do not block the view of the pilot, especially during a normal approach and landing; and
- (d) the chosen seat position should be comfortable for the pilot.

4.13 FIRST AID KITS ON PRIVATELY OWNED AND OPERATED AIRCRAFT

CAR 602.60 requires a first aid kit to be carried on board every power-driven aircraft, other than an ultra-light aeroplane. The CARs include the first aid kit contents for all operators except those aircraft that are privately owned and operated. Therefore, the following is a list of the recommended items that should be carried in a first aid kit on board aircraft that are privately owned and operated:

ITEM	SUPPLIES AND EQUIPMENT	QUANTITY FOR FIRST AID KIT
1.	Antiseptic - wound solution, 60 mL or antiseptic swabs (10 pack)	1
2.	Applicator - disposable (10 pack) (not needed if antiseptic swabs used)	1
3.	Bandage - adhesive strips	25
4.	Bandage - gauze 7.5 cm x 4.5 m	2
5.	Bandage - triangular 100 cm folded and 2 safety pins	2
6.	Container - First Aid Kit	1
7.	Dressing - burn 10 cm x 10 cm	4
8.	Dressing - compress, sterile 7.5 cm x 12 cm approx.	2
9.	Dressing - gauze, sterile 7.5 cm x 7.5 cm approx.	4
10.	Hand Cleanser or cleansing towellettes, 1 package	1
11.	Manual - First Aid, current edition	1
12.	Pad with shield or tape for eye	1
13.	Record - First Aid (section 10.7)	1
14.	Scissors - 10 cm	1
15.	Splint set with padding - assorted sizes	1
16.	Tape - Adhesive, surgical 1.2 cm x 4.6 m	1
17.	Tweezers - splinter	1
18.	Latex Gloves	1 pair

AIR ANNEX

1.0 SURVIVAL ADVISORY INFORMATION

A basic survival manual should be carried, appropriate to the area of flight.

Private pilots should obtain some training in certain aspects of survival if they have never spent time in the bush in winter or summer. Those planning to fly above the tree line should obtain more specialized training.

Locating and saving people in aeronautical emergencies has been greatly improved by the changes implemented by the SARSAT/COSPAS members. Today the SARSAT/ COSPAS system provides global detection capability by satellite. The improvements in reliability of ELTs in conjunction with the global application SARSAT/COSPAS systems has greatly increased the chances of early detection and location of crash survivors. The carriage of food is no longer a critical item in survival and is left as a personal choice of the individual operator.

Rule: Provide Shelter: must keep dry and out of wind to prevent death from hypothermia.		
Geographic Area	Season	Equipment and other items
West Coast, British Columbia	All seasons	Survival Equipment Suggestions: To provide protection from rain, sleet and sometimes snow; plus wind; and insulation from wet ground. Reason: Hypothermia possible in all seasons if person becomes wet and unable to get out of the wind. 1. tent 2. tarpaulin 8' x 8' (could be nylon sheet) – ideally blaze orange colour 3. saw to make shelter from branches, but difficult in wet conditions to make shelter rain proof 4. personal rain protection – could be as simple as a garbage bag 5. space blankets (not to be used on sleeping bags – sweating will soak you in two hours) Use as tarpaulin or for short periods to warm up a person by wrapping around them. 6. Air inflated mattress or unicell foam pad 7. Branches piled 8" deep and dry; (needs evergreen trees and saw or axe plus experience) [(6 and 7 are for shelter from ground; cold ground sucks heat out of body) able to get out of wind] 8. Sewing Kit to repair clothing, etc.
	Spring and Summer	9. To the above, add mosquito head nets and possibly tape for taping jacket wrists and pant bottoms for protection from insects.
Interior British Columbia – mountain country	Winter	Greatest protection required from wind and lower temperatures. As for coast, plus sleeping bag (one for each 2 persons). Sleeping bags must be dried out each day or they become useless after 2 days. In a survival situation never have everyone asleep at the same time. Most deaths from hypothermia occur well above the freezing temperature.
Prairies below timberline	All seasons	As above for BC Interior. Minimal protection needed during summer temperature is normally high. Consider in fall and winter, lots of protection from rain, snow, etc. There is still a problem in these seasons from hypothermia.
Ontario to East Coast below timberline	All seasons except higher humidities can be expected	As above for BC Interior. Protect from wind in all seasons and any form of wetness.
Newfoundland	All seasons	As above for BC Interior. Protection from wind and sea breeze which can be devastating.
North of tree line	Summer	As above for BC Interior. Wind and insect protection are most important. Days are long. Lots of time to set up shelter.
	Winter	Sleeping bag with wind protection paramount. Usually no fuel for wood fire to provide warmth.



Rule: Means of making fire.		
Geographic Area	Season	Equipment and other items
West Coast, British Columbia	All seasons	Making a fire on the West Coast of B.C. is very difficult on wet rainy days and especially in winter when cold weather cools fuel.
Remaining wooded areas of Canada	All seasons	As above except that starting and keeping fire going using trees branches shrubs, etc., is much easier.
Above treeline	All seasons	Need fuel tablets for heat and cooking if there is something to cook.
Applicable to all	All seasons	Suggested equipment: 1. waterproof matches , e.g., matches in a waterproof container. 2. candle for starting stubborn fire. 3. fuel tablets 4. saw, axe (if knowledgeable) and tools for obtaining dry or burnable material from nature. All persons must understand the need to warm up fuel to get it burning. Training on how to start and keep a fire going is recommended. (This type of training is needed by many individuals.) Fire must be in association with shelter for warmth and protection.

Rule: Signalling		
Geographic Area	Season	Equipment and other items
West Coast, British Columbia	All seasons	Signalling is very difficult unless near a river, stream or treeless hillside (too many trees). When the sun shines, the best means is a signal mirror (sometimes called a <i>heliograph</i>). It is effective over 22 mi.—far beyond where you can see or hear an aircraft. Fire and smoke are normally ignored by most fly-by aircraft; they are also hard to see. The eight-foot by eight-foot orange panel can be seen well before any other signal except the mirror signal, and it does attract attention.
For all areas of Canada	All seasons	Pyrotechnics In the hands of a trained person, pyrotechnics can be very good. In hands of a novice, they can reduce chances of survival. Pencil pyrotechnics will not go above a 30ft tree in winter (cold makes them useless). For night signalling, a good strobe light can be seen on a clear night up to eight miles away. A flashlight is effective for about one-half mile. One must use judgment to provide equipment in keeping with the forecast weather.

Rule: Purified Water		
Geographic Area	Season	Equipment and other items
For all areas of Canada	All seasons	Canada possesses the purest water in the world; however, in some areas water can be contaminated by dead animals or for other reasons. We need some way of providing safe drinkable water. Solution: Water purification tablets or other methods prescribed by a pharmacist. If boiling water is the preferred method, you need a fire and a good container for boiling water (a billy kettle). If you do not have a suiTable container, you cannot boil water. Training is also needed in how to melt snow in a container over a fire.