



Transport Canada
Safety and Security

Transports Canada
Sécurité et sûreté

Road Safety

Sécurité routière

Standards and Regulations Division

TECHNICAL STANDARDS DOCUMENT

No. 105, Revision 4

Hydraulic and Electric Brake Systems

The text of this document is based on the U.S. *Code of Federal Regulations*, Title 49, Part 571, Federal Motor Vehicle Safety Standard No. 105, Hydraulic and electric brake systems, revised as of October 1, 2004, and the Final Rules published in the *Federal Register* on December 17, 2004 (Vol. 69, No. 242, p. 75486) and on June 30, 2005 (Vol. 70, No. 125, p. 37706).

Publication Date: December 10, 2005
Effective Date: December 10, 2005
Mandatory Compliance Date: June 30, 2006

Standards Research and Development Branch
Road Safety and Motor Vehicle Regulation Directorate
TRANSPORT CANADA
Ottawa, Ontario
K1A 0N5

Technical Standards Document
Number 105, Revision 4
Hydraulic and Electric Brake Systems
(Ce document est aussi disponible en français.)

Introduction

As defined by section 12 of the *Motor Vehicle Safety Act*, a Technical Standards Document (TSD) is a document that reproduces an enactment of a foreign government (e.g. a Federal Motor Vehicle Safety Standard issued by the U.S. National Highway Traffic Safety Administration). According to the Act, the *Motor Vehicle Safety Regulations* may alter or override some provisions contained in a TSD or specify additional requirements; consequently, it is advisable to read a TSD in conjunction with the Act and its counterpart Regulation. As a guide, where the corresponding Regulation contains additional requirements, footnotes indicate the amending subsection number.

TSDs are revised from time to time in order to incorporate amendments made to the reference document, at which time a Notice of Revision is published in the *Canada Gazette*, Part I. All TSDs are assigned a revision number, with “Revision 0” designating the original version.

Identification of Changes

In order to facilitate the incorporation of a TSD, certain non-technical changes may be made to the foreign enactment. These may include the deletion of words, phrases, figures, or sections that do not apply under the Act or Regulations, the conversion of imperial to metric units, the deletion of superseded dates, and minor changes of an editorial nature. Additions are underlined, and provisions that do not apply are ~~stroked through~~. Where an entire section has been deleted, it is replaced by: “[CONTENT DELETED]”. Changes are also made where there is a reporting requirement or reference in the foreign enactment that does not apply in Canada. For example, the name and address of the United States Department of Transportation are replaced by those of the Department of Transport.

Effective Date and Mandatory Compliance Date

The effective date of a TSD is the date of publication of its incorporating regulation or of the notice of revision in the *Canada Gazette*, and the date as of which voluntary compliance is permitted. The mandatory compliance date is the date upon which compliance with the requirements of the TSD is obligatory. If the effective date and mandatory compliance date are different, manufacturers may follow the requirements that were in force before the effective date, or those of the TSD, until the mandatory compliance date.

In the case of an initial TSD, or when a TSD is revised and incorporated by reference by an amendment to the Regulations, the mandatory compliance date is as specified in the Regulations, and it may be the same as the effective date. When a TSD is revised with no

corresponding changes to the incorporating Regulations, the mandatory compliance date is six months after the effective date.

Official Version of Technical Standards Documents

Technical Standards Documents may be consulted electronically in both HTML and Portable Document Format (PDF) on the Department of Transport's Web site at <http://www.tc.gc.ca/eng/acts-regulations/regulations-crc-c1038.htm>. The PDF version is a replica of the TSD as published by the Department and is to be used for the purposes of legal interpretation and application. The HTML version is provided for information purposes only.

(Original signed by)

Director, Standards Research and Development
for the Minister of Transport,
Ottawa, Ontario

TABLE OF CONTENTS

Technical Standards Document Number 105, Revision 4

HYDRAULIC AND ELECTRIC BRAKE SYSTEMS

<i>Introduction</i> _____	<i>i</i>
<i>S1. Scope</i> _____	<i>1</i>
<i>S2. Purpose</i> _____	<i>1</i>
<i>S3. Application</i> _____	<i>1</i>
<i>S4. Definitions</i> _____	<i>1</i>
<i>S5. Requirements</i> _____	<i>4</i>
S5.1 Service brake systems _____	4
S5.2 Parking brake system _____	10
S5.3 Brake system indicator lamp _____	11
S5.4 Reservoirs _____	14
S5.5 Antilock and variable brake proportioning systems _____	15
S5.6 Brake system integrity _____	15
<i>S6. Test conditions</i> _____	<i>15</i>
S6.1 Vehicle <u>mass weight</u> _____	16
S6.2 Electric vehicles and electric brakes _____	16
S6.3 Tire inflation pressure _____	18
S6.4 Transmission selector control _____	18
S6.5 Engine _____	18
S6.6 Vehicle openings _____	18
S6.7 Ambient temperature _____	18
S6.8 Wind velocity _____	18
S6.9 Road surface _____	18
S6.10 Vehicle position and wheel lockup restrictions _____	19
S6.11 Thermocouples _____	20
S6.12 Initial brake temperature _____	20
S6.13 Control forces _____	20
S6.14 Special drive conditions _____	20

S6.15 Selection of compliance options	20
S7. Test procedures and sequence	20
S7.1 Brake warming	23
S7.2 Pretest instrumentation check	23
S7.3 Service brake system — First (preburnish) effectiveness test	23
S7.4 Service brake system — Burnish procedure	23
S7.5 (a) Stability and control during braking (vehicles with a GVWR greater than 4 536 kg [10,000 lb.])	24
S7.5 (b) Service brake system — Second effectiveness test	24
S7.6 First reburnish	24
S7.7 Parking brake test	24
S7.8 Service brake system — Lightly loaded vehicle (third effectiveness) test	26
S7.9 Service brake system test — Partial failure	27
S7.10 Service brake system — Inoperative brake power unit or brake power assist unit test	28
S7.11 Service brake system — First fade and recovery test	29
S7.12 Service brake system — Second reburnish	30
S7.13 Service brake system — Second fade and recovery test	30
S7.14 Third reburnish	30
S7.15 Service brake system — Fourth effectiveness test	30
S7.16 Service brake system — Water recovery test	30
S7.17 Spike stops	31
S7.18 Final inspection	31
S7.19 Moving barrier test	31

LIST OF FIGURES AND TABLES

Figure 1 — Typical Plug Type of Thermocouple Installations	22
Figure 2 — Location for Measuring Brake Application Force on Hand Brakes	25
Table I — Brake Test Procedure Sequence and Requirements	33
Table II — Stopping Distances	34
Table III — Inoperative Brake Power Assist and Brake Power Units	36
Table IV	37

Technical Standards Document Number 105, Revision 4

HYDRAULIC AND ELECTRIC BRAKE SYSTEMS

The text of this document is based on the U.S. *Code of Federal Regulations*, Title 49, Part 571, Federal Motor Vehicle Safety Standard No. 105, Hydraulic and electric brake systems, revised as of October 1, 2004, and the Final Rules published in the *Federal Register* on December 17, 2004 (Vol. 69, No. 242, p. 75486) and on June 30, 2005 (Vol. 70, No. 125, p. 37706).

S1. Scope

This Technical Standards Document (TSD) standard specifies requirements for hydraulic and electric service brake systems, and associated parking brake systems.

S2. Purpose

The purpose of this TSD standard is to insure safe braking performance under normal and emergency conditions.

S3. Application

- (1)
 - (2)
 - (3)
- [CONTENT DELETED] For applicability, see Schedule III and section 105 of Schedule IV to the *Motor Vehicle Safety Regulations*.

S4. Definitions

* **Antilock brake system** or **ABS** ~~means a portion of a service brake system that automatically controls the degree of rotational wheel slip during braking by:~~

- ~~(1) sensing the rate of angular rotation of the wheels;~~
- ~~(2) transmitting signals regarding the rate of wheel angular rotation to one or more controlling devices which interpret those signals and generate responsive controlling output signals; and~~
- ~~(3) transmitting those controlling signals to one or more modulators which adjust brake actuating forces in response to those signals.~~

(dispositif de frein antiblocage ou ABS)

* **Backup system** ~~means a portion of a service brake system, such as a pump, that automatically supplies energy, in the event of a primary brake power source failure.~~

(système de secours)

* Please see subsection 2(1) of the *Motor Vehicle Safety Regulations* for the applicable definition.

* **Brake power assist unit** means a device installed in a hydraulic brake system that reduces the operator effort required to actuate the system, and that if inoperative does not prevent the operator from braking the vehicle by a continued application of muscular force on the service brake control. (*unité d'assistance de frein*)

* **Brake power unit** means a device installed in a brake system that provides the energy required to actuate the brakes, either directly or indirectly through an auxiliary device, with the operator action consisting only of modulating the energy application level. (*unité de servo-frein*)

Directly controlled wheel means a wheel for which the degree of rotational wheel slip is sensed, either at that wheel or on the axle shaft for that wheel, and corresponding signals are transmitted to one or more modulators that adjust the brake actuating forces at that wheel. Each modulator may also adjust the brake actuating forces at other wheels that are on the same axle or in the same axle set in response to the same signal or signals. (*roue commandée directement*)

Electric vehicle or EV means a motor vehicle that is powered by an electric motor drawing current from rechargeable storage batteries, fuel cells, or other portable sources of electrical current, and which may include a non-electrical source of power designed to charge batteries and components thereof. (*véhicule électrique ou EV*)

Electrically actuated service brakes means service brakes that utilize electrical energy to actuate the foundation brakes. (*freins de service électriques*)

Full brake application means a brake application in which the force on the brake pedal reaches 667.2 N (150 lb.) within 0.3 seconds from the point of application of force to the brake control. (*application complète des freins*)

* **Hydraulic brake system** means a system that uses hydraulic fluid as a medium for transmitting force from a service brake control to the service brake, and that may incorporate a brake power assist unit, or a brake power unit. (*système de freinage hydraulique*)

Indirectly controlled wheel means a wheel at which the degree of rotational wheel slip is not sensed, but at which the modulator of an antilock braking system adjusts its brake actuating forces in response to signals from one or more sensed wheels. (*roue commandée indirectement*)

Initial brake temperature means the average temperature of the service brakes on the hottest axle of the vehicle 0.32 km (0.2 mi.) before any brake application. (*température initiale des freins*)

* Please see subsection 2(1) of the *Motor Vehicle Safety Regulations* for the applicable definition.

Lightly loaded vehicle mass weight means:

- (a) For vehicles with a GVWR of 4 536 kg (10,000 lb.) or less, unloaded vehicle weight plus 181.4 kg (400 lb.) (including driver and instrumentation);
- (b) For vehicles with a GVWR greater than 4 536 kg (10,000 lb.), unloaded vehicle weight plus 226.8 kg (500 lb.) (including driver and instrumentation).

(masse du véhicule avec charge légère)

Maximum drive-through speed means the highest possible constant speed at which the vehicle can be driven through 61 m (200 feet) of a 152.4-m (500-foot) radius curve arc without leaving the 3.66-m (12-foot) lane. *(vitesse maximale en virage)*

~~* **Motor home** means a motor vehicle with motive power that is designed to provide temporary residential accommodations, as evidenced by the presence of at least four of the following facilities: cooking; refrigeration or ice box; self-contained toilet; heating and/or air conditioning; a potable water supply system including a faucet and a sink; and a separate 110-125 volt electric power supply and/or an LP gas supply. *(autocaravane)*~~

Parking mechanism means a component or subsystem of the drive train that locks the drive train when the transmission control is placed in a parking or other gear position and the ignition key is removed. *(dispositif de stationnement)*

Peak friction coefficient or **PFC** means the ratio of the maximum value of braking test wheel longitudinal force to the simultaneous vertical force occurring prior to wheel lockup, as the braking torque is progressively increased. *(coefficient maximal de friction ou PFC)*

Pressure component means a brake system component that contains the brake system fluid and controls or senses the fluid pressure. *(élément sous pression)*

Regenerative braking system or **RBS** means an electrical energy system that is installed in an EV for recovering or dissipating kinetic energy, and which uses the propulsion motor(s) as a retarder for partial braking of the EV while returning electrical energy to the propulsion batteries or dissipating electrical energy. *(système de freinage à récupération ou RBS)*

Skid number means the frictional resistance of a pavement measured in accordance with American Society for Testing and Materials (ASTM) Method E 274-70 (as revised July 1974) at 64.4 km/h (40 mph), omitting water delivery as specified in paragraphs 7.1 and 7.2 of that method. *(coefficient de glissance)*

~~* **Snub** means the braking deceleration of a vehicle from a higher reference speed to a lower reference speed that is greater than zero. *(ralentissement)*~~

* Please see subsection 2(1) of the *Motor Vehicle Safety Regulations* for the applicable definition.

* **Spike stop** means a stop resulting from the application of 200 lbs of force on the service brake control in 0.08 s. (*arrêt d'urgence*)

* **Split service brake system** means a brake system consisting of two or more subsystems actuated by a single control, designed so that a single failure in any subsystem (such as a leakage type failure of a pressure component of a hydraulic subsystem except structural failure of a housing that is common to two or more subsystems, or an electrical failure in an electric subsystem) does not impair the operation of any other subsystem. (*système de frein de service partagé*)

* **Stopping distance** means the distance traveled by a vehicle from the point of application of force to the brake control to the point at which the vehicle reaches a full stop. (*distance d'arrêt*)

Tandem axle means a group of two or more axles placed in close arrangement, one behind the other, with the centerlines of adjacent axles not more than 1.83 m (72 in.) apart. (*essieu tandem*)

* **Variable brake proportioning system** means a system that has one or more proportioning devices which automatically change the brake pressure ratio between any two or more wheels to compensate for changes in wheel loading due to static load changes and/or dynamic weight transfer, or due to deceleration. (*compensateur de freinage*)

Wheel lockup means 100 percent wheel slip. (*blocage des roues*)

S5. Requirements

S5.1 Service brake systems

Each vehicle must be equipped with a service brake system acting on all wheels. Wear of the service brake must be compensated for by means of a system of automatic adjustment. Each passenger car and each multipurpose passenger vehicle, truck, and bus with a GVWR of 4 536 kg (10,000 lb.) or less must be capable of meeting the requirements of S5.1.1 through S5.1.6 under the conditions prescribed in S6, when tested according to the procedures and in the sequence set forth in S7. ** Each school bus with a GVWR greater than 4 536 kg (10,000 lb.) must be capable of meeting the requirements of S5.1.1 through S5.1.5 and S5.1.7 under the conditions specified in S6, when tested according to the procedures and in the sequence set forth in S7. Each multipurpose passenger vehicle, truck, and bus (other than a school bus) with a GVWR greater than 4 536 kg (10,000 lb.) must be capable of meeting the requirements of S5.1.1, S5.1.2, S5.1.3, and S5.1.7 under the conditions specified in S6, when tested according to the procedures and in the sequence set forth in S7. Except as noted in S5.1.1.2 and S5.1.1.4, if a vehicle is incapable of attaining a speed specified in S5.1.1, S5.1.2, S5.1.3, or S5.1.6,

* Please see subsection 2(1) of the *Motor Vehicle Safety Regulations* for the applicable definition.

** Please see Table I at the end of this TSD for a summary of the brake test sequence and requirements.

its service brakes must be capable of stopping the vehicle from the multiple of 8.05 km/h (5 mph) that is 6.44 to 12.88 km/h (4 to 8 mph) less than the speed attainable in 3.2 km (2 mi.), within distances that do not exceed the corresponding distances specified in Table II. If a vehicle is incapable of attaining a speed specified in S5.1.4 in the time or distance interval set forth, it must be tested at the highest speed attainable in the time or distance interval specified.

S5.1.1 Stopping distance

- (a) The service brakes shall be capable of stopping each vehicle with a GVWR of less than 3 629 kg (8,000 lb.), and each school bus with a GVWR between 3 629 kg (8,000 lb.) and 4 536 kg (10,000 lb.), in four effectiveness tests within the distances and from the speeds specified in S5.1.1.1, S5.1.1.2, S5.1.1.3, and S5.1.1.4.
- (b) The service brakes shall be capable of stopping each vehicle with a GVWR of between 3 629 kg (8,000 lb.) and 4 536 kg (10,000 lb.), other than a school bus, in three effectiveness tests within the distances and from the speeds specified in S5.1.1.1, S5.1.1.2, and S5.1.1.4.
- (c) The service brakes shall be capable of stopping each vehicle with a GVWR greater than 4 536 kg (10,000 lb.) in two effectiveness tests within the distances and from the speeds specified in S5.1.1.2 and S5.1.1.3. Each school bus with a GVWR greater than 4 536 kg (10,000 lb.) ~~manufactured after January 12, 1996, and before March 1, 1999, and~~ which is equipped with an antilock brake system may comply with paragraphs S5.1.1.2 and S5.5.1 rather than the first effectiveness test, as specified in S5.1.1.1. Each school bus with a GVWR greater than 4 536 kg (10,000 lb.) ~~manufactured on or after March 1, 1999,~~ shall be capable of meeting the requirements of S5.1.1 through S5.1.5, under the conditions prescribed in S6, when tested according to the procedures and in the sequence set forth in S7.

S5.1.1.1 In the first (preburnished) effectiveness test, the vehicle shall be capable of stopping from 48.3 km/h (30 mph) and 96.6 km/h (60 mph) within the corresponding distances specified in Column I of Table II.

S5.1.1.2 In the second effectiveness test, each vehicle with a GVWR of 4 536 kg (10,000 lb.) or less and each school bus with a GVWR greater than 4 536 kg (10,000 lb.) shall be capable of stopping from 48.3 km/h and 96.6 km/h (30 mph and 60 mph), and each vehicle with a GVWR greater than 4 536 kg (10,000 lb.) (other than a school bus) shall be capable of stopping from 96.6 km/h (60 mph), within the corresponding distances specified in Column II of Table II. If the speed attainable in 3.2 km (2 mi.) is not less than 135.2 km/h (84 mph), a passenger car or other vehicle with a GVWR of 4 536 kg (10,000 lb.) or less shall also be capable of stopping from 128.8 km/h (80 mph) within the corresponding distances specified in Column II of Table II.

S5.1.1.3 In the third effectiveness test, the vehicle shall be capable of stopping at lightly loaded vehicle ~~mass weight~~ from 96.6 km/h (60 mph) within the corresponding distance specified in Column III of Table II.

S5.1.1.4 In the fourth effectiveness test, a vehicle with a GVWR of 4 536 kg (10,000 lb.) or less shall be capable of stopping from 48.3 and 96.6 km/h (30 and 60 mph) within the corresponding distances specified in Column I of Table II. If the speed attainable in 3.2 km (2 mi.) is not less than 135.2 km/h (84 mph), a passenger car, or other vehicle with a GVWR of 4 536 kg (10,000 lb.) or less, shall also be capable of stopping from 128.8 km/h (80 mph) within the corresponding distance specified in Column I of Table II. If the speed attainable in 3.2 km (2 mi.) is not less than 159.3 km/h (99 mph), a passenger car shall, in addition, be capable of stopping from the applicable speed indicated below, within the corresponding distance specified in Column I of Table II.

Speed Attainable in <u>3.2 km</u> (2 mi.)	Required to Stop From
Not less than <u>159.3 km/h</u> (99 mph) but less than <u>167.4 km/h</u> (104 mph)	<u>153 km/h</u> (95 mph)
<u>167.4 km/h</u> (104 mph) or more	<u>161 km/h</u> (100 mph)

For an EV, the speed attainable in 3.2 km (2 mi.) is determined with the propulsion batteries at a state of charge of not less than 95 percent at the beginning of the run.

S5.1.2 Partial failure

S5.1.2.1 In vehicles manufactured with a split service brake system, in the event of a rupture or leakage type of failure in a single subsystem, other than a structural failure of a housing that is common to two or more subsystems, the remaining portion(s) of the service brake system shall continue to operate and shall be capable of stopping a vehicle from 96.6 km/h (60 mph) within the corresponding distance specified in Column IV of Table II.

S5.1.2.2 In vehicles not manufactured with a split service brake system, in the event of any one rupture or leakage type of failure in any component of the service brake system, the vehicle shall, by operation of the service brake control, be capable of stopping 10 times consecutively from 96.6 km/h (60 mph) within the corresponding distance specified in Column IV of Table II.

S5.1.2.3 For a vehicle manufactured with a service brake system in which the brake signal is transmitted electrically between the brake pedal and some or all of the foundation brakes, regardless of the means of actuation of the foundation brakes, the vehicle shall be capable of stopping from 96.6 km/h (60 mph) within the corresponding distance specified in Column IV of Table II with any single failure in any circuit that electrically transmits the brake signal, and with all other systems intact.

S5.1.2.4 For an EV manufactured with a service brake system that incorporates RBS, the vehicle shall be capable of stopping from 96.6 km/h (60 mph) within the corresponding distance specified in Column IV of Table II with any single failure in the RBS, and with all other systems intact.

S5.1.3 Inoperative brake power assist unit or brake power unit. A vehicle equipped with one or more brake power assist units shall meet the requirements of either S5.1.3.1, S5.1.3.2, or S5.1.3.4 (chosen at the option of the manufacturer), and a vehicle equipped with one or more brake power units shall meet the requirements of either S5.1.3.1, S5.1.3.3, or S5.1.3.4 (chosen at the option of the manufacturer).

S5.1.3.1 The service brakes on a vehicle equipped with one or more brake power assist units or brake power units, with one such unit inoperative and depleted of all reserve capability, shall be capable of stopping a vehicle from 96.6 km/h (60 mph) within the corresponding distance specified in Column IV of Table II.

S5.1.3.2 Brake power assist units. The service brakes on a vehicle equipped with one or more brake power assist units, with one such unit inoperative, shall be capable of stopping a vehicle from 96.6 km/h (60 mph):

- (a) In six consecutive stops at an average deceleration for each stop that is not lower than that specified in Column I of Table III, when the inoperative unit is not initially depleted of all reserve capability; and
- (b) In a final stop, at an average deceleration that is not lower than 2.13 m/s² (7 fpsps) for passenger cars (equivalent stopping distance 168.9 m [554 ft.]) or 1.83 m/s² (6 fpsps) for vehicles other than passenger cars (equivalent stopping distance 197 m [646 ft.]), as applicable, when the inoperative unit is depleted of all reserve capacity.

S5.1.3.3 Brake power units. The service brakes of a vehicle equipped with one or more brake power units with an accumulator-type reserve system, with any one failure in any one unit shall be capable of stopping the vehicle from 96.6 km/h (60 mph):

- (a) In 10 consecutive stops at an average deceleration for each stop that is not lower than that specified in Column II of Table III, when the unit is not initially depleted of all reserve capability; and
- (b) In a final stop, at an average deceleration that is not lower than 2.13 m/s² (7 fpsps) for passenger cars (equivalent stopping distance 168.9 m [554 ft.]) or 1.83 m/s² (6 fpsps) for vehicles other than passenger cars (equivalent stopping distance 197 m [646 ft.]), as applicable, when the inoperative unit is depleted of all reserve capacity.

S5.1.3.4 Brake power assist and brake power units. The service brakes of a vehicle equipped with one or more brake power assist units or brake power units with a backup system, with one brake power assist unit or brake power unit inoperative and depleted of all reserve capability and with only the backup system operating in the failed subsystem, shall be capable of stopping the vehicle from 96.6 km/h (60 mph) in 15 consecutive stops

at an average deceleration for each stop that is not lower than 3.66 m/s² (12 fpsps) (equivalent stopping distance 98.5 m [323 ft.]).

S5.1.3.5 *Electric brakes.* Each vehicle with electrically actuated service brakes (brake power unit) shall comply with the requirements of S5.1.3.1 with any single electrical failure in the electrically actuated service brakes and all other systems intact.

S5.1.4 *Fade and recovery.* The service brakes shall be capable of stopping each vehicle in two fade and recovery tests as specified below.

S5.1.4.1 The control force used for the baseline check stops or snubs shall be not less than 44.5 N (10 lb.), nor more than 266.9 N (60 lb.), except that the control force for a vehicle with a GVWR of 4 536 kg (10,000 lb.) or more may be between 44.5 N (10 lb.) and 400.3 N (90 lb.).

S5.1.4.2

- (a) Each vehicle with GVWR of 4 536 kg (10,000 lb.) or less shall be capable of making 5 fade stops (10 fade stops on the second test) from 96.6 km/h (60 mph) at a deceleration not lower than 4.57 m/s² (15 fpsps) for each stop, followed by 5 fade stops at the maximum deceleration attainable from 1.52 to 4.57 m/s² (5 to 15 fpsps).
- (b) Each vehicle with a GVWR greater than 4 536 kg (10,000 lb.) shall be capable of making 10 fade snubs (20 fade snubs on the second test) from 64.4 km/h to 32.2 km/h (40 mph to 20 mph) at 3.05 m/s² (10 fpsps) for each snub.

S5.1.4.3

- (a) Each vehicle with a GVWR of 4 536 kg (10,000 lb.) or less shall be capable of making five recovery stops from 48.3 km/h (30 mph) at 3.05 m/s² (10 fpsps) for each stop, with a control force application that falls within the following maximum and minimum limits:
 - (1) A maximum for the first four recovery stops of 667.2 N (150 lb.), and for the fifth stop, of 89 N (20 lb.) more than the average control force for the baseline check; and
 - (2) A minimum of:
 - (A) The average control force for the baseline check minus 44.5 N (10 lb.), or
 - (B) The average control force for the baseline check times 0.60, whichever is lower (but in no case lower than 22.2 N [5 lb.]).
- (b) Each vehicle with a GVWR of more than 4 536 kg (10,000 lb.) shall be capable of making five recovery snubs from 64.4 km/h to 32.2 km/h (40 mph to 20 mph) at 3.05 m/s² (10 fpsps) for each snub, with a control force application that falls within the following maximum and minimum limits:

- (1) A maximum for the first four recovery snubs of 667.2 N (150 lb.), and for the fifth snub, of 89 N (20 lb.) more than the average control force for the baseline check (but in no case more than 444.8 N [100 lb.]); and
- (2) A minimum of:
 - (A) The average control force for the baseline check minus 44.5 N (10 lb.), or
 - (B) The average control force for the baseline check times 0.60, whichever is lower (but in no case lower than 22.2 N [5 lb.]).

S5.1.5 Water recovery. The service brakes shall be capable of stopping each vehicle in a water recovery test, as specified below.

S5.1.5.1 The control force used for the baseline check stops or snubs shall be not less than 44.5 N (10 lb.), nor more than 266.9 N (60 lb.), except that the control force for a vehicle with a GVWR of 4 536 kg (10,000 lb.) or more may be between 44.8 N and 400.3 N (10 lb. and 90 lb.).

S5.1.5.2

- (a) After being driven for 2 minutes at a speed of 8.05 km/h (5 mph) in any combination of forward and reverse directions through a trough having a water depth of 152.4 mm (6 in.), each vehicle with a GVWR of 4 536 kg (10,000 lb.) or less shall be capable of making five recovery stops from 48.3 km/h (30 mph) at 3.05 m/s² (10 fpsps) for each stop with a control force application that falls within the following maximum and minimum limits:
 - (1) A maximum for the first four recovery stops of 667.2 N (150 lb.), and for the fifth stop, of 200.2 N (45 lb.) more than the average control force for the baseline check (but in no case more than 400.3 N [90 lb.]), ~~except that the maximum control force for the fifth stop in the case of a vehicle manufactured before September 1, 1976, shall be not more than plus 60 lb. of the average control force for the baseline check (but in no case more than 110 lb.).~~
 - (2) A minimum of:
 - (A) The average control force for the baseline check minus 44.5 N (10 lb.), or
 - (B) The average control force for the baseline check times 0.60, whichever is lower (but in no case lower than 22.2 N [5 lb.]).
- (b) After being driven for 2 minutes at a speed of 8.05 km/h (5 mph) in any combination of forward and reverse directions through a trough having a water depth of 152.4 mm (6 in.), each vehicle with a GVWR of more than 4 536 kg (10,000 lb.) shall be capable of making five recovery stops from 48.3 km/h (30 mph) at 3.05 m/s² (10 fpsps) for each stop with a control force application that falls within the following maximum and minimum limits:
 - (1) A maximum for the first four recovery stops of 667.2 N (150 lb.), and for the fifth stop, of 266.9 N (60 lb.) more than the average control force for the baseline check (but in no case more than 489.3 N [110 lb.]); and

(2) A minimum of:

- (A) The average control force for the baseline check minus 44.5 N (10 lb.), or
- (B) The average control force for the baseline check times 0.60, whichever is lower (but in no case lower than 22.2 N [5 lb.]).

S5.1.6 Spike stops. Each vehicle with a GVWR of 4 536 kg (10,000 lb.) or less shall be capable of making 10 spike stops from 48.3 km/h (30 mph), followed by 6 effectiveness (check) stops from 96.6 km/h (60 mph), at least one of which shall be within a corresponding stopping distance specified in Column I of Table II.

S5.1.7 Stability and control during braking. When stopped four consecutive times under the conditions specified in S6, each vehicle with a GVWR greater than 4 536 kg (10,000 lb.) manufactured on or after July 1, 2005, and each vehicle with a GVWR greater than 4 536 kg (10,000 lb.) manufactured in two or more stages on or after July 1, 2006, shall stop from 48.3 km/h (30 mph) or 75 percent of the maximum drive-through speed, whichever is less, at least three times within the 3.66-m (12-foot) lane, without any part of the vehicle leaving the roadway. Stop the vehicle with the vehicle at its lightly loaded vehicle mass weight, or at the manufacturer's option, at its lightly loaded vehicle mass weight plus not more than an additional 453.6 kg (1,000 lb.) for a roll bar structure on the vehicle.

S5.2 Parking brake system

Each vehicle shall be manufactured with a parking brake system of a friction type with a solely mechanical means to retain engagement, which shall under the conditions of S6, when tested according to the procedures specified in S7, meet the requirements specified in S5.2.1, S5.2.2, or S5.2.3, as appropriate, with the system engaged:

- (a) In the case of a vehicle with a GVWR of 4 536 kg (10,000 lb.) or less, with a force applied to the control not to exceed 556 N (125 lb.) for a foot-operated system and 400.3 N (90 lb.) for a hand-operated system; and
- (b) In the case of a vehicle with a GVWR greater than 4 536 kg (10,000 lb.) with a force applied to the control not to exceed 667.2 N (150 lb.) for a foot-operated system and 556 N (125 lb.) for a hand-operated system.

S5.2.1 Except as provided in S5.2.2, the parking brake system on a passenger car and on a school bus with a GVWR of 4 536 kg (10,000 lb.) or less shall be capable of holding the vehicle stationary (to the limit of traction of the braked wheels) for 5 minutes, in both a forward and reverse direction, on a 30 percent grade.

S5.2.2 A vehicle of a type described in S5.2.1, at the option of the manufacturer, may meet the requirements of S5.2.2.1, S5.2.2.2, and S5.2.2.3 instead of the requirements of S5.2.1 if:

- (a) The vehicle has a transmission or transmission control which incorporates a parking mechanism, and
- (b) The parking mechanism must be engaged before the ignition key can be removed.

S5.2.2.1 The vehicle's parking brake and parking mechanism, when both are engaged, shall be capable of holding the vehicle stationary (to the limit of traction of the braked wheels) for 5 minutes, in both forward and reverse directions, on a 30 percent grade.

S5.2.2.2 The vehicle's parking brake, with the parking mechanism not engaged, shall be capable of holding the vehicle stationary for 5 minutes, in both forward and reverse directions, on a 20 percent grade.

S5.2.2.3 With the parking mechanism engaged and the parking brake not engaged, the parking mechanism shall not disengage or fracture in a manner permitting vehicle movement when the vehicle is impacted at each end, on a level surface, by a barrier moving at 4.03 km/h (2.5 mph).

S5.2.3

- (a) The parking brake system on a multipurpose passenger vehicle, truck, or bus (other than a school bus) with a GVWR of 4 536 kg (10,000 lb.) or less shall be capable of holding the vehicle stationary for 5 minutes, in both forward and reverse directions, on a 20 percent grade.
- (b) The parking brake system on a multipurpose passenger vehicle, truck, or bus (including a school bus) with a GVWR greater than 4 536 kg (10,000 lb.) shall be capable of holding the vehicle stationary for 5 minutes, in both forward and reverse directions, on a 20 percent grade.

S5.3 Brake system indicator lamp

Each vehicle shall have a brake system indicator lamp or lamps, mounted in front of and in clear view of the driver, which meet the requirements of S5.3.1 through S5.3.5. A vehicle with a GVWR of 4 536 kg (10,000 lb.) or less may have a single common indicator lamp. A vehicle with a GVWR of greater than 4 536 kg (10,000 lb.) may have an indicator lamp which is common for gross loss of pressure, drop in the level of brake fluid, or application of the parking brake, but shall have a separate indicator lamp for antilock brake system malfunction. However, the options provided in S5.3.1(a) shall not apply to a vehicle manufactured without a split service brake system; such a vehicle shall, to meet the requirements of S5.3.1(a), be equipped with a malfunction indicator that activates under the conditions specified in S5.3.1(a)(4). This warning indicator shall, instead of meeting the requirements of S5.3.2 through S5.3.5, activate (while the vehicle remains capable of meeting the requirements of S5.1.2.2 and the ignition switch is in the "on" position) a continuous or intermittent audible signal and a flashing warning light displaying the words "STOP—BRAKE FAILURE" in block capital letters not less than 6.35 mm (0.25 in.) in height.

S5.3.1 An indicator lamp shall be activated when the ignition ("start") switch is in the "on" ("run") position and whenever any of the conditions (a) or (b), (c), (d), (e), (f), and (g) occur:

- (a) A gross loss of pressure (such as caused by rupture of a brake line but not by a structural failure of a housing that is common to two or more subsystems) due to one of the following conditions (chosen at the option of the manufacturer):
- (1) Before or upon application of a differential pressure of not more than 1 550 kPa (225 psi) between the active and failed brake system measured at a master cylinder outlet or a slave cylinder outlet,
 - (2) Before or upon application of 222.4 N (50 lb.) of control force upon a fully manual service brake,
 - (3) Before or upon application of 111.2 N (25 lb.) of control force upon a service brake with a brake power assist unit,
 - (4) When the supply pressure in a brake power unit drops to a level not less than one-half of the normal system pressure.
- (b) A drop in the level of brake fluid in any master cylinder reservoir compartment to less than the recommended safe level specified by the manufacturer or to one-fourth of the fluid capacity of that reservoir compartment, whichever is greater.
- (c) A malfunction that affects the generation or transmission of response or control signals in an antilock brake system, or a total functional electrical failure in a variable brake proportioning system.
- (d) Application of the parking brake.
- (e) For a vehicle with electrically actuated service brakes, failure of the source of electric power to the brakes, or diminution of state of charge of the batteries to less than a level specified by the manufacturer for the purpose of warning a driver of degraded brake performance.
- (f) For a vehicle with electric transmission of the service brake control signal, failure of a brake control circuit.
- (g) For an EV with RBS that is part of the service brake system, failure of the RBS.

S5.3.2

- (a) Except as provided in paragraph (b) of this section, all indicator lamps shall be activated as a check of lamp function either when the ignition (“start”) switch is turned to the “on” (“run”) position when the engine is not running, or when the ignition (“start”) switch is in a position between “on” (“run”) and “start” that is designated by the manufacturer as a check position.
- (b) The indicator lamps need not be activated when a starter interlock is in operation.

S5.3.3

- (a) Each indicator lamp activated due to a condition specified in S5.3.1 shall remain activated as long as the malfunction exists, whenever the ignition (“start”) switch is in the “on” (“run”) position, whether or not the engine is running.

- (b) For vehicles with a GVWR greater than 4 536 kg (10,000 lb.), each message about the existence of a malfunction, as described in S5.3.1(c), shall be stored in the antilock brake system after the ignition switch is turned to the “off” position and the indicator lamp shall be automatically reactivated when the ignition switch is again turned to the “on” position. The indicator lamp shall also be activated as a check of lamp function whenever the ignition is turned to the “on” (“run”) position. The indicator lamp shall be deactivated at the end of the check of lamp function unless there is a malfunction or a message about a malfunction that existed when the key switch was last turned to the “off” position.

S5.3.4 When an indicator lamp is activated, it may be steady burning or flashing.

S5.3.5

- (a) Each indicator lamp shall display a word, words, or an abbreviation in accordance with the requirements of section 101 of the *Motor Vehicle Safety Regulations Standard No. 101 (49 CFR 571.101)* and/or this section, which shall have letters not less than 3.2 mm (0.125 in.) high and be legible to the driver in daylight when lighted. Words in addition to those required by section 101 of the *Regulations Standard No. 101* and/or this section and symbols may be provided for purposes of clarity.
- (4)* (b) ~~If a single common indicator is used, the lamp shall display the word “Brake”.~~ The letters and background of a single common indicator shall be of contrasting colors, one of which is red.
- (c) (1) If separate indicators are used for one or more of the conditions described in S5.3.1(a) through S5.3.1(g) of this TSD standard, the indicator display shall include the word “Brake” and appropriate additional labeling, except as provided in (c)(1) (A) through (D) of this paragraph.
- (5) (A) If a separate indicator lamp is provided for gross loss of pressure, the words “Brake Pressure” shall be used for S5.3.1(a).
- (5) (B) If a separate indicator lamp is provided for low brake fluid, the words “Brake Fluid” shall be used for S5.3.1(b), except for vehicles using hydraulic system mineral oil.
- (6) (C) If a separate indicator lamp is provided for an antilock system, the single word “Antilock” or “Anti-lock”, or the abbreviation “ABS”, may be used for S5.3.1(c).
- (5) (D) If a separate indicator lamp is provided for application of the parking brake, the single word “Park” may be used for S5.3.1(d).
- (E) If a separate indicator is used for the regenerative brake system, the symbol “RBS” may be used. RBS failure may also be indicated by a lamp displaying the symbol “ABS/RBS.”

* The numbers in parentheses in the margin refer to subsections of section 105 of the Regulations that supersede the requirements of the TSD provision.

- (2) Except for a separate indicator lamp for an antilock system, a regenerative system, or an indicator for both antilock and regenerative system, the letters and background of each separate indicator lamp shall be of contrasting colors, one of which is red. The letters and background of a separate lamp for an antilock system, a regenerative system, or a lamp displaying both an antilock and a regenerative system shall be of contrasting colors, one of which is yellow.

S5.4 Reservoirs

S5.4.1 Master cylinder reservoirs. A master cylinder shall have a reservoir compartment for each service brake subsystem serviced by the master cylinder. Loss of fluid from one compartment shall not result in a complete loss of brake fluid from another compartment.

S5.4.2 Reservoir capacity. Reservoirs, whether for master cylinders or other types of systems, shall have a total minimum capacity equivalent to the fluid displacement resulting when all the wheel cylinders or caliper pistons serviced by the reservoirs move from a new lining, fully retracted position (as adjusted initially to the manufacturer's recommended setting), to a fully worn, fully applied position, as determined in accordance with S7.18(c) of this TSD standard. Reservoirs shall have completely separate compartments for each subsystem, except that, in reservoir systems utilizing a portion of the reservoir for a common supply to two or more subsystems, individual partial compartments shall each have a minimum volume of fluid equal to at least the volume displaced by the master cylinder piston servicing the subsystem, during a full stroke of the piston. Each brake power unit reservoir servicing only the brake system shall have a minimum capacity equivalent to the fluid displacement required to charge the system piston(s) or accumulator(s) to normal operating pressure plus the displacement resulting when all the wheel cylinders or caliper pistons serviced by the reservoir or accumulator(s) move from a new lining, fully retracted position (as adjusted initially to the manufacturer's recommended setting), to a fully worn, fully applied position.

- (7) **S5.4.3 Reservoir labeling.** Each vehicle equipped with hydraulic brakes shall have a brake fluid warning statement that reads as follows, in letters at least 3.2 mm (0.125 in.) high: "WARNING: Clean filler cap before removing. Use only _____ fluid from a sealed container." (Insert the recommended type of brake fluid as specified in 49 CFR 571.116, e.g., "DOT 3".) The lettering shall be:
- Permanently affixed, engraved, or embossed;
 - Located so as to be visible by direct view, either on or within 101.6 mm (4 in.) of the brake fluid reservoir filler plug or cap; and
 - Of a color that contrasts with its background, if it is not engraved or embossed.

S5.5 Antilock and variable brake proportioning systems

S5.5.1 Each vehicle with a GVWR greater than 4 536 kg (10,000 lb.), except for any vehicle with a speed attainable in 3.2 km (2 mi.) of not more than 53.11 km/h (33 mph), shall be equipped with an antilock brake system that directly controls the wheels of at least one front axle and the wheels of at least one rear axle of the vehicle. On each vehicle with a GVWR greater than 4 536 kg (10,000 lb.) but not greater than 8 845 kg (19,500 lb.) and motor homes with a GVWR greater than 4 536 kg (10,000 lb.) but not greater than 10 206 kg (22,500 lb.) manufactured before March 1, 2001, the antilock brake system may also directly control the wheels of the rear drive axle by means of a single sensor in the driveline. Wheels on other axles of the vehicle may be indirectly controlled by the antilock brake system.

S5.5.2 In the event of any failure (structural or functional) in an antilock or variable brake proportioning system, the vehicle shall be capable of meeting the stopping distance requirements specified in S5.1.2 for service brake system partial failure. For an EV that is equipped with both ABS and RBS that is part of the service brake system, the ABS must control the RBS.

S5.6 Brake system integrity

Each vehicle shall be capable of completing all performance requirements of S5 without:

- (a) Detachment or fracture of any component of the braking system, such as brake springs and brake shoe or disc pad facing, other than minor cracks that do not impair attachment of the friction facing. All the mechanical components of the braking system shall be intact and functional. Friction facing tearout (complete detachment of the lining) shall not exceed 10 percent of the lining on any single frictional element.
- (b) Any visible brake fluid or lubricant on the friction surface of the brake, or leakage at the master cylinder or brake power unit reservoir cover, seal, and filler openings.

S6. Test conditions

The performance requirements of S5 shall be met under the following conditions. Where a range of conditions is specified, the vehicle shall be capable of meeting the requirements at all points within the range. Vehicles manufactured in two or more stages may, at the option of the final-stage manufacturer, be demonstrated to comply with this ~~TSD standard~~ by adherence to the instructions of the incomplete vehicle manufacturer provided with the vehicle in accordance with the requirements of subparagraph 6.1(1)(g)(ii) and sections 6.3 and 6.4 of the Motor Vehicle Safety Regulations § 568.4(a)(7)(ii) and § 568.5 of Title 49 of the Code of Federal Regulations.

S6.1 Vehicle mass weight

S6.1.1 Other than tests specified at lightly loaded vehicle mass weight in S7.5(a), S7.7, S7.8, and S7.9, the vehicle is loaded to its GVWR such that the mass weight on each axle as measured at the tire-ground interface is in proportion to its GAWR, except that each fuel tank is filled to any level from 100 percent of capacity (corresponding to full GVWR) to 75 percent. However, if the mass weight on any axle of a vehicle at lightly loaded vehicle mass weight exceeds the axle's proportional share of the gross vehicle weight rating, the load required to reach GVWR is placed so that the mass weight on that axle remains the same as a lightly loaded vehicle mass weight.

S6.1.2 For the applicable tests specified in S7.5(a), S7.7, S7.8, and S7.9, vehicle mass weight is lightly loaded vehicle mass weight, with the added mass weight, except for the roll bar structure allowed for trucks and buses with a GVWR greater than 4 536 kg (10,000 lb.), distributed in the front passenger seat area in passenger cars, multipurpose passenger vehicles, and trucks, and in the area adjacent to the driver's seat in buses.

S6.2 Electric vehicles and electric brakes

S6.2.1 The state of charge of the propulsion batteries is determined in accordance with SAE Recommended Practice J227a, *Electric Vehicle Test Procedure*, February 1976. The applicable sections of J227a are 3.2.1 through 3.2.4, 3.3.1 through 3.3.2.2, 3.4.1, 3.4.2, 4.2.1, 5.2, 5.2.1, and 5.3.

S6.2.2 At the beginning of the first effectiveness test specified in S7.3 and at the beginning of each burnishing procedure, each EV's propulsion battery is at the maximum state of charge recommended by the manufacturer, as stated in the vehicle operator's manual or on a label that is permanently attached to the vehicle, or, if the manufacturer has made no recommendation, at a state of charge of not less than 95 percent. If a battery is replaced rather than recharged, the replacement battery is to be charged and measured for state of charge in accordance with these procedures. During each burnish procedure, each propulsion battery is restored to the recommended state of charge or a state of charge of not less than 95 percent after each increment of 40 burnish stops until each burnish procedure is complete. The batteries may be charged at a more frequent interval if, during a particular 40-stop increment, the EV is incapable of achieving the initial burnish test speed. During each burnish procedure, the propulsion batteries may be charged by an external means or replaced by batteries that are charged to the state of charge recommended by the manufacturer or a state of charge of not less than 95 percent. For EVs having a manual control for setting the level of regenerative braking, the manual control, at the beginning of each burnish procedure, is set to provide maximum regenerative braking throughout the burnish.

S6.2.3 At the beginning of each performance test in the test sequence (S7.3, S7.5, S7.7 through S7.11, and S7.13 through S7.19 of this TSD standard), unless otherwise specified, each propulsion battery of an EV is at the maximum state of charge recommended by the manufacturer, as stated in the vehicle operator's manual or on a label that is permanently attached to the vehicle, or, if the manufacturer has made no

recommendation, at a state of charge of not less than 95 percent. If batteries are replaced rather than recharged, each replacement battery shall be charged and measured for state of charge in accordance with these procedures. No further charging of any propulsion battery occurs during any of the performance tests in the test sequence of this TSD standard. If the propulsion batteries are depleted during a test sequence such that the vehicle reaches automatic shut-down, will not accelerate, or the low state-of-charge warning lamp is illuminated, the vehicle is to be accelerated to brake test speed by auxiliary means.

S6.2.4

- (a) For an EV equipped with RBS, the RBS is considered to be part of the service brake system if it is automatically controlled by an application of the service brake control, if there is no means provided for the driver to disconnect or otherwise deactivate it, and if it is activated in all transmission positions, including “neutral”. The RBS is operational during all burnishes and all tests, except for the test of a failed RBS.
- (b) For an EV equipped with an RBS that is not part of the service brake system, the RBS is operational and set to produce the maximum regenerative braking effect during the burnishes, and is disabled during the test procedures. If the vehicle is equipped with a “neutral” gear that automatically disables the RBS, the test procedures which are designated to be conducted in gear may be conducted in “neutral”.

S6.2.5 For tests conducted in “neutral”, the operator of an EV with no “neutral” position (or other means such as a clutch for disconnecting the drive train from the propulsion motor[s]) does not apply any electromotive force to the propulsion motor(s). Any electromotive force that is applied to the propulsion motor(s) automatically remains in effect unless otherwise specified by the test procedure.

S6.2.6 A vehicle equipped with electrically actuated service brakes also performs the following test series. Conduct 10 stopping tests from a speed of 100 km/h (62.1 mph) or the maximum vehicle speed, whichever is less. At least two of the 10 stopping distances must be less than or equal to 70 meters (230 ft.). The vehicle is loaded to GVWR for these tests and the transmission is in the “neutral” position when the service brake control is actuated and throughout the remainder of the test. The battery or batteries providing power to those electrically actuated brakes, at the beginning of each test, shall be in a depleted state of charge for conditions (a), (b), or (c) of this paragraph, as appropriate. An auxiliary means may be used to accelerate an EV to test speed.

- (a) For an EV equipped with electrically actuated service brakes deriving power from the propulsion batteries, and with automatic shut-down capability of the propulsion motor(s), the propulsion batteries are at not more than five percent above the EV actual automatic shut-down critical value. The critical value is determined by measuring the state of charge of each propulsion battery at the instant that automatic shut-down occurs and averaging the states of charge recorded.

- (b) For an EV equipped with electrically actuated service brakes deriving power from the propulsion batteries, and with no automatic shut-down capability of the propulsion motor(s), the propulsion batteries are at an average of not more than five percent above the actual state of charge at which the brake failure warning signal, required by S5.3.1(e) of this TSD standard, is illuminated.
- (c) For a vehicle which has an auxiliary battery (or batteries) that provides electrical energy to operate the electrically actuated service brakes, the auxiliary battery (batteries) is (are) at (at an average of) not more than five percent above the actual state of charge at which the brake failure warning signal, required by S5.3.1(e) of this TSD standard, is illuminated.

S6.3 Tire inflation pressure

Tire inflation pressure is the pressure recommended by the vehicle manufacturer for the GVWR of the vehicle.

S6.4 Transmission selector control

For S7.3, S7.5, S7.8, S7.15, S7.17, S7.11.1.2, S7.11.2.2, S7.11.3.2, and as required for S7.13, the transmission ~~selector~~ control is in “neutral” for all decelerations. For all other tests during all decelerations, the transmission ~~selector~~ is in the control position, other than overdrive, recommended by the manufacturer for driving on a level surface at the applicable test speed. To avoid engine stall during tests required to be run in gear, a manual transmission may be shifted to “neutral” (or the clutch disengaged) when the vehicle speed decreases to 32.2 km/h (20 mph).

S6.5 Engine

Engine idle speed and ignition timing settings are according to the manufacturer's recommendations. If the vehicle is equipped with an adjustable engine speed governor, it is adjusted according to the manufacturer's recommendation.

S6.6 Vehicle openings

All vehicle openings (doors, windows, hood, trunk, convertible top, cargo doors, etc.) are closed, except as required for instrumentation purposes.

S6.7 Ambient temperature

The ambient temperature is any temperature between 0°C and 37.8°C (32°F and 100°F).

S6.8 Wind velocity

The wind velocity is zero.

S6.9 Road surface

S6.9.1 For vehicles with a GVWR of 4 536 kg (10,000 lb.) or less, road tests are conducted on a 3.66-m (12-ft.) wide, level roadway, having a skid number of 81.

Burnish stops are conducted on any surface. The parking brake test surface is clean, dry, smooth Portland cement concrete.

S6.9.2

- (a) For vehicles with a GVWR greater than 4 536 kg (10,000 lb.), road tests (excluding stability and control during braking tests) are conducted on a 3.66-m (12-foot) wide, level roadway, having a peak friction coefficient of 0.9 when measured using an American Society for Testing and Materials (ASTM) E 1136 standard reference test tire, in accordance with ASTM Method E 1337-90, at a speed of 64.4 km/h (40 mph), without water delivery. Burnish stops are conducted on any surface. The parking brake test surface is clean, dry, smooth, Portland cement concrete.
- (b) For vehicles with a GVWR greater than 4 536 kg (10,000 lb.), stability and control during braking tests are conducted on a 152.4-m (500-foot) radius curved roadway with a wet level surface having a peak friction coefficient of 0.5 when measured on a straight or curved section of the curved roadway using an American Society for Testing and Materials (ASTM) E 1136 standard reference tire, in accordance with ASTM Method E 1337-90, at a speed of 64.4 km/h (40 mph), with water delivery.

S6.10 Vehicle position and wheel lockup restrictions

The vehicle is aligned in the center of the roadway at the start of each brake application. Stops, other than spike stops, are made without any part of the vehicle leaving the roadway.

S6.10.1 For vehicles with a GVWR of 4 536 kg (10,000 lb.) or less, stops are made with wheel lockup permitted only as follows:

- (a) At vehicle speeds above 16.1 km/h (10 mph), there may be controlled wheel lockup on an antilock-equipped axle, and lockup of not more than one wheel per vehicle, uncontrolled by an antilock system. (Dual wheels on one side of an axle are considered a single wheel.)
- (b) At vehicle speeds of 16.1 km/h (10 mph) or less, any wheel may lock up for any duration.
- (c) Unlimited wheel lockup is allowed during spike stops (but not spike check stops), partial failure stops, and inoperative brake power or power assist unit stops.

S6.10.2 For vehicles with a GVWR greater than 4 536 kg (10,000 lb.), stops are made with wheel lockup permitted only as follows:

- (a) At vehicle speeds above 32.2 km/h (20 mph), any wheel on a nonsteerable axle, other than the two rearmost nonliftable, nonsteerable axles, may lock up for any duration. The wheels on the two rearmost nonliftable, nonsteerable axles may lock up according to (b).

- (b) At vehicle speeds above 32.2 km/h (20 mph), one wheel on any axle or two wheels on any tandem may lock up for any duration.
- (c) At vehicle speeds above 32.2 km/h (20 mph), any wheel not permitted to lock in (a) or (b) may lock up repeatedly, with each lockup occurring for a duration of one second or less.
- (d) At vehicle speeds of 32.2 km/h (20 mph) or less, any wheel may lock up for any duration.
- (e) Unlimited wheel lockup is allowed during partial failure stops, and inoperative brake power or power assist stops.

S6.11 Thermocouples

The brake temperature is measured by plug-type thermocouples installed in the approximate center of the facing length and width of the most heavily loaded shoe or disc pad, one per brake, as shown in Figure 1. A second thermocouple may be installed at the beginning of the test sequence if the lining wear is expected to reach a point causing the first thermocouple to contact the metal rubbing surface of a drum or rotor. For centergrooved shoes or pads, thermocouples are installed within 3.2 mm (0.125 in.) to 6.4 mm (0.25 in.) of the groove and as close to the center as possible.

S6.12 Initial brake temperature

Unless otherwise specified the brake temperature is 65.6°C to 93.3°C (150°F to 200°F).

S6.13 Control forces

Unless otherwise specified, the force applied to a brake control is not less than 66.7 N (15 lb.) and not more than 667.2 N (150 lb.).

S6.14 Special drive conditions

A vehicle with a GVWR greater than 4 536 kg (10,000 lb.) equipped with an interlocking axle system or a front wheel drive system that is engaged and disengaged by the driver is tested with the system disengaged.

S6.15 Selection of compliance options

Where manufacturer options are specified, the manufacturer shall select the option by the time it certifies the vehicle and may not thereafter select a different option for the vehicle. Each manufacturer shall, upon request from the Department of Transport National Highway Traffic Safety Administration, provide information regarding which of the compliance options it has selected for a particular vehicle or make/model.

S7. Test procedures and sequence

Each vehicle shall be capable of meeting all the applicable requirements of S5 when tested according to the procedures and sequence set forth below, without replacing any brake system part or making any adjustments to the brake system other than as permitted

in the burnish and reburnish procedures and in S7.9 and S7.10. (For vehicles only having to meet the requirements of S5.1.1, S5.1.2, S5.1.3, and S5.1.7 in section S5.1, the applicable test procedures and sequence are S7.1, S7.2, S7.4, S7.5(b), S7.5(a), S7.8, S7.9, S7.10, and S7.18. However, at the option of the manufacturer, the following test procedure and sequence may be conducted: S7.1, S7.2, S7.3, S7.4, S7.5(b), S7.6, S7.7, S7.5(a), S7.8, S7.9, S7.10, and S7.18. The choice of this option must not be construed as adding to the requirements specified in S5.1.2 and S5.1.3.) Automatic adjusters must remain activated at all times. A vehicle shall be deemed to comply with the stopping distance requirements of S5.1 if at least one of the stops at each speed and load specified in each of S7.3, S7.5(b), S7.8, S7.9, S7.10, S7.15, and S7.17 (check stops) is made within a stopping distance that does not exceed the corresponding distance specified in Table II. When the transmission selector control is required to be in neutral for a deceleration, a stop or snub must be obtained by the following procedures:

- (a) Exceed the test speed by 6.44 to 12.88 km/h (4 to 8 mph);
- (b) Close the throttle and coast in gear to approximately 3.2 km/h (2 mph) above the test speed;
- (c) Shift to neutral; and
- (d) When the test speed is reached, apply the service brakes.

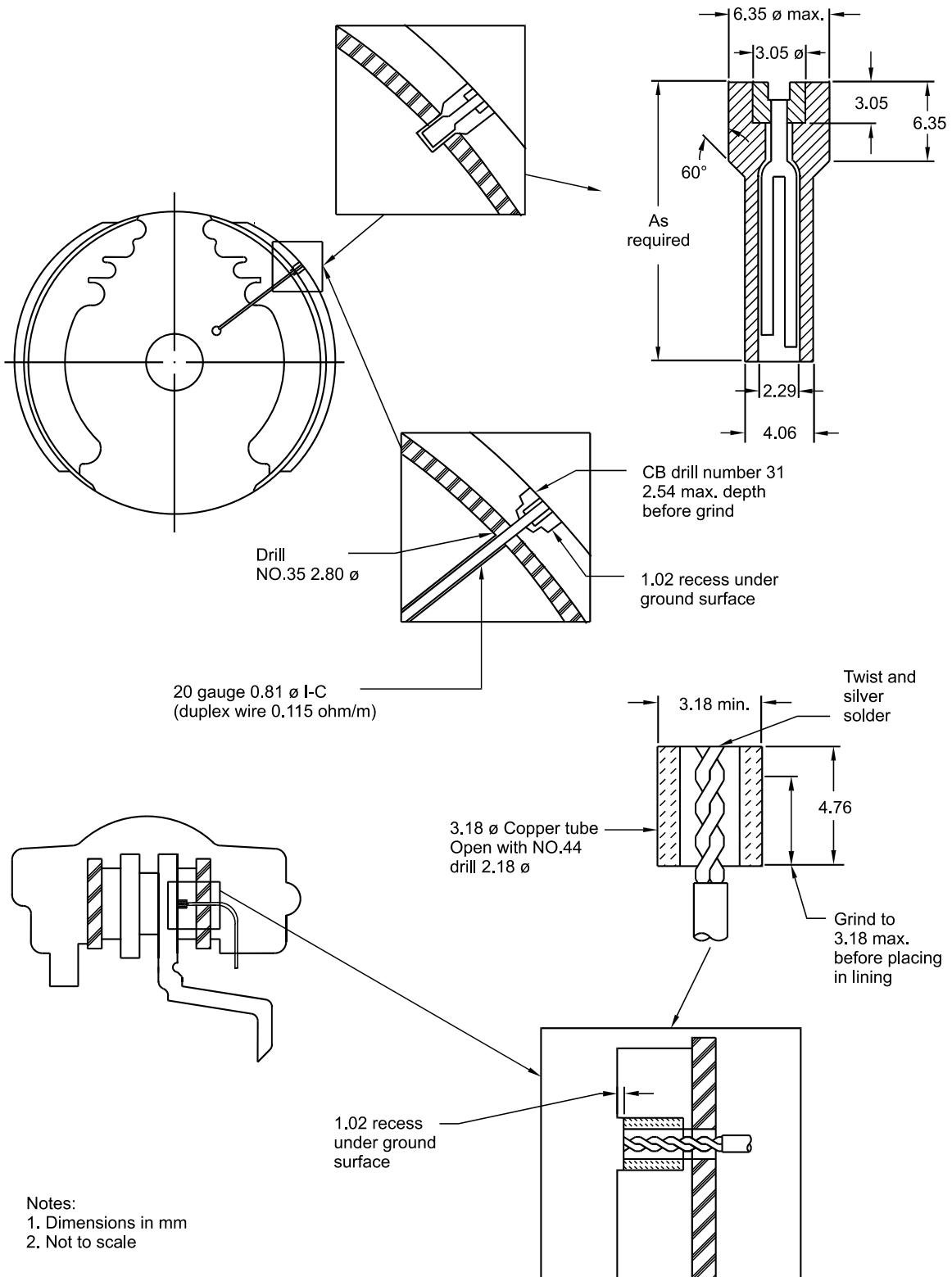

Notes:
 1. Dimensions in mm
 2. Not to scale

Note: The second thermocouple shall be installed at a depth of 2.03 mm (0.080 in.) within 25.4 mm (1 in.) circumferentially of the thermocouple installed at 1.02 mm (0.040 in.) depth.

Figure 1 — Typical Plug Type of Thermocouple Installations

S7.1 Brake warming

If the initial brake temperature for the first stop in a test procedure (other than S7.7 and S7.16) has not been reached, heat the brakes to the initial brake temperature by making not more than 10 snubs from not more than 64.4 to 16.1 km/h (40 to 10 mph), at a deceleration not greater than 3.05 m/s² (10 fpsps).

S7.2 Pretest instrumentation check

Conduct a general check of instrumentation by making not more than 10 stops from a speed of not more than 48.3 km/h (30 mph), or 10 snubs from a speed of not more than 64.4 to 16.1 km/h (40 to 10 mph), at a deceleration of not more than 3.05 m/s² (10 fpsps). If instrument repair, replacement, or adjustment is necessary, make not more than 10 additional stops or snubs after such repair, replacement, or adjustment.

S7.3 Service brake system — First (preburnish) effectiveness test

Make six stops from 48.3 km/h (30 mph). Then make six stops from 96.6 km/h (60 mph).

S7.4 Service brake system — Burnish procedure

S7.4.1 Vehicles with a GVWR of 4 536 kg (10,000 lb.) or less

S7.4.1.1 Burnish. Burnish the brakes by making 200 stops from 64.4 km/h (40 mph) at 3.66 m/s² (12 fpsps) (the 667.2-N [150-lb.] control force limit does not apply here). The interval from the start of one service brake application to the start of the next shall be either the time necessary to reduce the initial brake temperature to between 110°C and 132.2°C (230°F and 270°F) or the distance of 1.6 km (1 mi.), whichever occurs first. Accelerate to 64.4 km/h (40 mph) after each stop and maintain that speed until making the next stop.

S7.4.1.2 Post-burnish brake adjustment. After burnishing, adjust the brakes in accordance with the manufacturer's published recommendations.

S7.4.2 Vehicles with a GVWR greater than 4 536 kg (10,000 lb.)

S7.4.2.1 Burnish. Vehicles are burnished according to the following procedures. Make 500 snubs between 64.4 km/h and 32.2 km/h (40 mph and 20 mph), at a deceleration rate of 3.05 m/s² (10 fpsps). Except where an adjustment is specified, after each brake application, accelerate to 64.4 km/h (40 mph) and maintain that speed until making the next brake application at a point 1.6 km (1 mi.) from the initial point of the previous brake application. If the vehicle cannot attain a speed of 64.4 km/h (40 mph) in 1.6 km (1 mi.), continue to accelerate until the vehicle reaches 64.4 km/h (40 mph) or until the vehicle has traveled 2.4 km (1.5 mi.) from the initial point of the previous brake application, whichever occurs first. The brakes shall be adjusted three times during the burnish procedure, in accordance with the manufacturer's recommendations, after 125, 250, and 375 snubs.

S7.4.2.2 Post-burnish brake adjustment. After burnishing, adjust the brakes in accordance with the manufacturer's published recommendations.

S7.5 (a) Stability and control during braking (vehicles with a GVWR greater than 4 536 kg [10,000 lb.])

Make four stops in the lightly-loaded ~~mass~~ ~~weight~~ condition specified in S5.1.7. Use a full brake application for the duration of the stop, with the clutch pedal depressed or the transmission ~~selector~~ control in the neutral position, for the duration of each stop.

S7.5 (b) Service brake system — Second effectiveness test

For vehicles with a GVWR of 4 536 kg (10,000 lb.) or less, or any school bus, make six stops from 48.3 km/h (30 mph). Then, for any vehicle, make six stops from 96.6 km/h (60 mph). Then, for a vehicle with a GVWR of 4 536 kg (10,000 lb.) or less, make four stops from 128.8 km/h (80 mph) if the speed attainable in 3.2 km (2 mi.) is not less than 135.2 km/h (84 mph).

S7.6 First reburnish

Repeat S7.4, except make 35 burnish stops or snubs. In the case of vehicles burnished in accordance with S7.4.2.1(a) of this section, reburnish the vehicle by making 35 snubs from 96.6 to 32.2 km/h (60 to 20 mph), but if the hottest brake temperature reaches 260°C ± 27.8°C (500°F ± 50°F), make the remainder of the brake applications from the highest snub condition listed in Table IV that will maintain the hottest brake temperature at 260°C ± 27.8°C (500°F ± 50°F). If, at a snub condition of 64.4 to 32.2 km/h (40 to 20 mph), the temperature of the hottest brake exceeds 287.8°C (550°F), make the remainder of the 35 brake applications from the snub condition without regard to brake temperature.

S7.7 Parking brake test

The parking brake tests for any vehicle on different grades, in different directions, and for different loads may be conducted in any order. The force required for actuation of a hand-operated brake system shall be measured at the center of the hand grip area or at a distance of 38 mm (1.5 in.) from the end of the actuation lever, as illustrated in Figure 2.

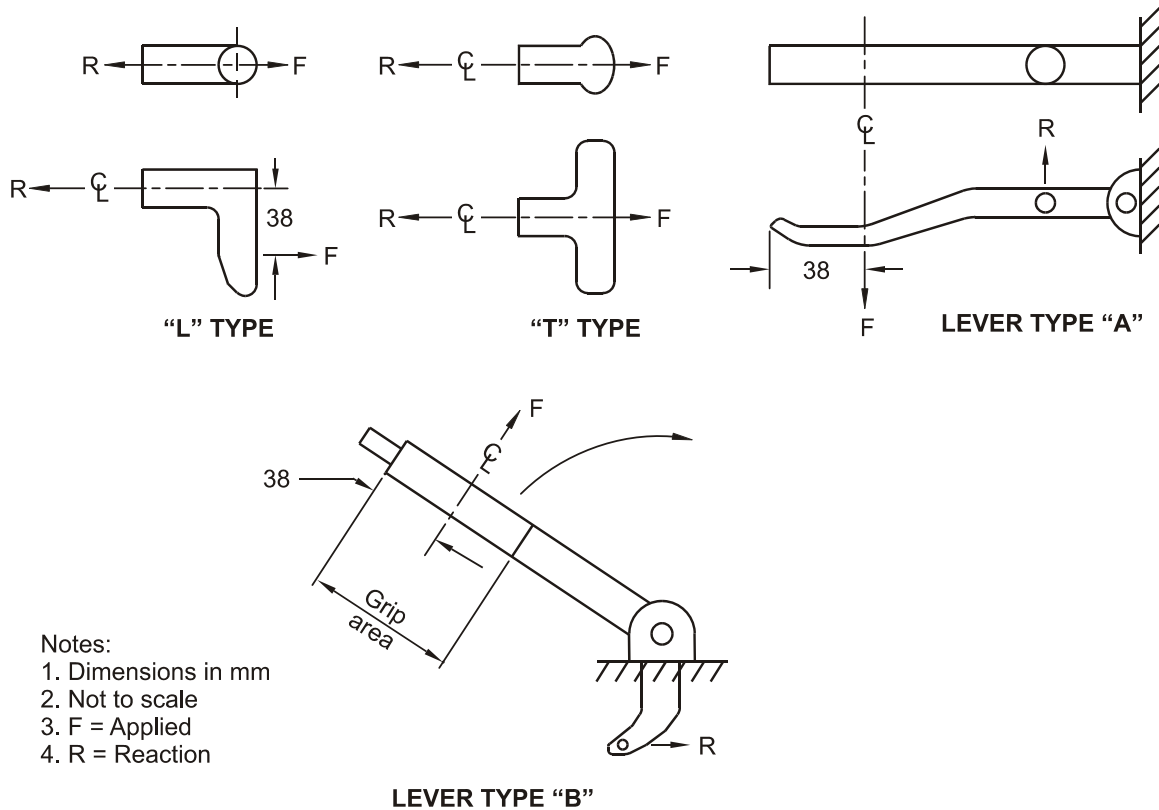

Figure 2 — Location for Measuring Brake Application Force on Hand Brakes

S7.7.1 Test procedure for the requirements of S5.2.1 and S5.2.3

S7.7.1.1 Condition the parking brake friction elements so that the temperature at the beginning of the test is at any level not more than 65.6°C (150°F) (when the temperature of components on both ends of an axle are averaged).

S7.7.1.2 Drive the vehicle, loaded to GVWR, onto the specified grade with the longitudinal axis of the vehicle in the direction of the slope of the grade, stop the vehicle and hold it stationary by application of the service brake control, and place the transmission in "neutral".

S7.7.1.3 With the vehicle held stationary by means of the service brake control, apply the parking brake by a single application of the force specified in (a), (b), or (c) of this paragraph, except that a series of applications to achieve the specified force may be made in the case of a parking brake system design that does not allow the application of the specified force in a single application:

- (a) In the case of a passenger car or other vehicle with a GVWR of $4\,536\text{ kg}$ ($10,000\text{ lb.}$) or less, not more than 556 N (125 lb.) for a foot-operated system, and not more than 400.3 N (90 lb.) for a hand-operated system; and

- (b) In the case of a vehicle with a GVWR greater than 4 536 kg (10,000 lb.), not more than 667.2 N (150 lb.) for a foot-operated system, and not more than 556 N (125 lb.) for a hand-operated system.
- (c) For a vehicle using an electrically activated parking brake, apply the parking brake by activating the parking brake control.

S7.7.1.4 Following the application of the parking brake in accordance with S7.7.1.3, release all force on the service brake control and commence the measurement of time if the vehicle remains stationary. If the vehicle does not remain stationary, reapplication of the service brake to hold the vehicle stationary, with reapplication of a force to the parking brake control at the level specified in S7.7.1.3 (a) or (b), as appropriate for the vehicle being tested (without release of the ratcheting or other holding mechanism of the parking brake), may be used twice to attain a stationary position.

S7.7.1.5 Following observation of the vehicle in a stationary condition for the specified time in one direction, repeat the same test procedure with the vehicle orientation in the opposite direction on the specified grade.

S7.7.1.6 Check the operation of the parking brake application indicator required by S5.3.1(d).

S7.7.2 Test procedure for the requirements of S5.2.2

- (a) Check that the transmission must be placed in the “park” position to release the key;
- (b) Test as in S7.7.1, except in addition place the transmission control to engage the parking mechanism; and
- (c) Test as in S7.7.1, except on a 20 percent grade, with the parking mechanism not engaged.

S7.7.3 Lightly loaded vehicle. Repeat S7.7.1 or S7.7.2, as applicable, except with the vehicle at lightly loaded vehicle mass weight, or at the manufacturer's option, for a vehicle with GVWR greater than 4 536 kg (10,000 lb.), at lightly loaded vehicle mass weight plus not more than an additional 453.6 kg (1,000 lb.) for a roll bar structure on the vehicle.

S7.7.4 Non-service brake type parking brake systems. For vehicles with parking brake systems not utilizing the service brake friction elements, burnish the friction elements of such systems prior to parking brake tests according to the manufacturer's published recommendations as furnished to the purchaser. If no recommendations are furnished, run the vehicle in an unburnished condition.

S7.8 Service brake system — Lightly loaded vehicle (third effectiveness) test

Make six stops from 96.6 km/h (60 mph) with the vehicle at lightly loaded vehicle mass weight, or at the manufacturer's option, for a vehicle with GVWR greater than 4 536 kg (10,000 lb.), at lightly loaded vehicle mass weight plus not more than an

additional 453.6 kg (1,000 lb.) for a roll bar structure on the vehicle. (This test is not applicable to a vehicle which has a GVWR of not less than 3 500 kg [7,716 lb.] and not greater than 4 536 kg [10,000 lb.] and is not a school bus.)

S7.9 Service brake system test — Partial failure

S7.9.1 With the vehicle at lightly loaded vehicle mass weight, or at the manufacturer's option, for a vehicle with a GVWR greater than 4 536 kg (10,000 lb.), at lightly loaded vehicle mass weight plus not more than an additional 453.6 kg (1,000 lb.) for a roll bar structure on the vehicle, alter the service brake system to produce any one rupture or leakage type of failure, other than a structural failure of a housing that is common to two or more subsystems. Determine the control force, pressure level, or fluid level (as appropriate for the indicator being tested) necessary to activate the brake system indicator lamp. Make four stops if the vehicle is equipped with a split service brake system, or 10 stops if the vehicle is not so equipped, each from 96.6 km/h (60 mph), by a continuous application of the service brake control. Restore the service brake system to normal at completion of this test.

S7.9.2 Repeat S7.9.1 for each of the other subsystems.

S7.9.3 Repeat S7.9.1 and S7.9.2 with the vehicle at GVWR. Restore the service brake system to normal on completion of this test.

S7.9.4 (For vehicles with antilock and/or variable brake proportioning systems). With the vehicle at GVWR, disconnect the functional power source or otherwise render the antilock system inoperative. Disconnect the variable brake proportioning system. Make four stops, each from 96.6 km/h (60 mph). If more than one antilock or variable brake proportioning subsystem is provided, disconnect or render one subsystem inoperative and run as above. Restore the system to normal on completion of this test. Repeat for each subsystem provided. Determine whether the brake system indicator lamp is activated when the electrical power source to the antilock or variable proportioning unit is disconnected.

S7.9.5 For a vehicle in which the brake signal is transmitted electrically between the brake pedal and some or all of the foundation brakes, regardless of the means of actuation of the foundation brakes, the tests in S7.9.1 through S7.9.3 of this TSD standard are conducted by inducing any single failure in any circuit that electrically transmits the brake signal, and with all other systems intact. Determine whether the brake system indicator lamp is activated when the failure is induced.

S7.9.6 For an EV with RBS that is part of the service brake system, the tests specified in S7.9.1 through S7.9.3 are conducted with the RBS disconnected and all other systems intact. Determine whether the brake system indicator lamp is activated when the RBS is disconnected.

S7.10 Service brake system — Inoperative brake power unit or brake power assist unit test

(For vehicles equipped with a brake power unit or brake power assist unit)

S7.10.1 Regular procedure. (This test need not be run if the option in S7.10.2 is selected.) On vehicles with brake power assist units, render the brake power assist unit inoperative, or one of the brake power assist unit subsystems if two or more subsystems are provided, by disconnecting the relevant power supply. Exhaust any residual brake power reserve capability in the disconnected system. On vehicles with brake power units, disconnect the primary source of power. Make four stops, each from 96.6 km/h (60 mph) by a continuous application of the service brake control. Restore the system to normal on completion of this test. For vehicles equipped with more than one brake power unit or brake power assist unit, conduct tests of each in turn.

S7.10.2 Optional Procedures. On vehicles with brake power assist units, the unit is charged to maximum prior to the start of the test. (The engine may be run up in speed, then the throttle closed quickly to attain maximum charge on vacuum assist units.) Brake power units shall also be charged to maximum accumulator pressure prior to the start of the test. No recharging is allowed after the start of the test.

- (a) (For vehicles with brake power assist units.) Disconnect the primary source of power. Make six stops each from 96.6 km/h (60 mph) to achieve the average deceleration for each stop specified in Table III. Apply the brake control as quickly as possible. Maintain control force until the vehicle has stopped. At the completion of the stops specified above, deplete the system of any residual brake power reserve capability. Make one stop from 96.6 km/h (60 mph) at an average deceleration not lower than 2.13 m/s² (7 fpsps) for passenger cars (equivalent stopping distance 168.9 m [554 ft.]), or 1.83 m/s² (6 fpsps) for vehicles other than passenger cars (equivalent stopping distance 197 m [646 ft.]) and determine whether the control force exceeds 667.2 N (150 lb.).
- (b) (For vehicles with brake power units with accumulator-type systems.) Test as in S7.10.2(a), except make 10 stops instead of 6 and, at the completion of the 10 stops, deplete the failed element of the brake power unit of any residual brake power reserve capability before making the final stop.
- (c) (For vehicles with brake power assist or brake power units with backup systems.) If the brake power or brake power assist unit operates in conjunction with a backup system and the backup system is activated automatically in a power failure, the backup system is operative during this test. Disconnect the primary source of power of one subsystem. Make 15 stops, each from 96.6 km/h (60 mph), with the backup system activated for the failed subsystem, to achieve an average deceleration of 3.66 m/s² (12 fpsps) for each stop.
- (d) Restore systems to normal on completion of these tests. For vehicles equipped with more than one brake power assist or brake power unit, conduct tests of each in turn.

S7.10.3 Electric brakes

- (a) For vehicles with electrically actuated service brakes, the tests in S7.10.1 or S7.10.2 are conducted with any single electrical failure in the electric brake system instead of the brake power or brake power assist systems, and all other systems intact.
- (b) For EVs with RBS that is part of the service brake system, the tests in S7.10.1 or S7.10.2 are conducted with the RBS discontinued and all other systems intact.

S7.11 Service brake system — First fade and recovery test

S7.11.1 Baseline check stops or snubs

S7.11.1.1 *Vehicles with a GVWR of 4 536 kg (10,000 lb.) or less.* Make three stops from 48.3 km/h (30 mph) at 3.05 m/s² (10 fpsps) for each stop. Control force readings may be terminated when the vehicle speed falls to 8.05 km/h (5 mph). Average the maximum brake control force required for the three stops.

S7.11.1.2 *Vehicles with a GVWR greater than 4 536 kg (10,000 lb.).* With the transmission in “neutral” (or declutched), make three snubs from 64.4 to 32.2 km/h (40 to 20 mph) at 3.05 m/s² (10 fpsps) for each snub. Average the maximum brake control force required for the three snubs.

S7.11.2 Fade stops or snubs

S7.11.2.1 *Vehicles with a GVWR of 4 536 kg (10,000 lb.) or less.* Make 5 stops from 96.6 km/h (60 mph) at 4.57 m/s² (15 fpsps), followed by 5 stops at the maximum attainable deceleration between 1.52 and 4.57 m/s² (5 and 15 fpsps) for each stop. Establish an initial brake temperature before the first brake application of 54.4°C to 65.6°C (130°F to 150°F). Initial brake temperatures before brake applications for subsequent stops are those occurring at the distance intervals. Attain the required deceleration within 1 second and, as a minimum, maintain it for the remainder of the stopping time. Control force readings may be terminated when the vehicle speed falls to 8.05 km/h (5 mph). Leave an interval of 0.64 km (0.4 mi.) between the start of brake applications. Accelerate immediately to the initial test speed after each stop. Drive 1.6 km (1 mi.) at 48.3 km/h (30 mph) after the last fade stop, and immediately follow the recovery procedure specified in S7.11.3.1.

S7.11.2.2 *Vehicles with a GVWR greater than 4 536 kg (10,000 lb.).* With the transmission in “neutral” (or declutched), make 10 snubs from 64.4 to 32.2 km/h (40 to 20 mph) at 3.05 m/s² (10 fpsps) for each snub. Establish an initial brake temperature before the first brake application of 54.4°C to 65.6°C (130°F to 150°F). Initial brake temperatures before brake application for subsequent snubs are those occurring in the time intervals specified below. Attain the required deceleration within 1 second and maintain it for the remainder of the snubbing time. Leave an interval of 30 seconds between snubs (start of brake application to start of brake application). Accelerate immediately to the initial test speed after each snub. Drive for 2.4 km (1.5 mi.) at

64.4 km/h (40 mph) after the last snub and immediately follow the recovery procedure specified in S7.11.3.2.

S7.11.3 Recovery stops or snubs

S7.11.3.1 *Vehicles with a GVWR of 4 536 kg (10,000 lb.) or less.* Make five stops from 48.3 km/h (30 mph) at 3.05 m/s² (10 fpsps) for each stop. Control force readings may be terminated when the vehicle speed falls to 8.05 km/h (5 mph). Allow a braking distance interval of 1.6 km (1 mi.). Immediately after each stop, accelerate at maximum rate to 48.3 km/h (30 mph) and maintain that speed until making the next stop. Record the maximum control force for each stop.

S7.11.3.2 *Vehicles with a GVWR greater than 4 536 kg (10,000 lb.).* With the transmission in “neutral” (or declutched), make five snubs from 64.4 to 32.2 km/h (40 to 20 mph) at 3.05 m/s² (10 fpsps) for each snub. After each snub, accelerate at maximum rate to 64.4 km/h (40 mph) and maintain that speed until making the next brake application at a point 2.4 km (1.5 mi.) from the point of the previous brake application. Record the maximum control force for each snub.

S7.12 Service brake system — Second reburnish

Repeat S7.6.

S7.13 Service brake system — Second fade and recovery test

Repeat S7.11, except in S7.11.2 run 15 fade stops or 20 snubs instead of 10.

S7.14 Third reburnish

Repeat S7.6.

S7.15 Service brake system — Fourth effectiveness test

Repeat S7.5. Then (for passenger cars) make four stops from either 153 km/h (95 mph) if the speed attainable in 3.2 km (2 mi.) is from 159.3 km/h (99 mph) to (but not including) 167.4 km/h (104 mph), or 161 km/h (100 mph) if the speed attainable in 3.2 km (2 mi.) is 167.4 km/h (104 mph) or greater.

S7.16 Service brake system — Water recovery test

S7.16.1 Baseline check stop. Make three stops from 48.3 km/h (30 mph) at 3.05 m/s² (10 fpsps) for each stop. Control force readings may be terminated when the vehicle speed falls to 8.05 km/h (5 mph). Average the maximum brake control force required for the three stops.

S7.16.2 Wet brake recovery stops. With the brakes fully released at all times, drive the vehicle for 2 minutes at a speed of 8.05 km/h (5 mph), in any combination of forward and reverse directions, through a trough having a water depth of 152.4 mm (6 in.). After leaving the trough, immediately accelerate at a maximum rate to 48.3 km/h (30 mph)

without a brake application. Immediately upon reaching that speed make five stops, each from 48.3 km/h (30 mph) at 3.05 m/s² (10 fpsps) for each stop. After each stop (except the last), accelerate the vehicle immediately at a maximum rate to a speed of 48.3 km/h (30 mph) and begin the next stop.

S7.17 Spike stops

Make 10 successive spike stops from 48.3 km/h (30 mph) with the transmission in “neutral”, with no reverse stops. Make spike stops by applying a control force of 889.6 N (200 lb.) while recording control force versus time. Maintain control force until the vehicle has stopped. On completion of 10 spike stops, make six effectiveness stops from 96.6 km/h (60 mph).

S7.18 Final inspection

Inspect:

- (a) The service brake system for detachment or fracture of any components, such as brake springs and brake shoes or disc pad facings.
- (b) The friction surface of the brake, the master cylinder or the brake power unit reservoir cover and seal and filler openings, for leakage of brake fluid or lubricant.
- (c) The master cylinder or brake power unit reservoir for compliance with the volume and labeling requirements of S5.4.2 and S5.4.3. In determining the fully applied worn condition, assume that the lining is worn to:
 - (1) the rivet or bolt heads on riveted or bolted linings, or
 - (2) within 0.8 mm (1/32 in.) of the shoe or pad mounting surface on bonded linings, or
 - (3) the limit recommended by the manufacturer, whichever is larger relative to the total possible shoe or pad movement. Drums or rotors are assumed to be at nominal design drum diameter or rotor thickness. Linings are assumed adjusted for normal operating clearance in the released position.
- (d) The brake system indicator light(s), for compliance with operation in various key positions and lens color, labeling, and location requirements, in accordance with S5.3.

S7.19 Moving barrier test

(Only for vehicles that have been tested according to S7.7.2) Load the vehicle to GVWR, release the parking brake, and place the transmission ~~selector~~ control to engage the parking mechanism. With a moving barrier as described in paragraph 4.3 of SAE Recommended Practice J972, *Moving Barrier Collision Tests*, November 1966 (revised May 2000), impact the vehicle from the front at 4.02 km/h (2.5 mph). [FOUR SENTENCES HAVE BEEN DELETED.] Keep the longitudinal axis of the barrier parallel with the longitudinal axis of the vehicle. Repeat the test, impacting the vehicle from the rear.

Note: The vehicle used for this test need not be the same vehicle that has been used for the braking tests.

Table I — Brake Test Procedure Sequence and Requirements

Number and Sequence	Test Load		Test Procedure	Requirements
	Light	GVWR		
1. Instrumentation check			S7.2	
2. First (preburnish) effectiveness test		X	S7.3	S5.1.1.1
3. Burnish procedure		X	S7.4	
4. Second effectiveness test		X	S7.5(b)	S5.1.1.2
5. First reburnish		X	S7.6	
6. Parking brake	X	X	S7.7	S5.2
7. Stability and control during braking (braking-in-a-curve test)	X		S7.5(a)	S5.1.7
8. Third effectiveness (lightly loaded vehicle)	X		S7.8	S5.1.1.3
9. Partial failure	X	X	S7.9	S5.1.2
10. Inoperative brake power or power assist units		X	S7.10	S5.1.3
11. First fade and recovery		X	S7.11	S5.1.4
12. Second reburnish		X	S7.12	
13. Second fade and recovery		X	S7.13	S5.1.4
14. Third reburnish		X	S7.14	
15. Fourth effectiveness		X	S7.15	S5.1.1.4
16. Water recovery		X	S7.16	S5.1.5
17. Spike stops		X	S7.17	S5.1.6
18. Final inspection			S7.18	S5.6
19. Moving barrier test		X	S7.19	S5.2.2.3

Table II — Stopping Distances

Stopping Distance in <u>Metres</u> (feet) for the Tests Indicated								
Vehicle test speed, km/h (mph)	COLUMN I First (preburnished), fourth effectiveness, and spike effectiveness check				COLUMN II Second effectiveness test			
	(a)	(b)	(c)	(d)	(a)	(b) and (c)	(d)	(e)
48.3 (30)	¹ 17.38 (57)	^{1,2} 19.82 (65)	^{1,2} 21.04* (69)	NA NA	NA NA	NA NA	NA NA	NA NA
48.3 (30)	NA NA	NA NA	^{1,2} 19.82 [§] (65)	NA NA	NA NA	NA NA	NA NA	NA NA
48.3 (30)	NA NA	NA NA	¹ 21.95 (72)	26.83 (88)	¹ 16.46 (54)	¹ 17.38 (57)	23.77 (78)	^{1,2} 21.34 (70)
56.4 (35)	22.56 (74)	25.30 (83)	27.74 (91)	40.24 (132)	21.34 (70)	22.56 (74)	32.31 (106)	29.27 (96)
64.4 (40)	29.27 (96)	32.93 (108)	36.28 (119)	52.74 (173)	27.74 (91)	29.27 (96)	42.06 (138)	37.80 (124)
72.3 (45)	36.89 (121)	41.77 (137)	45.73 (150)	66.46 (218)	35.06 (115)	36.89 (121)	53.34 (175)	48.16 (158)
80.5 (50)	45.73 (150)	51.52 (169)	56.40 (185)	80.49 (264)	43.29 (142)	45.73 (150)	65.85 (216)	59.44 (195)
88.6 (55)	55.18 (181)	62.20 (204)	68.29 (224)	99.39 (326)	52.44 (172)	55.18 (181)	79.55 (261)	71.93 (236)
96.6 (60)	¹ 65.85 (216)	¹ 73.78 (242)	¹ 81.40 (267)	118.29 (388)	¹ 62.20 (204)	¹ 65.85 (216)	¹ 94.49 (310)	¹ 85.34 (280)
128.8 (80)	¹ 123.48 (405)	¹ 139.94 (459)	¹ 155.49 (510)	NA NA	¹ 116.7 7 (383)	NA NA	NA NA	NA NA
153 (95)	¹ 185.06 (607)	NA NA	NA NA	NA NA	NA NA	NA NA	NA NA	NA NA
161 (100)	¹ 205.18 (673)	NA NA	NA NA	NA NA	NA NA	NA NA	NA NA	NA NA

- ¹: Distances for specified tests
²: Applicable to school buses only
*: First (preburnished) test
[§]: Fourth and spike effectiveness tests
NA: Not applicable

- Note:** (a) Passenger cars
(b) Vehicles other than passenger cars with a GVWR less than 3 629 kg (8,000 lb.)
(c) Vehicles with a GVWR not less than 3 629 kg (8,000 lbs.) and not more than 4 536 kg (10,000 lb.)
(d) Vehicles with a GVWR greater than 4 536 kg (10,000 lb.)
(e) Buses, including school buses, with a GVWR greater than 4 536 kg (10,000 lb.)

Table II — Stopping Distances (Cont'd)

Stopping Distance in <u>Metres</u> (feet) for the Tests Indicated								
Vehicle test speed, <u>Km/h</u> (mph)	COLUMN III Third (lightly loaded vehicle) effectiveness test					COLUMN IV Inoperative brake power or power assist unit test; partial failure test		
	(a)	(b)	(c)	(d)	(e)	(a)	(b) and (c)	(d) and (e)
48.3 (30)	15.55 (51)	17.38 (57)	19.82 (65)	25.60 (84)	21.34 (70)	34.76 (114)	39.63 (130)	51.83 (170)
56.4 (35)	20.43 (67)	22.56 (74)	25.30 (83)	34.75 (114)	29.27 (96)	47.26 (155)	53.66 (176)	68.60 (225)
64.4 (40)	26.52 (87)	29.27 (96)	32.93 (108)	45.42 (149)	37.80 (124)	61.59 (202)	69.82 (229)	87.80 (288)
72.3 (45)	33.54 (110)	36.89 (121)	41.77 (137)	57.61 (189)	48.16 (158)	78.35 (257)	88.72 (291)	109.15 (358)
80.5 (50)	41.16 (135)	45.73 (150)	51.52 (169)	71.02 (233)	59.44 (195)	96.65 (317)	109.45 (359)	132.62 (435)
88.6 (55)	49.70 (163)	55.18 (181)	62.20 (204)	85.65 (281)	71.93 (236)	116.77 (383)	132.01 (433)	161.59 (530)
96.6 (60)	¹ 59.15 (194)	¹ 65.85 (216)	¹ 73.78 (242)	¹ 102.11 (335)	¹ 85.34 (280)	¹ 139.02 (456)	¹ 157.62 (517)	¹ 186.89 (613)
128.8 (80)	NA	NA	NA	NA	NA	NA	NA	NA
153 (95)	NA	NA	NA	NA	NA	NA	NA	NA
161 (100)	NA	NA	NA	NA	NA	NA	NA	NA

¹ Distances for specified tests

NA: Not applicable

Note: (a) Passenger cars

(b) Vehicles other than passenger cars with a GVWR less than 3 629 kg (8,000 lb.)

(c) Vehicles with a GVWR not less than 3 629 kg (8,000 lbs.) and not more than 4 536 kg (10,000 lb.)

(d) Vehicles with a GVWR greater than 4 536 kg (10,000 lb.)

(e) Buses, including school buses, with a GVWR greater than 4 536 kg (10,000 lb.)

Table III — Inoperative Brake Power Assist and Brake Power Units

Average deceleration, m/s^2 (fpsps)				
Stop No.	Column I — Brake power assist		Column II — Brake power unit	
	(a)	(b) and (c)	(a)	(b) and (c)
1	4.88 (16.0)	4.27 (14.0)	4.88 (16.0)	3.96 (13.0)
2	3.66 (12.0)	3.66 (12.0)	3.96 (13.0)	3.35 (11.0)
3	3.05 (10.0)	3.05 (10.0)	3.66 (12.0)	3.05 (10.0)
4	2.74 (9.0)	2.59 (8.5)	3.35 (11.0)	2.90 (9.5)
5	2.44 (8.0)	2.29 (7.5)	3.05 (10.0)	2.74 (9.0)
6	2.29 (7.5)	2.04 (6.7)	2.90 (9.5)	2.59 (8.5)
7	*2.13 (7.0)	*1.83 (6.0)	2.74 (9.0)	2.44 (8.0)
8	NA	NA	2.59 (8.5)	2.29 (7.5)
9	NA	NA	2.44 (8.0)	2.13 (7.0)
10	NA	NA	2.29 (7.5)	1.98 (6.5)
11	NA	NA	*2.13 (7.0)	*1.83 (6.0)

Equivalent stopping distance, <u>metres</u> (feet)				
Stop No.	Column III — Brake power assist		Column IV — Brake power unit	
	(a)	(b) and (c)	(a)	(b) and (c)
1	73.8 (242)	87.5 (277)	73.8 (242)	90.6 (298)
2	98.5 (323)	98.5 (323)	90.8 (298)	107.3 (352)
3	118.3 (388)	118.3 (388)	98.5 (323)	118.3 (388)
4	131.4 (431)	139.0 (456)	107.3 (352)	124.7 (409)
5	147.6 (484)	157.6 (517)	118.3 (388)	131.4 (431)
6	157.6 (517)	176.8 (580)	124.7 (409)	139.0 (456)
7	168.9 (554)	196.6 (646)	131.4 (431)	147.6 (484)
8	NA	NA	139.0 (456)	157.6 (517)
9	NA	NA	147.6 (484)	168.9 (554)
10	NA	NA	157.6 (517)	181.7 (596)
11	NA	NA	168.9 (554)	196.6 (646)

*: Depleted

NA: Not applicable

Note: (a) Passenger cars
 (b) Vehicles other than passenger cars with a GVWR of 4 536 kg (10,000 lb.) or less
 (c) Vehicles with a GVWR greater than 4 536 kg (10,000 lbs.)

Table IV

Series	Snubs	Snub conditions, highest speed indicated in <u>km/h</u> (mph)
1	175	<u>64.4 - 32.2</u> (40 - 20)
2	25	<u>72.5 - 32.2</u> (45 - 20)
3	25	<u>80.5 - 32.2</u> (50 - 20)
4	25	<u>88.6 - 32.2</u> (55 - 20)
5	250	<u>96.6 - 32.2</u> (60 - 20)